

TMC8462A Datasheet

Document Revision V1.10 • 2022-Aug-29

The TMC8462A is a complete EtherCAT® Slave Controller optimized for real time. It comprises all blocks required for an EtherCAT slave including two 100-MBit PHYs, a dual switch regulator power supply and 24V capable high voltage I/Os for industrial environments. Timer, watchdog, PWM and SPI/IIC master units allow for enhanced capabilities either in device emulation mode or in combination with an external CPU.

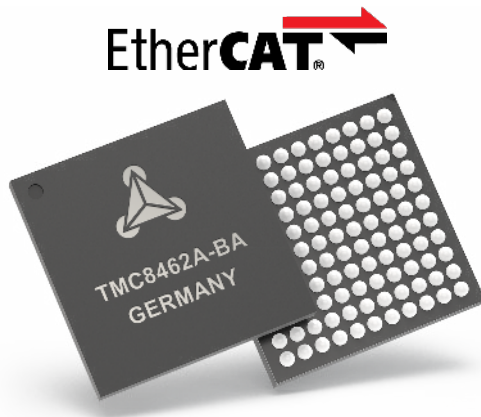

Features

- Standard compliant EtherCAT® Slave Controller
- 2x Integrated 100-MBit Ethernet PHY
- SPI Process Data Interface (PDI)
- Auxiliary IO Block with 24 configurable Multi-Function I/Os
- 4.75V...35V Supply Voltage range
- 2x Integrated 3.3V and 5V-24V buck regulators
- 8 High Voltage I/Os (up to 35V, 100mA)
- -40°C to +85°C Temperature Range
- 9x9mm 121pin BGA package

Applications

- Motor Drives
- Industrial Automation
- Communication Modules
- Industry 4.0
- Sensors & Encoders
- Robotics
- Building Automation
- Real-time control
- Connected Motion

Simplified Block Diagram

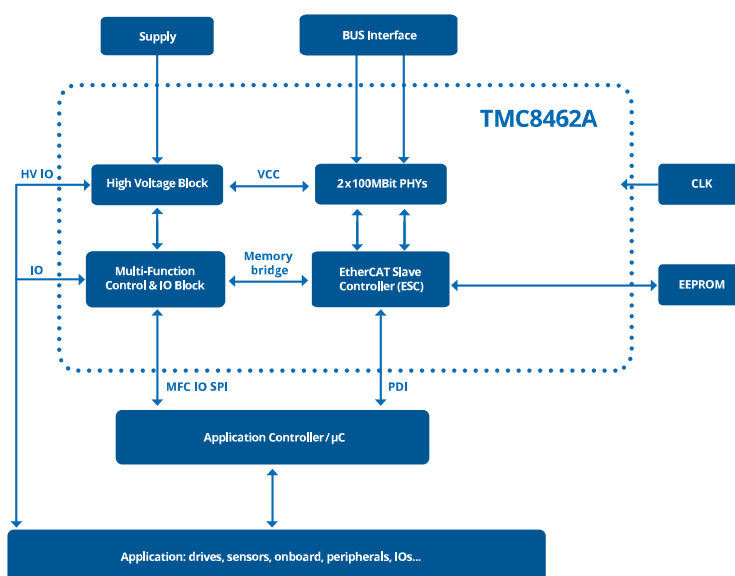

Contents

1	Product Features	5
2	Order Codes	6
3	Principles of Operation / Key Concepts	7
3.1	General Device Architecture	7
3.2	EtherCAT Slave Controller	8
3.3	Multi-Function and Control IO Block	8
3.4	Analog and High Voltage Block	9
3.5	Interfaces	10
3.6	Software- and Tool-Support	10
4	Device Pin Definitions	15
4.1	Pinout and Pin Coordinates of TMC8462A-BA	15
4.2	Signal Descriptions	15
5	Device Usage and Handling	23
5.1	Process Data Interface	23
5.1.1	SPI protocol description	24
5.1.2	Timing example	26
5.2	MFC IO Control Interface	27
5.2.1	SPI Protocol description	27
5.2.2	Timing example	28
5.2.3	Sharing Bus Lines with the PDI SPI	28
5.3	Ethernet Physical Layer Connection	30
5.4	External Circuitry and Applications Examples	31
5.4.1	Device Reset	31
5.4.2	Supply Filtering for PLL Supply	31
5.4.3	PHY Power Regulator Filtering	32
5.4.4	External Circuit for Fixed Switching Regulator 0	33
5.4.5	External Circuit for Adjustable Switching Regulator 1	34
5.4.6	Minimum External Supply Circuit for Single 3.3V Supply	35
5.4.7	Minimum External Supply Circuit for Single 5V Supply	36
5.4.8	Minimum External Supply Circuit for Single Supply >5V	37
5.4.9	Typical Power Supply Chain Using Both Buck Converters	38
5.4.10	Status LED Circuit	38
5.4.11	SII EEPROM Circuit	38
5.4.12	Considerations on PHY to PHY Connection	39
6	EtherCAT Slave Controller Description	40
6.1	General EtherCAT Information	40
6.2	Overview of Available Chip Features	41
6.3	EtherCAT Register Overview	43
6.4	EtherCAT Register Set	49
6.4.1	ESC Information	49
6.4.2	Station Address	53
6.4.3	Write Protection	54
6.4.4	Data Link Layer	56
6.4.5	Application Layer	61
6.4.6	PDI	64
6.4.7	Interrupts	68
6.4.8	Error Counters	71
6.4.9	Watchdogs	74

6.4.10	SII EEPROM Interface	77
6.4.11	ESC Parameter RAM	81
6.4.12	MII Management Interface	82
6.4.13	FMMUs	86
6.4.14	SyncManagers	89
6.4.15	Distributed Clocks Receive Times	93
6.4.16	Distributed Clocks Time Loop Control Unit	94
6.4.17	Distributed Clocks Cyclic Unit Control	98
6.4.18	Distributed Clocks SYNC Out Unit	99
6.4.19	Distributed Clocks LATCH In Unit	103
6.4.20	Distributed Clocks SyncManager Event Times	107
6.4.21	ESC Specific	108
6.4.22	Process Data RAM	109
7	MFC IO Block Description	110
7.1	General Information	110
7.2	MFC IO Register Overview	112
7.3	MFC IO Register Set	115
7.3.1	Incremental Encoder Interface	115
7.3.2	SPI Master Interface	118
7.3.3	I2C Master Interface	120
7.3.4	Step and Direction Signal Generator	122
7.3.5	PWM Unit	128
7.3.6	General Purpose I/Os	132
7.3.7	DAC Unit	133
7.3.8	IRQ Control Block	134
7.3.9	Watchdog	136
7.3.10	High Voltage Status and General Control	139
7.3.11	Application Layer Control	143
7.4	SII EEPROM MFC IO Block Parameter Map	144
7.5	SII EEPROM MFC IO Crossbar Mapping	148
7.6	SII EEPROM MFC IO High Voltage IO (HVIO) Configuration	152
7.7	SII EEPROM MFC IO Switching Regulator Configuration	153
7.8	SII EEPROM MFC IO Memory Block Mapping	155
7.8.1	Sync Manager Configuration and Memory Blocks	156
7.9	SII EEPROM MFC IO Register Configuration	157
7.10	MFC IO ESI/XML Configuration Block	159
7.11	MFC IO Incremental Encoder Block	160
7.12	MFC IO SPI Master Block	162
7.12.1	SPI Examples	163
7.13	MFC IO I2C Master Block	167
7.13.1	I2C Example	169
7.14	MFC IO Step and Direction Block	171
7.15	MFC IO PWM Block	174
7.16	MFC IO DAC Block	180
7.17	MFC IO General Purpose IO Block	181
7.18	MFC IO IRQ Block	182
7.19	MFC IO Watchdog Block	183
7.20	MFC IO Emergency Switch Input	187
7.21	MFC IO Analog and High Voltage Block	188
7.21.1	Multi Voltage High Current I/O Lines	188
7.21.2	Switching Regulators	189
7.21.3	Analog Block Status Register	190

8 Electrical Ratings	192
8.1 Absolute Maximum Ratings	192
8.2 Operational Ratings	193
8.3 DC Characteristics and Timing Characteristics	193
8.3.1 High Voltage I/O Block	193
8.3.2 Switching Regulators	194
8.3.3 Digital IOs	195
9 Manufacturing Data	196
9.1 Package Dimensions	196
9.2 Marking	198
10 Abbreviations	199
11 Figures Index	201
12 Tables Index	202
13 Revision History	205
13.1 IC Revision	205
13.2 Document Revision	205

1 Product Features

TMC8462A is an advanced EtherCAT Slave Controller device used for EtherCAT communication. It provides the interface for data exchange between EtherCAT master and the slave's local application controller. In addition, TMC8462A provides complex IO functions paired with high voltage features and integrated 100-MBit Ethernet PHYs.

Advantages:

- Fully standard compliant and proven EtherCAT engine
- Highly integrated EtherCAT Slave Controller solution
- License-free & royalty-free
- High Voltage & robust
- Saves board space & reduces BOM

Major Features:

- EtherCAT Slave Controller with 2 Ethernet ports, 8 FMMU & 8 Sync Managers, Distributed clocks with 64 bit, 16KByte of Process Data Memory, external I2C EEPROM, SPI Process Data Interface (PDI), optional device emulation
- Multi-Function Control and IO block with 24 configurable IO ports for real-time IO functions (GPIOs, PWM, Step/Direction, I2C, SPI, DAC, incremental encoder)
- High voltage IO block with 8 short circuit protected push-/pull or open drain high voltage I/Os for up to 24V and 100mA drive current
- Two integrated 500mA step-down switching voltage regulators with one being fixed at 3.3V and one being programmable between 5V and 24V
- Internal 1.8V linear regulator for core voltage generation
- Two integrated 100-MBit Ethernet PHYs to directly connect to twisted pair copper or back-to-back directly to another PHY
- Simple configuration of EtherCAT Slave Controller and Multi-Function Control and IO block via EEPROM
- Single supply architecture depending on application: 3.3V only or 5V to 35V (5V, 12V, or 24V typical)
- -40°C to +85°C Temperature Range
- Package: 9mm x 9mm BGA package with 121 pins and 0.75mm pitch

2 Order Codes

Order Code	Description	Size
TMC8462A-BA	TMC8462A Advanced EtherCAT® Slave Controller in 121 pin BGA package with 0.75mm pitch	9mm x 9mm
TMC8462A-EVAL	Evaluation Board for TMC8462A-BA, compatible with the modular Landungsbruecke system, RJ45 twisted pair copper interface	79mm x 85mm
TMC8462A-BOB-ETH	Breakout Board (BOB) for TMC8462A-BA, with 0.1" header rows, reference clock source, SII-EEPROM, and RJ45 twisted pair copper transceiver interface	2.0" x 1.5"

Table 1: TMC8462A order codes

Trademark and Patents



EtherCAT® is a registered trademark and patented technology, licensed by Beckhoff Automation GmbH, Germany.

3 Principles of Operation / Key Concepts

TMC8462A is a highly integrated ASIC providing the interface between the Ethernet-based EtherCAT real-time field bus and the local application. Its extended digital and high voltage feature set provides additional functions to the EtherCAT slave.

3.1 General Device Architecture

Figure 1 shows the general device architecture and major connections of TMC8462A. The four function blocks EtherCAT Slave Controller, Multi-Function Control and IO, Analog and High Voltage, and Ethernet PHYs are introduced in the following sub-sections.

For operation, a stable 25MHz clock source, an IIC EEPROM, and power supply for IO and high voltage operation are required (if the high voltage features are used). An application controller, which also runs the EtherCAT slave stack, connects to the SPI interfaces. The application and onboard peripherals can be controlled by the application controller or the Multi-Function Control and IO block.

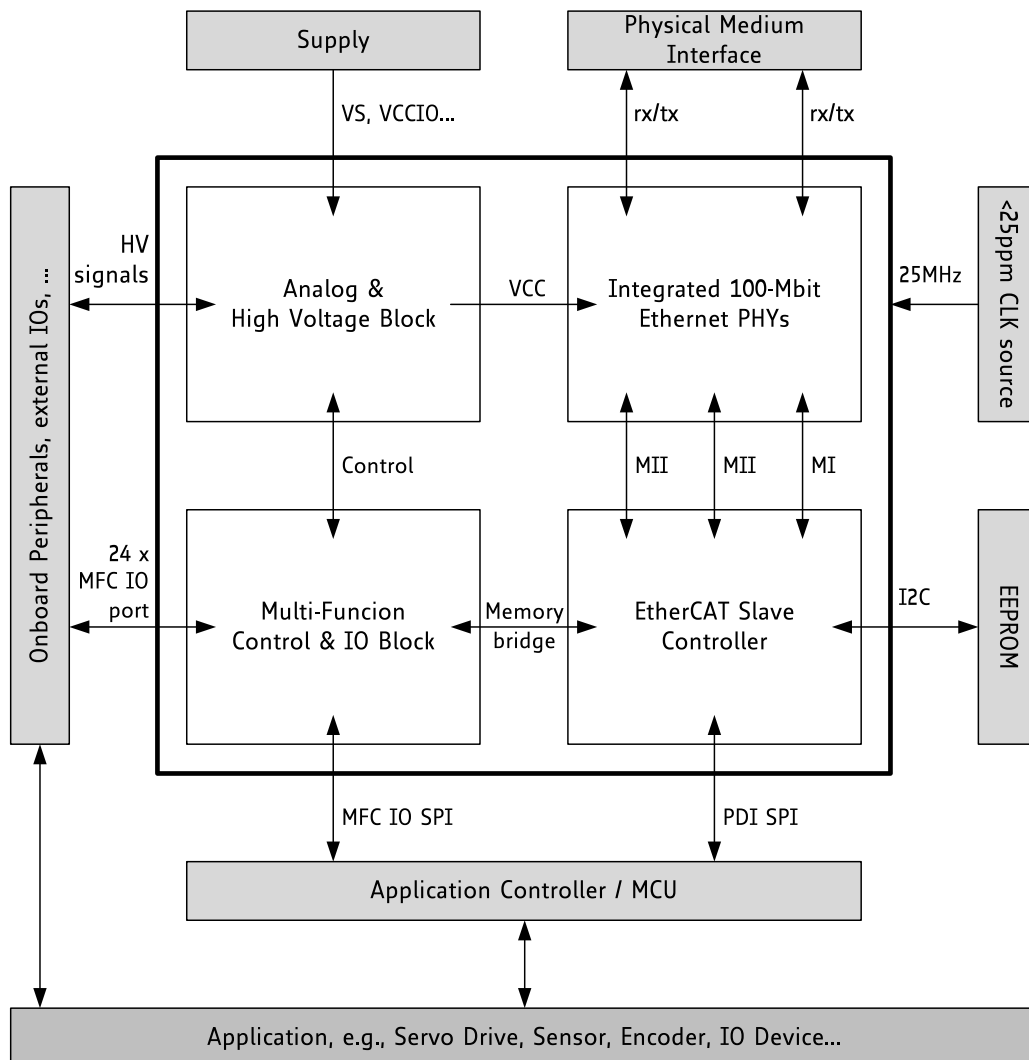

Figure 1: General device architecture

3.2 EtherCAT Slave Controller

TMC8462A contains a standard-conform EtherCAT Slave Controller (ESC) providing real-time EtherCAT MAC layer functionality to EtherCAT slaves. It connects via MII interface to standard Ethernet PHYs and provides a digital control interface to a local application controller while also providing the option for standalone operation.

The ESC part of TMC8462A provides the following EtherCAT-related features. More information is available in Section 6.

- Two internal 100-MBit Ethernet PHYs
- Eight Fieldbus Memory Management Units (FMMU)
- Eight Sync Managers (SM)
- 16 KByte of Process Data RAM (PDRAM)
- 64B bit Distributed Clocks support
- I2C interface for external EEPROM for ESC configuration
- SPI Process Data Interface (PDI) with 30Mbit/s
- Proven EtherCAT State Machine (ESM)
- Device Emulation Mode

3.3 Multi-Function and Control IO Block

In addition to the EtherCAT functionality, the TMC8462A comes with a dedicated function block providing a configurable set of complex real-time IO functionality for smart (embedded) EtherCAT slave systems. This IO functionality is called Multi-Function Control and IO block (MFC IO). Its special focus is on motor and motion control while it is not limited to this application area.

The MFC IO block combines various functional sub blocks that are helpful in an embedded design to reduce complexity, to simplify bill of materials (BOM), and to provide hardware acceleration to compute intensive or time critical tasks. More information is available in Section 7.

Configurable IO Ports The whole MFC IO block provides in total 24 IO ports that can be configured and assigned to any of the available functional units inside the MFC IO block. If not used, each IO port can be tristated.

General Purpose IOs Up to sixteen (16) general purpose IOs are available. Each IO can be configured either as input or as output. For the outputs, a safe state can be configured which is used in case of emergency event.

Incremental Encoder Interface Configurable incremental encoder interface with 32 bit position registers, single-ended or differential inputs, configurable counting constant for different resolutions, configurable polarity and N-signal behavior.

Step/Direction Generator Block The step and direction unit provides up to 3 independent channels. Various configuration options and modes allow for example for continuous or one-shot mode, reading of the internal total step counters, pre-loading the next step frequency to be used at a certain counter value. The step and direction outputs signals can be single-ended or differential.

PWM Block The integrated PWM block provides up to 4 PWM channels. PWM frequency and duty cycle as well as polarities and dead times are configurable. The outputs can be configured for a safe state in case of emergency.

Generic SPI Master Interface The TMC8462A provides a generic SPI master interface to connect to on- or off-board SPI slave peripherals like ADCs, sensors, or motor drivers. The SPI master interface is fully configurable and offers 4 slave select lines.

Generic I2C Master Interface A generic I2C master interface is also available in TMC8462A to connect to I2C slaves. The I2C bus speed is configurable.

Digital DAC A simple digital 16 bit DAC channel is available which requires an external RC circuit for operation.

Safety Functions The following safety functions are available with the TMC8462A

- Configurable watchdog functionality for the MFC IO block to monitor internal and external signals as well as EtherCAT activity. This block is fully configurable.
- A general emergency switch input can be activated. For critical outputs, a safe state can be configured which is used when the emergency switch triggers.
- A common IRQ signal is available at the MFC IO block which can be mapped to various events of the MFC IO block. The IRQ events can be processed by a local application controller.

3.4 Analog and High Voltage Block

TMC8462A has an integrated powerful high voltage sub block that provides analog functions and high voltage support to your EtherCAT slave. The integrated high voltage capabilities allow for BOM reduction and save board space. More information is available in Section 7.21.

High Voltage Ports 8 of the 24 configurable IO ports of the MFC IO block are high voltage IO ports. For pure digital systems operating at 3.3V or 5V these ports can simply be used as standard IO ports. When using a higher supply voltage at the VIOx inputs the high voltage ports can be used at up to 35V (5V, 12V, 24V typical). The 8 high voltage ports are grouped into 3 groups with 2, 3, and 3 ports. Each group can be used a different supply voltage level using VIO1, VIO2, and VIO3 inputs.

Each high voltage port has a short circuit protected push-/pull or open drain output stage with 100mA drive current (ca. 200mA short time) and can be combined with any signal of the MFC IO block functions. The outputs' slope can be controlled. An optional input filter is selectable as well as pull downs or pull ups with 100μA.

The high voltage ports have an over-temperature shutdown.

WARNING

When driving inductive loads a freewheeling diode must be provided to the high voltage I/O pins to prevent from latch-up.

Switching Regulators Two switching regulators (buck regulators) are integrated into TMC8462A – SW0 and SW1. Both are capable of driving up to 500mA.

SW0 generates a fixed 3.3V rail for internal and external logic supply. SW1 is programmable between 3.3V and VS (up to 24V) and can be used for peripheral supply, e.g. to generate a 5V encoder supply.

Each switching regulator comes with a separate over-temperature shutdown.

Single Supply Operation TMC8462A is designed to work with a single external power supply rail. All required supply voltages are generated internally. The required external supply rail depends on the application scenario (between 3.3V and 24V).

3.5 Interfaces

Field Bus Interface TMC8462A contains 2 integrated 100-MBit Ethernet PHYs and directly connects to the field bus using an external transformer circuit. In addition, the PHY interfaces of two TMC8462A devices can also be connected directly to allow back-to-back connection with only low part count and a small circuit. This is useful when extending the EtherCAT bus on the board or to a another slave close by.

ESC Process Data Interface The ESC part can be accessed via the so-called Process Data Interface (PDI). TMC8462A comes with an SPI PDI. Besides the standard SPI bus lines additional control signals belong to the SPI PDI, which are further described in Section 5.1..

MFC IO Control Interface The MFC IO block of TMC8462A can be accessed from EtherCAT master side or from the local application controller. For connection to the local application controller, a second SPI interface – the MFC IO SPI – is provided. The protocol used nearly identical to the SPI PDI interface. Additional information on the MFC IO SPI is given in Section 5.2.

EEPROM Interface The EEPROM interface is intended to be a point-to-point interface between TMC8462A and EEPROM with TMC8462A being the master. If other I2C masters are required to access the I2C bus, TMC8462A must be held in reset state, for example for in-circuit-programming of the EEPROM. During operation, the application controller must tristate its I2C interface. Depending on the EEPROM size the addressing mode must be properly set using the PROM_SIZE configuration pin.

Configuration Inputs Hard-wired configuration pins are available at the TMC8462A, which are used to configure various options related to the hardware configuration and application scenario and which will not change. These pins are PROM_SIZE, PDI_SHARED_SPI_BUS, and DEVICE_EMULATION. More information on these configuration pins and signals is given in Section 4.2 and Section 5.

3.6 Software- and Tool-Support

TRINAMIC's EtherCAT Slave Controller family comes with extensive hardware and software tool support to get started quickly.

Evaluation Board An evaluation board is available for the TMC8462A with standard RJ45 connectors and transformers for interfacing twisted pair copper (TPC) media.

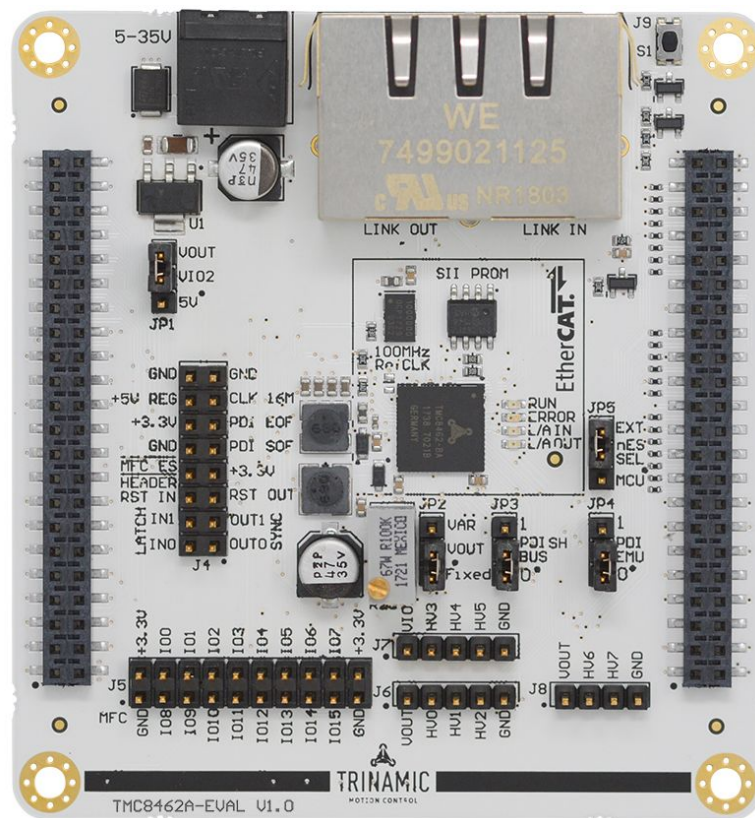

Figure 2: TMC8462A Evaluation Board

The complete board design files are available for download and can be used as reference. All information is available for download on the specific product page on TRINAMIC's website at <http://www.trinamic.com/products/integrated-circuits/evalboards>.

Breakout Board (BOB) Besides the Evaluation board another smaller breakout board is available. It allows for easy integration into own systems or connection to a prototyping platform. The breakout board provides the bus interface along with the ESC and requires an appropriate supply and controller connection. The BOB comes with standard RJ45 connectors to connect to TPC using the TMC8462 ESC with integrated Ethernet PHYs. TMC8462 is functionally equal to the TMC8461. The difference is in using external PHYs vs. integrated PHYs. The complete board design files are available for download and can be used as reference. All information is available for download from the evaluation board section on TRINAMIC's website at <https://www.trinamic.com/support/eval-kits/>.

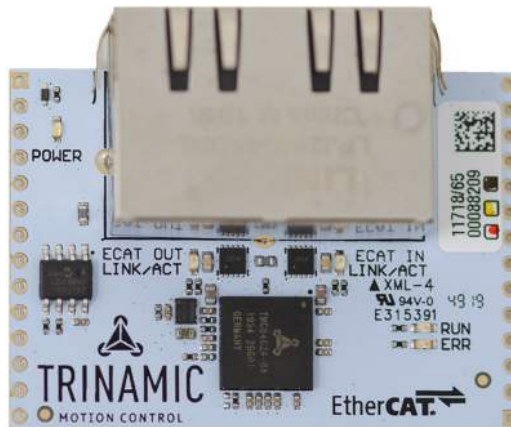

Figure 3: TMC8462 breakout board for RJ45 and TPC

TRINAMIC Technology Access Package In addition, a comprehensive source code and software package – TRINAMIC Technology Access Package (TTAP) – is available for download to get started quickly with own code.

The TTAP is available at <https://www.trinamic.com/support/software/access-package/>.

TMCL-IDE The TMCL-IDE is TRINAMIC’s primary tool (for Windows PCs) to control TRINAMIC modules and evaluation boards. Besides, it provides feature like remote firmware updates, module monitoring options, and specific Wizard support. The TMCL-IDE can be used along with TRINAMIC’s modular evaluation board system.

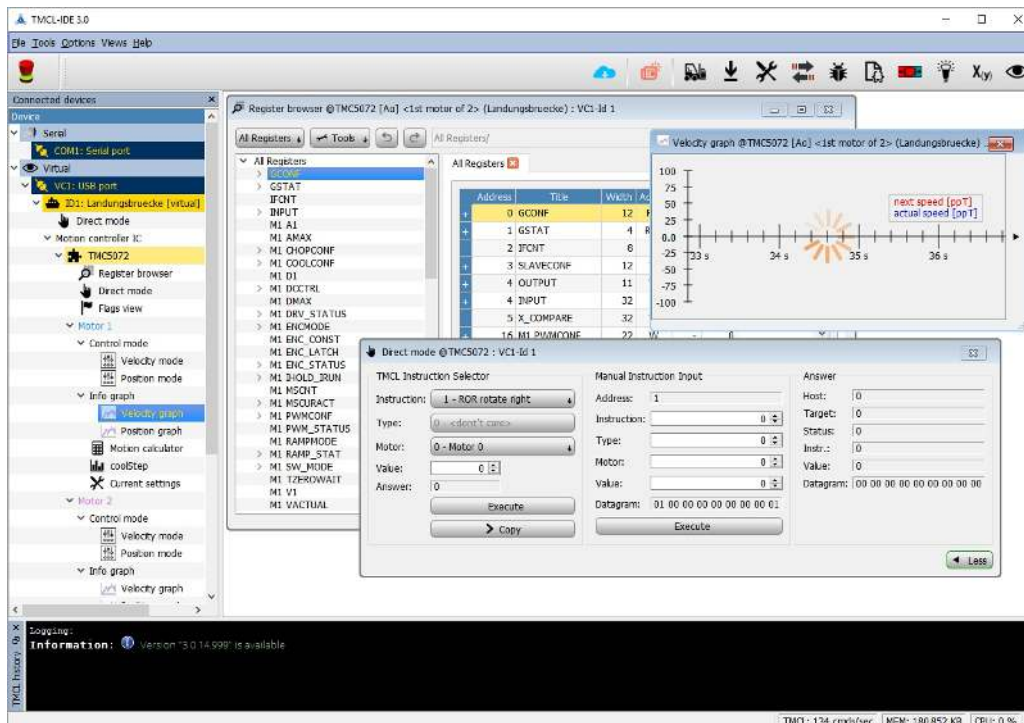

Figure 4: TMCL-IDE

The latest version and additional information is available for download from TRINAMIC’s website at <http://www.trinamic.com/tools/tmcl-ide>.

EtherCAT Slave Configuration Configuration of the EtherCAT Slave Controller is done during boot time with configuration information read from the SII EEPROM after reset or power cycling. This information must be (pre)programmed into the SII EEPROM. This can be done via the EtherCAT master using a so-called EtherCAT Slave Information (ESI) file in standardized XML format. The SII EEPROM can also be (re)written using the local application controller.

ESI Configuration Wizard The TMCL-IDE contains a wizard to assist users with the configuration of the TMC8462A various MFC IO functions. The wizard shows available and allowed options and provides XML code snippets for the ESI file for the SII EEPROM as well as generic C-Code blocks. These can be used as starting point for own firmware development for the application controller.

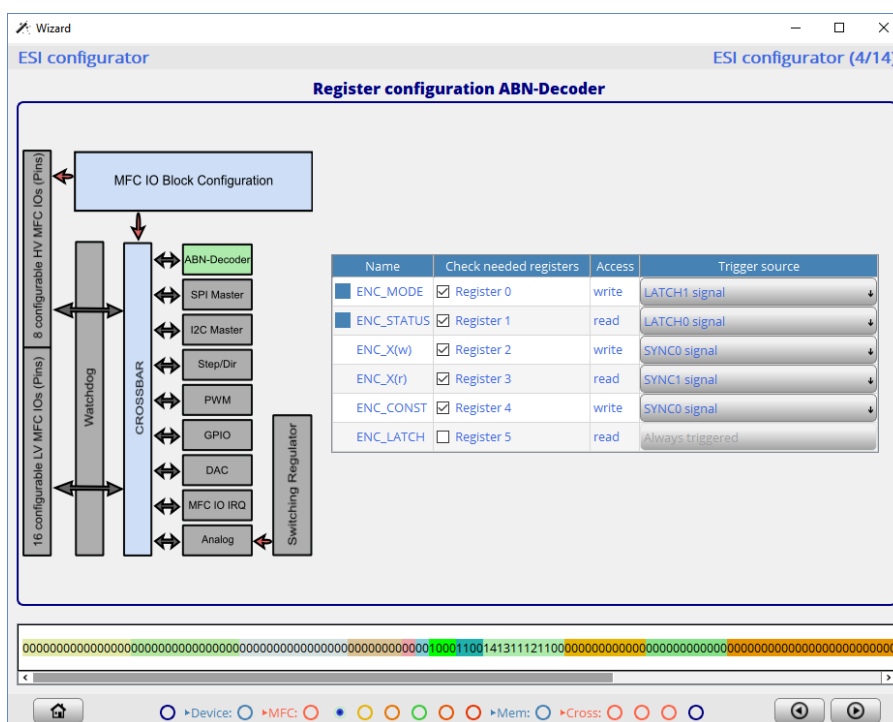

Figure 5: Configuration wizard example – MFC IO block configuration

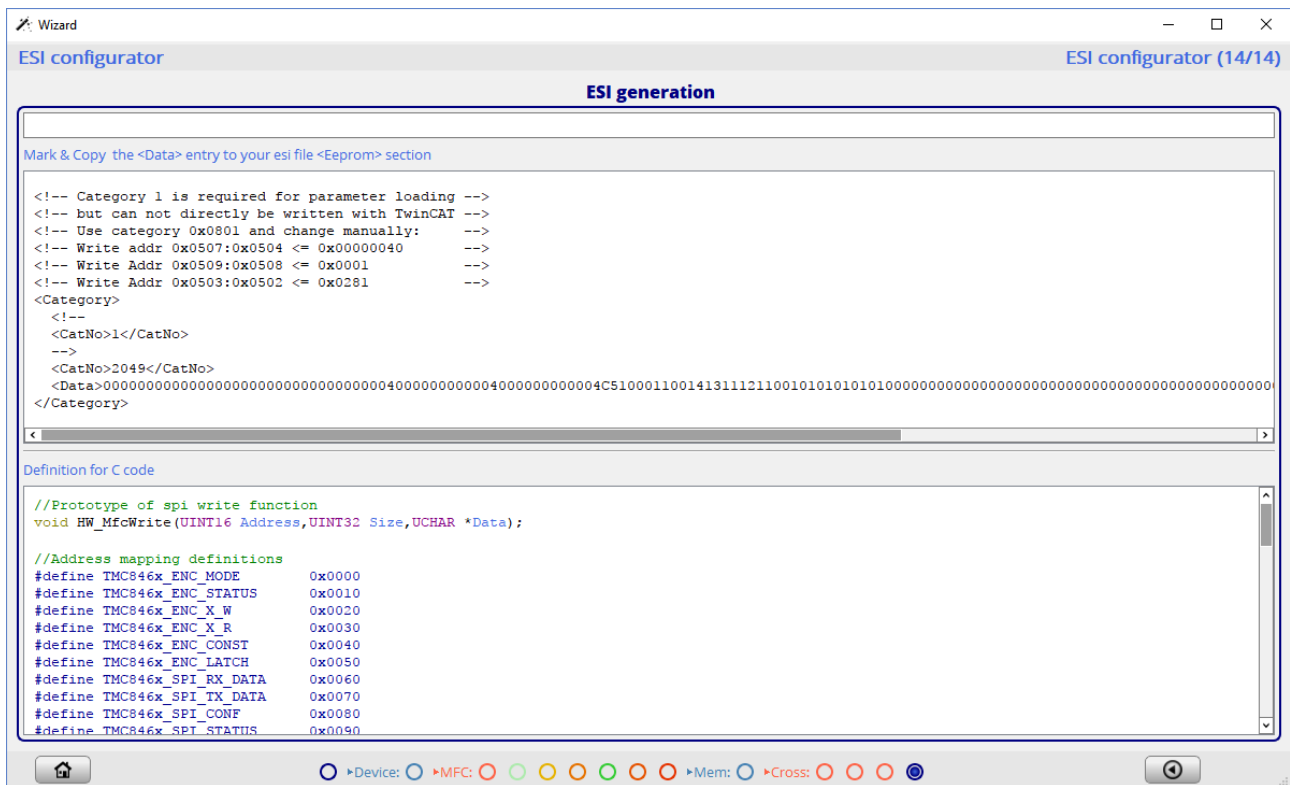

Figure 6: Configuration wizard example – SII EEPROM content and C-code output

4 Device Pin Definitions

4.1 Pinout and Pin Coordinates of TMC8462A-BA

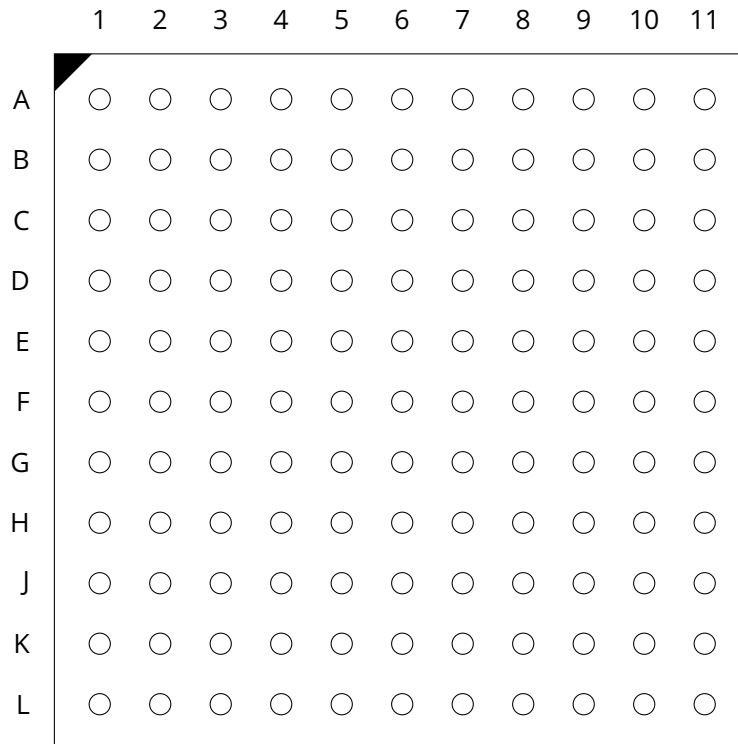

Figure 7: TMC8462A-BA Pinout top view

4.2 Signal Descriptions

Name	Pin	Type (I,O,PU,PD)	Function
General Signals			
NRESET	K4	I/O	Low active system reset. NRESET is an I/O pin. Connected to VCCIO via a 10K resistor and to GND via a 10nF capacitor if no other reset source for proper power-on reset is used. For more information see Section 5.4.1.
REF_CLK25_IN	L3	I	25MHz Reference Clock Input, connect to clock source with <25ppm or better.
CLK16_OUT	H7	O	16.6MHz auxiliary clock output. Not available during reset.
EN_CLK16_OUT	E9	I	Enable signal for CLK16_OUT: 0 = off, 1 = on

Name	Pin	Type (I,O,PU,PD)	Function
RESET_OUT	J4	O	This high-active reset output is activated via EtherCAT register 0x0040), therefore RESET_OUT has to trigger the NRESET input, which clears RESET_OUT. This connection incl. changing the polarity has to be made externally .

Name	Pin	Type (I,O,PU,PD)	Function
EEPROM IOs			
PROM_INIT	J5	O	Signal indicating that EEPROM has been loaded, 0 = not ready, 1 = EEPROM loaded
PROM_CLK	H4	O	External I2C EEPROM clock signal, use 1K pull up resistor to 3.3V
PROM_DATA	H5	I/O	External I2C EEPROM data signal, use 1k pull up resistor to 3V3
PROM_SIZE	G9	I	Selects between two different EEPROM sizes since the communication protocol for EEPROM access changes if a size > 16kBit is used (an additional address byte is required then). 0 = up to 16kBit EEPROM, 1 = 32 kBit-4Mbit EEPROM

DC Synchronization IOs			
SYNC_OUT0	D7	O	Distributed Clocks synchronization output 0, typically connect to MCU
SYNC_OUT1	D6	O	Distributed Clocks synchronization output 1, typically connect to MCU
LATCH_IN0	C7	I	Latch input 0 for Distributed Clocks, connect to GND if not used.
LATCH_IN1	C6	I	Latch input 1 for Distributed Clocks, connect to GND if not used.

LEDs			
LED_RUN	B3	O	Run Status LED, connect to green LED (Anode) 0 = LED off, 1 = LED on
LED_ERR	C3	O	Error Status LED, connect to red LED (Anode) 0 = LED off, 1 = LED on
LINK_ACT0	D3	O	Link In Port Status and Activity, connect to green LED (Anode) 0 = LED off, 1 = LED on
LINK_ACT1	E3	O	Link Out Port Status and Activity, connect to green LED (Anode) 0 = LED off, 1 = LED on

Name	Pin	Type (I,O,PU,PD)	Function
Process Data Interface IOs to/from MCU			
PDI_SOF	H3	O	Ethernet Start-of-Frame if 1
PDI_EOF	G3	O	Ethernet End-of-Frame if 1
PDI_SPI_CSN	L4	I	Chip select signal of the process data interface
PDI_SPI_SCK	K3	I	Serial clock signal of the process data interface
PDI_SPI_MOSI	L5	I	Serial data out signal of the process data interface
PDI_SPI_MISO	K5	O	Serial data in signal of the process data interface
PDI_SPI_IRQ	J3	O	Interrupt signal for primary process data interface, connect to MCU
PDI_WDSTATE	G4	O	EtherCAT Watchdog state, 0: Expired, 1: Not expired
PDI_WDTRIGGER	F4	O	EtherCAT Watchdog trigger if 1
PDI_EMULATION	J7	I	Selects between PDI interface (SPI) or standalone operation with state machine emulation inside ESC. Has weak internal pull down. 0 = default, PDI interface active, 1 = standalone operation, state machine emulation in Slave Controller

MFC IO Control Interface IOs			
MFC_CTRL_SPI_CSN	D4	I	Chip select signal of the MFC IO control interface
MFC_CTRL_SPI_SCK	E4	I	Serial clock signal of the MFC IO control interface
MFC_CTRL_SPI_MOSI	C4	I	Serial data out signal of the MFC IO control interface
MFC_CTRL_SPI_MISO	E7	O	Serial data in signal of the MFC IO control interface
MFC_IRQ	E6	O	MFCIO block IRQ for configurable events, connect to MCU, high active
MFC_NES	C5	I	low active (not) Emergency Stop/Switch/Halt (to bring PWM or other outputs into a safe state), the event must be cleared actively, has weak internal pull down, must be driven high for normal operation
PDI_SHARED_BUS	F9	I	Selects between separate SPI buses (MISO, MOSI, SCK) or one SPI bus with two CS lines for the PDI and MFC CTRL SPI interface: 0 = two separate SPI buses, 1 = one shared SPI bus using the PDI_SPI_x bus lines

Name	Pin	Type (I,O,PU,PD)	Function
MFC IOs			
MFCIO00	J8	I/O	MFCIO block low voltage I/O
MFCIO01	J9	I/O	MFCIO block low voltage I/O
MFCIO02	J10	I/O	MFCIO block low voltage I/O
MFCIO03	J11	I/O	MFCIO block low voltage I/O
MFCIO04	H8	I/O	MFCIO block low voltage I/O
MFCIO05	H9	I/O	MFCIO block low voltage I/O
MFCIO06	H10	I/O	MFCIO block low voltage I/O
MFCIO07	H11	I/O	MFCIO block low voltage I/O
MFCIO08	D8	I/O	MFCIO block low voltage I/O
MFCIO09	D9	I/O	MFCIO block low voltage I/O
MFCIO10	D10	I/O	MFCIO block low voltage I/O
MFCIO11	D11	I/O	MFCIO block low voltage I/O
MFCIO12	C8	I/O	MFCIO block low voltage I/O
MFCIO13	C9	I/O	MFCIO block low voltage I/O
MFCIO14	C10	I/O	MFCIO block low voltage I/O
MFCIO15	C11	I/O	MFCIO block low voltage I/O

MFC High Voltage IOs			
MFC_HV0 (MFCIO16)	A4	I/O	MFCIO block high voltage I/O
MFC_HV1 (MFCIO17)	A5	I/O	MFCIO block high voltage I/O
MFC_HV2 (MFCIO18)	A6	I/O	MFCIO block high voltage I/O
MFC_HV3 (MFCIO19)	A7	I/O	MFCIO block high voltage I/O
MFC_HV4 (MFCIO20)	A8	I/O	MFCIO block high voltage I/O
MFC_HV5 (MFCIO21)	A9	I/O	MFCIO block high voltage I/O
MFC_HV6 (MFCIO22)	A10	I/O	MFCIO block high voltage I/O
MFC_HV7 (MFCIO23)	A11	I/O	MFCIO block high voltage I/O

Name	Pin	Type (I,O,PU,PD)	Function
MFC High Voltage IO Supplies			
VIO1	B5	I	MFCHVIO block 1 supply voltage
VIO2	B7	I	MFCHVIO block 2 supply voltage
VIO3	B9	I	MFCHVIO block 3 supply voltage
GNDIO1	B6	I	MFCHVIO block 1 ground, connect to GND
GNDIO2	B8	I	MFCHVIO block 2 ground, connect to GND
GNDIO3	B10	I	MFCHVIO block 3 ground, connect to GND

Device Supply and Ground			
VS	B11	I	Supply voltage, use a 100nF filter capacitor
VCCIO	E10, F10, G10, F11	I	I/O supply voltage, use a 100nF filter capacitor per pin
VCC_CORE	F6, G6, F7, G7	I	Core supply voltage, connect to VDD1V8_OUT, use a 100nF filter capacitor per pin
PLLCLK_VCCIO	K6	I	PLL supply voltage, connect to VCCIO through a filter (R/L/C)
GND	C1, F1, J1, A3, B4, F5, G5, E8, F8, G8	I	Supply Ground
PLLCLK_GND	J6	I	PLL supply ground, connect to GND

Voltage Regulator IOs			
VDD1V8_OUT	G11	O	Output of internal 1.8V regulator, use a 100nF filter capacitor
VDD5_OUT	E11	O	Output of internal 5V regulator, use a 100nF filter capacitor if VS ≥ 5V

Name	Pin	Type (I,O,PU,PD)	Function
Switching Regulator 0 IOs			
VS0	L7	I	Switching regulator 0 supply voltage, Switching regulator 0 provides a fixed 3.3V output. Leave open if not used.
GND0	L9	I	Switching regulator 0 ground, connect to GND
SW0	L8	O	Switching regulator 0 output, fixed 3.3V, Leave open if not used.
SW_DIODE	K7	I	Switching regulator 0 internal diode, connect to SW0 only if VS0 is at or below 5V
GND_DIODE	K8	I	Switching regulator 0 internal diode ground, connect to GND

Switching Regulator 1 IOs			
VS1	L11	I	Switching regulator 1 supply voltage, Switching regulator 1 provides an adjustable output voltage. Leave open if not used.
GND1	K9	I	Switching regulator 1 ground, connect to GND
SW1	L10	O	Switching regulator 1 output, adjustable, Leave open if not used.
VOUT	K10	I	Switching regulator 1 inductor ringing suppression feedback
VOUT_FB	K11	I	Switching regulator 1 feedback voltage, 1.2V typically, Leave open if not used.

Bus Interface 0 IOs (EtherCAT IN Port)			
TN0	D1	O	Negative pin of differential transmit output pair
TP0	E1	O	Positive pin of differential transmit output pair
RN0	A1	I	Negative pin of differential receive output pair
RP0	B1	I	Positive pin of differential receive output pair
REGOUT0	A2	O	Regulator power output, use a 10uF and 0.1uF for filtering power noise
MCLK	F2	O	PHY management clock, leave open if not needed
MDIO	F3	I/O, PU	PHY management data, use 4K7 pull up resistor to VCCIO (3.3V)

Name	Pin	Type (I,O,PU,PD)	Function
Bus Interface 1 IOs (EtherCAT OUT Port)			
TN1	K1	IO	Negative pin of differential transmit output pair
TP1	L1	IO	Positive pin of differential transmit output pair
RN1	G1	IO	Negative pin of differential receive output pair
RP1	H1	IO	Positive pin of differential receive output pair
REGOUT1	L2	O	Regulator power output, use a 10uF and 0.1uF for filtering power noise

Test Pins only			
TST_MODE	E5	I	Test mode enable, connect to GND
TST_ANA	D5	O	Analog test output, leave open
TSTCLK_SELECT	H6	I	Test input, always connect to GND for normal operation
RXCLK0	D2	IO	Clock test pin, leave open
RXCLK1	G2	IO	Clock test pin, leave open
TXCLK0	E2	IO	Clock test pin, leave open
TXCLK1	H2	IO	Clock test pin, leave open
RXDV0	B2	I, PD	Test pin, leave open for normal operation
RXDV1	K2	I, PD	Test pin, leave open for normal operation
TXER0	C2	I, PD	Test pin, leave open for normal operation
TXER1	J2	I, PD	Test pin, leave open for normal operation
CLKO_100	L6	O	100MHz clock output

Table 2: Pin and Signal description for TMC8462A-BA

5 Device Usage and Handling

5.1 Process Data Interface

The Process Data Interface (PDI) is an SPI interface with a clock frequency of up to 30 MHz. The ESC registers and the process data RAM can be accessed from an external microcontroller using this interface. The interface can be configured via the EEPROM, however it is recommended to use the default configuration (SPI mode 3 with low active chip select). For further details, see the ESC SPI slave configuration registers in Section 6.

Additionally, some signals are available that can be evaluated by the application controller.

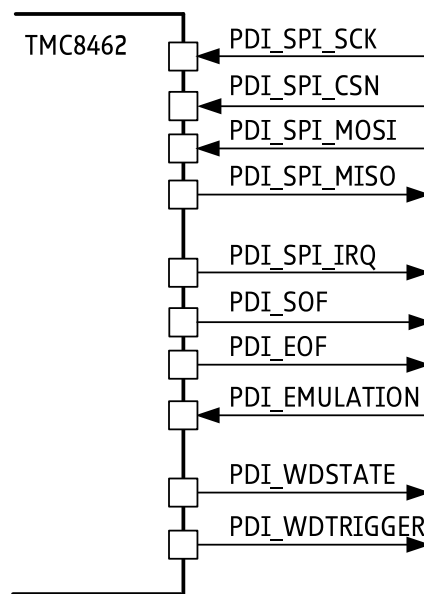

Figure 8: PDI control signals

TMC8462A pin	Description	Typical pin on a MCU
PDI_SPI_CSN	SPI chip select for the TMC8462A PDI	SSx
PDI_SPI_SCK	SPI master clock	SCK
PDI_SPI_MOSI	Master out slave in data	MOSI
PDI_SPI_MISO	Master in slave out data	MISO
PDI_SPI_IRQ	Configurable IRQ from PDI	General purpose Input
PDI_EMULATION	0: default mode for complex slaves, state machine changes processed in microcontroller firmware (SSC); 1: device emulation mode for, e.g., simple slaves, state machine changes directly handled in the ESC	General purpose Output or connected to either ground or 3.3V.
PDI_SOF	Indicates start of an Ethernet/EtherCAT frame (MII_RXDV = '1')	General purpose Input

TMC8462A pin	Description	Typical pin on a MCU
PDI_EOF	Indicates end of an Ethernet/EtherCAT frame	General purpose Input
PDI_WDSTATE	0: Watchdog expired; 1: Watchdog not expired	General purpose Input
PDI_WDTRIGGER	Watchdog triggered if '1'	General purpose Input

Table 3: PDI signal description

5.1.1 SPI protocol description

Each SPI datagram contains a 2- or 3-byte address/command part and a data part. For addresses below 0x2000, the 2-byte addressing mode can be used, the 3 byte addressing mode can be used for all addresses.

C2	C1	C0	Command
0	0	0	NOP (no operation, no following data bytes)
0	0	1	Reserved
0	1	0	Read
0	1	1	Read with wait state byte
1	0	0	Write
1	0	1	Reserved
1	1	0	Address extension, signaling 3 byte mode
1	1	1	Reserved

Table 4: PDI SPI commands

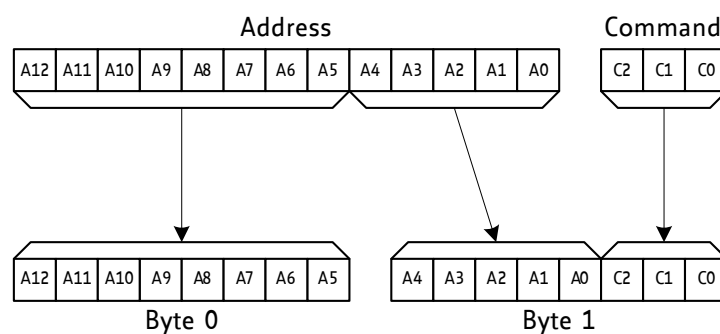

Figure 9: PDI SPI 2 byte addressing

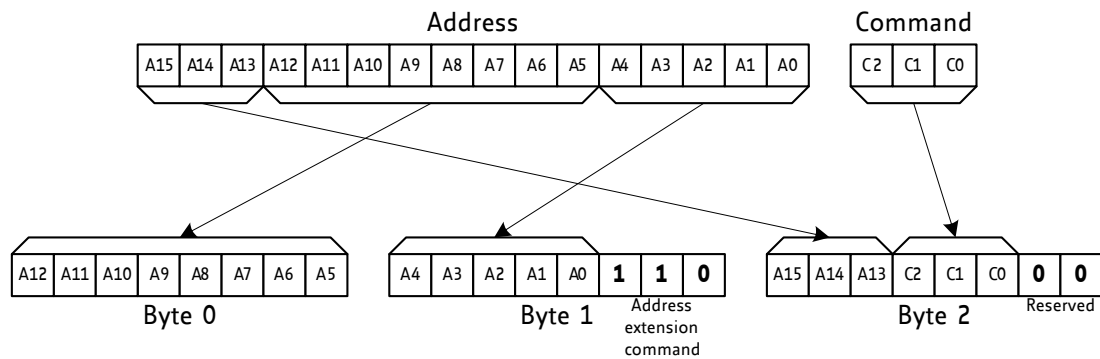

Figure 10: PDI SPI 3 byte addressing

Unless highest performance is required, using only the 3-byte addressing mode and the read with wait state command is recommended since it reduces the need for special cases in the software. During the address/command bytes, the ESC replies with the contents of the event request registers (0x0220, 0x0221 and in 3 byte addressing mode 0x0222).

Command 0 - NOP

This command can be used for checking the event request registers and resetting the PDI watchdog without a read or write access.

Example datagram: 0x00 0x00

Example reply (AL Control event bit is set): 0x01 0x00

Command 2 - READ

With the read command, an arbitrary amount of data can be read from the device. The first byte read is the data from the address given by the address/command bytes. With every read byte, the address is incremented. During the data transfer, the SPI master sends 0x00 except for the last byte where a 0xFF is sent.

When using this command, a pause of 240ns or more must be included between the address/command bytes and the data bytes for the ESC to fetch the requested data.

Example datagram (Read from address 0x0120 and 0x0121): 0x09 0x02 0x00 0xFF

Example reply (Operational State requested): 0x01 0x00 0x08 0x00

Command 3 - READ WITH WAIT STATE BYTE

This command is similar to the Read command with an added dummy byte between the address/command part and the data part of the datagram. This allows enough time to fetch the data in any case.

Example datagram (Read starting at address 0x3400): 0xA0 0x06 0x2C 0xFF 0x00 0x00 0x00 0xFF

Example reply (0xXX is undefined data): 0x00 0x00 0x00 0xXX 0x44 0x41 0x54 0x41

Command 4 - WRITE

The write command allows writing of an arbitrary number of bytes to writable ESC registers or the process data RAM. It requires no wait state byte or delay after the address/command bytes. After every transmitted byte, the address is incremented.

Example datagram (Write starting at address 0x4200): 0x10 0x06 0x50 0x4C 0x48

Example reply (0xXX is undefined data): 0x00 0x00 0x00 0xXX 0xXX

Address 0x4200 now contains 0x4C, Address 0x4201 contains 0x48

Command 6 - ADDRESS EXTENSION

The address extension command is mainly used for the 3-byte addressing mode as shown in Figure 10. For SPI masters that can only process datagrams with an even number of bytes, it might be necessary to pad the datagram to an even number of bytes. This can be achieved by duplicating the third byte of the 3-byte address/command part and using the address extension command in all but the last duplicate. For example, a SPI master that is only capable of transmitting a multiple of 4 bytes cannot use the example datagram for a write access above since it contains 5 bytes. With three added padding bytes, the master has to transmit two 4-byte groups.

Example datagram (Write starting at address 0x4200): 0x10 0x06 0x58 0x58 0x58 0x50 0x4C 0x48
 Example reply (0xXX is undefined data): 0x00 0x00 0x00 0xXX 0xXX 0xXX 0xXX 0xXX

5.1.2 Timing example

This example shows a generic read access with wait state and 2 byte addressing. All configurable options are shown. The delays between the transferred bytes are just to show the byte boundaries and are not required.

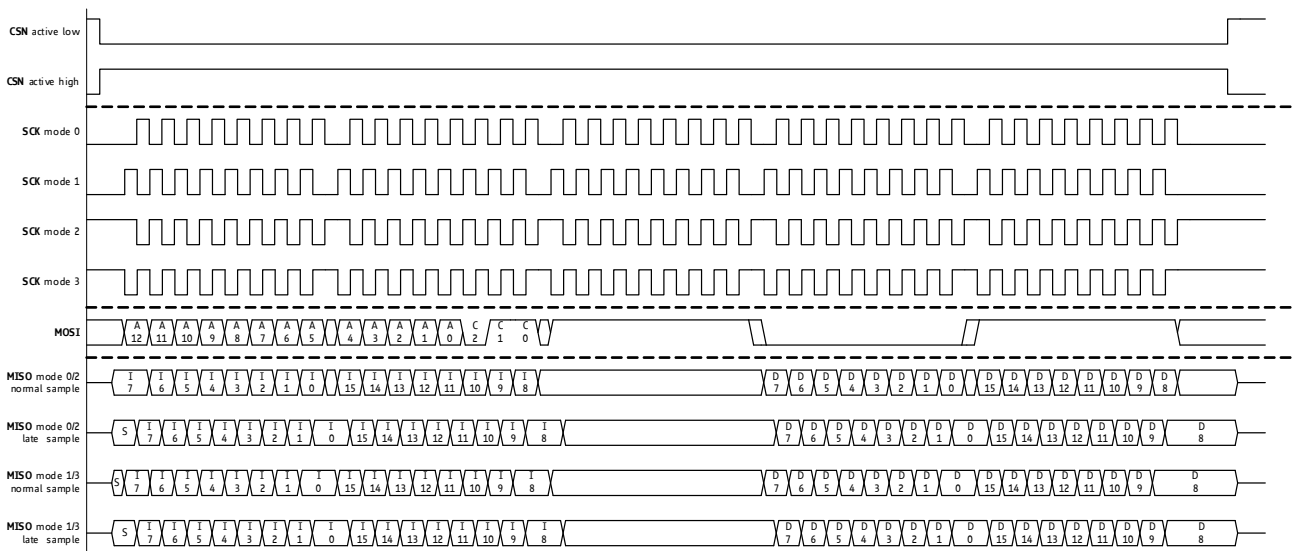

Figure 11: SPI timing example

5.2 MFC IO Control Interface

The MFC IO block of the TMC8462A comes with a dedicated SPI slave interface to allow direct access from a local application controller. It is called MFC CTRL SPI interface. This interface to the MFC IO block's functions is always available, even if the EtherCAT state machine is currently not in operational state (OP). Protocol structure and timing are identical to the PDI SPI.

The MFC Control SPI is a SPI mode 3 slave with low active chip select. The SPI clock frequency can be up to 30MHz. The following diagram shows all signals related to the MFC CTRL SPI interface.

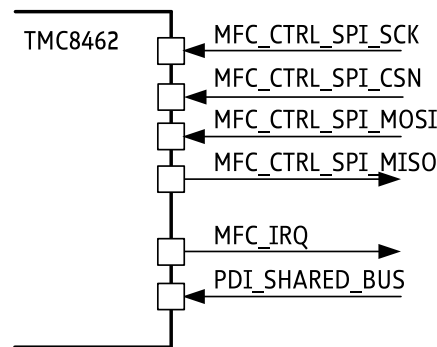

Figure 12: MFC control signals

TMC8462A pin	Description	Typical pin on a MCU
MFC_CTRL_SPI_CSN	SPI chip select for the TMC8462A PDI	SSx
MFC_CTRL_SPI_SCK	SPI master clock	SCK
MFC_CTRL_SPI_MOSI	Master out slave in data	MOSI
MFC_CTRL_SPI_MISO	Master in slave out data	MISO
MFC_IRQ	Configurable IRQ from MFC IO block	General purpose Input
PDI_SHARED_BUS	0: separate SPI buses for PDI and MFC CTRL; 1: shared/common SPI bus for PDI and MFC CTRL with 2 CSN signals using the PDI SPI bus. The SPI bus signals MFC_CTRL_SPI_SCK, MFC_CTRL_SPI_MISO, MFC_CTRL_SPI_MOSI can be left open in this case	General purpose Output or connected to either ground or 3.3V.

Table 5: MFC CTRL SPI signal description

5.2.1 SPI Protocol description

The protocol of the MFC CTRL SPI is the same as the PDI SPI interface (see section 5.1.1) The addresses for register access are calculated using the register number and the byte number in each register. To calculate the address, the register number is shifted left by 4 bits and the byte number is added as the 4 lowest bits.

Access using the 3 byte addressing mode is possible, and can be used when 2 byte mode is not implemented for the PDI SPI but since the highest bits of the address are always 0, accessing the MFC Control SPI via 2 byte mode is sufficient.

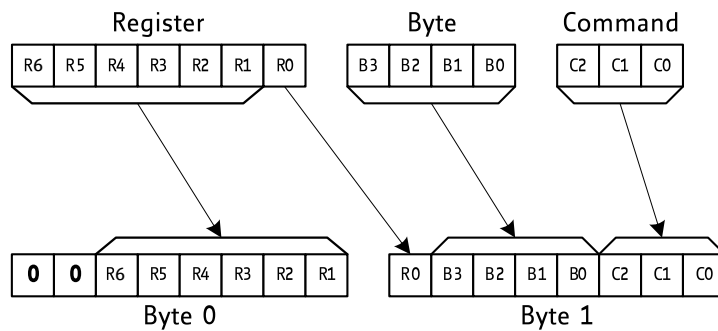

Figure 13: MFC CTRL SPI 2 byte addressing

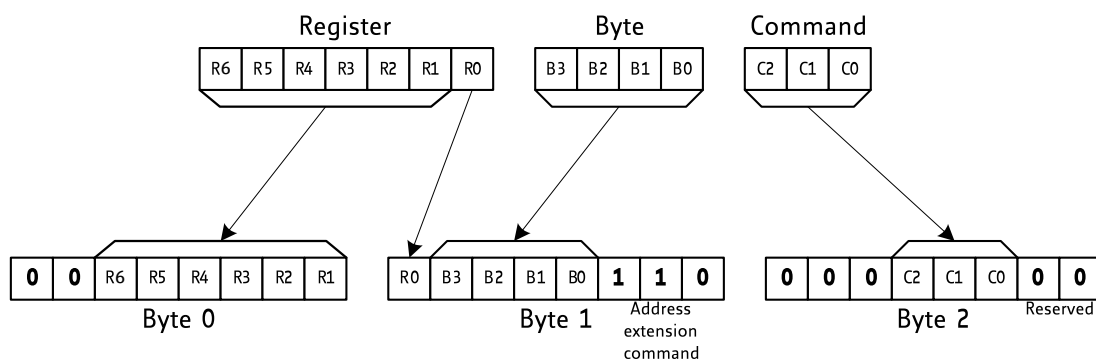

Figure 14: MFC CTRL SPI 3 byte addressing

5.2.2 Timing example

This example shows a generic MFC register read access with wait state. The delays between the transferred bytes are just to show the byte boundaries and are not required.

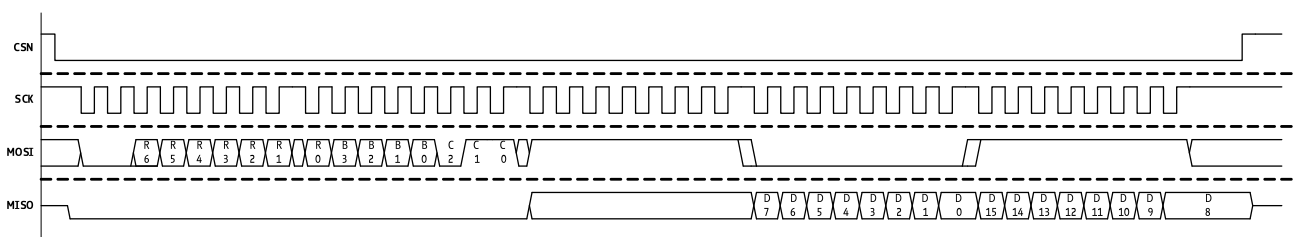

Figure 15: MFC SPI timing example

5.2.3 Sharing Bus Lines with the PDI SPI

To reduce the number of signals on the PCB or if the local application controller has only one SPI interface, the MFC CTRL SPI bus can share the SPI bus signals of the PDI SPI, requiring only separate chip select signals. In this case, both interfaces are internally switched to the PDI SPI interface pins. The original MFC CTRL SPI signals (MOSI, MISO, and SCK) remain unconnected in this case. Only the MFC_CTRL_SPI_CSN pin/signal must be used if the MFCIO block is accessed.

To share the SPI bus lines, configuration pin PDI_SHARED_BUS must be pulled high as shown in the figure below.

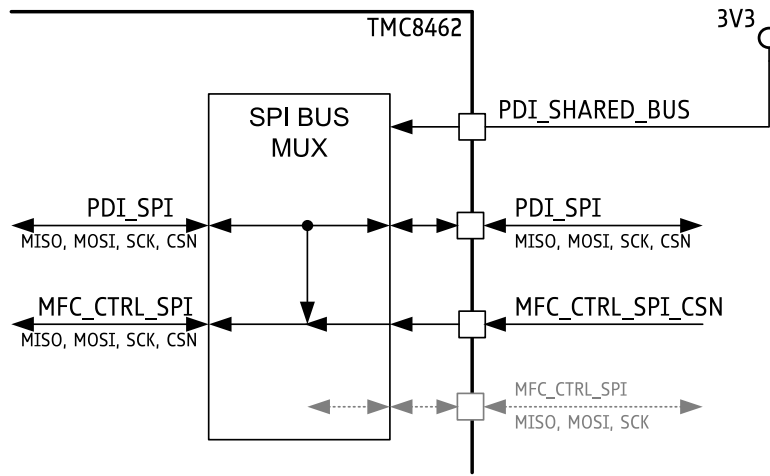

Figure 16: SPI bus sharing

5.3 Ethernet Physical Layer Connection

TMC8462A comes with two integrated 100-MBit Ethernet PHYs eliminating the need for external PHY components. The physical media interface can connect to (shielded) twisted pair copper buses ((S)TPC). Port signals with index 0 represent the EtherCAT IN port. Port signals with index 1 represent the EtherCAT OUT port.

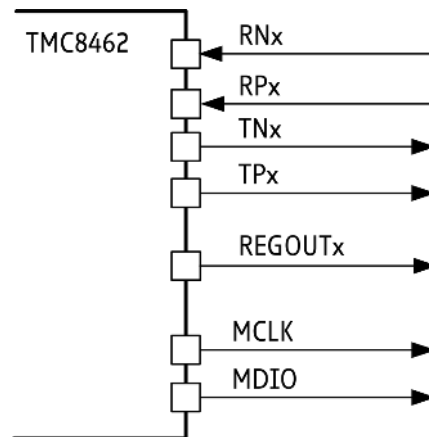

Figure 17: Physical bus interface pins

TMC8462A pin	Description
TNx	Negative pin of differential transmit output pair
TPx	Positive pin of differential transmit output pair
RNx	Negative pin of differential receive output pair
RPx	Positive pin of differential receive output pair
REGOUTx	This is a regulator power output. A 10uF and 0.1uF should be connected to this pin for filtering power noise.
MCLK	PHY configuration clock output
MDIO	PHY configuration data in-/output

Table 6: Physical bus interface pin description

5.4 External Circuitry and Applications Examples

5.4.1 Device Reset

The NRESET signal should at least be connected to VCCIO via a 10K resistor and to GND via a 10nF capacitor if no other controlled reset source for proper power-on behavior and reset is used.

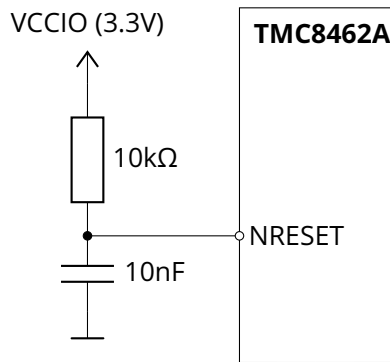

Figure 18: Minimum external circuit for power-on reset

5.4.2 Supply Filtering for PLL Supply

The internal PLL is supplied with the same 3.3V as used for VCCIO. An R/L/C filter structure as shown in the circuit diagram is used. PLLCLK_GND is connected to common ground. Pin TSTCLK_SELECT must be connected to common ground.

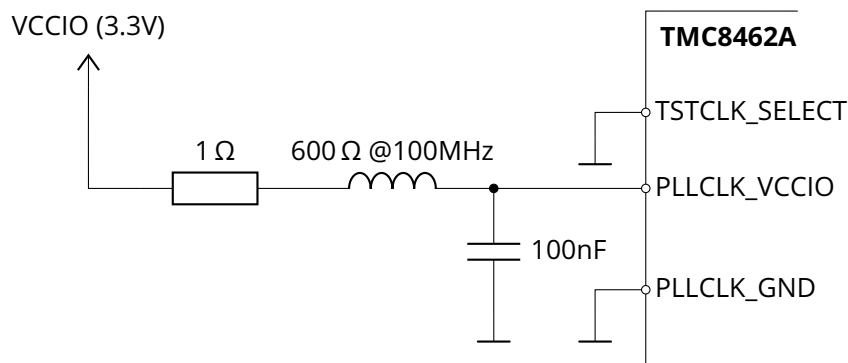

Figure 19: PLL supply filter

5.4.3 PHY Power Regulator Filtering

The internal PHY circuits require external filter capacitors.

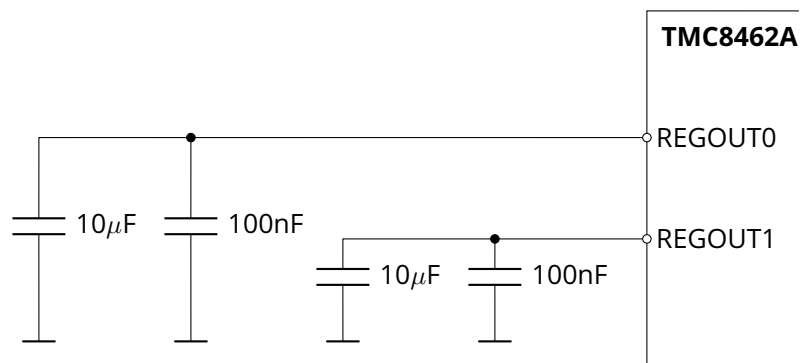

Figure 20: PHY power regulator filtering

5.4.4 External Circuit for Fixed Switching Regulator 0

Switching regulator 0 is an internal buck switching regulator and generates a fixed 3.3V supply with approximately 500mA. This 3.3V supply shall be used to power VCCIO and PLLCLK_VCCIO. This regulator comes with an integrated Schottky diode which minimizes part count, when an external 5V supply is available. This 3.3V can also be used to power other on-board devices, e.g., EEPROM or LEDs. The 3.3V rail is available at switching regulator 0 output SW0.

More information on the switching regulators is given in Section 7.21.

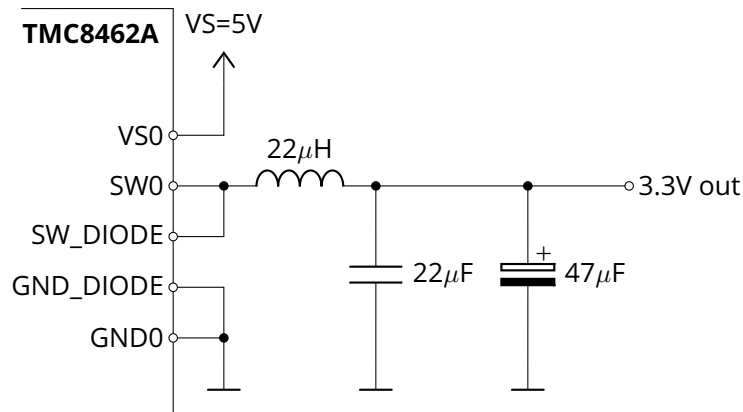

Figure 21: External circuit for switching regulator 0 with $VS0 = 5V$

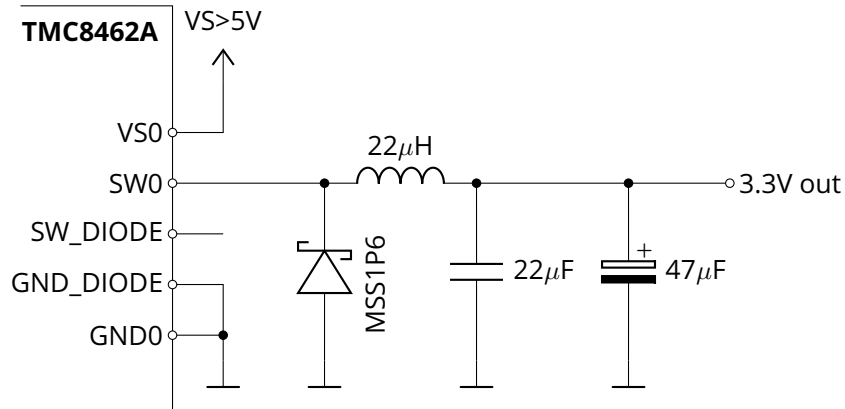

Figure 22: External circuit for switching regulator 0 with $VS0 > 5V$

5.4.5 External Circuit for Adjustable Switching Regulator 1

Switching regulator 1 is an internal buck switching regulator and generates an adjustable supply rail with approximately 500mA. The voltage at SW1 can be adjusted using a resistor network in the switching regulator's feedback path at VOUT_FB. VOUT_FB should be at 1.2V using a resistor divider. SW1 can be used to power the high voltage IOs using VIO1, VIO2, VIO3 as well as switching regulator 0 input VS0 (which generates a fixed 3.3V rail). SW1 can also be used to power other peripheral devices, e.g., Hall signals of a BLDC motor or external encoders.

More information on the switching regulators is given in Section 7.21.

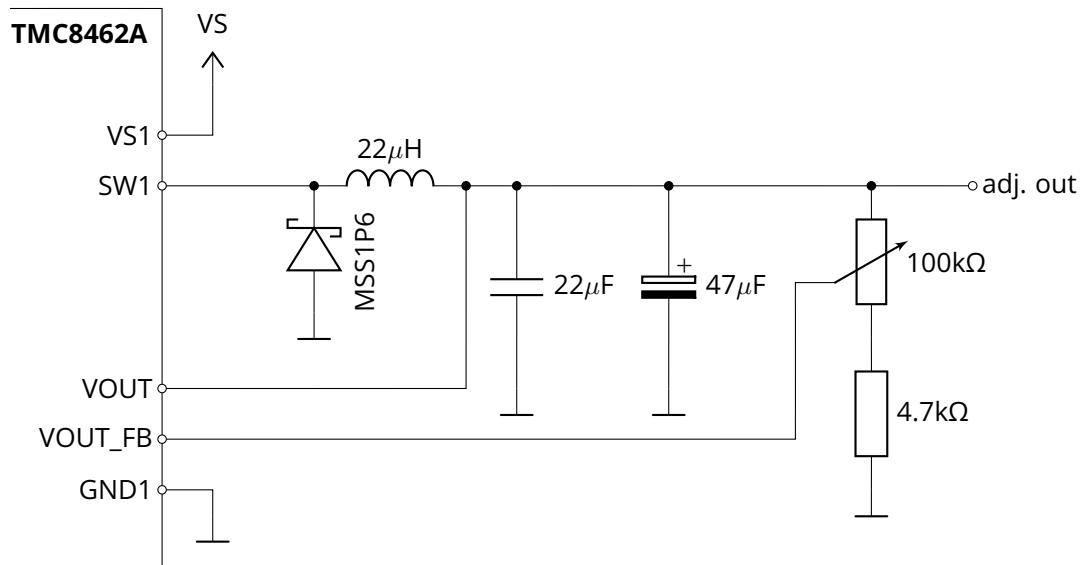

Figure 23: External circuit for adjustable buck regulator

5.4.6 Minimum External Supply Circuit for Single 3.3V Supply

The diagram shows the minimum external circuit when using a single 3.3V supply only.

Both internal switching regulators are not used in this example. Therefore, both supply ports VS0 and VS1 are not connected.

The high voltage IOs are also not used in this example. Therefore, the three high voltage IO supply ports VIO1, VIO2, and VIO3 are not connected.

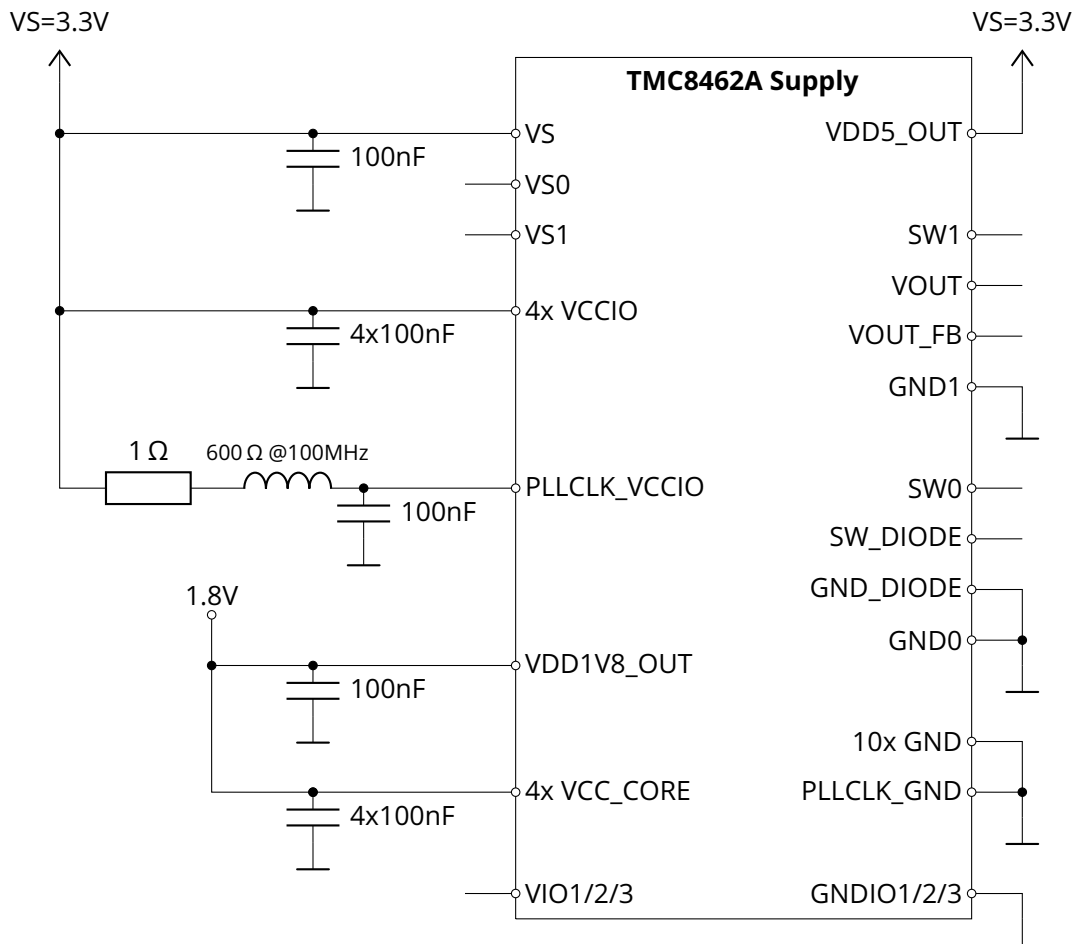

Figure 24: Minimum external supply circuit for single 3.3V supply

5.4.7 Minimum External Circuit for Single 5V Supply

The diagram shows the minimum external circuit when using a single 5V supply only. Switching regulator 0 is used to generate the 3.3V for VCCIO and PLLCLK_VCCIO. Switching regulator 1 is not used in this example. Therefore, supply port VS1 is not connected. The high voltage IOs are also not used in this example. Therefore, the three high voltage IO supply ports VIO1, VIO2, and VIO3 are not connected.

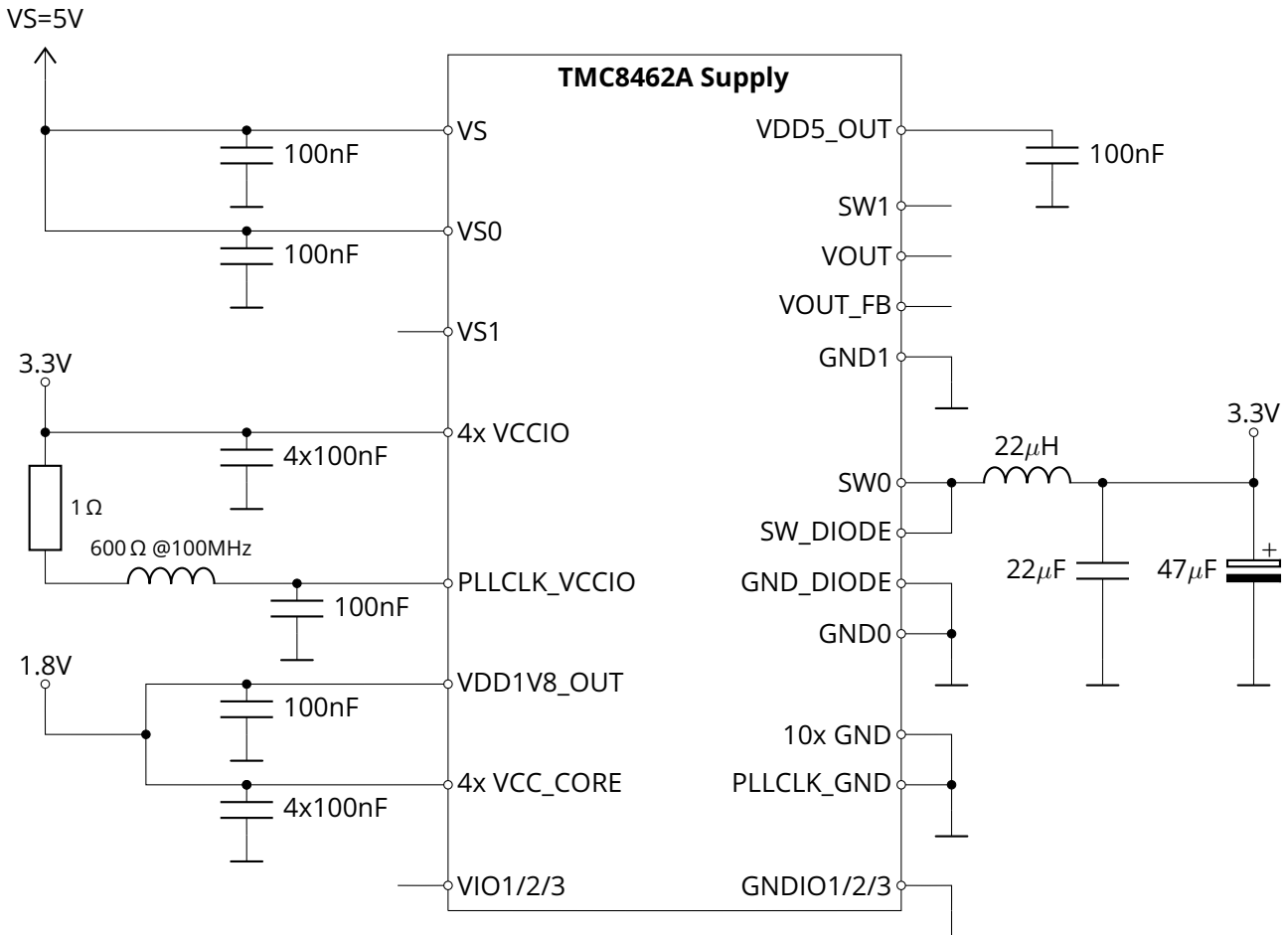

Figure 25: Minimum external supply circuit for single 5V supply

5.4.8 Minimum External Supply Circuit for Single Supply >5V

To connect TMC8462A to a single supply greater than 5V the circuit is very similar to Figure 25. The main difference is that an additional external diode (MSS1P6) is required at output SW0. The pin SW_DIODE is open.

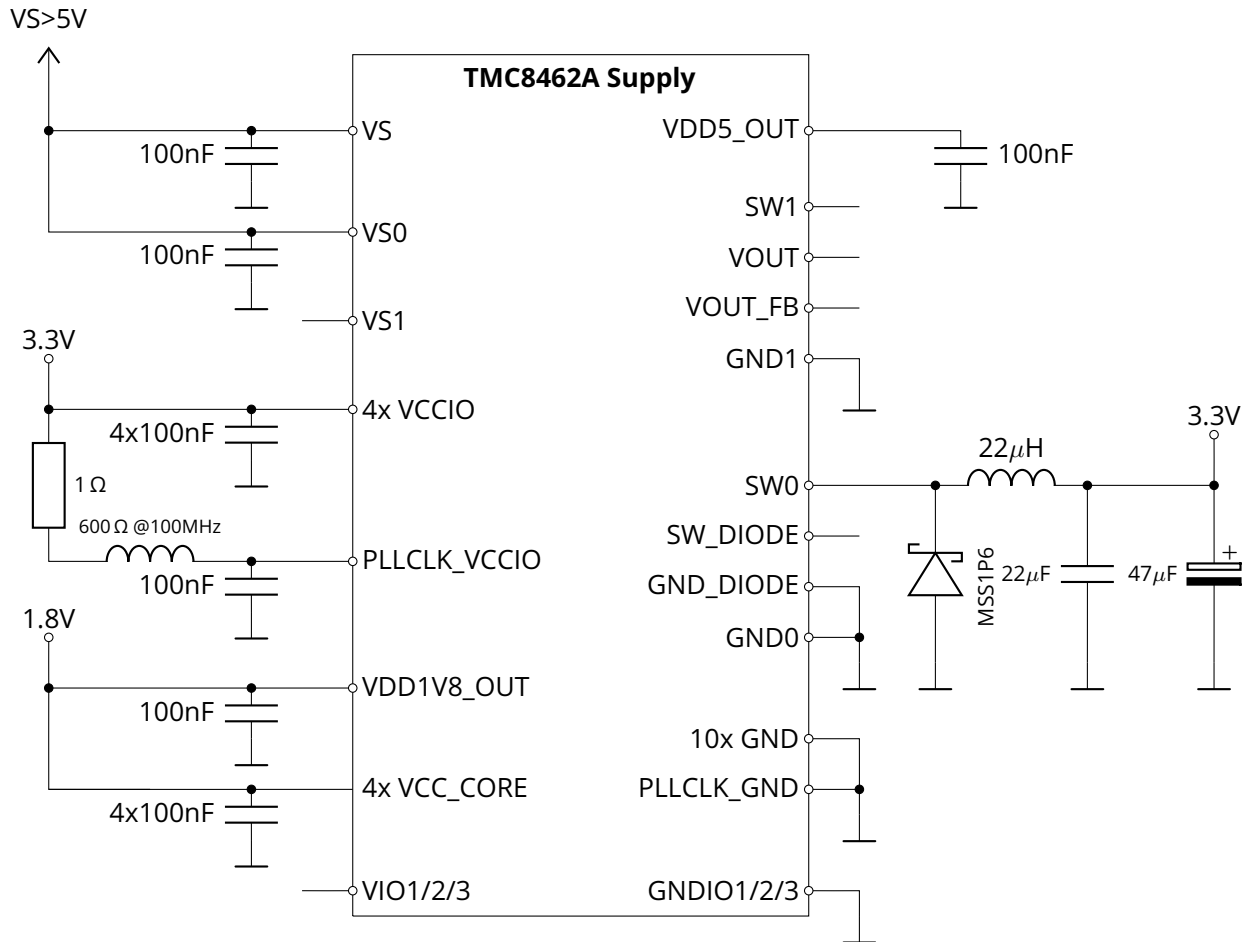

Figure 26: Minimum external supply circuit for single supply >5V

5.4.9 Typical Power Supply Chain Using Both Buck Converters

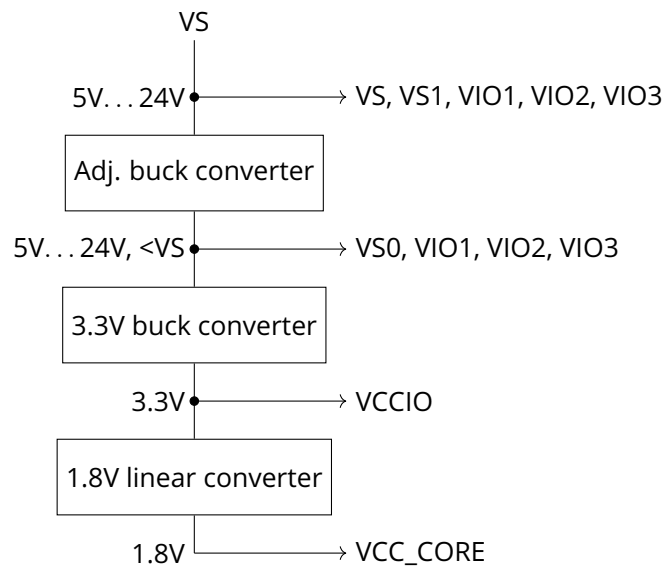

Figure 27: Typical power supply chain using both buck converters

5.4.10 Status LED Circuit

The TMC8462A has 4 status LED outputs. All outputs are supplied from VCCIO (3.3V), and drive a LED with current limiting resistor to GND. The use of low current LED is recommended to keep supply current low and to stay within the current limit of 10mA per pin. The appropriate resistor value must be chosen for the selected LED's forward voltage.

For a 2V forward voltage at 2mA, a value of 680 Ohm is a reasonable value.

The LED colors are defined by **ETG.1300** (available on www.ethercat.org).

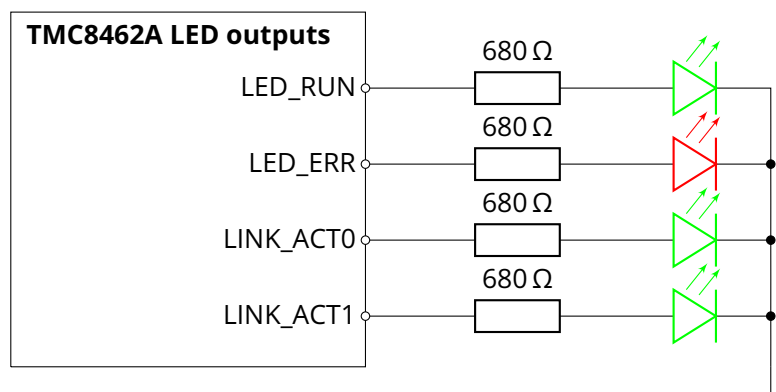

Figure 28: Status LED circuit

5.4.11 SII EEPROM Circuit

An I²C EEPROM is required for operation with the SII interface. Its size can be up to 4MBit. While the access protocol of the I²C EEPROMs is standardized, the addressing procedure changes from one address

byte up to 16kBit to two address bytes from 32kBit. Up to 16kBit the PROM_SIZE pin must be tied to GND, above that, it must be tied to VCCIO (3.3V).

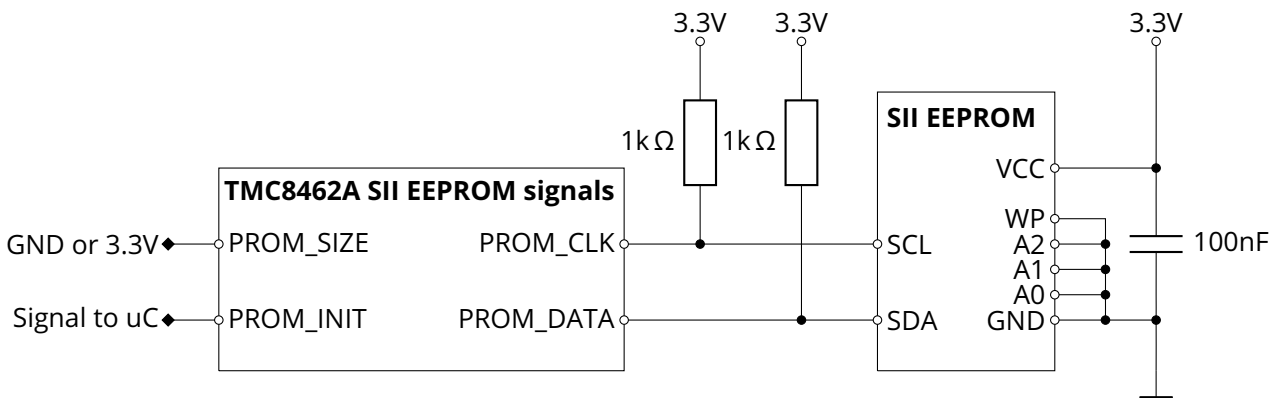

Figure 29: SII EEPROM circuit (shown for EEPROMs >32kBit)

5.4.12 Considerations on PHY to PHY Connection

In applications with multiple EtherCAT slave controllers in one enclosed device or even on the same PCB, it is not always necessary to connect the slave controllers via magnetics, RJ-45 connectors (or similar) and a patch cable. Instead a direct backbone connection or traces on the PCB can be used to directly link the PHYs, however coupling capacitors must be used in the connection.

This option reduces the cost as well as the required space in the setup.

Note

This connection method should be used only over short distances with no or few connectors in between. It is not recommended for longer distances, especially using a wired connection.

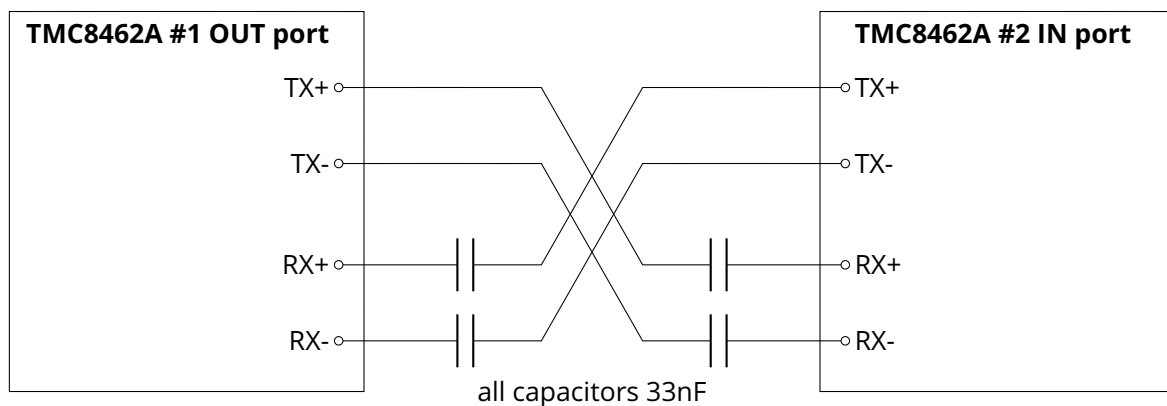

Figure 30: Direct PHY to PHY connection

6 EtherCAT Slave Controller Description

6.1 General EtherCAT Information

TMC8462A contains a standard-conform EtherCAT Slave Controller (ESC) providing real-time EtherCAT MAC layer functionality to EtherCAT slave devices. The ESC part of TMC8462A provides the following EtherCAT-related features:

- 16 KByte of Process Data RAM (PDRAM): The PDRAM is a dual ported RAM, which allows exchange of data between the EtherCAT master and the local application.
- Eight Sync Managers (SM): Sync Managers are used to control and secure the data exchange via the PDRAM in terms of data consistency, data security, and synchronized read/write operations on the data objects. Two modes –buffered mode and mailbox mode – are available.
- Eight Fieldbus Memory Management Units (FMMU): FMMUs are used for mapping of logical addresses to physical addresses. The EtherCAT master uses logical addressing for data than spans multiple slaves. An FMMU can map such a logical address range to a continuous local physical address range.
- 64 bit Distributed Clock support (DC): DC is the base of the real-time capability of EtherCAT. Their underlying algorithms compute delay times between the master and the slaves and between slaves and update a common time stamp in all slaves. This way, synchronized time stamps (LATCH0/1) and synchronized trigger signals (SYNC0/1) are available in every slave and to the master.
- IIC interface for external SII EEPROM for ESC configuration: After reset and at power up, the ESC requires reading basic (and advanced) configuration data from an external SII EEPROM to properly configure interfaces, operation modes, and and feature availability. The SII EEPROM may be read and written by the master or the local application controller as well.
- SPI Process Data Interface (PDI): The PDI is the interface between the local application controller and the ESC. Application-specific process data and EtherCAT control and status information for the EtherCAT State Machine (ESM) is exchanged via this interface.
- Device Emulation Mode: This mode is a special mode of operation where no ESM in the application controller is required. The slave's operation states are simply directly set by the master without control of an ESM. This is beneficial for small and simple slaves, for example simple IO devices.

To manufacture own slaves devices, a registration with the EtherCAT Technology Group (ETG) is required. More information and resources on the EtherCAT technology and the EtherCAT standard are available here:

- EtherCAT Technology Group (ETG) (<http://www.ethercat.org/>)
- EtherCAT is standardized by the IEC (<http://www.iec.ch/>) and filed as IEC-Standard 61158.

6.2 Overview of Available Chip Features

The following table shows EtherCAT chip features available in TRINAMIC's EtherCAT slave controller solutions.

Chip Feature / Description	Domain	TMC8460	TMC8461	TMC8462	TMC8670
Extended DL control register 0x0102:0x0103 enabled	Register	1	1	1	1
AL Status code register 0x0134:0x0135 enabled	Register	1	1	1	1
ECAT interrupt mask 0x0200:0x0201 enabled	Register	1	1	1	1
Configured station alias 0x0012:0x0013 enabled	Register	1	1	1	1
General purpose inputs 0x0F18:0x0F1F enabled	Register	0	0	0	0
General purpose outputs 0x0F10:0x0F17 enabled	Register	0	0	0	0
AL event mask 0x0204:0x0207 enabled	Register	1	1	1	1
Physical RD/WR offset 0x0108:0x0109 enabled	Register	0	1	1	0
Bridge port PDI (0x07) enabled	Register	0	0	0	0
Writable Watchdog divider 0x0400:0x0401 and Watchdog PDI 0x0410:0x0411 enabled	Watchdog	1	1	1	0
Watchdog counters 0x0442:0x0444 enabled	Watchdog	1	1	1	1
ECAT write protection 0x0020:0x0031 enabled	Ext. Function	0	1	1	0
Reset registers 0x0040:0x0041 enabled	Ext. Function	1	1	1	1
FPGA update at 0x0E00 enabled	Ext. Function	0	0	0	0
DC Sync event times enabled	Ext. Function	1	1	1	0
ECAT processing unit and PDI error counters/PDI error code 0x030C:0x030E enabled	Ext. Function	1	1	1	0
User RAM disabled	Ext. Functions	1	0	0	0
1: POR Values, 0: VENDOR ID	Ext. Functions	0	0	0	0
EEPROM control by PDI enabled	PHY Layer	0	0	0	0
Lost link counters 0x0310:0x0313 enabled	PHY layer	1	1	1	0
MII management interface 0x0510 enabled	PHY layer	1	1	1	1
Enhanced link detection for MII enabled	PHY layer	1	1	1	1
Link detection and configuration for MII enabled	PHY layer	0	1	1	0
PDI support for MII management interface enabled	PHY layer	1	1	1	1
Automatic MII TX shift enabled	PHY layer	1	1	1	1
Extended RX Error counter registers 0x0314:0x0317 and 0x0320:0x0327 enabled	PHY layer	0	0	0	0
RUN LED enabled	LEDs	1	1	1	1

Chip Feature / Description	Domain	TMC8460	TMC8461	TMC8462	TMC8670
Link/activity LEDs enabled	LEDs	1	1	1	1
Port error LEDs enabled	LEDs	0	0	0	0
RUN/ERR LED override registers 0x0138:0x0139 enabled	LEDs	0	1	1	1
Configurable SPI PDI modes enabled	PDI	1	1	1	1
Digital IO output register 0x0F00:0x0F03 disabled	PDI	0	0	0	0
PDI user mode registers 0x0158/0x015C enabled	PDI	0	0	0	0
DC Latch unit enabled	DC	1	1	1	1
External DC speed counter diff direct control register 0x0938 enabled	DC	0	0	0	0
DC Sync unit enabled	DC	1	1	1	1
DC time loop control by PDI enabled	DC	0	0	0	0
DC with external local clock enabled	DC	0	0	0	0
EEPROM emulation enabled	EEPROM	0	0	0	0
Removable PDI (socket communication) enabled	EEPROM	0	0	0	0
EEPROM RAM/ROM instead of I2C/emulation enabled	EEPROM	0	0	0	0
Parameter loading to 0x0580 enabled	EEPROM	1	1	1	1
EEPROM streaming support enabled	EEPROM	0	0	0	0
8 Byte EEPROM read data enabled	EEPROM	1	0	0	0
Configurable EEPROM SIZE enabled	EEPROM	1	1	1	1
Extended ESC configuration register 0x0142:0x0143 (EEPROM word 5) enabled	EEPROM	0	0	0	0

Table 7: Available EtherCAT Chip Features (0 = not available/disabled, 1 = available/enabled)

6.3 EtherCAT Register Overview

TMC8462A has an address space of 20 KByte. The first block of 4KByte (0x0000:0x0FFF) is reserved for the standard ESC- and EtherCAT-relevant configuration and status registers. The Process Data RAM (PDRAM) starts at address 0x1000. TMC8462A has a Process Data RAM of 16 Kbyte.

Address	Length (Byte)	Description
		ESC Information
0x0000	1	Type
0x0001	1	Revision
0x0002:0x0003	2	Build
0x0004	1	FMMUs supported
0x0005	1	SyncManagers supported
0x0006	1	RAM Size
0x0007	1	Port Descriptor
0x0008:0x0009	2	ESC Features supported

		Station Address
0x0010:0x0011	2	Configured Station Address
0x0012:0x0013	2	Configured Station Alias

		Write Protection
0x0020	1	Write Register Enable
0x0021	1	Write Register Protection
0x0030	1	ESC Write Enable
0x0031	1	ESC Write Protection

		Data Link Layer
0x0040	1	ESC Reset ECAT
0x0041	1	ESC Reset PDI
0x0100:0x0103	4	ESC DL Control
0x0108:0x0109	2	Physical Read/Write Offset
0x0110:0x0111	2	ESC DL Status

Address	Length (Byte)	Description
		Application Layer
0x0120:0x0121	2	AL Control
0x0130:0x0131	2	AL Status
0x0134:0x0135	2	AL Status Code
0x0138	1	RUN LED Override
0x0139	1	ERR LED Override

		PDI
0x0140	1	PDI Control
0x0141	1	ESC Configuration
0x014E:0x014F	1	PDI Information
0x0150	4	PDI SPI Slave Configuration
0x0151	4	SYNC/LATCH PDI Configuration
0x0152:0x0153	4	Extended PDI SPI Slave Configuration

		Interrupts
0x0200:0x0201	2	ECAT Event Mask
0x0204:0x0207	4	AL Event Mask
0x0210:0x0211	2	ECAT Event Request
0x0220:0x0223	4	AL Event Request

		Error Counters
0x0300:0x0307	4x2	RX Error Counter[3:0]
0x0308:0x030B	4x1	Forward RX Error Counter[3:0]
0x030C	1	ECAT Processing Unit Error Counter
0x030D	1	PDI Error Counter
0x030E	1	PDI Error Code
0x0310:0x0313	4x1	Lost Link Counter[3:0]

Address	Length (Byte)	Description
		Watchdogs
0x0400:0x0401	2	Watchdog Divider
0x0410:0x0411	2	Watchdog Time PDI
0x0420:0x0421	2	Watchdog Time Process Data
0x0440:0x0441	2	Watchdog Status Process Data
0x0442	1	Watchdog Counter Process Data
0x0443	1	Watchdog Counter PDI

		SII EEPROM Interface
0x0500	1	EEPROM Configuration
0x0501	1	EEPROM PDI Access State
0x0502:0x0503	2	EEPROM Control/Status
0x0504:0x0507	4	EEPROM Address
0x0508:0x050F	4/8	EEPROM Data

		MII Management Interface
0x0510:0x0511	2	MII Management Control/Status
0x0512	1	PHY Address
0x0513	1	PHY Register Address
0x0514:0x0515	2	PHY Data
0x0516	1	MII Management ECAT Access State
0x0517	1	MII Management PDI Access State
0x0518:0x051B	4	PHY Port Status

0x0580:0x05FF	128	ESC Parameter RAM
0x0580:0x05FF	128 max.	TMC8xxx MFC IO Block Configuration

Address	Length (Byte)	Description
0x0600:0x06FF	16x16	FMMU[15:0]
+0x0:0x3	4	Logical Start Address
+0x4:0x5	2	Length
+0x6	1	Logical Start bit
+0x7	1	Logical Stop bit
+0x8:0x9	2	Physical Start Address
+0xA	1	Physical Start bit
+0xB	1	Type
+0xC	1	Activate
+0xD:0xF	3	Reserved

0x0800:0x087F	16x8	SyncManager[15:0]
+0x0:0x1	2	Physical Start Address
+0x2:0x3	2	Length
+0x4	1	Control Register
+0x5	1	Status Register
+0x6	1	Activate
+0x7	1	PDI Control

0x0900:0x09FF		Distributed Clocks (DC)
		DC Receive Times
0x0900:0x0903	4	Receive Time Port 0
0x0904:0x0907	4	Receive Time Port 1
0x0908:0x090B	4	Receive Time Port 2
0x090C:0x090F	4	Receive Time Port 3

Address	Length (Byte)	Description
		DC Time Loop Control Unit
0x0910:0x0917	4/8	System Time
0x0918:0x091F	4/8	Receive Time ECAT Processing Unit
0x0920:0x0927	4/8	System Time Offset
0x0928:0x092B	4	System Time Delay
0x092C:0x092F	4	System Time Difference
0x0930:0x0931	2	Speed Counter Start
0x0932:0x0933	2	Speed Counter Diff
0x0934	1	System Time Difference Filter Depth
0x0935	1	Speed Counter Filter Depth

		DC Cyclic Unit Control
0x0980	1	Cyclic Unit Control

		DC SYNC Out Unit
0x0981	1	Activation
0x0982:0x0983	2	Pulse Length of SYNC signals
0x0984	1	Activation Status
0x098E	1	SYNC0 Status
0x098F	1	SYNC1 Status
0x0990:0x0997	4/8	Start Time Cyclic Operation / Next SYNC0 Pulse
0x0998:0x099F	4/8	Next SYNC1 Pulse
0x09A0:0x09A3	4	SYNC0 Cycle Time
0x09A4:0x09A7	4	SYNC1 Cycle Time

Address	Length (Byte)	Description
		DC LATCH In Unit
0x09A8	1	Latch0 Control
0x09A9	1	Latch1 Control
0x09AE	1	Latch0 Status
0x09AF	1	Latch1 Status
0x09B0:0x09B7	4/8	Latch0 Time Positive Edge
0x09B8:0x09BF	4/8	Latch0 Time Negative Edge
0x09C0:0x09C7	4/8	Latch1 Time Positive Edge
0x09C8:0x09CF	4/8	Latch1 Time Negative Edge
		DC SyncManager Event Times
0x09F0:0x09F3	4	EtherCAT Buffer Change Event Time
0x09F8:0x09FB	4	PDI Buffer Start Event Time
0x09FC:0x09FF	4	PDI Buffer Change Event Time
0x0E00:0x0EFF	256	ESC Specific
0x0E00:0x0E07	8	Product ID
0x0E08:0x0E0F	8	Vendor ID
0x0F80:0x0FFF	128	User RAM
0x0F80:0x0FFF	20	reserved
		Process Data RAM
0x1000:0xFFFF	1-60KB	Process Data RAM

Table 8: TMC8462A EtherCAT Registers

For Registers longer than one byte, the LSB has the lowest and MSB the highest address.

6.4 EtherCAT Register Set

6.4.1 ESC Information

6.4.1.1 Type (0x0000)

Bit	Description	ECAT	PDI	Reset Value
7:0	Type of EtherCAT controller	r/-	r/-	TMC8460: 0xD0 TMC8461: 0xD0 TMC8462: 0xD0 TMC8670: 0xD0

Table 9: Register 0x0000 (Type)

6.4.1.2 Revision (0x0001)

Bit	Description	ECAT	PDI	Reset Value
7:0	Revision of EtherCAT controller	r/-	r/-	TMC8460: 0x60 TMC8461: 0x61 TMC8462: 0x61 TMC8670: 0x70

Table 10: Register 0x0001 (Revision)

6.4.1.3 Build (0x0002:0x0003)

Bit	Description	ECAT	PDI	Reset Value
15:0	Actual build of EtherCAT controller, minor version, maintenance version	r/-	r/-	TMC8460: 0x10 TMC8461: 0x11 TMC8462: 0x11 TMC8670: 0x10

Table 11: Register 0x0002 (Build)

6.4.1.4 FMMUs supported (0x0004)

Bit	Description	ECAT	PDI	Reset Value
7:0	Number of supported FMMU channels (or entities) of the EtherCAT slave controller.	r/-	r/-	TMC8460: 6 TMC8461: 8 TMC8462: 8 TMC8670: 4

*Table 12: Register 0x0004 (FMMUs)***6.4.1.5 SyncManagers supported (0x0005)**

Bit	Description	ECAT	PDI	Reset Value
7:0	Number of supported SyncManager channels (or entities) of the EtherCAT Slave Controller	r/-	r/-	TMC8460: 6 TMC8461: 8 TMC8462: 8 TMC8670: 4

*Table 13: Register 0x0005 (SMs)***6.4.1.6 RAM Size (0x0006)**

Bit	Description	ECAT	PDI	Reset Value
7:0	Process Data RAM size supported by the EtherCAT Slave Controller in KByte	r/-	r/-	TMC8460: 16 TMC8461: 16 TMC8462: 16 TMC8670: 4

Table 14: Register 0x0006 (RAM Size)

6.4.1.7 Port Descriptor (0x0007)

Bit	Description	ECAT	PDI	Reset Value
	Port configuration: 00: Not implemented 01: Not configured (SII EEPROM) 10: EBUS 11: MII RMII RGMII			
1:0	Port 0	r/-	r/-	TMC8460: 11 TMC8461: 11 TMC8462: 11 TMC8670: 11
3:2	Port 1	r/-	r/-	TMC8460: 11 TMC8461: 11 TMC8462: 11 TMC8670: 11
7:4	not supported	r/-	r/-	0

Table 15: Register 0x0007 (Port Descriptor)

6.4.1.8 ESC Features supported (0x0008:0x0009)

Bit	Description	ECAT	PDI	Reset Value
0	FMMU Operation: 0: Bit oriented 1: Byte oriented	r/-	r/-	
1	Reserved	r/-	r/-	
2	Distributed Clocks: 0: Not available 1: Available	r/-	r/-	
3	Distributed Clocks (width): 0: 32 bit 1: 64 bit	r/-	r/-	
4	Low Jitter EBUS: 0: Not available, standard jitter 1: Available, jitter minimized	r/-	r/-	0
5	Enhanced Link Detection EBUS: 0: Not available 1: Available	r/-	r/-	0
6	Enhanced Link Detection MII 0: Not available 1: Available	r/-	r/-	

Bit	Description	ECAT	PDI	Reset Value
7	Separate Handling of FCS Errors: 0: Not supported 1: Supported, frames with wrong FCS and additional nibble will be counted separately in Forwarded RX Error Counter	r/-	r/-	
8	Enhanced DCSYNC Activation 0: Not available 1: Available NOTE: This feature refers to registers 0x981.(7:3), 0x0984	r/-	r/-	
9	EtherCAT LRW command support: 0: Supported 1: Not Supported	r/-	r/-	
10	EtherCAT read/write command support 0: Supported 1: Not Supported	r/-	r/-	
11	Fixed FMMU/SyncManager configuration 0: Variable configuration 1: Fixed configuration (refer to documentation of supporting ESCs)	r/-	r/-	
15:12	Reserved	r/-	r/-	

Table 16: Register 0x0008:0x0009 (ESC Features)

6.4.2 Station Address

6.4.2.1 Configured Station Address (0x0010:0x0011)

Bit	Description	ECAT	PDI	Reset Value
15:0	Address used for node addressing (FPxx commands)	r/w	r/-	

Table 17: Register 0x0010:0x0011 (Station Addr)

6.4.2.2 Configured Station Alias (0x0012:0x0013)

Bit	Description	ECAT	PDI	Reset Value
15:0	Alias Address used for node addressing (FPxx commands) The use of this alias is activated by Register DL Control Bit 24 (0x0100.24/0x0103.0) NOTE: EEPROM value is only taken over at first EEPROM load after power-on reset.	r/-	r/w	

Table 18: Register 0x0012:0x0013 (Station Alias)

6.4.3 Write Protection

6.4.3.1 Write Register Enable (0x0020)

Bit	Description	ECAT	PDI	Reset Value
0	If write register protection is enabled, this register has to be written in the same Ethernet frame (value does not care) before other writes to this station are allowed. Write protection is still active after this frame (if Write Register Protection register is not changed).	r/w	r/-	
7:1	Reserved, write 0	r/-	r/-	

Table 19: Register 0x0020 (Write Register Enable)

6.4.3.2 Write Register Protection (0x0021)

Bit	Description	ECAT	PDI	Reset Value
0	Write register protection: 0: Protection disabled 1: Protection enabled Registers 0x0000–0x0137, 0x013A–0x0F0F are write protected, except for 0x0030	r/w	r/-	
7:1	Reserved, write 0	r/-	r/-	

Table 20: Register 0x0021 (Write Register Prot.)

6.4.3.3 ESC Write Enable (0x0030)

Bit	Description	ECAT	PDI	Reset Value
0	If ESC write protection is enabled, this register has to be written in the same Ethernet frame (value does not care) before other writes to this station are allowed. ESC write protection is still active after this frame (if ESC Write Protection register is not changed).	r/w	r/-	
7:1	Reserved, write 0	r/-	r/-	

Table 21: Register 0x0030 (ESC Write Enable)

6.4.3.4 ESC Write Protection (0x0031)

Bit	Description	ECAT	PDI	Reset Value
15:0	Write protect: 0: Protection disabled 1: Protection enabled All areas are write protected, except for 0x0030.	r/w	r/-	
7:1	Reserved, write 0	r/-	r/-	

Table 22: Register 0x0031 (ESC Write Prot.)

6.4.4 Data Link Layer

6.4.4.1 ESC Reset ECAT (0x0040)

Bit	Description	ECAT	PDI	Reset Value
Write				
7:0	Reset is asserted after writing 0x52 ('R'), 0x45 ('E'), 0x53 ('S') in this register with 3 consecutive frames.	r/w	r/-	
Read				
1:0	Progress of the reset procedure: 01: after writing 0x52 10: after writing 0x45 (if 0x52 was written) 00: else	r/w	r/-	
7:2	Reserved, write 0	r/-	r/-	

Table 23: Register 0x0040 (ESC Reset ECAT)

6.4.4.2 ESC Reset PDI (0x0041)

Bit	Description	ECAT	PDI	Reset Value
Write				
7:0	Reset is asserted after writing 0x52 ('R'), 0x45 ('E'), 0x53 ('S') in this register with 3 consecutive commands.	r/-	r/w	
Read				
1:0	Progress of the reset procedure: 01: after writing 0x52 10: after writing 0x45 (if 0x52 was written) 00: else	r/-	r/w	
7:2	Reserved, write 0	r/-	r/-	

Table 24: Register 0x0041 (ESC Reset PDI)

6.4.4.3 ESC DL Control (0x0100:0x0103)

Bit	Description	ECAT	PDI	Reset Value
0	Forwarding rule: 0: EtherCAT frames are processed, Non-EtherCAT frames are forwarded without processing 1: EtherCAT frames are processed, Non-EtherCAT frames are destroyed The source MAC address is changed for every frame (SOURCE_MAC[1] is set to 1 - locally administered address) regardless of the forwarding rule.	r/-	r/-	
1	Temporary use of settings in Register 0x101: 0: permanent use 1: use for about 1 second, then revert to previous settings	r/-	r/-	
7:2	Reserved, write 0	r/-	r/-	
9:8	Loop Port 0: 00: Auto 01: Auto Close 10: Open 11: Closed Note Loop open means sending/receiving over this port is enabled, loop closed means sending/receiving is disabled and frames are forwarded to the next open port internally. Auto: loop closed at link down, opened at link up Auto Close: loop closed at link down, opened with writing 01 again after link up (or receiving a valid Ethernet frame at the closed port) Open: loop open regardless of link state Closed: loop closed regardless of link state	r/w*	r/-	
11:10	Loop Port 1: 00: Auto 01: Auto Close 10: Open 11: Closed	r/w*	r/-	
13:12	Loop Port 2: 00: Auto 01: Auto Close 10: Open 11: Closed	r/w*	r/-	
15:14	Loop Port 3: 00: Auto 01: Auto Close 10: Open 11: Closed	r/w*	r/-	

Bit	Description	ECAT	PDI	Reset Value
18:16	RX FIFO Size (ESC delays start of forwarding until FIFO is at least half full). RX FIFO Size/RX delay reduction** : Value (for MII): 0: -40 ns 1: -40 ns 2: -40 ns 3: -40 ns 4: no change 5: no change 6: no change 7: default default NOTE: EEPROM value is only taken over at first EEPROM load after power-on or reset	r/w	r/-	
19	EBUS Low Jitter: 0: Normal jitter / 1: Reduced jitter	r/w	r/-	0
21:20	Reserved, write 0	r/w	r/-	
22	EBUS remote link down signaling time: 0: Default (≈ 660 ms) 1: Reduced (≈ 80 μ s)	r/w	r/-	0
23	Reserved, write 0	r/w	r/-	
24	Station alias: 0: Ignore Station Alias 1: Alias can be used for all configured address command types (FPRD, FPWR, ...)	r/w	r/-	
31:25	Reserved, write 0	r/-	r/-	

Table 25: Register 0x0100:0x0103 (DL Control)

* Loop configuration changes are delayed until end of currently received or transmitted frame at the port.
** The possibility of RX FIFO Size reduction depends on the clock source accuracy of the ESC and of every connected EtherCAT/Ethernet devices (master, slave, etc.). RX FIFO Size of 7 is sufficient for 100ppm accuracy, FIFO Size 0 is possible with 25ppm accuracy (frame size of 1518/1522 Byte).

6.4.4.4 Physical Read/Write Offset (0x0108:0x0109)

Bit	Description	ECAT	PDI	Reset Value
15:0	Offset of R/W Commands (FPRW, APRW) between Read address and Write address. RD_ADR = ADR and WR_ADR = ADR + R/W-Offset 0	r/w	r/-	

Table 26: Register 0x0108:0x0109 (R/W Offset)

6.4.4.5 ESC DL Status (0x0110:0x0111)

Bit	Description	ECAT	PDI	Reset Value
0	PDI operational/EEPROM loaded correctly: 0: EEPROM not loaded, PDI not operational (no access to Process Data RAM) 1: EEPROM loaded correctly, PDI operational (access to Process Data RAM)	r*/-	r/-	
1	PDI Watchdog Status: 0: Watchdog expired 1: Watchdog reloaded	r*/-	r/-	
2	Enhanced Link detection: 0: Deactivated for all ports 1: Activated for at least one port NOTE: EEPROM value is only taken over at first EEPROM load after power-on or reset	r*/-	r/-	
3	Reserved	r*/-	r/-	
4	Physical link on Port 0: 0: No link 1: Link detected	r*/-	r/-	
5	Physical link on Port 1: 0: No link 1: Link detected	r*/-	r/-	
6	Physical link on Port 2: 0: No link 1: Link detected	r*/-	r/-	
7	Physical link on Port 3: 0: No link 1: Link detected	r*/-	r/-	
8	Loop Port 0: 0: Open 1: Closed	r*/-	r/-	
9	Communication on Port 0: 0: No stable communication 1: Communication established	r*/-	r/-	
10	Loop Port 1: 0: Open 1: Closed	r*/-	r/-	
11	Communication on Port 1: 0: No stable communication 1: Communication established	r*/-	r/-	
12	Loop Port 2: 0: Open 1: Closed	r*/-	r/-	
13	Communication on Port 2: 0: No stable communication 1: Communication established	r*/-	r/-	

Bit	Description	ECAT	PDI	Reset Value
14	Loop Port 3: 0: Open 1: Closed	r*/-	r/-	
15	Communication on Port 3: 0: No stable communication 1: Communication established	r*/-	r/-	

Table 27: Register 0x0110:0x0111 (DL Status)

* Reading DL Status register from ECAT clears ECAT Event Request 0x0210 . 2.

Register 0x0111	Port 3	Port2	Port1	Port 0
0x55	No link, closed	No link, closed	No link, closed	No link, closed
0x56	No link, closed	No link, closed	No link, closed	Link, open
0x59	No link, closed	No link, closed	Link, open	No link, closed
0x5A	No link, closed	No link, closed	Link, open	Link, open
0x65	No link, closed	Link, open	No link, closed	No link, closed
0x66	No link, closed	Link, open	No link, closed	Link, open
0x69	No link, closed	Link, open	Link, open	No link, closed
0x6A	No link, closed	Link, open	Link, open	Link, open
0x95	Link, open	No link, closed	No link, closed	No link, closed
0x96	Link, open	No link, closed	No link, closed	Link, open
0x99	Link, open	No link, closed	Link, open	No link, closed
0x9A	Link, open	No link, closed	Link, open	Link, open
0xA5	Link, open	Link, open	No link, closed	No link, closed
0xA6	Link, open	Link, open	No link, closed	Link, open
0xA9	Link, open	Link, open	Link, open	No link, closed
0xAA	Link, open	Link, open	Link, open	Link, open
0xD5	Link, closed	No link, closed	No link, closed	No link, closed
0xD6	Link, closed	No link, closed	No link, closed	Link, open
0xD9	Link, closed	No link, closed	Link, open	No link, closed
0xDA	Link, closed	No link, closed	Link, open	Link, open

Table 28: Decoding port state in ESC DL Status register 0x0111 (typical modes only)

6.4.5 Application Layer

6.4.5.1 AL Control (0x0120:0x0121)

Bit	Description	ECAT	PDI	Reset Value
3:0	Initiate State Transition of the Device State Machine: 1: Request Init State 3: Request Bootstrap State 2: Request Pre-Operational State 4: Request Safe-Operational State 8: Request Operational State	r/(w)	r/ (wack)*	
4	Error Ind Ack: 0: No Ack of Error Ind in AL status register 1: Ack of Error Ind in AL status register	r/(w)	r/ (wack)*	
4	Device Identification: 0: No request 1: Device Identification request	r/(w)	r/ (wack)*	
15:6	Reserved, write 0	r/(w)	r/ (wack)*	

Table 29: Register 0x0120:0x0121 (AL Cntrl)

Note

AL Control register behaves like a mailbox if Device Emulation is off (0x0140.8=0): The PDI has to read/write* the AL Control register after ECAT has written it. Otherwise ECAT cannot write again to the AL Control register. After Reset, AL Control register can be written by ECAT. (Regarding mailbox functionality, both registers 0x0120 and 0x0121 are equivalent, e.g. reading 0x0121 is sufficient to make this register writeable again.)

If Device Emulation is on, the AL Control register can always be written, its content is copied to the AL Status register.

* PDI register function acknowledge by Write command is disabled: Reading AL Control from PDI clears AL Event Request 0x0220.0. Writing to this register from PDI is not possible.

PDI register function acknowledge by Write command is enabled: Writing AL Control from PDI clears AL Event Request 0x0220.0. Writing to this register from PDI is possible; write value is ignored (write 0).

6.4.5.2 AL Status (0x0130:0x0131)

Bit	Description	ECAT	PDI	Reset Value
3:0	Actual State of the Device State Machine: 1: Init State 3: Request Bootstrap State 2: Pre-Operational State 4: Safe-Operational State 8: Operational State	r*/-	r/(w)	
4	Error Ind: 0: Device is in State as requested or Flag cleared by command 1: Device has not entered requested State or changed State as result of a local action	r*/-	r/(w)	
5	Device Identification: 0: Device Identification not valid 1: Device Identification loaded	r*/-	r/(w)	
15:6	Reserved, write 0	r*/-	r/(w)	

Table 30: Register 0x0130:0x0131 (AL Status)

Note AL Status register is only writable from PDI if Device Emulation is off (0x0140.8=0), otherwise AL Status register will reflect AL Control register values.

* Reading AL Status from ECAT clears ECAT Event Request 0x0210.3.

6.4.5.3 AL Status Code (0x0134:0x0135)

Bit	Description	ECAT	PDI	Reset Value
15:0	AL Status Code	r/-	r/w	

Table 31: Register 0x0134:0x0135 (AL Status Code)

6.4.5.4 RUN LED Override (0x0138)

Bit	Description	ECAT	PDI	Reset Value
3:0	LED code: (FSM State) 0x0: Off (1-Init) 0x1-0xC: Flash 1x - 12x (4-SafeOp 1x) 0xD: Blinking (2-PreOp) 0xE: Flickering (3-Bootstrap) 0xF: On	r/w	r/w	
4	Enable Override: 0: Override disabled 1: Override enabled	r/w	r/w	
7:5	Reserved, write 0	r/w	r/w	

Table 32: Register 0x0138 (RUN LED Override)

Note

Changes to AL Status register (0x0130) with valid values will disable RUN LED Override (0x0138.4=0). The value read in this register always reflects current LED output.

6.4.5.5 ERR LED Override (0x0139)

Bit	Description	ECAT	PDI	Reset Value
3:0	LED code: 0x0: Off 0x1-0xC: Flash 1x - 12x 0xD: Blinking 0xE: Flickering 0xF: On	r/w	r/w	
4	Enable Override: 0: Override disabled 1: Override enabled	r/w	r/w	
7:5	Reserved, write 0	r/w	r/w	

Table 33: Register 0x0139 (ERR LED Override)

Note

New error conditions will disable ERR LED Override (0x0139.4=0). The value read in this register always reflects current LED output.

6.4.6 PDI

6.4.6.1 PDI Control (0x0140)

Bit	Description	ECAT	PDI	Reset Value
7:0	Process data interface: 0x00: Interface deactivated (no PDI) ... 0x05: SPI Slave ... 0x80: On-chip bus Others: Reserved	r/-	r/-	TMC8460, TMC8461, TMC8462, TMC8670: 0x00 later EEPROM ADR 0x0000 only SPI Slave (0x05) is supported in the hard- ware

Table 34: Register 0x0140 (PDI Control)

6.4.6.2 ESC Configuration (0x0141)

Bit	Description	ECAT	PDI	Reset Value
0	Device emulation (control of AL status): 0: AL status register has to be set by PDI 1: AL status register will be set to value written to AL control register	r/w	r/-	
1	Enhanced Link detection all ports: 0: disabled (if bits [7:4]=0) 1: enabled at all ports (overrides bits [7:4])	r/-	r/-	
2	Distributed Clocks SYNC Out Unit: 0: disabled (power saving) / 1: enabled	r/-	r/-	
3	Distributed Clocks Latch In Unit: 0: disabled (power saving) / 1: enabled	r/-	r/-	
4	Enhanced Link port 0: 0: disabled (if bit 1=0) / 1: enabled	r/-	r/-	
5	Enhanced Link port 1: 0: disabled (if bit 1=0) / 1: enabled	r/-	r/-	
6	Enhanced Link port 2: 0: disabled (if bit 1=0) / 1: enabled	r/-	r/-	
7	Enhanced Link port 3: 0: disabled (if bit 1=0) / 1: enabled	r/-	r/-	

Table 35: Register 0x0141 (ESC Config)

6.4.6.3 PDI Information (0x014E:0x014F)

Bit	Description	ECAT	PDI	Reset Value
0	PDI register function acknowledge by write: 0: Disabled 1: Enabled	r/w	r/-	Depends on configuration
1	PDI configured: 0: PDI not configured 1: PDI configured (EEPROM loaded)	r/w	r/-	0
2	PDI active: 0: PDI not active 1: PDI active	r/w	r/-	0
3	PDI configuration invalid: 0: PDI configuration ok 1: PDI configuration invalid	r/w	r/-	0
7:4	Reserved	r/w	r/-	0

Table 36: Register 0x014E (PDI Information)

6.4.6.4 PDI SPI Slave Configuration (0x0150)

The PDI configuration register 0x0150 and the extended PDI configuration registers 0x0152:0x0153 depend on the selected PDI. The Sync/Latch[1:0] PDI configuration register 0x0151 is independent of the selected PDI. The TMC8460, TMC8461, TMC8462, and TMC8670 devices support SPI Slave PDI only.

Bit	Description	ECAT	PDI	Reset Value
1:0	SPI mode: 00: SPI mode 0 01: SPI mode 1 10: SPI mode 2 11: SPI mode 3 NOTE: SPI mode 3 is recommended for Slave Sample Code NOTE: SPI status flag is not available in SPI modes 0 and 2 with normal data out sample.	r/-	r/-	
3:2	SPI_IRQ output driver/polarity: 00: Push-Pull active low 01: Open Drain (active low) 10: Push-Pull active high 11: Open Source (active high)	r/-	r/-	
4	SPI_CS_NL polarity: 0: Active low 1: Active high	r/-	r/-	
5	Data Out sample mode: 0: Normal sample (SPI_MISO and SPI_MOSI are sampled at the same SPI_CLK edge) 1: Late sample (SPI_MISO and SPI_MOSI are sampled at different SPI_CLK edges)	r/-	r/-	
7:6	Reserved, set EEPROM value 0	r/-	r/-	

Table 37: Register 0x0150 (PDI SPI CFG)

6.4.6.5 SYNC/LATCH Configuration (0x0151)

Bit	Description	ECAT	PDI	Reset Value
1:0	SYNC0 output driver/polarity: 00: Push-Pull active low 01: Open Drain (active low) 10: Push-Pull active high 11: Open Source (active high)	r/-	r/-	TMC8461: 10 TMC8462: 10
2	SYNC0/LATCH0 configuration: 0: LATCH0 Input 1: SYNC0 Output	r/-	r/-	TMC8461: 1 TMC8462: 1
3	SYNC0 mapped to AL Event Request register 0x0220.2: 0: Disabled 1: Enabled	r/-	r/-	TMC8461, TMC8462: depends on configuration

Bit	Description	ECAT	PDI	Reset Value
5:4	SYNC1 output driver/polarity: 00: Push-Pull active low 01: Open Drain (active low) 10: Push-Pull active high 11: Open Source (active high)	r/-	r/-	TMC8461: 10 TMC8462: 10
6	SYNC1/LATCH1 configuration*: 0: LATCH1 input 1: SYNC1 output	r/-	r/-	TMC8461: 1 TMC8462: 1
7	SYNC1 mapped to AL Event Request register 0x0220.3: 0: Disabled 1: Enabled	r/-	r/-	TMC8461, TMC8462: depends on configuration

Table 38: Register 0x0151 (SYNC/LATCH CFG)

6.4.6.6 PDI SPI Slave Extended Configuration (0x0152:0x0153)

Bit	Description	ECAT	PDI	Reset Value
15:0	Reserved, set EEPROM value 0	r/-	r/-	TMC8461: 0 TMC8462: 0

Table 39: Register 0x0152:0x0153 (PDI SPI extCFG)

6.4.7 Interrupts

6.4.7.1 ECAT Event Mask (0x0200:0x0201)

Bit	Description	ECAT	PDI	Reset Value
15:0	ECAT Event masking of the ECAT Event Request Events for mapping into ECAT event field of EtherCAT frames: 0: Corresponding ECAT Event Request register bit is not mapped 1: Corresponding ECAT Event Request register bit is mapped	r/w	r/-	

Table 40: Register 0x0200:0x0201 (ECAT Event M.)

6.4.7.2 AL Event Mask (0x0204:0x0207)

Bit	Description	ECAT	PDI	Reset Value
31:0	AL Event masking of the AL Event Request register Events for mapping to PDI IRQ signal: 0: Corresponding AL Event Request register bit is not mapped 1: Corresponding AL Event Request register bit is mapped	r/-	r/w	

Table 41: Register 0x0204:0x0207 (AL Event Mask)

6.4.7.3 ECAT Event Request (0x0210:0x0211)

Bit	Description	ECAT	PDI	Reset Value
0	DC Latch event: 0: No change on DC Latch Inputs 1: At least one change on DC Latch Inputs (Bit is cleared by reading DC Latch event times from ECAT for ECAT controlled Latch Units, so that Latch 0/1 Status 0x09AE:0x09AF indicates no event)	r/-	r/-	
1	Reserved	r/-	r/-	
2	DL Status event: 0: No change in DL Status 1: DL Status change (Bit is cleared by reading out DL Status 0x0110:0x0111 from ECAT)	r/-	r/-	

Bit	Description	ECAT	PDI	Reset Value
3	AL Status event: 0: No change in AL Status 1: AL Status change (Bit is cleared by reading out AL Status 0x0130:0x0131 from ECAT)	r/-	r/-	
4	Mirrors values of each SyncManager Status: 0: No Sync Channel 0 event 1: Sync Channel 0 event pending	r/w	r/-	
5	0: No Sync Channel 1 event 1: Sync Channel 1 event pending			
...	...			
	0: No Sync Channel 7 event 1: Sync Channel 7 event pending			
15:12	Reserved	r/-	r/-	

Table 42: Register 0x0210:0x0211 (ECAT Event R.)

6.4.7.4 AL Event Request (0x0220:0x0223)

Bit	Description	ECAT	PDI	Reset Value
0	AL Control event: 0: No AL Control Register change 1: AL Control Register has been written ¹ (Bit is cleared by reading AL Control register 0x0120:0x0121 from PDI)	r/-	r/-	
1	DC Latch event: 0: No change on DC Latch Inputs 1: At least one change on DC Latch Inputs (Bit is cleared by reading DC Latch event times from PDI, so that Latch 0/1 Status 0x09AE:0x09AF indicates no event. Available if Latch Unit is PDI controlled)	r/-	r/-	
2	State of DC SYNC0 (if register 0x0151.3=1): (Bit is cleared by reading SYNC0 status 0x098E from PDI, use only in Acknowledge mode)	r/-	r/-	
3	State of DC SYNC1 (if register 0x0151.7=1): (Bit is cleared by reading of SYNC1 status 0x098F from PDI, use only in Acknowledge mode)	r/-	r/-	

¹ AL control event is only generated if PDI emulation is turned off (PDI Control register 0x0140.8=0)

Bit	Description	ECAT	PDI	Reset Value
4	SyncManager activation register (SyncManager register offset 0x6) changed: 0: No change in any SyncManager 1: At least one SyncManager changed (Bit is cleared by reading SyncManager Activation registers 0x0806 etc. from PDI)	r/-	r/-	
5	EEPROM Emulation: 0: No command pending 1: EEPROM command pending (Bit is cleared by acknowledging the command in EEPROM command register 0x0502 from PDI)	r/-	r/-	
6	Watchdog Process Data: 0: Has not expired 1: Has expired (Bit is cleared by reading Watchdog Status Process Data 0x0440 from PDI)	r/-	r/-	
7	Reserved	r/-	r/-	
8 9 ... 23	SyncManager interrupts (SyncManager register offset 0x5, bit [0] or [1]): 0: No SyncManager 0 interrupt 1: SyncManager 0 interrupt pending 0: No SyncManager 1 interrupt 1: SyncManager 1 interrupt pending ... 0: No SyncManager 15 interrupt 1: SyncManager 15 interrupt pending	r/-	r/-	
31:24	Reserved	r/-	r/-	

Table 43: Register 0x0220:0x0223 (AL Event R.)

6.4.8 Error Counters

Errors are only counted if the corresponding port is enabled.

6.4.8.1 RX Error Counter[3:0] (0x0300:0x0307)

Bit	Description	ECAT	PDI	Reset Value
7:0	Invalid frame counter of Port y (counting is stopped when 0xFF is reached).	r/ w(clr)	r/-	
15:8	RX Error counter of Port y (counting is stopped when 0xFF is reached). This is coupled directly to RX ERR of MII interface.	r/ w(clr)	r/-	

Table 44: Register 0x0300:0x0307 (RX Err Cnt)

6.4.8.2 Forward RX Error Counter[3:0] (0x0308:0x030B)

Bit	Description	ECAT	PDI	Reset Value
7:0	Forwarded error counter of Port y (counting is stopped when 0xFF is reached).	r/ w(clr)	r/-	

Table 45: Register 0x0308:0x030B (FW RX Err Cnt)

Note

Error Counters 0x0300-0x030B are cleared if one of the RX Error counters 0x0300-0x030B is written. Write value is ignored (write 0).

6.4.8.3 ECAT Processing Unit Error Counter (0x030C)

Bit	Description	ECAT	PDI	Reset Value
7:0	ECAT Processing Unit error counter (counting is stopped when 0xFF is reached). Counts errors of frames passing the Processing Unit (e.g., FCS is wrong or datagram structure is wrong).	r/ w(clr)	r/-	

Table 46: Register 0x030C (Proc. Unit Err Cnt)

Note

Error Counter 0x030C is cleared if error counter 0x030C is written. Write value is ignored (write 0).

6.4.8.4 PDI Error Counter (0x030D)

Bit	Description	ECAT	PDI	Reset Value
7:0	PDI Error counter (counting is stopped when 0xFF is reached). Counts if a PDI access has an interface error.	r/ w(clr)	r/-	

Table 47: Register 0x030D (PDI Err Cnt)

Note Error Counter 0x030D and Error Code 0x030E are cleared if error counter 0x030D is written. Write value is ignored (write 0).

6.4.8.5 PDI Error Code (0x030E)

Bit	Description	ECAT	PDI	Reset Value
	SPI access which caused last PDI Error. Cleared if register 0x030D is written.	r/-	r/-	
2:0	Number of SPI clock cycles of whole access (modulo 8)	r/-	r/-	
3	Busy violation during read access	r/-	r/-	
4	Read termination missing	r/-	r/-	
5	Access continued after read termination byte	r/-	r/-	
7:6	SPI command CMD[2:1]	r/-	r/-	

Table 48: Register 0x030E (PDI Err Code)

Note Error Counter 0x030D and Error Code 0x030E are cleared if error counter 0x030D is written. Write value is ignored (write 0).

6.4.8.6 Lost Link Counter[3:0] (0x0310:0x0313)

Bit	Description	ECAT	PDI	Reset Value
7:0	Lost Link counter of Port y (counting is stopped when 0xff is reached). Counts only if port loop is Auto.	r/w(clr)	r/-	

Table 49: Register 0x0310:0x0313 (LL Counter)

Note Only lost links at open ports are counted. Lost Link Counters 0x0310-0x0313 are cleared if one of the Lost Link Counters 0x0310-0x0313 is written. Write value is ignored (write 0).

6.4.9 Watchdogs

6.4.9.1 Watchdog Divider (0x0400:0x0401)

Bit	Description	ECAT	PDI	Reset Value
15:0	Watchdog Time PDI: number or basic watchdog increments (Default value with Watchdog divider 100 μ s means 100ms Watchdog)	r/w	r/-	

Table 50: Register 0x0400:0x0401 (WD Divider)

6.4.9.2 Watchdog Time PDI (0x0410:0x0411)

Bit	Description	ECAT	PDI	Reset Value
15:0	Watchdog Time PDI: number or basic watchdog increments (Default value with Watchdog divider 100 μ s means 100ms Watchdog)	r/w	r/-	

Table 51: Register 0x0410:0x0411 (WD Time PDI)

Note

Watchdog is disabled if Watchdog time is set to 0x0000. Watchdog is restarted with every PDI access.

6.4.9.3 Watchdog Time Process Data (0x0420:0x0421)

Bit	Description	ECAT	PDI	Reset Value
15:0	Watchdog Time Process Data: number of basic watchdog increments (Default value with Watchdog divider 100 μ s means 100ms Watchdog)	r/w	r/-	

Table 52: Register 0x0420:0x0421 (WD Time PD)

Note

There is one Watchdog for all SyncManagers. Watchdog is disabled if Watchdog time is set to 0x0000. Watchdog is restarted with every write access to SyncManagers with Watchdog Trigger Enable Bit set.

6.4.9.4 Watchdog Status Process Data (0x0440:0x0441)

Bit	Description	ECAT	PDI	Reset Value
15:0	Watchdog Status of Process Data (triggered by SyncManagers) 0: Watchdog Process Data expired 1: Watchdog Process Data is active or disabled	r/-	r/ (w ack)*	
0	Reserved	r/-	r/ (w ack)*	

Table 53: Register 0x0440:0x0441 (WD Status PD)

* PDI register function acknowledge by Write command is disabled: Reading this register from PDI clears AL Event Request 0x0220.6. Writing to this register from PDI is not possible.
PDI register function acknowledge by Write command is enabled: Writing this register from PDI clears AL Event Request 0x0220.6. Writing to this register from PDI is possible; write value is ignored (write 0).

6.4.9.5 Watchdog Counter Process Data (0x0442)

Bit	Description	ECAT	PDI	Reset Value
7:0	Watchdog Counter Process Data (counting is stopped when 0xFF is reached). Counts if Process Data Watchdog expires.	r/ w(clr)	r/-	

Table 54: Register 0x0442 (WD Counter PD)

Note

Watchdog Counters 0x0442-0x0443 are cleared if one of the Watchdog Counters 0x0442-0x0443 is written. Write value is ignored (write 0).

6.4.9.6 Watchdog Counter PDI (0x0443)

Bit	Description	ECAT	PDI	Reset Value
7:0	Watchdog PDI counter (counting is stopped when 0xFF is reached). Counts if PDI Watchdog expires.	r/ w(clr)	r/-	

*Table 55: Register 0x0443 (WD Counter PDI)***Note**

Watchdog Counters 0x0442 & 0x0443 are cleared if one of the Watchdog Counters 0x0442 & 0x0443 is written. Write value is ignored (write 0).

6.4.10 SII EEPROM Interface

Address	Length (Byte)	Description
		SII EEPROM Interface
0x0500	1	EEPROM Configuration
0x0501	1	EEPROM PDI Access State
0x0502:0x0503	2	EEPROM Control/Status
0x0504:0x0507	4	EEPROM Address
0x0508:0x050F	4/8	EEPROM Data

Table 56: SII EEPROM Interface Register Overview

6.4.10.1 EEPROM Configuration (0x0500)

Bit	Description	ECAT	PDI	Reset Value
0	EEPROM control is offered to PDI: 0: no 1: yes (PDI has EEPROM control)	r/w	r/-	
1	Force ECAT access: 0: Do not change Bit 0x0501.0 1: Reset Bit 0x0501.0 to 0	r/w	r/-	
7:2	Reserved, write 0	r/w	r/-	

Table 57: Register 0x0500 (PROM Config)

6.4.10.2 EEPROM PDI Access State (0x0501)

Bit	Description	ECAT	PDI	Reset Value
0	Access to EEPROM: 0: PDI releases EEPROM access 1: PDI takes EEPROM access (PDI has EEPROM control)	r/-	r/(w)	
7:1	Reserved, write 0	r/-	r/-	

Table 58: Register 0x0501 (PROM PDI Access)

Note r/(w): write access is only possible if 0x0500.0=1 and 0x0500.1=0.

6.4.10.3 EEPROM Control/Status (0x0502:0x0503)

Bit	Description	ECAT	PDI	Reset Value
0	ECAT write enable* ² : 0: Write requests are disabled 1: Write requests are enabled This bit is always 1 if PDI has EEPROM control.	r/(w)	r/-	
4:1	Reserved, write 0	r/-	r/-	
5	EEPROM emulation: 0: Normal operation (I2C interface used) 1: PDI emulates EEPROM (I2C not used)	r/-	r/-	
6	Supported number of EEPROM read bytes: 0: 4 Bytes 1: 8 Bytes	r/-	r/-	
7	Selected EEPROM Algorithm: 0: 1 address byte (1KBit ... 16KBit EEPROMs) 1: 2 address bytes (32KBit ... 4 MBit EEPROMs)	r/-	r/- r/[w]	
10:8	Command register* ¹ : Write: Initiate command. Read: Currently executed command Commands: 000: No command/EEPROM idle (clear error bits) 001: Read 010: Write 100: Reload Others: Reserved/invalid commands (do not issue) EEPROM emulation only: after execution, PDI writes command value to indicate operation is ready.	r/(w)	r/(w) r/[w]	
11	Checksum Error at in ESC Configuration Area: 0: Checksum ok 1: Checksum error	r/-	r/-	
12	EEPROM loading status: 0: EEPROM loaded, device information ok 1: EEPROM not loaded, device information not available (EEPROM loading in progress or finished with a failure)	r/-	r/-	
13	Error Acknowledge/Command* ² : 0: No error 1: Missing EEPROM acknowledge or invalid command EEPROM emulation only: PDI writes 1 if a temporary failure has occurred.	r/-	r/- r/[w]	

Bit	Description	ECAT	PDI	Reset Value
14	Error Write Enable*2: 0: No error 1: Write Command without Write enable	r/-	r/-	
15	Busy: 0: EEPROM Interface is idle 1: EEPROM Interface is busy	r/-	r/-	

Table 59: Register 0x0502:0x0503 (PROM Cntrl)

Note r/(w): write access depends upon the assignment of the EEPROM interface (ECAT/PDI). Write access is generally blocked if EEPROM interface is busy (0x0502.15=1).

Note r/[w]: EEPROM emulation only: write access is possible if EEPROM interface is busy (0x0502.15=1). PDI acknowledges pending commands by writing a 1 into the corresponding command register bits (0x0502.10:8). Errors can be indicated by writing a 1 into the error bit 0x0502.13. Acknowledging clears AL Event Request 0x0220.5.

*1 Write Enable bit 0 is self-clearing at the SOF of the next frame, Command bits [10:8] are self-clearing after the command is executed (EEPROM Busy ends). Writing "000" to the command register will also clear the error bits [14:13]. Command bits [10:8] are ignored if Error Acknowledge/Command is pending (bit 13).

*2 Error bits are cleared by writing "000" (or any valid command) to Command Register Bits [10:8].

6.4.10.4 EEPROM Address (0x0504:0x0507)

Bit	Description	ECAT	PDI	Reset Value
31:0	EEPROM Address 0: First word (= 16 bit) 1: Second word ... Actually used EEPROM Address bits: [9:0]: EEPROM size up to 16 kBit [17:0]: EEPROM size 32 kBit ... 4 Mbit [32:0]: EEPROM Emulation	r/(w)	r/(w)	

Table 60: Register 0x0504:0x0507 (PROM Address)

Note r/(w): write access depends upon the assignment of the EEPROM interface (ECAT/PDI). Write access is generally blocked if EEPROM interface is busy (0x0502.15=1).

6.4.10.5 EEPROM Data (0x0508:0x050F)

Bit	Description	ECAT	PDI	Reset Value
15:0	EEPROM Write data (data to be written to EEPROM) or EEPROM Read data (data read from EEPROM, lower bytes)	r/(w)	r/[w]	
63:16	EEPROM Read data (data read from EEPROM, higher bytes)	r/-	r/- r[w]	

Table 61: Register 0x0508:0x050F (PROM Data)

Note r/(w): write access depends upon the assignment of the EEPROM interface (ECAT/PDI). Write access is generally blocked if EEPROM interface is busy (0x0502.15=1).

Note r/[w]: write access for EEPROM emulation if read or reload command is pending.

6.4.11 ESC Parameter RAM

6.4.11.1 MFC IO Block Configuration (0x0580:0x05E1)

Byte	Description	ECAT	PDI	Reset Value
Bytes 96...0	MFC IO block configuration vector for - crossbar mapping and IO signal assignment - High voltage IO (HVIO) configuration - Switching regulator configuration - Memory block mapping - and MFC IO block register configuration	r/w	r/w	

Table 62: Register 0x0580:0x05E1 (MFC IO Config)

The content of this address block in the ESC Parameter RAM can be automatically loaded from the SII EEPROM after reset/power-up as a configuration vector that is written to addresses 0x0580:0x05E1 in the ESC's memory space.

The respective data in the SII EEPROM must be of Category 1!

Nevertheless, MFC IO configuration data can also be written and updated online by the EtherCAT Master via the ECAT interface or from a local application controller via the PDI interface by directly accessing addresses 0x0580:0x05E1 in the ESC's memory space.

More information on the individual configuration bytes in this configuration vector is given in Section 7.4 – [SII EEPROM MFC IO Block Parameter Map](#) and its following sections.

Example configurations are given in Section 7.10.

6.4.12 MII Management Interface

Address	Length (Byte)	Description
		MII Management Interface
0x0510:0x0511	2	MII Management Control/Status
0x0512	1	PHY Address
0x0513	1	PHY Register Address
0x0514:0x0515	2	PHY Data
0x0516	1	MII Management ECAT Access State
0x0517	1	MII Management PDI Access State
0x0518:0x051B	4	PHY Port Status

Table 63: MII Management Interface Register Overview

6.4.12.1 MII Management Control/Status (0x0510:0x0511)

Bit	Description	ECAT	PDI	Reset Value
0	Write enable*: 0: Write disabled 1: Write enabled This bit is always 1 if PDI has MI control.	r/(w)	r/-	
1	Management Interface can be controlled by PDI (registers 0x0516:0x0517): 0: Only ECAT control 1: PDI control possible	r/-	r/-	
2	MI link detection (link configuration, link detection, registers 0x0518:0x051B): 0: Not available 1: MI link detection active	r/-	r/-	
7:3	PHY address of port 0	r/-	r/-	
9:8	Command register*: Write: Initiate command. Read: Currently executed command Commands: 00: No command/MI idle (clear error bits) 01: Read 10: Write Others: Reserved/invalid commands (do not issue)	r/(w)	r/(w)	
12:10	Reserved, write 0	r/-	r/-	

Bit	Description	ECAT	PDI	Reset Value
13	Read error: 0: No read error 1: Read error occurred (PHY or register not available) Cleared by writing to this register.	r/(w)	r/(w)	
14	Command error: 0: Last Command was successful 1: Invalid command or write command without Write Enable Cleared with a valid command or by writing "00" to Command register bits [9:8].	r/-	r/-	
15	Busy: 0: MI control state machine is idle 1: MI control state machine is active	r/-	r/-	

Table 64: Register 0x0510:0x0511 (MI Cntrl/State)

Note r/ (w): write access depends on assignment of MI (ECAT/PDI). Write access is generally blocked if Management interface is busy (0x0510.15=1).

* Write enable bit 0 is self-clearing at the SOF of the next frame (or at the end of the PDI access), Command bits [9:8] are self-clearing after the command is executed (Busy ends). Writing "00" to the command register will also clear the error bits [14:13]. The Command bits are cleared after the command is executed.

6.4.12.2 PHY Address (0x0512)

Bit	Description	ECAT	PDI	Reset Value
0:4	PHY Address	r/(w)	r/(w)	
6:5	Reserved, write 0	r/-	r/-	
7	Show configured PHY address of port 0-3 in register 0x0510.7:3. Select port x with bits [4:0] of this register (valid values are 0-3): 0: Show address of port 0 (offset) 1: Show individual address of port x	r/(w)	r/(w)	

Table 65: Register 0x0512 (PHY Address)

Note r/ (w): write access depends on assignment of MI (ECAT/PDI). Write access is generally blocked if Management interface is busy (0x0510.15=1).

6.4.12.3 PHY Register Address (0x0513)

Bit	Description	ECAT	PDI	Reset Value
4:0	Address of PHY Register that shall be read/written	r/(w)	r/(w)	
7:5	Reserved, write 0	r/(w)	r/(w)	

*Table 66: Register 0x0513 (PHY Register Address)***Note**

r/ (w): write access depends on assignment of MI (ECAT/PDI). Write access is generally blocked if Management interface is busy (0x0510.15=1).

6.4.12.4 PHY Data (0x0514:0x0515)

Bit	Description	ECAT	PDI	Reset Value
15:0	PHY Read/Write Data	r/(w)	r/(w)	

*Table 67: Register 0x0514:0x0515 (PHY Data)***Note**

r/ (w): write access depends on assignment of MI (ECAT/PDI). Access is generally blocked if Management interface is busy (0x0510.15=1).

6.4.12.5 MII Management ECAT Access State (0x0516)

Bit	Description	ECAT	PDI	Reset Value
31:0	Access to MII management: 0: ECAT enables PDI takeover of MII management control 1: ECAT claims exclusive access to MII management	r/(w)	r/-	
31:0	Reserved, write 0	r/-	r/-	

*Table 68: Register 0x0516 (MI ECAT State)***Note**

r/ (w): write access is only possible if 0x0517.0=0.

6.4.12.6 MII Management PDI Access State (0x0517)

Bit	Description	ECAT	PDI	Reset Value
0	Access to MII management: 0: ECAT has access to MII management 1: PDI has access to MII management	r/-	r/(w)	
1	Force PDI Access State: 0: Do not change Bit 0x0517.0 1: Reset Bit 0x0517.0 to 0	r/w	r/-	
7:2	Reserved, write 0	r/-	r/-	

Table 69: Register 0x0517 (MI PDI State)

6.4.12.7 PHY Port Status (0x0518:0x051B)

Bit	Description	ECAT	PDI	Reset Value
0	Physical link status (PHY status register 1.2): 0: No physical link / 1: Physical link detected	r/-	r/-	
1	Link status (100 Mbit/s, Full Duplex, Autonegotiation): 0: No link / 1: Link detected	r/-	r/-	
2	Link status error: 0: No error 1: Link error, link inhibited	r/-	r/-	
3	Read error: 0: No read error occurred 1: A read error has occurred Cleared by writing any value to at least one of the PHY Status Port registers.	r/ (w clr)	r/ (w clr)	
4	Link partner error: 0: No error detected / 1: Link partner error	r/-	r/-	
5	PHY configuration updated: 0: No update 1: PHY configuration was updated Cleared by writing any value to at least one of the PHY Status Port registers.	r/ (w clr)	r/ (w clr)	
31:0	Reserved	r/-	r/-	

Table 70: Register 0x0518+y (PHY Port Status)

Note

r/(w): write access depends on assignment of MI (ECAT/PDI).

6.4.13 FMMUs

Address	Length (Byte)	Description
0x0600:0x06FF	16x16	FMMU[15:0]
+0x0:0x3	4	Logical Start Address
+0x4:0x5	2	Length
+0x6	1	Logical Start bit
+0x7	1	Logical Stop bit
+0x8:0x9	2	Physical Start Address
+0xA	1	Physical Start bit
+0xB	1	Type
+0xC	1	Activate
+0xD:0xF	3	Reserved

Table 71: FMMU Register Overview

For the following registers use *y* as FMMU number.

See the device features on how many FMMUs are supported in a specific ESC device.

6.4.13.1 Logical Start Address (+0x0:0x3)

Bit	Description	ECAT	PDI	Reset Value
31:0	Logical start address within the EtherCAT Address Space.	r/w	r/-	

Table 72: Register 0x06y0:0x06y3 (Log Start Addr)

6.4.13.2 Length (+0x4:0x5)

Bit	Description	ECAT	PDI	Reset Value
15:0	Offset from the first logical FMMU Byte to the last FMMU Byte + 1 (e.g., if two bytes are used then this parameter shall contain 2)	r/w	r/-	

Table 73: Register 0x06y4:0x06y5 (FMMU Length)

6.4.13.3 Logical Start bit (+0x6)

Bit	Description	ECAT	PDI	Reset Value
2:0	Logical starting bit that shall be mapped (bits are counted from least significant bit (=0) to most significant bit(=7)	r/w	r/-	
7:3	Reserved, write 0	r/-	r/-	

Table 74: Register 0x06y6 (Log. Start Bit)

6.4.13.4 Logical Stop bit (+0x7)

Bit	Description	ECAT	PDI	Reset Value
2:0	Last logical bit that shall be mapped (bits are counted from least significant bit (=0) to most significant bit(=7)	r/w	r/-	
7:3	Reserved, write 0	r/-	r/-	

Table 75: Register 0x06y7 (Log. Stop Bit)

6.4.13.5 Physical Start Address (+0x8:0x9)

Bit	Description	ECAT	PDI	Reset Value
	Physical Start Address (mapped to logical Start address)	r/w	r/-	

Table 76: Register 0x06y8:0x06y9 (Phy. Start Addr)

6.4.13.6 Physical Start bit (+0xA)

Bit	Description	ECAT	PDI	Reset Value
2:0	Physical starting bit as target of logical start bit mapping (bits are counted from least significant bit (=0) to most significant bit(=7)	r/w	r/-	
7:3	Reserved, write 0	r/-	r/-	

Table 77: Register 0x06yA (Phy. Start Bit)

6.4.13.7 Type (+0xB)

Bit	Description	ECAT	PDI	Reset Value
0	0: Ignore mapping for read accesses 1: Use mapping for read accesses	r/w	r/-	
1	0: Ignore mapping for write accesses 1: Use mapping for write accesses	r/w	r/-	
7:2	Reserved, write 0	r/-	r/-	

*Table 78: Register 0x06yB (FMMU Type)***6.4.13.8 Activate (+0xC)**

Bit	Description	ECAT	PDI	Reset Value
0	0: FMMU deactivated 1: FMMU activated. FMMU checks logical addressed blocks to be mapped according to mapping configured	r/w	r/-	
7:1	Reserved, write 0	r/-	r/-	

*Table 79: Register 0x06yC (FMMU Activate)***6.4.13.9 Reserved (+0xD:0xF)**

Bit	Description	ECAT	PDI	Reset Value
23:0	Reserved, write 0	r/-	r/-	

Table 80: Register 0x06yD:0x06yF (Reserved)

6.4.14 SyncManagers

Address	Length (Byte)	Description
0x0800:0x087F	16x8	SyncManager[15:0]
+0x0:0x1	2	Physical Start Address
+0x2:0x3	2	Length
+0x4	1	Control Register
+0x5	1	Status Register
+0x6	1	Activate
+0x7	1	PDI Control

Table 81: SyncManager Register Overview

For the following registers use y as SM number.
See the device features on how many SMs are supported in a specific ESC device.

6.4.14.1 Physical Start Address (+0x0:0x1)

Bit	Description	ECAT	PDI	Reset Value
15:0	Specifies first byte that will be handled by Sync-Manager	r/(w)	r/-	

Table 82: Register 0x0800+y*8:0x0801+y*8 (Phy. Start Addr)

Note r/(w): Register can only be written if SyncManager is disabled (+0x6.0 = 0).

6.4.14.2 Length (+0x2:0x3)

Bit	Description	ECAT	PDI	Reset Value
15:0	Number of bytes assigned to SyncManager (shall be greater 1, otherwise SyncManager is not activated. If set to 1, only Watchdog Trigger is generated if configured)	r/(w)	r/-	

Table 83: Register 0x0802+y*8:0x0803+y*8 (SM Length)

Note r/(w): Register can only be written if SyncManager is disabled (+0x6.0 = 0).

6.4.14.3 Control Register (+0x4)

Bit	Description	ECAT	PDI	Reset Value
1:0	Operation Mode: 00: Buffered (3 buffer mode) 01: Reserved 10: Mailbox (Single buffer mode) 11: Reserved	r/(w)	r/-	
3:2	Direction: 00: Read: ECAT read access, PDI write access. 01: Write: ECAT write access, PDI read access. 10: Reserved 11: Reserved	r/(w)	r/-	
4	Interrupt in ECAT Event Request Register: 0: Disabled 1: Enabled	r/(w)	r/-	
5	Interrupt in PDI Event Request Register: 0: Disabled 1: Enabled	r/(w)	r/-	
6	Watchdog Trigger Enable: 0: Disabled 1: Enabled	r/w	r/-	
7	Reserved, write 0	r/-	r/-	

Table 84: Register 0x0804+y*8 (SM Control)

Note

r/(w): Register can only be written if SyncManager is disabled (+0x6.0 = 0).

6.4.14.4 Status Register (+0x5)

Bit	Description	ECAT	PDI	Reset Value
0	Interrupt Write: 1: Interrupt after buffer was completely and successfully written 0: Interrupt cleared after first byte of buffer was read NOTE: This interrupt is signaled to the reading side if enabled in the SM Control register.	r/-	r/-	
1	Interrupt Read: 1: Interrupt after buffer was completely and successful read 0: Interrupt cleared after first byte of buffer was written NOTE: This interrupt is signaled to the writing side if enabled in the SM Control register.	r/-	r/-	

Bit	Description	ECAT	PDI	Reset Value
2	Reserved	r/-	r/-	
3	Mailbox mode: mailbox status: 0: Mailbox empty 1: Mailbox full Buffered mode: reserved	r/-	r/-	
5:4	Buffered mode: buffer status (last written buffer): 00: 1. buffer 01: 2. buffer 10: 3. buffer 11: (no buffer written) Mailbox mode: reserved	r/-	r/-	
6	Read buffer in use (opened)	r/-	r/-	
7	Write buffer in use (opened)	r/-	r/-	

Table 85: Register 0x0805+y*8 (SM Status)

6.4.14.5 Activate (+0x6)

Bit	Description	ECAT	PDI	Reset Value
0	SyncManager Enable/Disable: 0: Disable: Access to Memory without Sync-Manager control 1: Enable: SyncManager is active and controls Memory area set in configuration	r/w	r/ (w ack)*	
1	Repeat Request: A toggle of Repeat Request means that a mailbox retry is needed (primarily used in conjunction with ECAT Read Mailbox)	r/w	r/-	
5:2	Reserved, write 0	r/-	r/ (w ack)*	
6	Latch Event ECAT: 0: No 1: Generate Latch event if EtherCAT master issues a buffer exchange	r/w	r/ (w ack)*	
7	Latch Event PDI: 0: No 1: Generate Latch events if PDI issues a buffer exchange or if PDI accesses buffer start address	r/w	r/ (w ack)*	

Table 86: Register 0x0806+y*8 (SM Activate)

* PDI register function acknowledge by Write command is disabled: Reading this register from PDI in all SMs which have changed activation clears AL Event Request 0x0220. 4. Writing to this register from PDI is

not possible.

PDI register function acknowledge by Write command is enabled: Writing this register from PDI in all SMs which have changed activation clears AL Event Request 0x0220. 4. Writing to this register from PDI is possible; write value is ignored (write 0).

6.4.14.6 PDI Control (+0x7)

Bit	Description	ECAT	PDI	Reset Value
0	Deactivate SyncManager: Read: 0: Normal operation, SyncManager activated. 1: SyncManager deactivated and reset Sync-Manager locks access to Memory area. Write: 0: Activate SyncManager 1: Request SyncManager deactivation NOTE: Writing 1 is delayed until the end of a frame which is currently processed.	r/-	r/w	
1	Repeat Ack: If this is set to the same value as set by Repeat Request, the PDI acknowledges the execution of a previous set Repeat request.	r/-	r/w	
7:2	Reserved, write 0	r/-	r/-	

Table 87: Register 0x0807+y*8 (SM PDI Control)

6.4.15 Distributed Clocks Receive Times

Depending on the available width of the Distributed Clocks feature the time stamp registers are either 32 bit (4 bytes) or 64 bits (8 bytes) wide. Please check the feature summary of the respective TRINAMIC ESC device.

6.4.15.1 Receive Time Port 0 (0x0900:0x0903)

Bit	Description	ECAT	PDI	Reset Value
31:0	Write: A write access to register 0x0900 with BWR or FPWR latches the local time of the beginning of the receive frame (start first bit of preamble) at each port. Read: Local time of the beginning of the last receive frame containing a write access to this register.	r/w (special function)	r/-	

Table 88: Register 0x0900:0x0903 (Rcv Time P0)

Note The time stamps cannot be read in the same frame in which this register was written.

6.4.15.2 Receive Time Port 1 (0x0904:0x0907)

Bit	Description	ECAT	PDI	Reset Value
31:0	Local time of the beginning of a frame (start first bit of preamble) received at port 1 containing a BWR or FPWR to Register 0x0900.	r/-	r/-	

Table 89: Register 0x0904:0x0907 (Rcv Time P1)

6.4.16 Distributed Clocks Time Loop Control Unit

Time Loop Control unit is usually assigned to ECAT. Write access to Time Loop Control registers by PDI (and not ECAT) depends on explicit hardware configuration and on the used ESC type. Check the device features for availability.

6.4.16.1 System Time (0x0910:0x0917)

Bit	Description	ECAT	PDI	Reset Value
0:63	ECAT read access: Local copy of System Time when frame passed the reference clock (i.e., including System Time Delay). Time latched at beginning of the frame (Ethernet SOF delimiter)	r	-	
63:0	PDI read access: Local copy of the System Time. Time latched when reading first byte (0x0910)	-	r	
31:0	Write access: Written value will be compared with the local copy of the System time. The result is an input to the time control loop. NOTE: written value will be compared at the end of the frame with the latched (SOF) local copy of the System time if at least the first byte (0x0910) was written.	(w) (special function)	r/-	
31:0	Write access: Written value will be compared with Latch0 Time Positive Edge time. The result is an input to the time control loop. NOTE: written value will be compared at the end of the access with Latch0 Time Positive Edge (0x09B0:0x09B3) if at least the last byte (0x0913) was written.	-	(w) (special function)	

Table 90: Register 0x0910:0x0917 (System Time)

Note

Write access to this register depends upon ESC configuration (typically ECAT, PDI only with explicit ESC configuration: System Time PDI controlled).

6.4.16.2 Receive Time ECAT Processing Unit (0x0918:0x091F)

Bit	Description	ECAT	PDI	Reset Value
63:0	Local time of the beginning of a frame (start first bit of preamble) received at the ECAT Processing Unit containing a write access to Register 0x0900 NOTE: E.g., if port 0 is open, this register reflects the Receive Time Port 0 as a 64 Bit value.	r/-	r/-	

Bit	Description	ECAT	PDI	Reset Value
-----	-------------	------	-----	-------------

Table 91: Register 0x0918:0x091F (Rcv Time EPU)

6.4.16.3 System Time Offset (0x0920:0x0927)

Bit	Description	ECAT	PDI	Reset Value
63:0	Difference between local time and System Time. Offset is added to the local time.	r/(w)	r/(w)	

Table 92: Register 0x0920:0x0927 (Sys Time Offset)

Note

Write access to this register depends upon ESC configuration (typically ECAT, PDI only with explicit ESC configuration: System Time PDI controlled). Reset internal system time difference filter and speed counter filter by writing Speed Counter Start (0x0930:0x0931) after changing this value.

6.4.16.4 System Time Delay (0x0928:0x092B)

Bit	Description	ECAT	PDI	Reset Value
31:0	Delay between Reference Clock and the ESC	r/(w)	r/(w)	

Table 93: Register 0x0928:0x092B (Sys Time Delay)

Note

Write access to this register depends upon ESC configuration (typically ECAT, PDI only with explicit ESC configuration: System Time PDI controlled). Reset internal system time difference filter and speed counter filter by writing Speed Counter Start (0x0930:0x0931) after changing this value.

6.4.16.5 System Time Difference (0x092C:0x092F)

Bit	Description	ECAT	PDI	Reset Value
30:0	Mean difference between local copy of System Time and received System Time values	r/-	r/-	
31	0: Local copy of System Time greater than or equal received System Time 1: Local copy of System Time smaller than received System Time	r/-	r/-	

Table 94: Register 0x092C:0x092F (Sys Time Diff)

6.4.16.6 Speed Counter Start (0x0930:0x0931)

Bit	Description	ECAT	PDI	Reset Value
14:0	Bandwidth for adjustment of local copy of System Time (larger values → smaller bandwidth and smoother adjustment) A write access resets System Time Difference (0x092C:0x092F) and Speed Counter Diff (0x0932:0x0933). Minimum value: 0x0080 to 0x3FFF	r/(w)	r/(w)	
15	Reserved, write 0	r/(w)	r/-	

Table 95: Register 0x0930:0x931 (Speed Cnt Start)

Note

Write access to this register depends upon ESC configuration (typically ECAT, PDI only with explicit ESC configuration: System Time PDI controlled).

6.4.16.7 Speed Counter Diff (0x0932:0x0933)

Bit	Description	ECAT	PDI	Reset Value
15:0	Representation of the deviation between local clock period and reference clock's clock period (representation: two's complement) Range: $\pm(\text{Speed Counter Start} - 0x7F)$	r/-	r/-	

Table 96: Register 0x0932:0x0933 (Speed Cnt Diff)

Note

Calculate the clock deviation after System Time Difference has settled at a low value as follows:

$$\text{Deviation} = \frac{\text{SpeedCntDiff}}{5 * (\text{SpeedCntStart} + \text{SpeedCntDiff} + 2) * (\text{SpeedCntStart} - \text{SpeedCntDiff} + 2)}$$

6.4.16.8 System Time Difference Filter Depth (0x0934)

Bit	Description	ECAT	PDI	Reset Value
3:0	Filter depth for averaging the received System Time deviation. A write access resets System Time Difference (0x092C:0x092F)	r/(w)	r/(w)	
7:4	Reserved, write 0	r/-	r/-	

*Table 97: Register 0x0934 (Sys Time Diff Filter)***Note**

Write access to this register depends upon ESC configuration (typically ECAT, PDI only with explicit ESC configuration: System Time PDI controlled).

6.4.16.9 Speed Counter Filter Depth (0x0935)

Bit	Description	ECAT	PDI	Reset Value
3:0	Filter depth for averaging the clock period deviation. A write access resets the internal speed counter filter.	r/(w)	r/(w)	
7:4	Reserved, write 0	r/-	r/-	

Table 98: Register 0x0935 (Speed Cnt Filter Depth)

6.4.17 Distributed Clocks Cyclic Unit Control

6.4.17.1 Cyclic Unit Control (0x0980)

Bit	Description	ECAT	PDI	Reset Value
0	SYNC out unit control: 0: ECAT controlled 1: PDI controlled	r/w	r/-	
3:1	Reserved, write 0	r/-	r/-	
4	Latch In unit 0: 0: ECAT controlled 1: PDI controlled NOTE: Always 1 (PDI controlled) if System Time is PDI controlled. Latch interrupt is routed to ECAT/PDI depending on this setting	r/w	r/-	
5	Latch In unit 1: 0: ECAT controlled 1: PDI controlled NOTE: Latch interrupt is routed to ECAT/PDI depending on this setting	r/w	r/-	
7:6	Reserved, write 0	r/-	r/-	

Table 99: Register 0x0980 (Cyclic Unit Cntrl)

6.4.18 Distributed Clocks SYNC Out Unit

6.4.18.1 SYNC Out Activation (0x0981)

Bit	Description	ECAT	PDI	Reset Value
0	Sync Out Unit activation: 0: Deactivated 1: Activated	r/(w)	r/(w)	0
1	SYNC0 generation: 0: Deactivated 1: SYNC0 pulse is generated	r/(w)	r/(w)	0
2	SYNC1 generation: 0: Deactivated 1: SYNC1 pulse is generated	r/(w)	r/(w)	0
3	Auto-activation by writing Start Time Cyclic Operation (0x0990:0x0997): 0: Disabled 1: Auto-activation enabled. 0x0981.0 is set automatically after Start Time is written.	r/(w)	r/(w)	0
4	Extension of Start Time Cyclic Operation (0x0990:0x0993): 0: No extension 1: Extend 32 bit written Start Time to 64 bit	r/(w)	r/(w)	0
5	Start Time plausibility check: 0: Disabled. SyncSignal generation if Start Time is reached. 1: Immediate SyncSignal generation if Start Time is outside near future (see 0x0981.6)	r/(w)	r/(w)	0
6	Near future configuration (approx.): 0: 1/2 DC width future (2^{31} ns or 2^{63} ns) 1: 2.1 sec. future (2^{31} ns)	r/(w)	r/(w)	0
7	SyncSignal debug pulse (Vasily bit): 0: Deactivated 1: Immediately generate one ping only on SYNC0-1 according to 0x0981.(2:1) for debugging This bit is self-clearing, always read 0.	r/(w)	r/(w)	0

Table 100: Register 0x0981 (SYNC Out Activation)

Note

Write to this register depends upon setting of 0x0980.0.

6.4.18.2 Pulse Length of SYNC signals (0x0982:0x0983)

Bit	Description	ECAT	PDI	Reset Value
0	Pulse length of SyncSignals (in Units of 10ns) 0: Acknowledge mode: SyncSignal will be cleared by reading SYNC[1:0] Status register	r/-	r/-	0, later EEPROM ADR 0x0002

Table 101: Register 0x0982:0x0983 (SYNC Pulse Length)

6.4.18.3 Activation Status (0x0984)

Bit	Description	ECAT	PDI	Reset Value
0	SYNC0 activation state: 0: First SYNC0 pulse is not pending 1: First SYNC0 pulse is pending	r/-	r/-	0
1	SYNC1 activation state: 0: First SYNC1 pulse is not pending 1: First SYNC1 pulse is pending	r/-	r/-	0
2	Start Time Cyclic Operation (0x0990:0x0997) plausibility check result when Sync Out Unit was activated: 0: Start Time was within near future 1: Start Time was out of near future (0x0981.6)	r/-	r/-	0
7:3	Reserved	r/-	r/-	0

Table 102: Register 0x0984 (Activation Status)

6.4.18.4 SYNC0 Status (0x098E)

Bit	Description	ECAT	PDI	Reset Value
0	SYNC0 activation state: 0: First SYNC0 pulse is not pending 1: First SYNC0 pulse is pending	r/-	r/ (w ack)*	0
7:1	Reserved	r/-	r/ (w ack)*	0

Table 103: Register 0x098E (SYNC0 Status)

* PDI register function acknowledge by Write command is disabled: Reading this register from PDI clears AL Event Request 0x0220.2. Writing to this register from PDI is not possible.

PDI register function acknowledge by Write command is enabled: Writing this register from PDI clears AL Event Request 0x0220.2. Writing to this register from PDI is possible; write value is ignored (write 0).

6.4.18.5 SYNC1 Status (0x098F)

Bit	Description	ECAT	PDI	Reset Value
0	SYNC1 activation state: 0: First SYNC1 pulse is not pending 1: First SYNC1 pulse is pending	r/-	r/ (w ack)*	0
7:1	Reserved	r/-	r/ (w ack)*	0

Table 104: Register 0x098F (SYNC1 Status)

* PDI register function acknowledge by Write command is disabled: Reading this register from PDI clears AL Event Request 0x0220.3. Writing to this register from PDI is not possible.
PDI register function acknowledge by Write command is enabled: Writing this register from PDI clears AL Event Request 0x0220.3. Writing to this register from PDI is possible; write value is ignored (write 0).

6.4.18.6 Start Time Cyclic Operation / Next SYNC0 Pulse (0x0990:0x0997)

Bit	Description	ECAT	PDI	Reset Value
63:0	Write: Start time (System time) of cyclic operation in ns Read: System time of next SYNC0 pulse in ns	r/(w)	r/(w)	0

*Table 105: Register 0x0990:0x0997 (Start Time Cyclic Operation)***Note**

Write to this register depends upon setting of 0x0980.0. Only writable if 0x0981.0=0. Auto-activation (0x0981.3=1): upper 32 bits are automatically extended if only lower 32 bits are written within one frame.

6.4.18.7 Next SYNC1 Pulse (0x0998:0x099F)

Bit	Description	ECAT	PDI	Reset Value
63:0	System time of next SYNC1 pulse in ns	r/-	r/-	0

Table 106: Register 0x0998:0x099F (Next SYNC1)

6.4.18.8 SYNC0 Cycle Time (0x09A0:0x09A3)

Bit	Description	ECAT	PDI	Reset Value
31:0	WTime between two consecutive SYNC0 pulses in ns. 0: Single shot mode, generate only one SYNC0 pulse.	r/(w)	r/(w)	0

Table 107: Register 0x09A0:0x09A3 (SYNC0 Cycle Time)

Note Write to this register depends upon setting of 0x0980.0.

6.4.18.9 SYNC1 Cycle Time (0x09A4:0x09A7)

Bit	Description	ECAT	PDI	Reset Value
31:0	Time between SYNC1 pulses and SYNC0 pulse in ns	r/(w)	r/(w)	0

Table 108: Register 0x09A4:0x09A7 (SYNC1 Cycle Time)

Note Write to this register depends upon setting of 0x0980.0.

6.4.19 Distributed Clocks LATCH In Unit

6.4.19.1 Latch0 Control (0x09A8)

Bit	Description	ECAT	PDI	Reset Value
0	Latch0 positive edge: 0: Continuous Latch active 1: Single event (only first event active)	r/(w)	r/(w)	0
1	Latch0 negative edge: 0: Continuous Latch active 1: Single event (only first event active)	r/(w)	r/(w)	0
7:2	Reserved, write 0	r/-	r/-	0

Table 109: Register 0x09A8 (Latch0 Control)

Note Write access depends upon setting of 0x0980 . 4.

6.4.19.2 Latch1 Control (0x09A9)

Bit	Description	ECAT	PDI	Reset Value
0	Latch1 positive edge: 0: Continuous Latch active 1: Single event (only first event active)	r/(w)	r/(w)	0
1	Latch01 negative edge: 0: Continuous Latch active 1: Single event (only first event active)	r/(w)	r/(w)	0
7:2	Reserved, write 0	r/-	r/-	0

Table 110: Register 0x09A9 (Latch1 Control)

Note Write access depends upon setting of 0x0980 . 5.

6.4.19.3 Latch0 Status (0x09AE)

Bit	Description	ECAT	PDI	Reset Value
0	Event Latch0 positive edge. 0: Positive edge not detected or continuous mode 1: Positive edge detected in single event mode only. Flag cleared by reading out Latch0 Time Positive Edge.	r/-	r/-	0
1	Event Latch0 negative edge. 0: Negative edge not detected or continuous mode 1: Negative edge detected in single event mode only. Flag cleared by reading out Latch0 Time Negative Edge.	r/-	r/-	0
2	Latch0 pin state	r/-	r/-	0
7:3	Reserved	r/-	r/-	0

Table 111: Register 0x09AE (Latch0 Status)

6.4.19.4 Latch1 Status (0x09AF)

Bit	Description	ECAT	PDI	Reset Value
0	Event Latch1 positive edge. 0: Positive edge not detected or continuous mode 1: Positive edge detected in single event mode only. Flag cleared by reading out Latch1 Time Positive Edge.	r/-	r/-	0
1	Event Latch1 negative edge. 0: Negative edge not detected or continuous mode 1: Negative edge detected in single event mode only. Flag cleared by reading out Latch1 Time Negative Edge.	r/-	r/-	0
2	Latch1 pin state	r/-	r/-	0
7:3	Reserved	r/-	r/-	0

Table 112: Register 0x09AF (Latch1 Status)

6.4.19.5 Latch0 Time Positive Edge (0x09B0:0x09B7)

Bit	Description	ECAT	PDI	Reset Value
63:0	Register captures System time at the positive edge of the Latch0 signal.	r(ack)/-	r/ (w ack)*	0

Table 113: Register 0x09B0:0x09B7 (Latch0 Time Pos Edge)

Note Register bits [63:8] are internally latched (ECAT/PDI independently) when bits [7:0] are read, which guarantees reading a consistent value. Reading this register from ECAT clears Latch0 Status 0x09AE.0 if 0x0980.4=0. Writing to this register from ECAT is not possible.

* PDI register function acknowledge by Write command is disabled: Reading this register from PDI if 0x0980.4=1 clears Latch0 Status 0x09AE.0. Writing to this register from PDI is not possible.

PDI register function acknowledge by Write command is enabled: Writing this register from PDI if 0x0980.4=1 clears Latch0 Status 0x09AE.0. Writing to this register from PDI is possible; write value is ignored (write 0).

6.4.19.6 Latch0 Time Negative Edge (0x09B8:0x09BF)

Bit	Description	ECAT	PDI	Reset Value
63:0	Register captures System time at the negative edge of the Latch0 signal.	r(ack)/-	r/ (w ack)*	0

Table 114: Register 0x09B8:0x09BF (Latch0 Time Neg Edge)

Note Register bits [63:8] are internally latched (ECAT/PDI independently) when bits [7:0] are read, which guarantees reading a consistent value. Reading this register from ECAT clears Latch0 Status 0x09AE.1 if 0x0980.4=0. Writing to this register from ECAT is not possible.

* PDI register function acknowledge by Write command is disabled: Reading this register from PDI if 0x0980.4=1 clears Latch0 Status 0x09AE.1. Writing to this register from PDI is not possible.

PDI register function acknowledge by Write command is enabled: Writing this register from PDI if 0x0980.4=1 clears Latch0 Status 0x09AE.1. Writing to this register from PDI is possible; write value is ignored (write 0).

6.4.19.7 Latch1 Time Positive Edge (0x09C0:0x09C7)

Bit	Description	ECAT	PDI	Reset Value
63:0	Register captures System time at the positive edge of the Latch1 signal.	r(ack)/-	r/ (w ack)*	0

Table 115: Register 0x09C0:0x09C7 (Latch1 Time Pos Edge)

Note

Register bits [63:8] are internally latched (ECAT/PDI independently) when bits [7:0] are read, which guarantees reading a consistent value. Reading this register from ECAT clears Latch1 Status 0x09AF.0 if 0x0980.5=0. Writing to this register from ECAT is not possible.

* PDI register function acknowledge by Write command is disabled: Reading this register from PDI if 0x0980.5=1 clears Latch1 Status 0x09AF.0. Writing to this register from PDI is not possible.

PDI register function acknowledge by Write command is enabled: Writing this register from PDI if 0x0980.5=1 clears Latch1 Status 0x09AF.0. Writing to this register from PDI is possible; write value is ignored (write 0).

6.4.19.8 Latch1 Time Negative Edge (0x09C8:0x09CF)

Bit	Description	ECAT	PDI	Reset Value
63:0	Register captures System time at the negative edge of the Latch1 signal.	r(ack)/-	r/ (w ack)*	0

Table 116: Register 0x09C8:0x09CF (Latch1 Time Neg Edge)

Note

Register bits [63:8] are internally latched (ECAT/PDI independently) when bits [7:0] are read, which guarantees reading a consistent value. Reading this register from ECAT clears Latch1 Status 0x09AF.0 if 0x0980.5=0. Writing to this register from ECAT is not possible.

* PDI register function acknowledge by Write command is disabled: Reading this register from PDI if 0x0980.5=1 clears Latch1 Status 0x09AF.1. Writing to this register from PDI is not possible.

PDI register function acknowledge by Write command is enabled: Writing this register from PDI if 0x0980.5=1 clears Latch1 Status 0x09AF.1. Writing to this register from PDI is possible; write value is ignored (write 0).

6.4.20 Distributed Clocks SyncManager Event Times

6.4.20.1 EtherCAT Buffer Change Event Time (0x09F0:0x09F3)

Bit	Description	ECAT	PDI	Reset Value
31:0	Register captures local time of the beginning of the frame which causes at least one SM to assert an ECAT event	r/-	r/-	0

Table 117: Register 0x09F0:0x09F3 (ECAT Buffer Change Event Time)

Note Register bits [31:8] are internally latched (ECAT/PDI independently) when bits [7:0] are read, which guarantees reading a consistent value.

6.4.20.2 PDI Buffer Start Event Time (0x09F8:0x09FB)

Bit	Description	ECAT	PDI	Reset Value
31:0	Register captures local time when at least one SyncManager asserts an PDI buffer start event	r/-	r/-	0

Table 118: Register 0x09F8:0x09FB (PDI Buffer Start Event Time)

Note Register bits [31:8] are internally latched (ECAT/PDI independently) when bits [7:0] are read, which guarantees reading a consistent value.

6.4.20.3 PDI Buffer Change Event Time (0x09FC:0x09FF)

Bit	Description	ECAT	PDI	Reset Value
31:0	Register captures local time when at least one SyncManager asserts an PDI buffer start event	r/-	r/-	0

Table 119: Register 0x09FC:0x09FF (PDI Buffer Change Event Time)

Note Register bits [31:8] are internally latched (ECAT/PDI independently) when bits [7:0] are read, which guarantees reading a consistent value.

6.4.21 ESC Specific

6.4.21.1 Product ID (0x0E00:0x0E07)

Bit	Description	ECAT	PDI	Reset Value
63:0	Product ID	r/-	r/-	TMC8460: 0x0000000001008460 TMC8461: 0x0000000001108461 TMC8462: 0x0000000001108461 TMC8670: 0x0000000001008670

Table 120: Register 0x0E00:0x0E07 (Product ID)

6.4.21.2 Vendor ID (0x0E08:0x0E0F)

Bit	Description	ECAT	PDI	Reset Value
63:0	Vendor ID: [23:0] Company [31:24] Department NOTE: Test Vendor IDs [31:28]=0xE	r/-	r/-	TMC8460: 0x0000000100000286 TMC8461: 0x0000000100000286 TMC8462: 0x0000000100000286 TMC8670: 0x0000000100000286

Table 121: Register 0x0E08:0x0E0F (Vendor ID)

6.4.22 Process Data RAM

6.4.22.1 Process Data RAM (0x1000:0xFFFF)

The Process Data RAM starts at address 0x1000.

The size of the Process Data RAM depends on the device.

Bytes	Description	ECAT	PDI	Reset Value
---	Process Data RAM	(r/w)	(r/w)	Random/undefined

Table 122: Process Data RAM (0x1000:0xFFFF)

Note

(r/w): Process Data RAM is only accessible if EEPROM was correctly loaded (register 0x0110.0 = 1).

Device	Process Data RAM Size	Upper RAM Address
TMC8460	16kBytes	0x4FFF
TMC8461	16kBytes	0x4FFF
TMC8462	16kBytes	0x4FFF
TMC8670	4kBytes	0x1FFF

Table 123: Process Data RAM Size

7 MFC IO Block Description

7.1 General Information

The MFC IO block includes a set of functions realized as dedicated hardware blocks.

The MFC IO block offers 24 fully configurable IOs that can be used with any function of the MFC IO block. 16 low voltage IOs capable of 3.3V or 5V and 8 high voltage IOs capable of up to 24V are available.

The MFC IO block functions can be used either via the MFC IO control interface (see section 5.2) or via EtherCAT data objects mapped as registers to the Process Data Memory.

When using the MFC IO control interface the microcontroller has full control over the MFC IO block and its hardware functions. This allows for offloading some firmware tasks towards the TMC8462A, to do system level control, or to extend the microcontroller's IO capabilities.

When accessing the MFC IO block via EtherCAT data objects, centralized control from the EtherCAT master is enabled. It is also possible to use the TMC8462A in device emulation mode without any microcontroller connected while still using the dedicated hardware blocks and functions of the MFC IO block. For example, the SPI master interface of the MFC IO block can be used to be connected to a position sensor, which is read out by the EtherCAT master.

Configuration of the MFC IO block is done via the SII EEPROM at startup or by the EtherCAT master or microcontroller after startup.

SII EEPROM configuration data must be of category 1 and is automatically loaded at startup and written into the ESC Parameter Ram section of the [EtherCAT Register Set](#) starting at address 0x0580 (see Section 6.4.11.1).

The ESC Parameter RAM section can also be written by the EtherCAT master or the local microcontroller for direct configuration or to modify configuration after startup.

The block diagram in Figure 31 shows the general approach for the MFC IO block configuration.

Note

Even if the MFC IO block is only accessed from the microcontroller and the EtherCAT access feature is not used, it is recommended to store at least the crossbar configuration (section 7.5), the HVIO configuration (section 7.6) and the switching regulator configuration (section 7.7) in the SII EEPROM.

By doing this, the settings are loaded faster than having to write them from the microcontroller and it also reduces the memory usage on the microcontroller itself.

Note

The MFC IO block parameters and register can be mapped into the the ESC Process Data RAM. For some applications and combinations it is possible to use these registers as cyclic data within a SyncManager. This is not possible for all registers and combinations and depends on the use case!

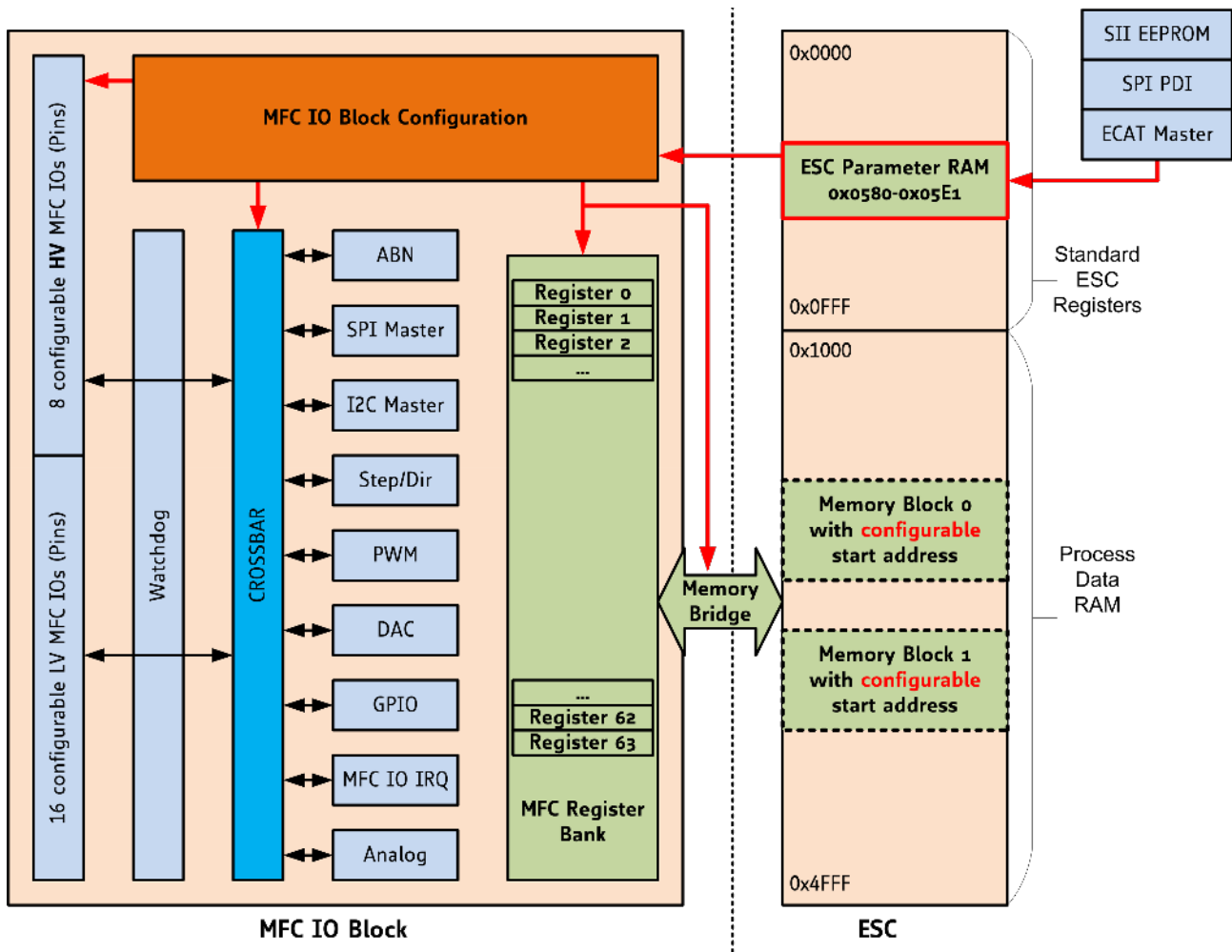

Figure 31: MFC IO Block Configuration using the ESC Parameter RAM

7.2 MFC IO Register Overview

The MFC IO block contains a range of registers dedicated to the specific sub-blocks. The registers can always be read by a microcontroller via the MFC IO Control SPI Interface. The registers can only be exclusively written by either the microcontroller via the MFC IO Control SPI Interface or by the EtherCAT master via a mapping in the ESC's DPRAM.

The analog and high voltage block can also be configured using dedicated registers of the MFC IO block.

Register	Function	Write/Read	Size (Byte)	Padding Bytes (see section 7.8)
0	ENC_MODE	W	2	2
1	ENC_STATUS	R	1	3
2	X_ENC	W	4	0
3	X_ENC	R	4	0
4	ENC_CONST	W	4	0
5	ENC_LATCH	R	4	0
6	SPI_RX_DATA	R	8	0
7	SPI_TX_DATA	W	8	0
8	SPI_CONF	W	2	2
9	SPI_STATUS	R	1	3
10	SPI_LENGTH	W	1	3
11	SPI_TIME	W	1	3
12	I2C_TIMEBASE	W	1	3
13	I2C_CONTROL	W	1	3
14	I2C_STATUS	R	1	3
15	I2C_ADDRESS	W	1	3
16	I2C_DATA_R	R	1	3
17	I2C_DATA_W	W	1	3
18	SD_CH0_STEPRATE	W	4	0
19	SD_CH1_STEPRATE	W	4	0
20	SD_CH2_STEPRATE	W	4	0
21	SD_CH0_STEP_COUNT	R	4	0
22	SD_CH1_STEP_COUNT	R	4	0
23	SD_CH2_STEP_COUNT	R	4	0
24	SD_CH0_STEPTARGET	W	4	0
25	SD_CH1_STEPTARGET	W	4	0
26	SD_CH2_STEPTARGET	W	4	0
27	SD_CH0_COMPARE	W	4	0

Register	Function	Write/Read	Size (Byte)	Padding Bytes (see section 7.8)
28	SD_CH1_COMPARE	W	4	0
29	SD_CH2_COMPARE	W	4	0
30	SD_CH0_NEXTSR	W	4	0
31	SD_CH1_NEXTSR	W	4	0
32	SD_CH2_NEXTSR	W	4	0
33	SD_STEPLength	W	6	2
34	SD_DELAY	W	6	2
35	SD_CFG	W	3	1
36	PWM_CFG	W	8	0
37	PWM1	W	2	2
38	PWM2	W	2	2
39	PWM3	W	2	2
40	PWM4	W	2	2
41	PWM1_CNTRSHFT	W	2	2
42	PWM2_CNTRSHFT	W	2	2
43	PWM3_CNTRSHFT	W	2	2
44	PWM4_CNTRSHFT	W	2	2
45	PWM_PULSE_B_PULSE_A	W	4	0
46	PWM_PULSE_LENGTH	W	1	3
47	GPO	W	4	0
48	GPI	R	2	2
49	GPIO_CONFIG	W	2	2
50	DAC_VAL	W	2	2
51	MFCIO_IRQ_CFG	W	3	1
52	MFCIO_IRQ_FLAGS	R	3	1
53	WD_TIME	W	4	0
54	WD_CFG	W	1	3
55	WD_OUT_MASK_POL	W	8	0
56	WD_OE_POL	W	4	0
57	WD_IN_MASK_POL	W	8	0
58	WD_MAX	R	4	0
59	HV_ANA_STATUS	R	4	0
60	unused/reserved	-	0	0

Register	Function	Write/Read	Size (Byte)	Padding Bytes (see section 7.8)
61	unused/reserved	-	0	0
62	unused/reserved	-	0	0
63	SYNC1_SYNC0_EVENT_CNT	R (ECAT only)	4	0
64	HVIO_CFG	W	4	0
65	BUCK_CONV_CFG	W	2	2
66	AL_OVERRIDE	W	1	3

Table 124: MFC IO Register Overview for TMC8462A-BA

7.3 MFC IO Register Set

7.3.1 Incremental Encoder Interface

7.3.1.1 Register 0 – ENC_MODE

Bit	Description	ECAT	PDI	Range [Unit]
0	pol_A Required A polarity for an N channel event (0: neg., 1: pos.)	r/w	r/w	
1	pol_B Required B polarity for an N channel event (0: neg., 1: pos.)	r/w	r/w	
2	pol_N Defines active polarity of N (0: neg., 1: pos.)	r/w	r/w	
3	ignore_AB 0: An N event occurs only when polarities given by pol_N, pol_A and pol_B match. 1: Ignore A and B polarity for N channel event	r/w	r/w	
4	clr_cont 1: Always latch or latch and clear X_ENC upon an N event (once per revolution, it is recommended to combine this setting with edge sensitive N event)	r/w	r/w	
5	clr_once 1: Latch or latch and clear X_ENC on the next N event following the write access	r/w	r/w	
7:6	neg_edge bit <i>n</i> & pos_edge bit <i>p</i> <i>n p</i> : N channel event sensitivity 0 0: N channel event is active during an active N event level 0 1: N channel is valid upon active going N event 1 0: N channel is valid upon inactive going N event 1 1: N channel is valid upon active going and inactive going N event	r/w	r/w	
8	clr_enc_x 0: On N event, X_ENC becomes latched to ENC_LATCH only 1: Latch & additionally clear X_ENC at N-event	r/w	r/w	
9	latch_x_act 1: Also latch XACTUAL position together with X_ENC. Allows latching the ramp generator position upon an N channel event as selected by pos_edge and neg_edge.	r/w	r/w	
10	enc_sel_decimal 0: Encoder prescaler divisor binary mode: Counts ENC_CONST(fractional part) / 65536 1: Encoder prescaler divisor decimal mode: Counts in ENC_CONST(fractional part) / 10000	r/w	r/w	
15:11	Reserved	-/-	-/-	

Table 125: MFC IO Register 0 – ENC_MODE

7.3.1.2 Register 1 – ENC_STATUS

Bit	Description	ECAT	PDI	Range [Unit]
0	n_event 1: Encoder N event detected. Status bit is cleared on read: Read (R) + clear (C) This event can also be ORed into the interrupt output signal. See Register 51 and 52 .	r+c/-	r+c/-	
7:1	Reserved	r/-	r/-	

Table 126: MFC IO Register 1 – ENC_STATUS

7.3.1.3 Register 2 – X_ENC (write)

Bit	Description	ECAT	PDI	Range [Unit]
31:0	Actual encoder position (signed)	r/w	r/w	$-2^{31} \dots + (2^{31}) - 1$

Table 127: MFC IO Register 2 – X_ENC (write)

7.3.1.4 Register 3 – X_ENC (read)

Bit	Description	ECAT	PDI	Range [Unit]
31:0	Actual encoder position (signed)	r/-	r/-	$-2^{31} \dots + (2^{31}) - 1$

Table 128: MFC IO Register 3 – X_ENC (read)

7.3.1.5 Register 4 – ENC_CONST

Bit	Description	ECAT	PDI	Range [Unit]
31:0	Accumulation constant (signed) 16 bit integer part, 16 bit fractional part X_ENC accumulates $\pm \frac{ENC_CONST}{(2^{16} * X_ENC)}$ (binary) or $\pm \frac{ENC_CONST}{(10^4 * X_ENC)}$ (decimal) ENC_MODE bit enc_sel_decimal switches between decimal and binary setting. Use the sign, to match rotation direction!	r/w	r/w	binary: $\pm [\mu steps / 2^{16}]$ $\pm (0 \dots 32767.9999847)$ decimal: $\pm (0 \dots 32767.9999)$ reset default = 1.0(= 65536)

Table 129: MFC IO Register 4 – ENC_CONST

7.3.1.6 Register 5 – ENC_LATCH

Bit	Description	ECAT	PDI	Range [Unit]
31:0	Encoder position X_ENC latched on N event	r/-	r/-	$-2^{31} \dots + (2^{31}) - 1$

Table 130: MFC IO Register 5 – ENC_LATCH

7.3.2 SPI Master Interface

7.3.2.1 Register 6 – SPI_RX_DATA

Bit	Description	ECAT	PDI	Range [Unit]
63:0	Received data from last SPI transfer For SPI transfers with less than 64 bit, the upper bits of this register are unused	r/-	r/-	

Table 131: MFC IO Register 6 – SPI_RX_DATA

7.3.2.2 Register 7 – SPI_TX_DATA

Bit	Description	ECAT	PDI	Range [Unit]
63:0	Data to transmit on next SPI transfer For SPI transfers with less than 64 bit, the upper bits of this register are unused	-/w	-/w	

Table 132: MFC IO Register 7 – SPI_TX_DATA

Note

Unless configured otherwise in the SPI_CONF register (bits 10:8), writing data into this register automatically starts transmission as soon as the highest byte (according to SPI_LENGTH configuration) has been written.
All bytes to be transmitted must be written to the register within a single access (via MFC IO Control SPI or from the DPRAM) to ensure data consistency.

7.3.2.3 Register 8 – SPI_CONF

Bit	Description	ECAT	PDI	Range [Unit]
1:0	Selection of SPI slave	r/w	r/w	
2	reserved	r/w	r/w	
3	Keep CS low after transfer for transfers greater than 64bit	r/w	r/w	
4	transmit LSB first	r/w	r/w	
5	SPI clock phase	r/w	r/w	
6	SPI clock polarity	r/w	r/w	
7	reserved	r/w	r/w	

Bit	Description	ECAT	PDI	Range [Unit]
10:8	Trigger configuration for transmission start 000 ₂ : Start when data is written into TX register 001 ₂ : Start on beginning of PWM cycle 010 ₂ : Start on center of PWM cycle 011 ₂ : Start on PWM A mark 100 ₂ : Start on PWM B mark 101 ₂ : Start on PWM A&B marks 110 ₂ : reserved 111 ₂ : Start on single trigger (Bit 15)	r/w	r/w	0 ₁₀ . . . 7 ₁₀
14:11	reserved	r/w	r/w	
15	Start transfer once when this bit is set and trigger configuration is set to 111 ₂	r/w	r/w	

Table 133: MFC IO Register 8 – SPI_CONF

7.3.2.4 Register 9 – SPI_STATUS

Bit	Description	ECAT	PDI	Range [Unit]
0	SPI transfer done, ready for next transfer	r/-	r/-	
7:1	unused	r/-	r/-	0

Table 134: MFC IO Register 9 – SPI_STATUS

7.3.2.5 Register 10 – SPI_LENGTH

Bit	Description	ECAT	PDI	Range [Unit]
5:0	SPI datagram length Example: 000111 ₂ = 8 bit datagram Example: 111111 ₂ = 64 bit datagram	-/w	-/w	0 ₁₀ . . . 63 ₁₀ [bit]
7:6	unused	-/w	-/w	0

Table 135: MFC IO Register 10 – SPI_LENGTH

7.3.2.6 Register 11 – SPI_TIME

Bit	Description	ECAT	PDI	Range [Unit]
7:0	SPI_BIT_DURATION $f_{SPI} = \frac{25MHz}{(4+(2*SPI_BIT_DURATION))}$	-/w	-/w	0 ₁₀ . . . 255 ₁₀

Table 136: MFC IO Register 11 – SPI_TIME

7.3.3 I2C Master Interface

7.3.3.1 Register 12 – I2C_TIMEBASE

Bit	Description	ECAT	PDI	Range [Unit]
7:0	I2C_BIT_DURATION 0 = off 1...255 = 1 μ s...255 μ s = 250kbit/s...980bit/s	-/w	-/w	0 ₁₀ ...255 ₁₀ [μ s]

Table 137: MFC IO Register 12 – I2C_TIMEBASE

7.3.3.2 Register 13 – I2C_CONTROL

Bit	Description	ECAT	PDI	Range [Unit]
0	receive Data and send NACK	-/w	-/w	
1	receive Data and send ACK	-/w	-/w	
2	Send Data (content of data I2C_DATA_W)	-/w	-/w	
3	Send Address (content of address register I2C_ADDRESS), incl. R/nW bit	-/w	-/w	
4	Send Stop Condition	-/w	-/w	
5	Send Start Condition (also Repeated Start)	-/w	-/w	
7:6	unused	-/w	-/w	

Table 138: MFC IO Register 13 – I2C_CONTROL

7.3.3.3 Register 14 – I2C_STATUS

Bit	Description	ECAT	PDI	Range [Unit]
0	St - Start condition sent	r/-	r/-	
1	RSt - Repeated Start condition sent	r/-	r/-	
2	ADR - Transmit Address mode	r/-	r/-	
3	RX - Read from Slave mode	r/-	r/-	
4	TX - Write to slave mode	r/-	r/-	
5	ACK - Acknowledge received/sent	r/-	r/-	
6	NAK - Not Acknowledge received/sent	r/-	r/-	
7	ERR - Error Flag	r/-	r/-	

Table 139: MFC IO Register 14 – I2C_STATUS

7.3.3.4 Register 15 – I2C_ADDRESS

Bit	Description	ECAT	PDI	Range [Unit]
0	R/nW bit	-/w	-/w	
7:1	Address	-/w	-/w	

*Table 140: MFC IO Register 15 – I2C_ADDRESS***7.3.3.5 Register 16 – I2C_DATA_R**

Bit	Description	ECAT	PDI	Range [Unit]
7:0	Received data	r/-	r/-	

*Table 141: MFC IO Register 16 – I2C_DATA_R***7.3.3.6 Register 17 – I2C_DATA_W**

Bit	Description	ECAT	PDI	Range [Unit]
7:0	Transmit data	-/w	-/w	

Table 142: MFC IO Register 17 – I2C_DATA_W

7.3.4 Step and Direction Signal Generator

7.3.4.1 Register 18 – SD_CH0_STEPRATE

Bit	Description	ECAT	PDI	Range [Unit]
31:0	Signed accumulation constant c for SD_CH0. This accumulation constant determines the time t_{STEP} between two successive steps and thereby the step frequency. The Sign (MSB) of this accumulation constant is used for the direction signal output (D0, D0n). The accumulation constant c is 2th complement. (see also Section 7.14)	-/w	-/w	$0 \dots + (2^{32}) - 1$

Table 143: MFC IO Register 18 – SD_CH0_STEPRATE

7.3.4.2 Register 19 – SD_CH1_STEPRATE

Bit	Description	ECAT	PDI	Range [Unit]
31:0	Signed accumulation constant c for SD_CH1. This accumulation constant determines the time t_{STEP} between two successive steps and thereby the step frequency. The Sign (MSB) of this accumulation constant is used for the direction signal output (D1, D1n). The accumulation constant c is 2th complement. (see also Section 7.14)	-/w	-/w	$0 \dots + (2^{32}) - 1$

Table 144: MFC IO Register 19 – SD_CH1_STEPRATE

7.3.4.3 Register 20 – SD_CH2_STEPRATE

Bit	Description	ECAT	PDI	Range [Unit]
31:0	Signed accumulation constant c for SD_CH2. This accumulation constant determines the time t_{STEP} between two successive steps and thereby the step frequency. The Sign (MSB) of this accumulation constant is used for the direction signal output (D2, D2n). The accumulation constant c is 2th complement. (see also Section 7.14)	-/w	-/w	$0 \dots + (2^{32}) - 1$

Table 145: MFC IO Register 20 – SD_CH2_STEPRATE

7.3.4.4 Register 21 – SD_CH0_STEPCOUNT

Bit	Description	ECAT	PDI	Range [Unit]
31:0	Step counter for SD_CH0. Counting up/down depending on step direction.	r/-	r/-	$-2^{31} \dots + (2^{31}) - 1$

*Table 146: MFC IO Register 21 – SD_CH0_STEPCOUNT***7.3.4.5 Register 22 – SD_CH1_STEPCOUNT**

Bit	Description	ECAT	PDI	Range [Unit]
31:0	Step counter for SD_CH1. Counting up/down depending on step direction.	r/-	r/-	$-2^{31} \dots + (2^{31}) - 1$

*Table 147: MFC IO Register 22 – SD_CH1_STEPCOUNT***7.3.4.6 Register 23 – SD_CH2_STEPCOUNT**

Bit	Description	ECAT	PDI	Range [Unit]
31:0	Step counter for SD_CH2. Counting up/down depending on step direction.	r/-	r/-	$-2^{31} \dots + (2^{31}) - 1$

*Table 148: MFC IO Register 23 – SD_CH2_STEPCOUNT***7.3.4.7 Register 24 – SD_CH0_STEPTARGET**

Bit	Description	ECAT	PDI	Range [Unit]
31:0	Steps pulses (= distance) to be made for SD_CH0. Can be overwritten at any time. When zero, no more step pulses are generated at output S0 or S0n, Reading the register returns the remaining number of step pulses to be generated.	-/w	-/w	$0 \dots + (2^{32}) - 1$

Table 149: MFC IO Register 24 – SD_CH0_STEPTARGET

7.3.4.8 Register 25 – SD_CH1_STEPTARGET

Bit	Description	ECAT	PDI	Range [Unit]
31:0	Steps pulses (= distance) to be made for SD_CH1. Can be overwritten at any time. When zero, no more step pulses are generated at output S1 or S1n, Reading the register returns the remaining number of step pulses to be generated.	-/w	-/w	$0 \dots + (2^{32}) - 1$

*Table 150: MFC IO Register 25 – SD_CH1_STEPTARGET***7.3.4.9 Register 26 – SD_CH2_STEPTARGET**

Bit	Description	ECAT	PDI	Range [Unit]
31:0	Steps pulses (= distance) to be made for SD_CH2. Can be overwritten at any time. When zero, no more step pulses are generated at output S2 or S2n, Reading the register returns the remaining number of step pulses to be generated.	-/w	-/w	$0 \dots + (2^{32}) - 1$

*Table 151: MFC IO Register 26 – SD_CH2_STEPTARGET***7.3.4.10 Register 27 – SD_CH0_COMPARE**

Bit	Description	ECAT	PDI	Range [Unit]
31:0	Comparison value to compare with actual value of SD_CH0_STEP_COUNT. When both are equal and bit 6 in SD_CFG is set, the next step rate as configured in SD_CH0_NEXTSR will be assigned and used for SD_CH0_SR.	-/w	-/w	$-2^{31} \dots + (2^{31}) - 1$

Table 152: MFC IO Register 27 – SD_CH0_COMPARE

7.3.4.11 Register 28 – SD_CH1_COMPARE

Bit	Description	ECAT	PDI	Range [Unit]
31:0	Comparison value to compare with actual value of SD_CH1_STEP_COUNT. When both are equal and bit 6 in SD_CFG is set, the next step rate as configured in SD_CH1_NEXTSR will be assigned and used for SD_CH1_SR.	-/w	-/w	$-2^{31} \dots + (2^{31}) - 1$

Table 153: MFC IO Register 28 – SD_CH1_COMPARE

7.3.4.12 Register 29 – SD_CH2_COMPARE

Bit	Description	ECAT	PDI	Range [Unit]
31:0	Comparison value to compare with actual value of SD_CH2_STEP_COUNT. When both are equal and bit 6 in SD_CFG is set, the next step rate as configured in SD_CH2_NEXTSR will be assigned and used for SD_CH2_SR.	-/w	-/w	$-2^{31} \dots + (2^{31}) - 1$

Table 154: MFC IO Register 29 – SD_CH2_COMPARE

7.3.4.13 Register 30 – SD_CH0_NEXTSR

Bit	Description	ECAT	PDI	Range [Unit]
31:0	Next accumulation constant that will be written to SD_CH0_STEPRATE at compare event.	-/w	-/w	$0 \dots + (2^{32}) - 1$

Table 155: MFC IO Register 30 – SD_CH0_NEXTSR

7.3.4.14 Register 31 – SD_CH1_NEXTSR

Bit	Description	ECAT	PDI	Range [Unit]
31:0	Next accumulation constant that will be written to SD_CH1_STEPRATE at compare event.	-/w	-/w	$0 \dots + (2^{32}) - 1$

Table 156: MFC IO Register 31 – SD_CH1_NEXTSR

7.3.4.15 Register 32 – SD_CH2_NEXTSR

Bit	Description	ECAT	PDI	Range [Unit]
31:0	Next accumulation constant that will be written to SD_CH2_STEPRATE at compare event.	-/w	-/w	$0 \dots + (2^{32}) - 1$

Table 157: MFC IO Register 32 – SD_CH2_NEXTSR

7.3.4.16 Register 33 – SD_STEPLength

Bit	Description	ECAT	PDI	Range [Unit]
15:0	Configurable step pulse length for SD_CH0 in terms of 25MHz clock cycles.	-/w	-/w	$0 \dots + (2^{16}) - 1$
31:16	Configurable step pulse length for SD_CH1 in terms of 25MHz clock cycles.	-/w	-/w	$0 \dots + (2^{16}) - 1$
47:32	Configurable step pulse length for SD_CH2 in terms of 25MHz clock cycles.	-/w	-/w	$0 \dots + (2^{16}) - 1$

Table 158: MFC IO Register 33 – SD_STEPLength

Note Maximum step length: The individual step pulse length t_{STEP_PULSE} [s] must be lower than the time t_{STEP} [s] between step pulses to actually see step pulses. The condition $t_{STEP_PULSE} < t_{STEP}$ must be ensured by the application. Also refer to Section 7.14 for more details and formulas for calculation.

7.3.4.17 Register 34 – SD_DELAY

Bit	Description	ECAT	PDI	Range [Unit]
15:0	Configurable step-to-direction delay for SD_CH0 in terms of 25MHz clock cycles.	-/w	-/w	$0 \dots + (2^{16}) - 1$
31:16	Configurable step-to-direction delay for SD_CH1 in terms of 25MHz clock cycles.	-/w	-/w	$0 \dots + (2^{16}) - 1$
47:32	Configurable step-to-direction delay for SD_CH2 in terms of 25MHz clock cycles.	-/w	-/w	$0 \dots + (2^{16}) - 1$

Table 159: MFC IO Register 34 – SD_DELAY

Note Step-to-direction delay is the delay between the first step pulse after a change of the direction.

7.3.4.18 Register 35 – SD_CFG

Bit	Description	ECAT	PDI
0	0/1: 0 = enabled, 1 = disabled SD_CH0	-/w	-/w
1	0 = generate N pulses based on SD_CH0_STEPTARGET register value 1 = continuous mode	-/w	-/w
2	S0 and S0n step pulse signal polarity	-/w	-/w
3	D0 and D0n direction signal polarity	-/w	-/w
4	1 = clears SD_CH0_STEP_COUNT, user needs to set it back to 0 afterwards	-/w	-/w
5	0/1: 0 = normal step pulses, 1 = toggle mode	-/w	-/w
6	1 = use SD_CH0_NEXTSR for SD_CH0_STEPRATE on compare event	-/w	-/w
7	reserved	-/w	-/w
8	0/1: 0 = enabled, 1 = disabled SD_CH1	-/w	-/w
9	0 = generate N pulses based on SD_CH1_STEPTARGET register value 1 = continuous mode	-/w	-/w
10	S1 and S1n step pulse signal polarity	-/w	-/w
11	D1 and D1n direction signal polarity	-/w	-/w
12	1 = clears SD_CH1_STEP_COUNT, user needs to set it back to 0 afterwards	-/w	-/w
13	0/1: 0 = normal step pulses, 1 = toggle mode	-/w	-/w
14	1 = use SD_CH1_NEXTSR for SD_CH1_STEPRATE on compare event	-/w	-/w
15	reserved	-/w	-/w
16	0/1: 0 = enabled, 1 = disabled SD_CH2	-/w	-/w
17	0 = generate N pulses based on SD_CH2_STEPTARGET register value 1 = continuous mode	-/w	-/w
18	S2 and S2n step pulse signal polarity	-/w	-/w
19	D2 and D2n direction signal polarity	-/w	-/w
20	1 = clears SD_CH2_STEP_COUNT, user needs to set it back to 0 afterwards	-/w	-/w
21	0/1: 0 = normal step pulses, 1 = toggle mode	-/w	-/w
22	1 = use SD_CH2_NEXTSR for SD_CH2_STEPRATE on compare event	-/w	-/w
23	reserved	-/w	-/w

Table 160: MFC IO Register 35 – SD_CFG

7.3.5 PWM Unit

7.3.5.1 Register 36 – PWM_CFG

Bit	Description	ECAT	PDI	Range [Unit]
11:0	PWM max count	-/w	-/w	$0 \dots +(2^{12}) - 1$
15:12	unused	-/w	-/w	
18:16	PWM ch0 chopper mode See Section 7.15 for more details.	-/w	-/w	
19	unused	-/w	-/w	
22:20	PWM ch1 chopper mode See Section 7.15 for more details.	-/w	-/w	
23	unused	-/w	-/w	
26:24	PWM ch2 chopper mode See Section 7.15 for more details.	-/w	-/w	
27	unused	-/w	-/w	
30:28	PWM ch3 chopper mode See Section 7.15 for more details.	-/w	-/w	
31	unused	-/w	-/w	
33:32	PWM alignment for all PWM channels	-/w	-/w	
39:34	unused	-/w	-/w	
47:40	Signal Polarities for all PWM channels Bit 40 = PWM low sides polarity Bit 41 = PWM high sides polarity Bit 42 = PWM AB pulses polarity Bit 43 = PWM B pulses polarity Bit 44 = PWM Center pulses polarity Bit 45 = PWM A pulses polarity Bit 46 = PWM Zero pulses polarity	-/w	-/w	
47	unused	-/w	-/w	
55:48	BBM low sides. Brake before make time in terms of 100MHz clock cycles for low side MOSFET control	-/w	-/w	$0 \dots +(2^8) - 1$
63:56	BBM high sides. Brake before make time in terms of 100MHz clock cycles for high side MOSFET control	-/w	-/w	$0 \dots +(2^8) - 1$

Table 161: MFC IO Register 36 – PWM_CFG

7.3.5.2 Register 37 – PWM1

Bit	Description	ECAT	PDI	Range [Unit]
11:0	PWM duty cycle (on time) for PWM1	-/w	-/w	$0 \dots + (2^{12}) - 1$
15:12	unused	-/w	-/w	

*Table 162: MFC IO Register 37 – PWM1***7.3.5.3 Register 38 – PWM2**

Bit	Description	ECAT	PDI	Range [Unit]
11:0	PWM duty cycle (on time) for PWM2	-/w	-/w	$0 \dots + (2^{12}) - 1$
15:12	unused	-/w	-/w	

*Table 163: MFC IO Register 38 – PWM2***7.3.5.4 Register 39 – PWM3**

Bit	Description	ECAT	PDI	Range [Unit]
11:0	PWM duty cycle (on time) for PWM3	-/w	-/w	$0 \dots + (2^{12}) - 1$
15:12	unused	-/w	-/w	

*Table 164: MFC IO Register 39 – PWM3***7.3.5.5 Register 40 – PWM4**

Bit	Description	ECAT	PDI	Range [Unit]
11:0	PWM duty cycle (on time) for PWM4	-/w	-/w	$0 \dots + (2^{12}) - 1$
15:12	unused	-/w	-/w	

*Table 165: MFC IO Register 40 – PWM4***7.3.5.6 Register 41 – PWM1_CNTRSHFT**

Bit	Description	ECAT	PDI	Range [Unit]
11:0	Shift value for PWM1 to shift PWM1 high side and low side signal edges with respect to the aligned PWM counter.	-/w	-/w	$0 \dots + (2^{12}) - 1$
15:12	unused	-/w	-/w	

Table 166: MFC IO Register 41 – PWM1_CNTRSHFT

7.3.5.7 Register 42 – PWM2_CNTRSHFT

Bit	Description	ECAT	PDI	Range [Unit]
11:0	Shift value for PWM2 to shift PWM2 high side and low side signal edges with respect to the aligned PWM counter.	-/w	-/w	$0 \dots + (2^{12}) - 1$
15:12	unused	-/w	-/w	

Table 167: MFC IO Register 42 – PWM2_CNTRSHFT

7.3.5.8 Register 43 – PWM3_CNTRSHFT

Bit	Description	ECAT	PDI	Range [Unit]
11:0	Shift value for PWM3 to shift PWM3 high side and low side signal edges with respect to the aligned PWM counter.	-/w	-/w	$0 \dots + (2^{12}) - 1$
15:12	unused	-/w	-/w	

Table 168: MFC IO Register 43 – PWM3_CNTRSHFT

7.3.5.9 Register 44 – PWM4_CNTRSHFT

Bit	Description	ECAT	PDI	Range [Unit]
11:0	Shift value for PWM4 to shift PWM4 high side and low side signal edges with respect to the aligned PWM counter.	-/w	-/w	$0 \dots + (2^{12}) - 1$
15:12	unused	-/w	-/w	

Table 169: MFC IO Register 44 – PWM4_CNTRSHFT

7.3.5.10 Register 45 – PWM_PULSE_B_PULSE_A

Bit	Description	ECAT	PDI	Range [Unit]
11:0	Programmable trigger pulse A value with respect to the common PWM counter.	-/w	-/w	$0 \dots + (2^{12}) - 1$
15:12	unused	-/w	-/w	
27:16	Programmable trigger pulse B value with respect to the common PWM counter.	-/w	-/w	$0 \dots + (2^{12}) - 1$
31:28	unused	-/w	-/w	

*Table 170: MFC IO Register 45 – PWM_PULSE_B_PULSE_A***7.3.5.11 Register 46 – PWM_PULSE_LENGTH**

Bit	Description	ECAT	PDI	Range [Unit]
7:0	Programmable pulse length for trigger pulse A, B, PWM start, and PWM center.	-/w	-/w	$0 \dots + (2^8) - 1$

Table 171: MFC IO Register 46 – PWM_PULSE_LENGTH

7.3.6 General Purpose I/Os

7.3.6.1 Register 47 – GPO

Bit	Description	ECAT	PDI	Range [Unit]
15:0	GPOx output values	-/w	-/w	
31:16	GPOx safe state (when emergency input pin MFC_NES = '0')	-/w	-/w	

Table 172: MFC IO Register 47 – GPO

Note Bits [31:24] are not available in -ES sample devices.

7.3.6.2 Register 48 – GPI

Bit	Description	ECAT	PDI	Range [Unit]
15:0	GPIx input values	r/-	r/-	

Table 173: MFC IO Register 48 – GPI

7.3.6.3 Register 49 – GPIO_CONFIG

Bit	Description	ECAT	PDI	Range [Unit]
15:0	Output enable configuration for the GPOx signals Disabled = tristated.	-/w	-/w	

Table 174: MFC IO Register 49 – GPIO_CONFIG

Note GPIO_CONFIG is not available in -ES sample devices.

7.3.7 DAC Unit

7.3.7.1 Register 50 – DAC_VAL

Bit	Description	ECAT	PDI	Range [Unit]
15:0	16 bit DAC value which is converted to a pseudorandom binary sequence at the DAC output pin	-/w	-/w	

Table 175: MFC IO Register 50 – DAC_VAL

7.3.8 IRQ Control Block

7.3.8.1 Register 51 – MFCIO_IRQ_CFG

Bit	Description	ECAT	PDI	Range [Unit]
0	ABN encoder unit N-channel event	-/w	-/w	
1	SD_CH0 target reached event	-/w	-/w	
2	SD_CH1 target reached event	-/w	-/w	
3	SD_CH2 target reached event	-/w	-/w	
4	SD_CH0 compare value event	-/w	-/w	
5	SD_CH1 compare value event	-/w	-/w	
6	SD_CH2 compare value event	-/w	-/w	
7	SPI new data available event	-/w	-/w	
8	I2C new data available event	-/w	-/w	
9	I2C transmit complete event	-/w	-/w	
10	I2C new data available event OR I2C transmit complete event	-/w	-/w	
11	Watchdog Timeout event	-/w	-/w	
12	PWM zero pulse event	-/w	-/w	
13	PWM center pulse event	-/w	-/w	
14	PWM A pulse event	-/w	-/w	
15	PWM B pulse event	-/w	-/w	
16	HV_OT_FLAG has been set	-/w	-/w	
17	BVOUT_OT_FLAG has been set	-/w	-/w	
18	BVOUT_SC_FL has been set	-/w	-/w	
19	B3V3_SC_FLAG has been set	-/w	-/w	
22:20	unused/reserved	-/w	-/w	
23	emergency input pin MFC_NES event	-/w	-/w	

Table 176: MFC IO Register 51 – MFCIO_IRQ_CFG

Note

This register is used for masking / enabling the different IRQ sources, which are or-ed together to set the common MFCIO_IRQ output signal. The MFCIO_IRQ is a dedicated package pin of TMC8462A, which can be connected to a local application controller.

7.3.8.2 Register 52 – MFCIO_IRQ_FLAGS

Bit	Description	ECAT	PDI	Range [Unit]
0	ABN encoder unit N-channel event flag	r/-	r/-	
1	SD_CH0 target reached event flag	r/-	r/-	
2	SD_CH1 target reached event flag	r/-	r/-	
3	SD_CH2 target reached event flag	r/-	r/-	
4	SD_CH0 compare value event flag	r/-	r/-	
5	SD_CH1 compare value event flag	r/-	r/-	
6	SD_CH2 compare value event flag	r/-	r/-	
7	SPI new data available event flag	r/-	r/-	
8	I2C new data available event flag	r/-	r/-	
9	I2C transmit complete event flag	r/-	r/-	
10	I2C new data available event OR I2C transmit complete event flag	r/-	r/-	
11	Watchdog Timeout event flag	r/-	r/-	
12	PWM zero pulse event flag	r/-	r/-	
13	PWM center pulse event flag	r/-	r/-	
14	PWM A pulse event flag	r/-	r/-	
15	PWM B pulse event flag	r/-	r/-	
16	HV_OT_FLAG	r/-	r/-	
17	BVOUT_OT_FLAG	r/-	r/-	
18	BVOUT_SC_FL	r/-	r/-	
19	B3V3_SC_FLAG	r/-	r/-	
22:20	unused/reserved	-/-	-/-	
23	emergency input pin MFC_NES event flag	r/-	r/-	

Table 177: MFC IO Register 52 – MFCIO_IRQ_FLAGS

Note

Reading this registers clears all flags.

7.3.9 Watchdog

7.3.9.1 Register 53 – WD_TIME

Bit	Description	ECAT	PDI	Range [Unit]
31:0	Watchdog time 32 bit/unsigned 0 = Watchdog off, > 0 = number of 25MHz clock cycles	-/w	-/w	$0 \dots + (2^{32}) - 1$

Table 178: MFC IO Register 53 – WD_TIME

7.3.9.2 Register 54 – WD_CFG

Bit	Description	ECAT	PDI	Range [Unit]
0	cfg_persistent 0 = The watchdog action ends when the next trigger event occurs 1 = A timeout situation can only be cleared by rewriting WD_TIME	-/w	-/w	
1	cfg_pdi_csn_enable 1 = Retrigger by positive edge on PDI_SPI_CSN	-/w	-/w	
2	cfg_mfc_csn_enable 1 = Retrigger by positive edge on MFC_CTRL_SPI_CSN	-/w	-/w	
3	cfg_sof_enable 1 = Retrigger by ETHERCAT start of frame	-/w	-/w	
4	cfg_in_edge 0 = Retrigger by input condition becoming false 1 = Retrigger by input condition becoming true	-/w	-/w	
6:5	unused/reserved	-/-	-/-	
7	cfg_wd_active 1 = Signals an active watchdog timeout	-/w	-/w	

Table 179: MFC IO Register 54 – WD_CFG

7.3.9.3 Register 55 – WD_OUT_MASK_POL

Bit	Description	ECAT	PDI	Range [Unit]
23:0	WD_OUT_POL, Polarity for outputs affected by watchdog action. each bit corresponds to one output line. The polarity describes the output level desired upon watchdog event.	-/w	-/w	
31:24	unused/reserved	-/-	-/-	
55:32	WD_OUT_MASK, Each bit corresponds to one output line. 0 = Output is not affected 1 = Output [i] becomes set to WD_OUT_POL[i] upon watchdog event.	-/w	-/w	
63:56	unused/reserved	-/-	-/-	

Table 180: MFC IO Register 55 – WD_OUT_MASK_POL

Note

See Section 7.19 for the detailed signal mapping of WD_OUT_MASK_POL.

7.3.9.4 Register 56 – WD_OE_POL

Bit	Description	ECAT	PDI	Range [Unit]
31:0	I/O Output enable level for outputs affected by watchdog action. Each bit corresponds to one output line. The polarity describes the OE setting desired upon watchdog action (1 = output, 0 = input).	-/w	-/w	

Table 181: MFC IO Register 56 – WD_OE_POL

7.3.9.5 Register 57 – WD_IN_MASK_POL

Bit	Description	ECAT	PDI	Range [Unit]
23:0	WD_IN_POL, Input signal levels for watchdog re-triggering. Each bit corresponds to one input line. The polarity describes the input level for signals selected by WD_IN_MASK required to re-trigger the watchdog timer.	-/w	-/w	
31:24	unused/reserved	-/-	-/-	
55:32	WD_IN_MASK, Each bit corresponds to one input line. 0 = Input is not selected 1 = Input I/O[i] must reach polarity WD_IN_POL[i] to re-trigger the watchdog timer.	-/w	-/w	
63:56	unused/reserved	-/-	-/-	

Table 182: MFC IO Register 57 – WD_IN_MASK_POL

Note

See Section 7.19 for the detailed signal mapping of WD_IN_MASK_POL.

7.3.9.6 Register 58 – WD_MAX

Bit	Description	ECAT	PDI	Range [Unit]
31:0	Peak value reached by watchdog timeout counter. Reset to 0 by writing to WD_TIME.	r/-	r/-	$0 \dots + (2^{32}) - 1$

Table 183: MFC IO Register 58 – WD_MAX

7.3.10 High Voltage Status and General Control

7.3.10.1 Register 59 – HV_ANA_STATUS

Bit	Description	ECAT	PDI	Range [Unit]
7:0	HVIO_OUTPUT_HV_DETECT, bit[i] = 1 = high voltage detected at HV output [i]	r/-	r/-	
15:8	HV_SHORT2GND_DETECT, bit[i] = 1 = short to ground detected at HV IO [i-8]	r/-	r/-	
23:16	HV_SHORT2VS_DETECT, bit[i] = 1 = high voltage detected at HV IO [i-16]	r/-	r/-	
24	HV_OT_FLAG	r/-	r/-	
25	B3V3_SC_FLAG	r/-	r/-	
26	BVOUT_SC_FLAG	r/-	r/-	
27	BVOUT_OT_FLAG	r/-	r/-	
31:28	unused/reserved	r/-	r/-	

Table 184: MFC IO Register 59 – HV_ANA_STATUS

7.3.10.2 Register 63 – SYNC1_SYNC0_EVENT_CNT

Bit	Description	ECAT	PDI	Range [Unit]
15:0	SYNC_OUT0 event counter value	r/-	r/-	$0 \dots + (2^{16}) - 1$
31:16	SYNC_OUT1 event counter value	r/-	r/-	$0 \dots + (2^{16}) - 1$

Table 185: MFC IO Register 63 – SYNC1_SYNC0_EVENT_CNT

Note Reading does not clear counters. Counters are running all the time and wrap when maximum count is reached.

Note Register 63 can only be read when mapped to the ECAT Process Data RAM. It cannot be read from the MCF CTRL SPI interface.

7.3.10.3 Register 64 – HVIO_CFG

Bit	Description	ECAT	PDI	Range [Unit]
7:0	HV_SLOPE_SLOW With these option bits set to 1, the output slope of the MFC_HV[i] pin can be slowed down.	-/w	-/w	
15:8	HV_WEAK_HIGH With these option bits set to 1, the high level driver strength of the MFC_HV[i-8] pin can be reduced.	-/w	-/w	
23:16	HV_WEAK_LOW With these option bits set to 1, the low level driver strength of the MFC_HV[i-16] pin can be reduced.	-/w	-/w	
27:24	HV_DIFF_INPUT_EN With these option bits set to 1, two of the MFC_HV inputs can be combined to a differential input pair. Bit 24 = 1 = MFC_HV3 & MFC_HV0 Bit 25 = 1 = MFC_HV4 & MFC_HV1 Bit 26 = 1 = MFC_HV5 & MFC_HV2 Bit 27 = 1 = MFC_HV7 & MFC_HV6	-/w	-/w	
31:28	unused/reserved	-/-	-/-	

*Table 186: MFC IO Register 64 – HVIO_CFG***Note**

This register can only be accessed from MFC CTRL SPI interface.
It cannot directly be accessed from ECAT master interface.
Nevertheless, the register content can be preloaded from SII EEPROM at startup.
Therefore, see Section 7.4.

7.3.10.4 Register 65 – BUCK_CONV_CFG

Bit	Description	ECAT	PDI	Range [Unit]
1:0	B3V3_SAW_FREQ 3.3V switching regulator switching frequency (nominal values) 0 : 250kHz 1 : 125kHz 2 : 500kHz 3 : 1MHz	-/w	-/w	
3:2	B3V3_FB_AMPL 3.3V switching regulator voltage error feedback amplification 0 : 100% 1 : 150% 2 : 200% 3 : 50%	-/w	-/w	
5:4	B3V3_FB_CAP 3.3V switching regulator dampening of voltage error feedback 0 : 100% 1 : 150% 2 : 200% 3 : 50%	-/w	-/w	
6	B3V3_SC_DISABLE 3.3V switching regulator disable cycle-to-cycle overcurrent protection 0 : Protection enabled 1 : No protection	-/w	-/w	
7	unused/reserved	-/w	-/w	
9:8	BVOUT_SAW_FREQ Adjustable switching regulator switching frequency (nominal values) 0 : 250kHz 1 : 125kHz 2 : 500kHz 3 : 1MHz	-/w	-/w	
11:10	BVOUT_FB_AMPL Adjustable switching regulator voltage error feedback amplification 0 : 100% 1 : 150% 2 : 200% 3 : 50%	-/w	-/w	

Bit	Description	ECAT	PDI	Range [Unit]
13:12	BVOUT_FB_CAP Adjustable switching regulator dampening of voltage error feedback 0 : 100% 1 : 150% 2 : 200% 3 : 50%	-/w	-/w	
14	BVOUT_SC_DISABLE Adjustable switching regulator disable cycle-to-cycle overcurrent protection 0 : Protection enabled 1 : No protection	-/w	-/w	
15	BVOUT_DISABLE Disable adjustable switching regulator 0 : Switching regulator enabled 1 : Switching regulator disabled	-/w	-/w	

Table 187: MFC IO Register 65 – BUCK_CONV_CFG

Note

This register can only be accessed from MFC CTRL SPI interface. It cannot directly be accessed from ECAT master interface. Nevertheless, the register content can be preloaded from SII EEPROM at startup. Therefore, see Section 7.4.

7.3.11 Application Layer Control

7.3.11.1 Register 66 – AL_OVERRIDE

Bit	Description	ECAT	PDI	Range [Unit]
0	0 = no override 1 = override AL state	-/w	-/w	
7:1	unused/reserved	-/-	-/-	

Table 188: MFC IO Register 66 – AL_OVERRIDE

Note

The bit controls override configuration of the 24 MFC IO output ports regarding the output port availability with respect to the actual EtherCAT Slave Controller's AL state.

Typically, in an EtherCAT slave the output ports are only available/active when AL state = "OP" (operational). If the override bit is set, the AL state is ignored and the MFC IO ports are fully available via the MFC IO Control Interface.

The ABN functional block, IRQ configuration, Watchdog block are not affected by this configuration option since they only have input ports/signals.

! This register can only be accessed from MFC IO Control Interface. It cannot be accessed from ECAT master side.

The input ports are always readable via the MFC IO Control Interface.

When an input port is configured to be accessed by the EtherCAT master, it can only be read when the EtherCAT state machine is in safe-operational state or operational state.

When an output port/value is configured to be controlled by the EtherCAT master, this is only possible when the EtherCAT state machine is in operational state because. This is defined in the EtherCAT standard.

7.4 SII EEPROM MFC IO Block Parameter Map

This section describes the part of the EEPROM content and XML/ESI file that is used to configure the MFC IO block.

MFC IO configuration data is automatically loaded at startup from EEPROM to the [ESC Parameter RAM](#) starting at address 0x0580 of the the ESC register set. Therefore, this configuration data has to be of **Category 1**.

When a **Category 1** block is present in the EEPROM at address 0080_h, the EEPROM configuration is automatically loaded at power up of the TMC8462A. It is used for setting up the basic TMC8462A EtherCAT related features.

The configuration can also later be changed during operation via PDI access or via ECAT master access to the TMC8462A memory starting at 0580_h. The memory at address 0580_h corresponds to the beginning of the category data at EEPROM address 0084_h.

Note The MFC IO block parameters and register can be mapped into the the ESC Process Data RAM. For some applications and combinations it is possible to use these registers as cyclic data within a SyncManager. This is not possible for all registers and combinations and depends on the use case!

Note The EEPROM content starting at address 0084_h to address 0103_h (128 bytes) will be loaded into the EtherCAT slave controllers parameter memory at address range 0580_h to 05FF_h.
If the category is shorter than 128 bytes, only the amount of data specified by 'Category data size' is copied with the remaining bytes being reset to 0.

Address in EEPROM	Address in ESC RAM	Group	Function
0080 _h	-	Category header (Lo)	01 _h
0081 _h	-	Category header (Hi)	00 _h
0082 _h	-	Category data size in words (Lo)	31 _h (for the full MFCIO block configuration vector)
0083 _h	-	Category data size in words (Hi)	00 _h
0084 _h	0580 _h	Crossbar configuration	MFCIO00 Configuration (See Section 7.5)
0085 _h	0581 _h	Crossbar configuration	MFCIO01 Configuration
0086 _h	0582 _h	Crossbar configuration	MFCIO02 Configuration
0087 _h	0583 _h	Crossbar configuration	MFCIO03 Configuration
0088 _h	0584 _h	Crossbar configuration	MFCIO04 Configuration
0089 _h	0585 _h	Crossbar configuration	MFCIO05 Configuration

008A _h	0586 _h	Crossbar configuration	MFCIO06 Configuration
008B _h	0587 _h	Crossbar configuration	MFCIO07 Configuration
008C _h	0588 _h	Crossbar configuration	MFCIO08 Configuration
008D _h	0589 _h	Crossbar configuration	MFCIO09 Configuration
008E _h	058A _h	Crossbar configuration	MFCIO10 Configuration
008F _h	058B _h	Crossbar configuration	MFCIO11 Configuration
0090 _h	058C _h	Crossbar configuration	MFCIO12 Configuration
0091 _h	058D _h	Crossbar configuration	MFCIO13 Configuration
0092 _h	058E _h	Crossbar configuration	MFCIO14 Configuration
0093 _h	058F _h	Crossbar configuration	MFCIO15 Configuration
0094 _h	0590 _h	Crossbar configuration	MFC_HV0 Configuration
0095 _h	0591 _h	Crossbar configuration	MFC_HV1 Configuration
0096 _h	0592 _h	Crossbar configuration	MFC_HV2 Configuration
0097 _h	0593 _h	Crossbar configuration	MFC_HV3 Configuration
0098 _h	0594 _h	Crossbar configuration	MFC_HV4 Configuration
0099 _h	0595 _h	Crossbar configuration	MFC_HV5 Configuration
009A _h	0596 _h	Crossbar configuration	MFC_HV6 Configuration
009B _h	0597 _h	Crossbar configuration	MFC_HV7 Configuration
009C _h	0598 _h	HVIO configuration	Slow Slope (See section 7.6)
009D _h	0599 _h	HVIO configuration	Weak High
009E _h	059A _h	HVIO configuration	Weak Low
009F _h	059B _h	HVIO configuration	Differential input
00A0 _h	059C _h	Switching Regulator configuration	3.3V switching regulator (See section 7.7)
00A1 _h	059D _h	Switching Regulator configuration	Adjustable switching regulator
00A2 _h	059E _h	Memory block configuration	Memory block 0 start address Low Byte (See section 7.8)
00A3 _h	059F _h	Memory block configuration	Memory block 0 start address High Byte
00A4 _h	05A0 _h	Memory block configuration	Memory block 1 start address Low Byte
00A5 _h	05A1 _h	Memory block configuration	Memory block 1 start address High Byte
00A6 _h	05A2 _h	MFC register configuration	ENC_MODE (W)
00A7 _h	05A3 _h	MFC register configuration	ENC_STATUS (R)

00A8 _h	05A4 _h	MFC register configuration	X_ENC (W)
00A9 _h	05A5 _h	MFC register configuration	X_ENC (R)
00AA _h	05A6 _h	MFC register configuration	ENC_CONST (W)
00AB _h	05A7 _h	MFC register configuration	ENC_LATCH (R)
00AC _h	05A8 _h	MFC register configuration	SPI_RX_DATA (R)
00AD _h	05A9 _h	MFC register configuration	SPI_TX_DATA (W)
00AE _h	05AA _h	MFC register configuration	SPI_CONF (W)
00AF _h	05AB _h	MFC register configuration	SPI_STATUS (R)
00B0 _h	05AC _h	MFC register configuration	SPI_LENGTH (W)
00B1 _h	05AD _h	MFC register configuration	SPI_TIME (W)
00B2 _h	05AE _h	MFC register configuration	I2C_TIMEBASE (W)
00B3 _h	05AF _h	MFC register configuration	I2C_CONTROL (W)
00B4 _h	05B0 _h	MFC register configuration	I2C_STATUS (R)
00B5 _h	05B1 _h	MFC register configuration	I2C_ADDRESS (W)
00B6 _h	05B2 _h	MFC register configuration	I2C_DATA_R (R)
00B7 _h	05B3 _h	MFC register configuration	I2C_DATA_W (W)
00B8 _h	05B4 _h	MFC register configuration	SD_CH0_STEPRATE (W)
00B9 _h	05B5 _h	MFC register configuration	SD_CH1_STEPRATE (W)
00BA _h	05B6 _h	MFC register configuration	SD_CH2_STEPRATE (W)
00BB _h	05B7 _h	MFC register configuration	SD_CH0_STEPCOUNT (R)
00BC _h	05B8 _h	MFC register configuration	SD_CH1_STEPCOUNT (R)
00BD _h	05B9 _h	MFC register configuration	SD_CH2_STEPCOUNT (R)
00BE _h	05BA _h	MFC register configuration	SD_CH0_STEPTARGET (W)
00BF _h	05BB _h	MFC register configuration	SD_CH1_STEPTARGET (W)
00C0 _h	05BC _h	MFC register configuration	SD_CH2_STEPTARGET (W)
00C1 _h	05BD _h	MFC register configuration	SD_CH0_COMPARE (W)
00C2 _h	05BE _h	MFC register configuration	SD_CH1_COMPARE (W)
00C3 _h	05BF _h	MFC register configuration	SD_CH2_COMPARE (W)
00C4 _h	05C0 _h	MFC register configuration	SD_CH0_NEXTSR (W)
00C5 _h	05C1 _h	MFC register configuration	SD_CH1_NEXTSR (W)
00C6 _h	05C2 _h	MFC register configuration	SD_CH2_NEXTSR (W)
00C7 _h	05C3 _h	MFC register configuration	SD_STEPLength (W)
00C8 _h	05C4 _h	MFC register configuration	SD_DELAY (W)

00C9 _h	05C5 _h	MFC register configuration	SD_CFG (W)
00CA _h	05C6 _h	MFC register configuration	PWM_CFG (W)
00CB _h	05C7 _h	MFC register configuration	PWM1 (W)
00CC _h	05C8 _h	MFC register configuration	PWM2 (W)
00CD _h	05C9 _h	MFC register configuration	PWM3 (W)
00CE _h	05CA _h	MFC register configuration	PWM4 (W)
00CF _h	05CB _h	MFC register configuration	PWM1_CNTRSHFT (W)
00D0 _h	05CC _h	MFC register configuration	PWM2_CNTRSHFT (W)
00D1 _h	05CD _h	MFC register configuration	PWM3_CNTRSHFT (W)
00D2 _h	05CE _h	MFC register configuration	PWM4_CNTRSHFT (W)
00D3 _h	05CF _h	MFC register configuration	PWM_PULSE_B_PULSE_A (W)
00D4 _h	05D0 _h	MFC register configuration	PWM_PULSE_LENGTH (W)
00D5 _h	05D1 _h	MFC register configuration	GPO (W)
00D6 _h	05D2 _h	MFC register configuration	GPI (R)
00D7 _h	05D3 _h	MFC register configuration	GPIO_CONFIG (W)
00D8 _h	05D4 _h	MFC register configuration	DAC_VAL (W)
00D9 _h	05D5 _h	MFC register configuration	MFCIO_IRQ_CFG (W)
00DA _h	05D6 _h	MFC register configuration	MFCIO_IRQ_FLAGS (R)
00DB _h	05D7 _h	MFC register configuration	WD_TIME (W)
00DC _h	05D8 _h	MFC register configuration	WD_CFG (W)
00DD _h	05D9 _h	MFC register configuration	WD_OUT_MASK_POL (W)
00DE _h	05DA _h	MFC register configuration	WD_OE_POL (W)
00DF _h	05DB _h	MFC register configuration	WD_IN_MASK_POL (W)
00E0 _h	05DC _h	MFC register configuration	WD_MAX (R)
00E1 _h	05DD _h	MFC register configuration	HV_ANA_STATUS (R)
00E2 _h	05DE _h	Unused	Unused
00E3 _h	05DF _h	Unused	Unused
00E4 _h	05E0 _h	Unused	Unused
00E5 _h	05E1 _h	MFC register configuration	SYNC1_SYNC0_EVENT_CNT (R)

Table 189: EEPROM Parameter Map

7.5 SII EEPROM MFC IO Crossbar Mapping

The TMC8462A contains a full crossbar.

The 24 MFC IO pins (16x Low Voltage 3.3V MFC IO pins and 8x High Voltage MFC IO pins) of the TMC8462A can be freely assigned to any signal coming from or going to the MFC IO functional blocks.

Without initialization from the SII EEPROM on power up or later via PDI SPI/ECAT memory access during operation, all IOs are tri-stated.

Note

Certain output signals (e.g. PWM signals, DAC, ...) generate very short pulses (down to 10ns) which are faster than the slew rate of the HVIO output drivers. It is still possible to use this configuration, so that the user can evaluate if the application specific conditions allow to work directly with the HVIO outputs. Otherwise external signal conditioning is required.

One output signal can be mapped to multiple IO pins, for example to combine the driver strength of multiple pins. The configuration also allows a mapping of multiple pins to one input signal, but usually there is no reason for this configuration. When multiple pins are mapped to the same input signal, a logical OR operation is applied to all input pins.

Each IO pin has a dedicated configuration byte in the SII EEPROM and in the ESC's memory space within the [ESC Parameter RAM](#) to select the functional MFC IO block signal connected to the physical IO pin:

- MFCIO00 to MFCIO15: SII EEPROM 0084_h to 0093_h / ESC Parameter RAM from 0580_h to 058F_h
- MFC_HV0 to MFC_HV7²: SII EEPROM: 0094_h to 009B_h / ESC Parameter RAM from 0590_h to 0597_h

An overview over all configurable MFC IO block signals is given in Table 190.

Name	Function block	Description	Direction	Value dec.	Value hex.
ZERO	none	Disabled	-	0	00 _h
LOW	none	Static LOW output	output	1	01 _h
HGH	none	Static HIGH output	output	2	02 _h
TRI	none	Static tristate (Z) output	-	3	03 _h
A	ABN decoder	ABN_A signal	input	4	04 _h
An	ABN decoder	ABN_An signal (for differential inputs)	input	5	05 _h
B	ABN decoder	ABN_B signal	input	6	06 _h
Bn	ABN decoder	ABN_Bn signal (for differential inputs)	input	7	07 _h
N	ABN decoder	ABN_N signal	input	8	08 _h
Nn	ABN decoder	ABN_Nn signal (for differential inputs)	input	9	09 _h
SCK	SPI	SPI SCK signal	output	10	0A _h
SDI	SPI	SPI SDI signal	input	11	0B _h
SDO	SPI	SPI SDO signal	output	12	0C _h
CS0	SPI	SPI CS0 signal	output	13	0D _h

²MFC_HV0 to MFC_HV7 ≡ MFCIO16 to MFCIO23

CS1	SPI	SPI CS1 signal	output	14	0E _h
CS2	SPI	SPI CS2 signal	output	15	0F _h
CS3	SPI	SPI CS3 signal	output	16	10 _h
SCL	I ² C	I ² C SCL signal	output	17	11 _h
SDA	I ² C	I ² C SDA signal	in/out	18	12 _h
S0	Step/Direction	Step output channel 0	output	19	13 _h
D0	Step/Direction	Direction output channel 0	output	20	14 _h
S1	Step/Direction	Step output channel 1	output	21	15 _h
D1	Step/Direction	Direction output channel 1	output	22	16 _h
S2	Step/Direction	Step output channel 2	output	23	17 _h
D2	Step/Direction	Direction output channel 2	output	24	18 _h
S0n	Step/Direction	Inverted Step output channel 0	output	25	19 _h
D0n	Step/Direction	Inverted Direction output channel 0	output	26	1A _h
S1n	Step/Direction	Inverted Step output channel 1	output	27	1B _h
D1n	Step/Direction	Inverted Direction output channel 1	output	28	1C _h
S2n	Step/Direction	Inverted Step output channel 2	output	29	1D _h
D2n	Step/Direction	Inverted Direction output channel 2	output	30	1E _h
HS0	PWM	Channel 0 Highside signal	output	31	1F _h
LS0	PWM	Channel 0 Lowside signal	output	32	20 _h
HS1	PWM	Channel 1 Highside signal	output	33	21 _h
LS1	PWM	Channel 1 Lowside signal	output	34	22 _h
HS2	PWM	Channel 2 Highside signal	output	35	23 _h
LS2	PWM	Channel 2 Lowside signal	output	36	24 _h
HS3	PWM	Channel 3 Highside signal	output	37	25 _h
LS3	PWM	Channel 3 Lowside signal	output	38	26 _h
PULSE_A	PWM	PWM counter position A pulse	output	72	48 _h
PULSE_C	PWM	PWM counter center position pulse	output	73	49 _h
PULSE_B	PWM	PWM counter position B pulse	output	74	4A _h
PULSE_AB	PWM	PWM counter position A and B pulses	output	75	4B _h
PULSE_Z	PWM	PWM counter Zero position pulse	output	76	4C _h
GPIO	GPIO	General purpose input 0 signal	input	39	27 _h
GPI1	GPIO	General purpose input 1 signal	input	40	28 _h
GPI2	GPIO	General purpose input 2 signal	input	41	29 _h

GPI3	GPIO	General purpose input 3 signal	input	42	2A _h
GPI4	GPIO	General purpose input 4 signal	input	43	2B _h
GPI5	GPIO	General purpose input 5 signal	input	44	2C _h
GPI6	GPIO	General purpose input 6 signal	input	45	2D _h
GPI7	GPIO	General purpose input 7 signal	input	46	2E _h
GPI8	GPIO	General purpose input 8 signal	input	47	2F _h
GPI9	GPIO	General purpose input 9 signal	input	48	30 _h
GPI10	GPIO	General purpose input 10 signal	input	49	31 _h
GPI11	GPIO	General purpose input 11 signal	input	50	32 _h
GPI12	GPIO	General purpose input 12 signal	input	51	33 _h
GPI13	GPIO	General purpose input 13 signal	input	52	34 _h
GPI14	GPIO	General purpose input 14 signal	input	53	35 _h
GPI15	GPIO	General purpose input 15 signal	input	54	36 _h
GPO0	GPIO	General purpose output 0 signal	output	55	37 _h
GPO1	GPIO	General purpose output 1 signal	output	56	38 _h
GPO2	GPIO	General purpose output 2 signal	output	57	39 _h
GPO3	GPIO	General purpose output 3 signal	output	58	3A _h
GPO4	GPIO	General purpose output 4 signal	output	59	3B _h
GPO5	GPIO	General purpose output 5 signal	output	60	3C _h
GPO6	GPIO	General purpose output 6 signal	output	61	3D _h
GPO7	GPIO	General purpose output 7 signal	output	62	3E _h
GPO8	GPIO	General purpose output 8 signal	output	63	3F _h
GPO9	GPIO	General purpose output 9 signal	output	64	40 _h
GPO10	GPIO	General purpose output 10 signal	output	65	41 _h
GPO11	GPIO	General purpose output 11 signal	output	66	42 _h
GPO12	GPIO	General purpose output 12 signal	output	67	43 _h
GPO13	GPIO	General purpose output 13 signal	output	68	44 _h
GPO14	GPIO	General purpose output 14 signal	output	69	45 _h
GPO15	GPIO	General purpose output 15 signal	output	70	46 _h
DAC0	DAC	Pseudorandom 1-bit DAC signal	output	71	47 _h

Table 190: Crossbar configuration values

The following Figure 32 shows the crossbar with an example configuration. All input signals to the **MFC IO Incremental Encoder Block** are connected via external pins. In this case the first 6 low voltage MFC IOs are

used as inputs. No other functional MFC IO block is used in this example. The curly braces behind each MFC IO number contain the required configuration value in decimal numbers according to Table 190.

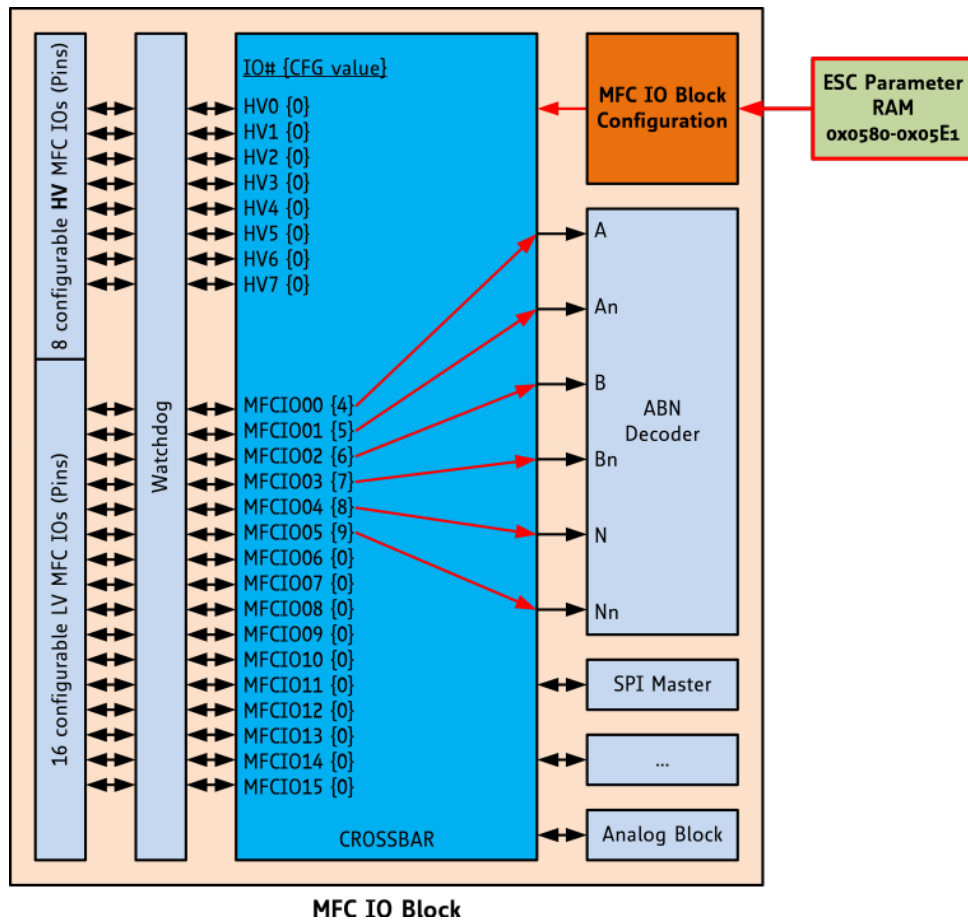

Figure 32: MFC IO Crossbar Example Configuration

7.6 SII EEPROM MFC IO High Voltage IO (HVIO) Configuration

The 8 HVIO pins have additional configuration options which can be set on power up from the SII EEPROM or later by SPI access to the memory.

The first three configuration bytes (Slope Slow, Weak High, Weak Low) each have one bit corresponding to one HV output:

Bit	Output
0	MFC_HV0
1	MFC_HV1
2	MFC_HV2
3	MFC_HV3
4	MFC_HV4
5	MFC_HV5
6	MFC_HV6
7	MFC_HV7

Table 191: Slope Slow/Weak High/WeakLow config

Slope Slow - 0598_h (SII EEPROM: 009C_h)

With this option set to 1, the output slope of the HVIO pins can be slowed down.

Weak High - 0599_h (SII EEPROM: 009D_h)

With this option set to 1, the high level driver strength of the HVIO pins can be reduced.

Weak Low - 059A_h (SII EEPROM: 009E_h)

With this option set to 1, the low level driver strength of the HVIO pins can be reduced.

Differential Input Enable - 059B_h (SII EEPROM: 009F_h)

With this option set to 1, two of the HVIO inputs can be combined to a differential input pair. Only the lower 4 bits are used to enable four specific pairs:

Bit	Positive input	Negative input
0	MFC_HV3	MFC_HV0
1	MFC_HV4	MFC_HV1
2	MFC_HV5	MFC_HV2
3	MFC_HV7	MFC_HV6

Table 192: Differential HV input configuration

The crossbar settings of MFC_HV3, MFC_HV4, MFC_HV5 and MFC_HV7 are ignored when they are used as a differential input.

7.7 SII EEPROM MFC IO Switching Regulator Configuration

3.3V switching regulator - 059C_h (SII EEPROM: 00A0_h)

Bit	Output
1:0	SAW_FREQ - Switching frequency (nominal values) 0 : 250kHz 1 : 125kHz 2 : 500kHz 3 : 1MHz
3:2	FB_AMPL - Voltage error feedback amplification 0 : 100% 1 : 150% 2 : 200% 3 : 50%
5:4	FB_CAP - Dampening of voltage error feedback 0 : 100% 1 : 150% 2 : 200% 3 : 50%
6	SC_DISABLE - Disable cycle-to-cycle overcurrent protection 0 : Protection enabled 1 : No protection

Table 193: Configuration bits for 3.3V switching regulator

Adjustable switching regulator - 059D_h (SII EEPROM: 00A1_h)

Bit	Output
1:0	SAW_FREQ - Switching frequency (nominal values) 0 : 250kHz 1 : 125kHz 2 : 500kHz 3 : 1MHz
3:2	FB_AMPL - Voltage error feedback amplification 0 : 100% 1 : 150% 2 : 200% 3 : 50%
5:4	FB_CAP - Dampening of voltage error feedback 0 : 100% 1 : 150% 2 : 200% 3 : 50%
6	SC_DISABLE - Disable cycle-to-cycle overcurrent protection 0 : Protection enabled 1 : No protection

Bit	Output
7	DISABLE - Disable Switching regulator 0 : Switching regulator enabled 1 : Switching regulator disabled

Table 194: Configuration bits for adjustable switching regulator

7.8 SII EEPROM MFC IO Memory Block Mapping

The MFC registers can be mapped to specific PDRAM memory areas to allow EtherCAT access (= accessible by the EtherCAT master), such that data is directly mirrored between each MFC register and the assigned PDRAM memory location. This allows the operation with a less powerful application processor or even without an application processor at all in Device Emulation mode.

The registers are dynamically mapped to one of two memory blocks:

- Memory Block 0 is used for write-registers (data direction: EtherCAT master -> MFC register)
- Memory Block 1 is used for read-registers (data direction: MFC register -> EtherCAT master).

The start address of each memory block can be configured to be anywhere in the PDRAM area (1000_h to $(4FFF_h - \text{blocksize})$).

The lengths of the two memory blocks depend on the selected registers that are mapped into the PDRAM. Extra care should be taken that the blocks do not overlap each other, that they do not overlap with other process data in the DPRAM, and that the memory blocks' start addresses are not too close at $4FFF_h$.

Memory Block 0 base address $059F_h:059E_h$ (SII EEPROM: $00A3_h:00A2_h$)

The start address of the block that all write registers of the MFC are mapped into.

Address $059F_h$ contains the upper byte of the start address. Allowed values: $10_h \dots 4F_h$

Address $059E_h$ contains the lower byte of the start address. Allowed values: $00_h \dots FF_h$

Memory Block 1 base address $05A1_h:05A0_h$ (SII EEPROM: $00A5_h:00A4_h$)

The start address of the block that all read registers of the MFC are mapped into.

Address $059F_h$ contains the upper byte of the start address. Allowed values: $10_h \dots 4F_h$

Address $059E_h$ contains the lower byte of the start address. Allowed values: $00_h \dots FF_h$

MFC registers are mapped in a defined order into the PDRAM.

When a register is mapped to the PDRAM its memory address depends on the other enabled registers with a lower register number.

The start address of any enabled register will be a multiple of 4 bytes from the start address of the memory block.

Between registers that are not a multiple of 4 bytes, a gap is left that is not transferred from the MFC IO block to the ESC RAM.

These gaps must be filled up with padding bytes.

NO padding is needed if the last register ends at an address not equal to a multiple of 4 bytes. This is especially required when using a Sync Manager on top of the memory manager address range in the ESC RAM. Otherwise, the Sync Manager will not trigger since the last byte is never actually written.

Example: if a 2-byte register, an 8-byte register, a 1-byte register, and a 4-byte register are enabled in a memory block starting at 2000_h , the memory is used as shown in the following table:

Register	End Address	Start Address
Reg. 1 (2 byte)	2001_h	2000_h
<i>Padding</i>	2003_h	2002_h
Reg. 2 (8 byte)	$200B_h$	2004_h
Reg. 3 (1 byte)	$200C_h$	$200C_h$
<i>Padding</i>	$200F_h$	$200D_h$
Reg. 4 (4 byte)	2013_h	2010_h

Table 195: Register mapping example

For the actual register sizes please refer to Table 124 in Section 7.2.

7.8.1 Sync Manager Configuration and Memory Blocks

Sync Managers can be used and configured on top of the memory managers for read (inputs) and write registers (outputs).

The base length of the Sync Manager is the size of the memory manager address range including the padding bytes.

For the example given in the table above the Sync Manager would have 6 PDOs and a size of 20 bytes.

Again, NO padding is needed if the last register ends at an address not equal to a multiple of 4 bytes. This is especially required when using a Sync Manager on top of the memory manager address range in the ESC RAM. Otherwise, the Sync Manager will not trigger since the last byte is never actually written.

7.9 SII EEPROM MFC IO Register Configuration

All MFC registers are accessible via the [MFC IO Control SPI Interface](#). Alternatively they can be mapped into the ESC's Process Data RAM to allow access via EtherCAT. In this case the mapped registers can only be written by the EtherCAT master. But they can still be read via MFC IO Control SPI Interface.

The transfer of all enabled registers is performed in one access. To enable the data update at certain times only, a shadow register is used for every MFC register. The exact point in time when the actual data transfer occurs (from the shadow register into a write register or from a read register into the shadow register) is based on the chosen [trigger source](#).

There is one configuration byte in the SII EEPROM (and [ESC Parameter RAM](#) respectively) for each MFC block register. The configuration for all registers has the same options:

Bit	Description
3:0	Trigger Source
4	Enable RAM transfer 0 : disabled , register access only from MCU via MFC CTRL SPI 1 : enabled , read and write access via EtherCAT, readable by MCU via MFC CTRL SPI
7:5	Unused

Table 196: Register configuration byte

Trigger Source hex.	Trigger Source Name	Description
0 _h	Trigger always	shadow register is transparent
1 _h	SYNC0 signal	distributed clocks sync pulse 0 (0->1)
2 _h	SYNC1 signal	distributed clocks sync pulse 1 (0->1)
3 _h	LATCH0 signal	distributed clocks latch input 0 (0->1)
4 _h	LATCH1 signal	distributed clocks latch input 1 (0->1)
5 _h	EtherCAT start of frame (SOF)	Start of frame on EtherCAT bus
6 _h	EtherCAT end of frame (EOF)	End of frame on EtherCAT bus
7 _h	PDI SPI nCS=0 (Chip Select)	Falling edge on PDI_SPI_CSN pin
8 _h	PDI SPI nCS=1 (Chip Deselect)	Rising edge on PDI_SPI_CSN pin
9 _h	MFC SPI nCS=0 (Chip Select)	Falling edge on MFC_CTRL_SPI_CSN pin
A _h	MFC SPI nCS=1 (Chip Deselect)	Rising edge on MFC_CTRL_SPI_CSN pin
B _h	Trigger before register is handled	Before data is copied to/from RAM by Memory Bridge
C _h	Trigger after register was handled	After data is copied to/from RAM by Memory Bridge
D _h	Trigger on PWM counter = 0	Transfer at the zero pulse of the MFC PWM unit
E _h	Trigger never	no data is transferred, can be used for debugging
F _h	Trigger always	shadow register is transparent

Trigger Source hex.	Trigger Source Name	Description
----------------------------	----------------------------	--------------------

Table 197: Trigger source descriptions

7.10 MFC IO ESI/XML Configuration Block

This example shows the part of the ESI/XML configuration file for EtherCAT slaves used to configure the MFC IO block directly out of the EEPROM (at power-up or reset). Therefore, the configuration block must be classified as category 1 information within the EEPROM.

Another way to configure the MFC IO block is to directly write via PDI or ECAT interface to the EtherCAT registers at 0x0580 to 0x05E1 (ESC Parameter RAM).

An easy way to generate the configuration data string that is used in this XML structure is to use the wizard included in the TMCL-IDE. See also section [ESI Configuration Wizard](#).

```

1 <Eeprom>
  <ByteSize>2048</ByteSize>
3
  <!-- Mandatory configuration bytes according to EtherCAT standard-->
5  ConfigData>00000000000000000000...</ConfigData>
7
  <!-- MFC IO Configuration vector must be of category 1.-->
  <!-- It will be loaded into registers 0x0580...0x05E1 -->
  <!-- during EEPROM loading at startup. -->
  <Category>
11    <CatNo>1</CatNo>
    <Data>0000000000000000000000000000000000000000000000000000000000000000
13      0000000000000000000000000000000000000000000000000000000000000000
      0000000000000000000000000000000000000000000000000000000000000000
15      0000000000000000000000000000000000000000000000000000000000000000
      00000000
17    </Data>
  </Category>
19 </Eeprom>

```

Figure 33: MFC IO ESI/XML Configuration Block

Note

The zeros in the example above are just placeholders and must be adapted to the respective configuration.

See the available application notes and examples on www.trinamic.com for more information.

7.11 MFC IO Incremental Encoder Block

This function block provides input pins for incremental encoder signals (two quadrature signals and one index signal) with differential option. It has a large range of resolution settings, allowing the use of many different encoders without requiring extra calculations.

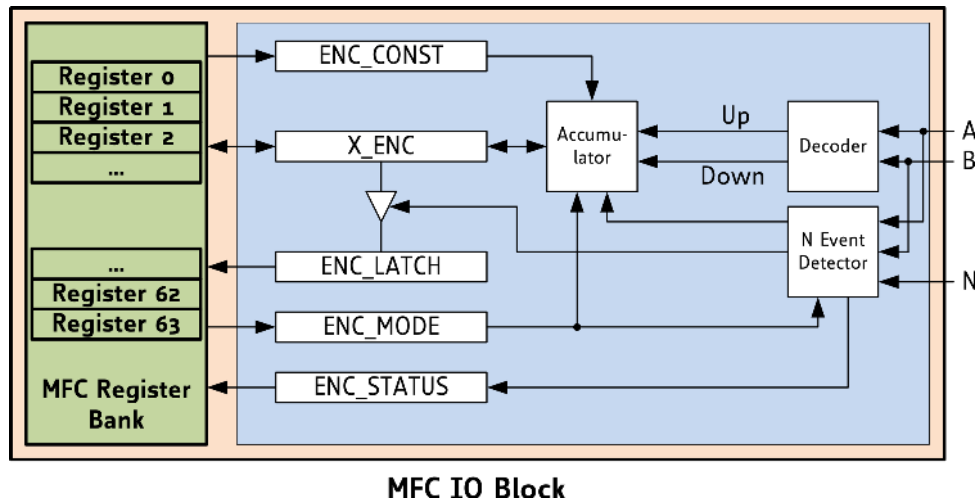

Figure 34: MFC IO Incremental Encoder Unit

Encoder Block Configuration Configuration of the Incremental Encoder Block is done via the [ENC_MODE register](#). Polarities, index event handling, clear and latch options, and prescaler mode can be configured.

N Event Flag The LSB in the [ENC_STATUS register](#) shows that an N event has occurred since the last read access to this register. The flag is cleared on a read access.

Encoder Constant The encoder constant ENC_CONST is added to or subtracted from the encoder counter on each polarity change of the quadrature signals AB of the incremental encoder. The encoder constant ENC_CONST represents a signed fixed point number (16.16) to facilitate the generic adaption between motors and encoders. In decimal mode, the lower 16 bits represent a number between 0 and 9999. For stepper motors equipped with incremental encoders the fixed number representation allows very comfortable parametrization. Additionally, mechanical gearing can easily be taken into account. Negating the sign of ENC_CONST allows inversion of the counting direction to match motor and encoder direction. The encoder constant can be configured in the [ENC_CONST register](#).

Examples:

- Encoder factor of 1.0:
ENC_CONST = 0x0001.0x0000 = FACTOR.FRACTION
- Encoder factor of -1.0:
ENC_CONST = 0xFFFF.0x0000
This is the two's complement of 0x00010000. It equals $(2^{16} - (\text{FACTOR} + 1)) \cdot (2^{16} - \text{FRACTION})$
- Decimal mode encoder factor 25.6:
ENC_CONST = 00025.6000 = 0x0019.0x1770 = FACTOR.DECIMALS
- Decimal mode encoder factor -25.6:
ENC_CONST = 0xFFE6.4000 = 0xFFE6.0x0FA0.
This equals $(2^{16} - (\text{FACTOR} + 1)) \cdot (10000 - \text{DECIMALS})$

Encoder Position The encoder counter ENC_X holds the current encoder position ready for read out. Different modes concerning handling of the signals A, B, and N take into account active low and active high signals as found with different types of encoders.

The current encoder position can be read from [MFC IO register 3](#).

The encoder position can also be overwritten and set to a specific value. The current encoder position can be written to [MFC IO register 2](#).

Latched Encoder Position When either `clr_cont` or `clr_once` are set in the [ENC_MODE register](#), the current encoder position from ENC_X is latched into [MFC IO register 5](#) on an active N event.

7.12 MFC IO SPI Master Block

The SPI Master Unit provides an interface for up to four SPI slaves with a theoretically unlimited datagram length using multiple accesses.

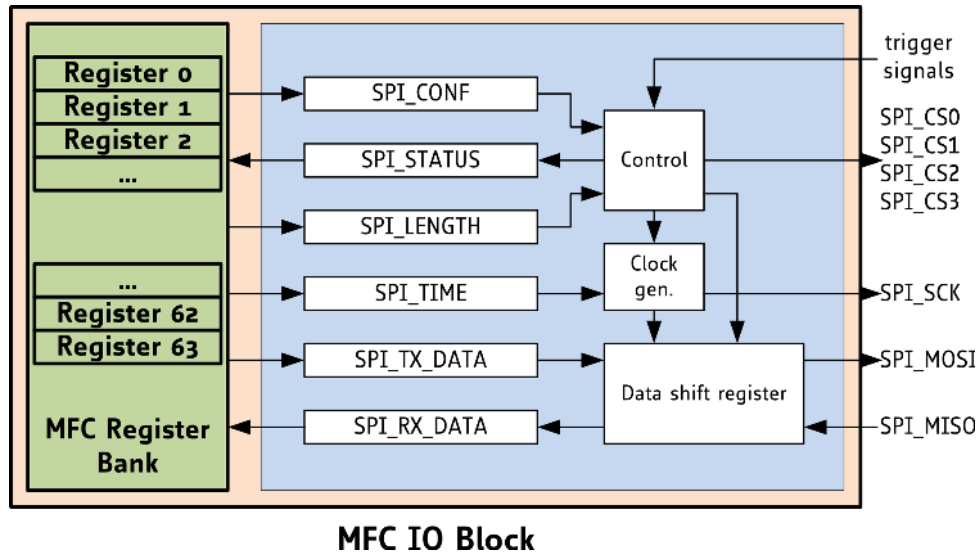

Figure 35: Block structure of SPI Master Unit

The basic configuration requires setting the SPI frequency/bit length, the datagram length and the SPI mode (clock polarity and phase). Extended settings are a special start-of-transmission trigger linked to the PWM unit, the bit order, selection of one of the four SPI slaves and datagram length extension.

SPI_RX_DATA – Received Data This register contains the received datagram after an SPI transfer. For SPI transfers with less than 64 bit, the upper bits of this register are unused.

SPI_TX_DATA – Data to transmit The data to be sent is written to this register. Unless configured differently in SPI_CONF Bits 10..8, writing to this register starts the SPI transfer. For SPI transfers with less than 64 bit, the upper bits of this register are unused.

SPI_CONF – SPI block configuration

- Bit 15 is the trigger bit that can be selected as transmission start trigger (see below).
- Bits 10..8 allow a configuration when the data transmission should start, they are interpreted as a 3 bit number:
 - In the reset configuration 0, the transmission always starts when data is written to the SPI_TX register.
 - The settings 1 to 5 link the start of the transmission to the PWM unit, allowing synchronization between the PWM cycle and for example a SPI ADC for current measurement. The trigger sources are the five PWM_PULSE signals that are also available on the MFCIO crossbar. Please refer to Section 7.15 for details about these pulses.
 - Setting 7 is a single shot trigger that starts only one transmission when Bit 15 of SPI_CONF is written to 1.
- Bit 6 and 5 define the clock polarity and phase of the SPI signals which define what the idle state of the SCK signal is and when output data is changed and when input data is sampled.

Clock polarity	Clock phase	SPI mode	MOSI change	MISO sample
0	0	0	SCK falling edge	SCK rising edge
0	1	1	SCK rising edge	SCK falling edge
1	0	2	SCK rising edge	SCK falling edge
1	1	3	SCK falling edge	SCK rising edge

Table 198: SPI mode configuration

- Bit 4 reverses the bit order in the transmission, the least significant bit of SPI_TX_DATA (Bit 0) is transmitted first, the least significant bit of SPI_RX_DATA is the first received bit, the most significant bit of SPI_TX_DATA is transmitted last and the most significant bit of SPI_RX_DATA is the last bit received.
- Bit 3 can be used for datagrams longer than 64 bit. With this bit set, the chip select line is held low after the transmission, allowing more transmissions in the same datagram. Before the last transmission, this bit must be set to 0 again so that the chip select line goes high afterwards, ending the datagram.
- Bits 1 and 0 define which chip select line (which slave) is used for the next transmission.

SPI_STATUS – SPI transfer status Bit 0 of this register is the Ready indicator for the SPI master unit. When this bit is set, a new transfer can be started. When this bit is 0 and the start of a new transfer is triggered, the trigger is ignored, the currently active transfer is finished but the new transfer is not started.

SPI_LENGTH – SPI datagram length This register defines the SPI datagram length in bits. Any length from 1 to 64 bits is possible.
 SPI datagram length (bits) = SPI_LENGTH+1

SPI_TIME – SPI bit duration This register defines the bit length and thus the SPI clock frequency. The duration of one SPI clock cycle can be calculated as $t_{SCK} = (4+(2*SPI_TIME))/25MHz = (4+(2*SPI_TIME))*40ns$, the SPI clock frequency is $f_{SCK} = 25MHz/(4+(2*SPI_TIME))$. The delay between the falling edge of CSN (becoming active) and the first SCK edge and the last SCK edge and the rising edge of CSN is always a half SCK clock cycle ($t_{SCK}/2$).

7.12.1 SPI Examples

TMC262 on SPI channel 0

This example shows the configuration of the SPI master unit for a TMC262 as SPI slave 0 and the transfer of data to the TMC262's DRVCONF register.

1. Use 3.125 MHz SPI clock ($25MHz/(4+(2*2)) = (25MHz/8)$)
`SPI_TIME <= 0x02`
2. Use 20 bit datagrams
`SPI_LENGTH <= 0x13`
3. Start on TX write, SPI-Mode 3, MSB first, single datagrams, Slave 0)
`SPI_CONF <= 0x0060`
4. Wait until SPI-Master is ready
`while (SPI_STATUS & 0x01 != 0x01)`

5. Write Data into TX register (e.g. TMC262 DRVCONF register, all 64bit are shown)
`SPI_TX_DATA <= 0x000000000000EF010`
6. Wait until SPI-Master is ready
`while (SPI_STATUS & 0x01 != 0x01)`
7. Read Data from RX register
`rxdatagram = SPI_RX_DATA`

Chain of 10 74xx595 shift registers used as 80 digital outputs (good example)

This example shows the transmission of a longer datagram, in this case 80 bits that are shifted into a chain of 74xx595 shift registers. The NCS of the SPI interface can be used as the storage clock of the 74xx595 to transfer the contents of the shift register into the storage register. The data that should be sent is 0x5555AAAA5555AAAA55AA.

It is recommended to split the data into two chunks of 40 bits each: 0x5555AAAA55 and 0x55AAAA55AA.

Configuration and first transmission

1. Use 6.25 MHz SPI clock (25MHz/(4+(2*0))) = (25MHz/4)
`SPI_TIME <= 0x00`
2. Use a 40 bit datagram
`SPI_LENGTH <= 0x28`
3. Start on TX write, SPI-Mode 3, MSB first, Keep CS low, Slave 0)
`SPI_CONF <= 0x0068`
4. Wait until SPI-Master is ready
`while (SPI_STATUS & 0x01 != 0x01)`
5. Write Data for the first 64 outputs into TX register
`SPI_TX_DATA <= 0x5555AAAA55`
6. Wait until SPI-Master is ready
`while (SPI_STATUS & 0x01 != 0x01)`
7. Start on TX write, SPI-Mode 3, MSB first, Drive CS high at the end, Slave 0)
`SPI_CONF <= 0x0060`
8. Write Data for the last 16 outputs into TX register
`SPI_TX_DATA <= 0x55AAAA55AA`
9. Wait until SPI-Master is ready
`while (SPI_STATUS & 0x01 != 0x01)`

Next transmission with inverted data

1. Start on TX write, SPI-Mode 3, MSB first, Keep CS low, Slave 0)
`SPI_CONF <= 0x0068`
2. Wait until SPI-Master is ready
`while (SPI_STATUS & 0x01 != 0x01)`
3. Write Data for the first 40 outputs into TX register
`SPI_TX_DATA <= 0xAAAA5555AA`
4. Wait until SPI-Master is ready
`while (SPI_STATUS & 0x01 != 0x01)`
5. Start on TX write, SPI-Mode 3, MSB first, Drive CS high at the end, Slave 0)
`SPI_CONF <= 0x0060`

6. Write Data for the last 40 outputs into TX register
`SPI_TX_DATA <= 0xAA5555AA55`
7. Wait until SPI-Master is ready
`while (SPI_STATUS & 0x01 != 0x01)`

Chain of 10 74xx595 shift registers used as 80 digital outputs (bad example)

This bad example is the same as the previous one but with the non-recommended datagram split of 64 bits + 16 bit. This requires more communication since not only the SPI_CONF register needs to be changed between the SPI_TX_DATA writes but also the SPI_LENGTH register changes every time.

Configuration and first transmission

1. Use 6.25 MHz SPI clock ($25\text{MHz}/(4+(2*0)) = (25\text{MHz}/4)$)
`SPI_TIME <= 0x00`
2. Use a 64 bit datagram
`SPI_LENGTH <= 0x3F`
3. Start on TX write, SPI-Mode 3, MSB first, Keep CS low, Slave 0)
`SPI_CONF <= 0x0068`
4. Wait until SPI-Master is ready
`while (SPI_STATUS & 0x01 != 0x01)`
5. Write Data for the first 64 outputs into TX register
`SPI_TX_DATA <= 0x5555AAAA5555AAAA`
6. Wait until SPI-Master is ready
`while (SPI_STATUS & 0x01 != 0x01)`
7. Use a 16 bit datagram (remaining outputs)
`SPI_LENGTH <= 0x0F`
8. Start on TX write, SPI-Mode 3, MSB first, Drive CS high at the end, Slave 0)
`SPI_CONF <= 0x0060`
9. Write Data for the last 16 outputs into TX register
`SPI_TX_DATA <= 0x55AA`
10. Wait until SPI-Master is ready
`while (SPI_STATUS & 0x01 != 0x01)`

Next transmission with inverted data

1. Use a 64 bit datagram
`SPI_LENGTH <= 0x3F`
2. Start on TX write, SPI-Mode 3, MSB first, Keep CS low, Slave 0)
`SPI_CONF <= 0x0068`
3. Wait until SPI-Master is ready
`while (SPI_STATUS & 0x01 != 0x01)`
4. Write Data for the first 64 outputs into TX register
`SPI_TX_DATA <= 0xAAAA5555AAAA5555`
5. Wait until SPI-Master is ready
`while (SPI_STATUS & 0x01 != 0x01)`

6. Use a 16 bit datagram (remaining outputs)
`SPI_LENGTH <= 0x0F`
7. Start on TX write, SPI-Mode 3, MSB first, Drive CS high at the end, Slave 0)
`SPI_CONF <= 0x0060`
8. Write Data for the last 16 outputs into TX register
`SPI_TX_DATA <= 0xAA55`
9. Wait until SPI-Master is ready
`while (SPI_STATUS & 0x01 != 0x01)`

7.13 MFC IO I2C Master Block

The TMC8462A I2C master allows accessing I2C slaves by writing and reading control and data registers instead of needing to take care of timing or even bit-banging through the GPIO block.

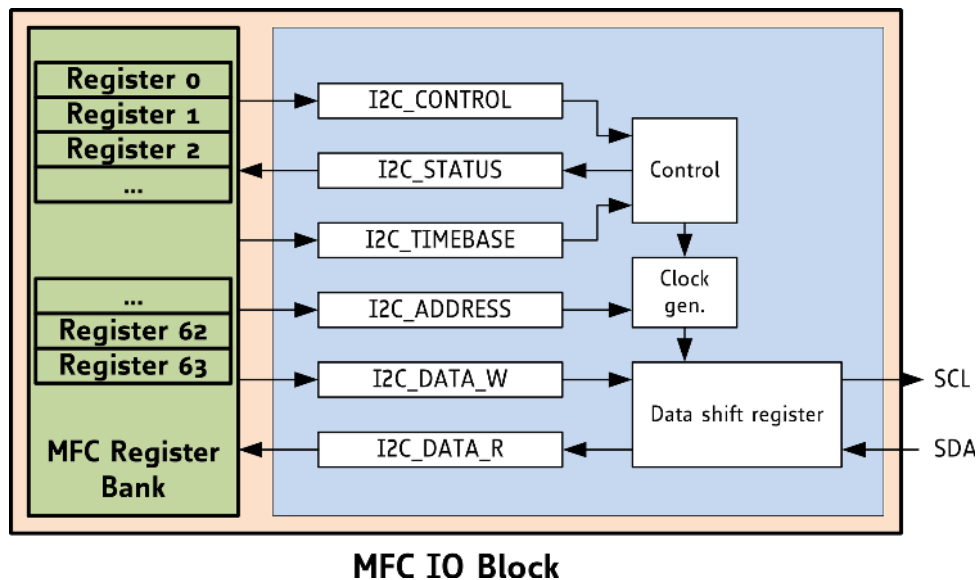

Figure 36: Block structure of SPI Master Unit

I2C_TIMEBASE – Bit duration in μs

This register determines the I2C clock frequency by setting the duration of a single bit. A setting of 0 disables communication, a setting of 1 results in bit duration of 1 μs , the maximum setting of 255 results in a bit duration of 255 μs .

I2C_CONTROL – Command register

There are 6 commands that allow full control of the I2C master block. Each command is represented by a single bit in this register.

Command byte	Bit in register	Command
0x20	5	Send Start Condition (also Repeated Start)
0x10	4	Send Stop Condition
0x08	3	Send Address (Content of Address register), incl. R/nW Bit
0x04	2	Send Data (Content of Data register)
0x02	1	receive Data and send ACK
0x01	0	receive Data and send NACK

Table 199: I2C control commands

I2C_STATUS – Status register

The status bits show the current transmission status either alone or in a combination of multiple bits.

Status bit	Description
7	Error Flag
6	Not Acknowledge received/sent
5	Acknowledge received/sent
4	Write to slave mode
3	Read from Slave mode
2	Transmit Address mode
1	Repeated Start condition sent
0	Start condition sent

Table 200: I2C status register bits

Bits 0 and 1 are set after command 0x20 was successfully executed, either if the I2C bus was idle or a start condition already has been sent.

A combination of Bits 2 to 6 indicates completion of an address or data cycle.

Bit 7 indicates an error during transmission. A stop condition should be sent to return to the idle state.

Status byte	Status
0x00	Idle
0x01	Start sent
0x02	Repeated Start sent
0x34	Write Address ACK
0x2C	Read Address ACK
0x54	Write Address NACK
0x4C	Read Address NACK
0xE4	Address Error
0x48	Read Data ACK sent
0x28	Read Data NACK sent
0x30	Write Data ACK
0x50	Write Data NACK
0xF0	Write Data Error
0xFF	General Error

Table 201: I2C status overview

I2C_ADDR – Address register with R/nW bit

This register contains the 7 bit address of the I2C slave and the single R(ead)/n(ot)W(rite) bit.

Bit	7	6	5	4	3	2	1	0
Function	A6	A5	A4	A3	A2	A1	A0	R/nW

Table 202: I2C Address register

I2C_DATA_R – Data register for received data

After a read command, this register contains the last read data byte.

I2C_DATA_W – Data register for data to transmit

The data byte that should be sent with the next write command is written to this register.

Basic usage An usual communication cycle is done by the following steps

1. Set the bit duration in μs in the I2C_TIMEBASE register (only required as configuration after reset or if a different speed is required).
2. Write 0x20 (Send Start Condition) to the I2C_CONTROL register.
3. Write the slave address and the R/nW bit to the I2C_ADDR register.
4. Write 0x80 (Send Address) to the I2C_CONTROL register.
5. Depending on the R/nW bit, either
 - Write 0x01 (Receive Data and send NACK) or 0x02 (Receive Data and send ACK) to I2C_CONTROL to receive data and send NACK or ACK.
 - Read the data from the I2C_DATA_R register.

or

- Write data to the I2C_DATA_W register.
- Write 0x04 (Send Data) to I2C_CONTROL to send the data.

This can be repeated as long as it is necessary.

6. Write 0x10 (Send Stop Condition) to the I2C_CONTROL register.

A repeated start condition, as it is required for slaves like EEPROMs, can be sent like the regular start condition by writing 0x20 to the I2C_CONTROL register at any required time.

7.13.1 I2C Example

This Example shows reading from an 24LC64 I2C EEPROM. The standard I2C address is configurable from 0x50 to 0x57 with 3 address pins. The address 0x50 is used for this example. The memory uses 13 bit addresses, so two memory address bytes are used. The memory address 0x1234 is used for this example.

1. Set I2C clock to 100kHz (10 μs)
I2C_TIMEBASE <= 0x0A
2. Send Start Condition
I2C_CONTROL <= 0x20
3. Write the slave address and the nW bit ((0x50 « 1) + 0 = 0xA0)
I2C_ADDR <= 0xA0
4. Send Address
I2C_CONTROL <= 0x80

5. Write upper byte of the memory address
I2C_DATA_W <= 0x12
6. Send Data
I2C_CONTROL <= 0x04
7. Write lower byte of the memory address
I2C_DATA_W <= 0x34
8. Send Data
I2C_CONTROL <= 0x04
9. Send Repeated-Start Condition
I2C_CONTROL <= 0x20
10. Write the slave address and the R bit $((0x50 \ll 1) + 1 = 0xA1)$
I2C_ADDR <= 0xA1
11. Command: Receive Data and send ACK
I2C_CONTROL <= 0x02
12. Read the data
databyte <= I2C_DATA_R
The last two steps can be repeated as long as it is necessary, for the last byte send a NACK instead:
13. Command: Receive Data and send NACK
I2C_CONTROL <= 0x01
14. Read the data
databyte <= I2C_DATA_R
15. Write 0x10 (Send Stop Condition) to the I2C_CONTROL register.

7.14 MFC IO Step and Direction Block

The MFC IO step & direction block allows for generation of defined step pulse frequencies along with a direction signal.

This is done by writing an accumulation constants to a register. Toggle of the MSB of the accumulation register value generates an internal step pulse of one internal clock cycle.

The direction signal is the MSB of the accumulation constant. Therefore, the sign of the accumulation constant defines the direction signal polarity. The step-to-direction timer (STP2DIR) takes care of possible external signal delay paths by programmable delay of the first step after write of accumulation constant. The pulse stretcher forms step and direction pulses of programmable length for adaption to external signal paths.

The step direction unit can either run in free running mode just generating step pulses with programmed frequency. Alternatively, it can generate a defined number of step pulses with programmed frequency. An interrupt output signal IRQ TARGET_REACHED indicates the reached target count of step pulses. TMC8462A has three independent step and direction channels.

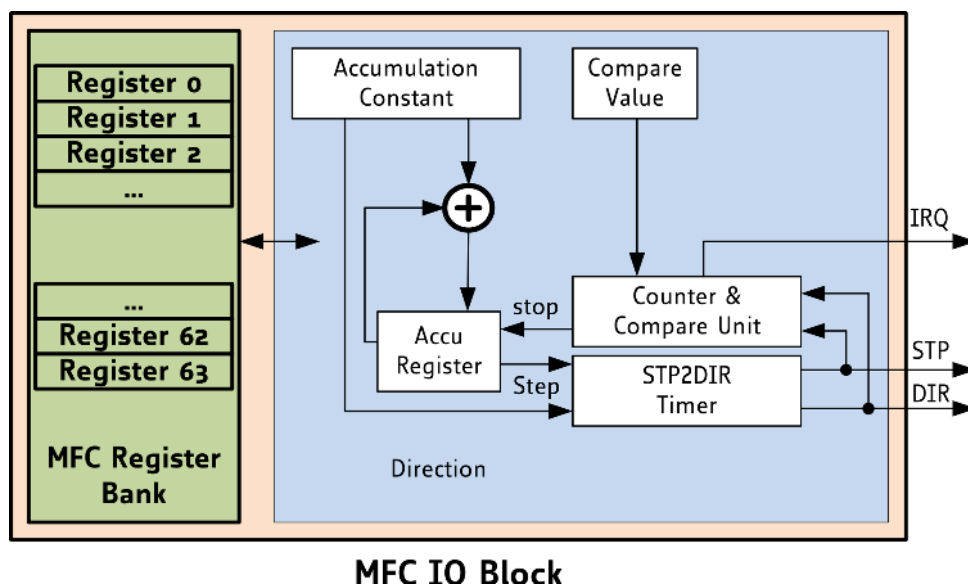

Figure 37: Block structure of the MFC IO Step and Direction Block

Step & Direction Signal Timing Write to the accumulation constant register starts step pulse generation. The first step pulse occurs after a time $t_{STEP1st}$. Following step pulses come after each t_{STEP} . The pulse length of the step pulses is t_{STEP_PULSE} . On change of direction by writing the accumulation constant with a constant of different sign, the first step pulse after write occurs after $t_{STP2DIR}$.

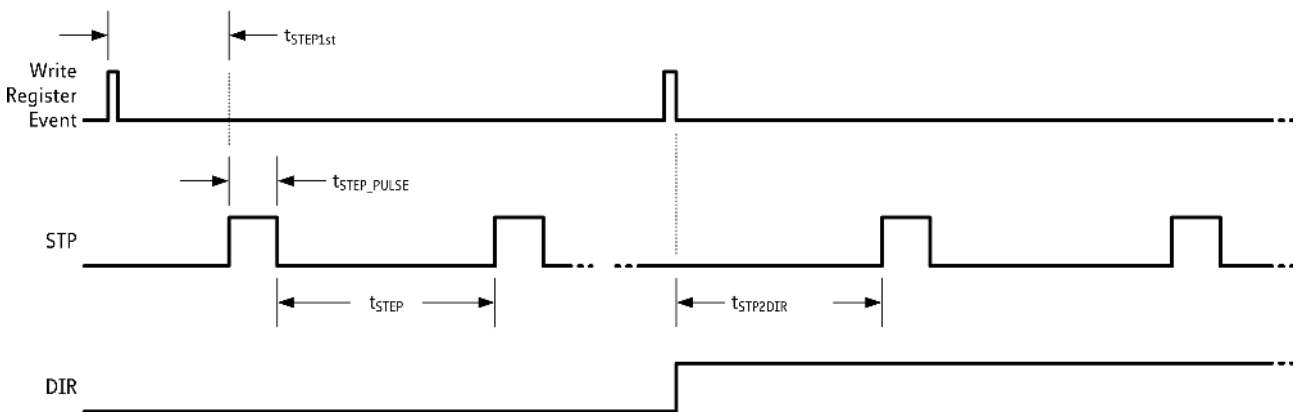

Figure 38: Step & Direction Signal Timing

Parameter	Value	Description / Function	Comment
f_{CLK} [Hz]	25 MHz	clock frequency of step direction unit	clock frequency of the step direction unit
t_{CLK} [s]	40 ns	clock period length	$t_{CLK} = 1/f_{CLK}$
f_{STEP} [Hz]		$f_{STEP} = (f_{CLK}/2^{32}) * (SD_CHx_STEPRATE)$	step frequency, programmed via step rate accumulation constant $SD_CHx_STEPRATE$
Max. f_{STEP} [Hz]	12.5 MHz		Theoretical maximum value for f_{STEP} . Usable step frequency depends on step pulse length configuration.
t_{STEP} [s]		$t_{STEP} = 1/f_{STEP}$	time between steps
t_{STEP_PULSE} [s]		$t_{STEP_PULSE} = (SD_STEP_LENGTH + 1)/f_{CLK}$	step pulse length must be lower than time between step pulses! $t_{STEP_PULSE} < t_{STEP}$
DIR		DIR = 0 → positive direction, DIR = 1 → negative direction, direction is depending on sign of step rate register $SD_CHx_STEPRATE$ where the step rate register is 2th complement	direction signal, depending of step rate (SR) parameter, DIR = 0 if $SR > 0$ or $SR = 0$, DIR = 1 if $SR < 0$
$t_{STEP1st}$ [s]		time to 1st step pulse since $WR=0$ with $t_{STEP1st} = 2^{32}/SD_CHx_STEPRATE * t_{CLK} + (SD_DELAY + 1) * t_{CLK} + (2 * t_{CLK})$	Time between write until the first step pulse occurs
$t_{STEP1stWR}$ [s]		time to first step pulse since $WR=0$ step delay plus 1 internal clock plus 2 clock cycles to pulse length	Internal processing adds an delay

Table 203: Step and direction unit parameters

Step Rate Accumulation Constant Register `SD_CHx_STEPRATE` The step direction accumulation constant determines the time t_{STEP} between two successive step pulses – this is actually the step rate. Each internal PWM clock accumulates an accumulator according to $a = a + c$ with the accumulator constant c . Toggle of the MSB of the accumulator register a triggers a step pulse. With this principle, the step frequency is smarter adjustable compared to a simple frequency divider. Writing $c = 0$ clears the accumulator and stops the step pulse generation. The step pulse frequency calculates as $f_{STEP} = (f_{CLK}/2^{32}) * c$.

Step Counter Register `SD_CHx_STEPCOUNT` The step counter counts the number of steps, taking the direction into account. This is a read only register. To reset this counter to zero set bit 4 in the `SD_CFG` register.

Step Target Register `SD_CHx_STEPTARGET` The step target defines the number of steps to be made when in target mode. See `SD_CFG` register bit 2. This register can be overwritten at any time. When the number of steps has been made, the unit stops generating S/D pulses. When read, it gives the remaining numbers that must still be made.

Step Compare Register `SD_CHx_COMPARE` This register holds a compare value in numbers of step pulses.

Next Step Rate Register `SD_CHx_NEXTSR` The next step rate register contains a value of the same format as the step rate register. This value is automatically written into the step rate register `SD_CHx_STEPRATE` after a successful compare of the step compare value `SD_CHx_COMPARE` and the actual step counter `SD_CHx_STEPCOUNT`. This way, simple motion profiles can be realized.

Step Length Register `SD_STEPLength` The duration of the step pulse – the step length – signal is programmable for adaption to external power stages.

Note

Maximum step length: The step pulse length t_{STEP_PULSE} must be lower than the time t_{STEP} between step pulses to actually see step pulses at the outputs. The condition $t_{STEP_PULSE} < t_{STEP}$ must be ensured by the application.

Step-to-Direction Delay Register `SD_DELAY` The delay between the first step pulse after a change of the direction is programmable for adaption to external power stages to take external delay paths into account.

Step Direction Unit Configuration Register `SD_CFG` The step direction configuration defines the mode of operation (continuous or defined number of step pulses), polarity of step pulse signal and direction signal. One bit is for zeroing of step pulse counter. One bit is for enabling and disabling of the step pulse unit and compare mode.

Interrupt Output Signal An IRQ signal `TARGET_REACHED` of a single clock pulse length indicates that a certain target position has been reached reached in terms of step counts.

7.15 MFC IO PWM Block

The MFC IO block of TMC8462A offers a 4-channel pulse width modulation (PWM) block including a programmable brake before make (BBM) unit and selection of different PWM modes. Both high side and low side control signals are available as separate outputs. A single PWM counter generates the four synchronous PWM signals. The configurable maximum count defines the PWM frequency. Left aligned PWM, centered PWM, and right aligned PWM is selectable. The BBM timing is individually programmable for high side and low side. Fixed pulses are available for triggering of ADCs or triggering interrupts of a CPU. Additional programmable trigger output signals are available. Signal PULSE_ZERO indicates a start of a new PWM cycle and PULSE_CENTER the center of a PWM cycle. Both are fixed. The two programmable signals PULSE_A and PULSE_B are for advanced ADC triggering. The signal PULSE_AB is the logical or of PULSE_A and PULSE_B. The polarities of the high side, low side, and trigger signals of the PWM unit are programmable.

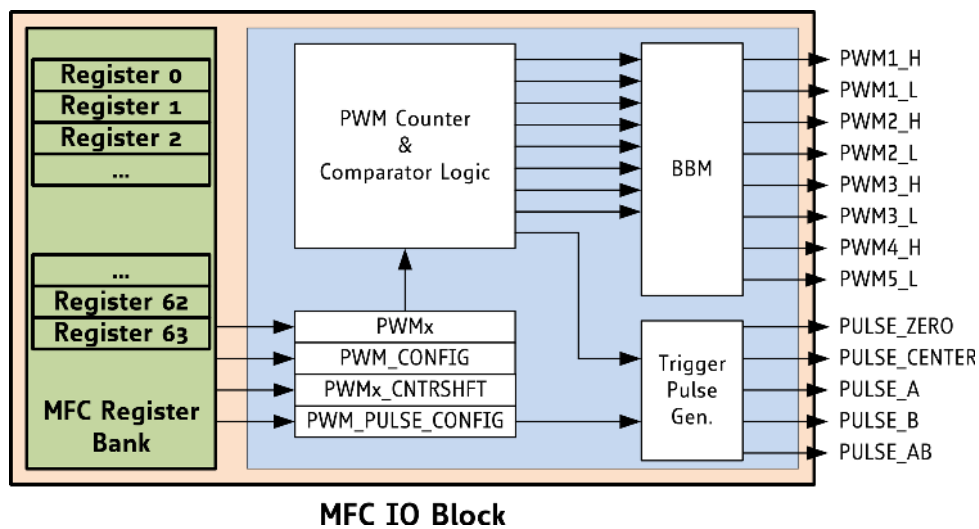

Figure 39: Block structure of the MFC IO PWM Block

Parameter	Value	Description / Function	Comment
f_{CLK} [Hz]	100 MHz	clock frequency of PWM unit	$f_{CLK} = 1/t_{CLK}$
t_{CLK} [s]	10 ns	clock period length	$t_{CLK} = 1/f_{CLK}$
max. t_{PWM} [s]	40.96 us	Length of PWM period $t_{PWM} = t_{CLK} * (1 + PWM_MAXCNT)$	Maximum t_{PWM} with maximum PWM resolution of 12 bit.
min. f_{PWM} [Hz]	24.414 kHz	PWM frequency = $1/t_{PWM}$	Minimal PWM frequency with maximum PWM resolution of 12 bit.
t_{PULSE_LENGTH}		Length of trigger pulses with $t_{PULSE_LENGTH} = PULSE_LENGTH * t_{CLK}$	pulse length is adjustable $t_{CLK} = 10ns$

t_{BBM}		Brake Before Make time t_{BBM} with $t_{BBM_H} = BBM_H * t_{CLK}$ $t_{BBM_L} = BBM_L * t_{CLK}$	Individually programmable for high side and low side due to different timing requirements, especially when using PMOS @ High Side and NMOS @ Low Side
-----------	--	-------------------------------------------------------------------------------------------------------------	-------------------------------------------------------------------------------------------------------------------------------------------------------

Table 204: PWM unit parameters

PWM_MAXCNT Configuration This configuration can be found in the [PWM_CFG register](#). It defines the number of counts per PWM cycle for three PWM units. This determines the length t_{PWM} of each PWM cycle respectively the PWM frequency f_{PWM} . It is programmable for adjustment of the PWM frequency f_{PWM} .

PWM_CHOPMODE Configuration This configuration can be found in the [PWM_CFG register](#). It selects the chopper mode of the 4 PWM channels. Each channel can be configured individually. The following table gives the available chopper modes.

Selection	Chopper	High Side	Low Side	Function
000	no	off	off	no chopper, all off
001	no	off	on	no chopper, LS permanent on
010	no	no	off	no chopper, HS permanent on
011	no	off	off	no chopper, all off, not used
100	no	off	off	no chopper, all off, not used
101	yes	off	PWM	chopper LS, HS off
110	yes	PWM	Off	chopper HS, LS off
111	Yes	PWM	not PWM	chopper HS and LS complementary, brake-before-make is handled by programmable BBM unit

Table 205: PWM modes

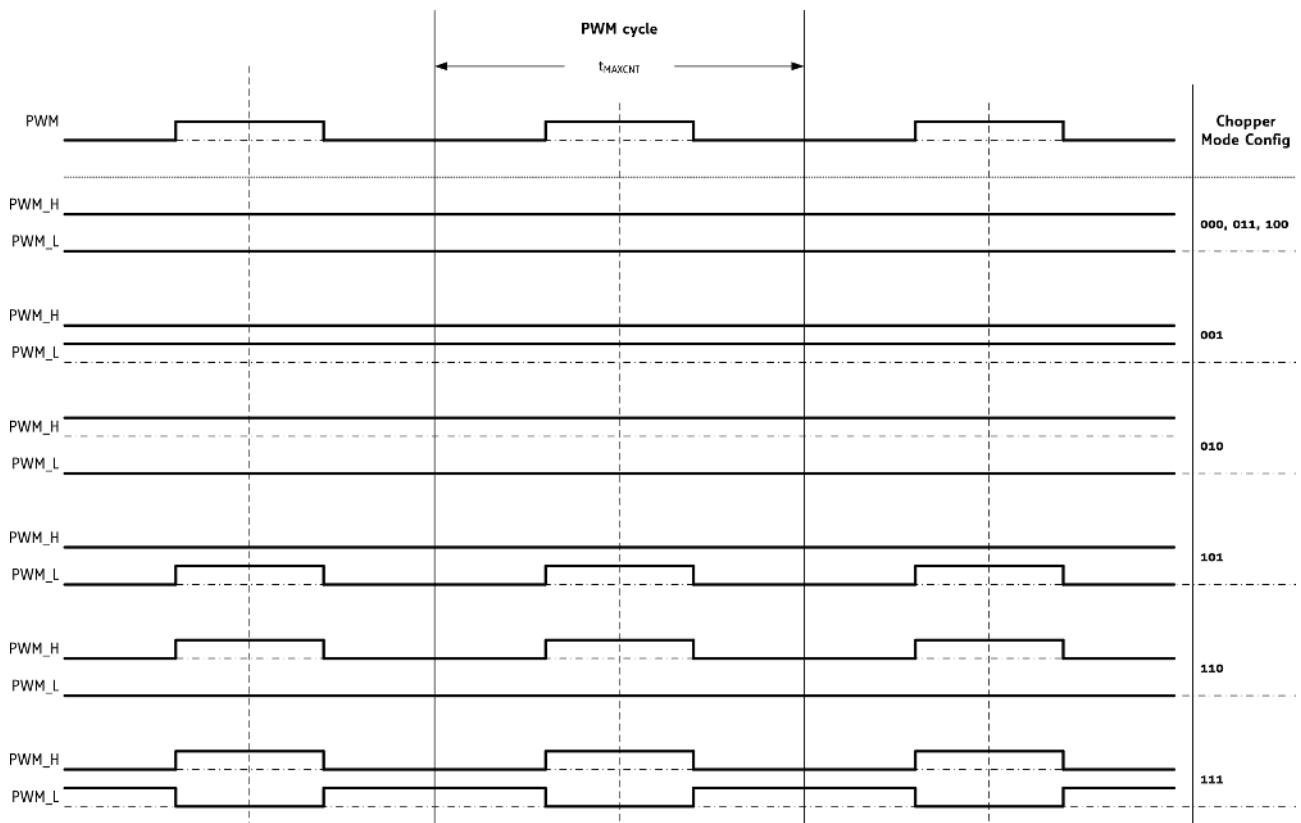

Figure 40: PWM chopper modes

PWM Alignment Configuration This configuration can be found in the [PWM_CFG register](#). It determines the alignment of the 4 PWM units. The alignment can be programmed left aligned, centered, or right aligned. All 4 channels use the same configuration.

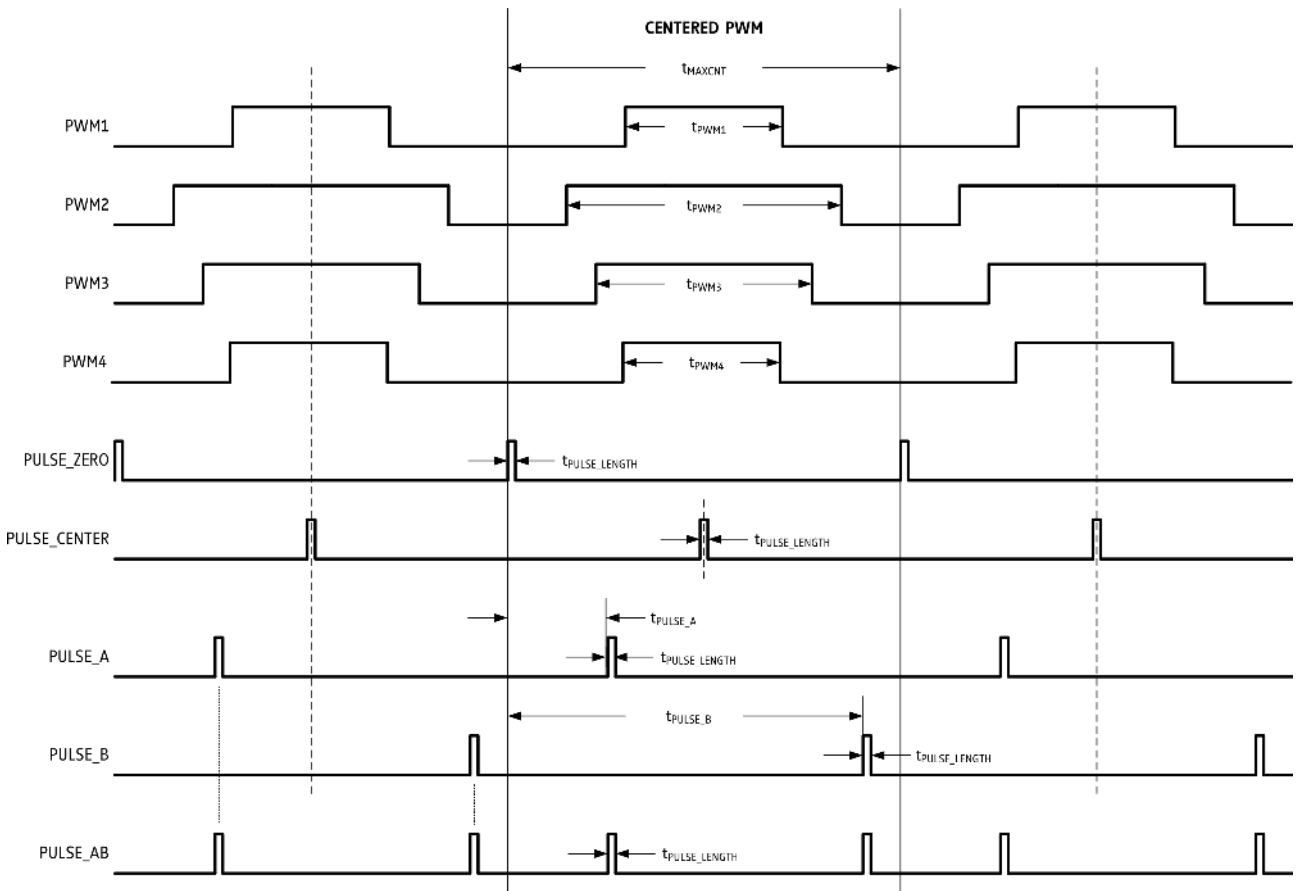

Figure 41: PWM Timing (centered PWM)

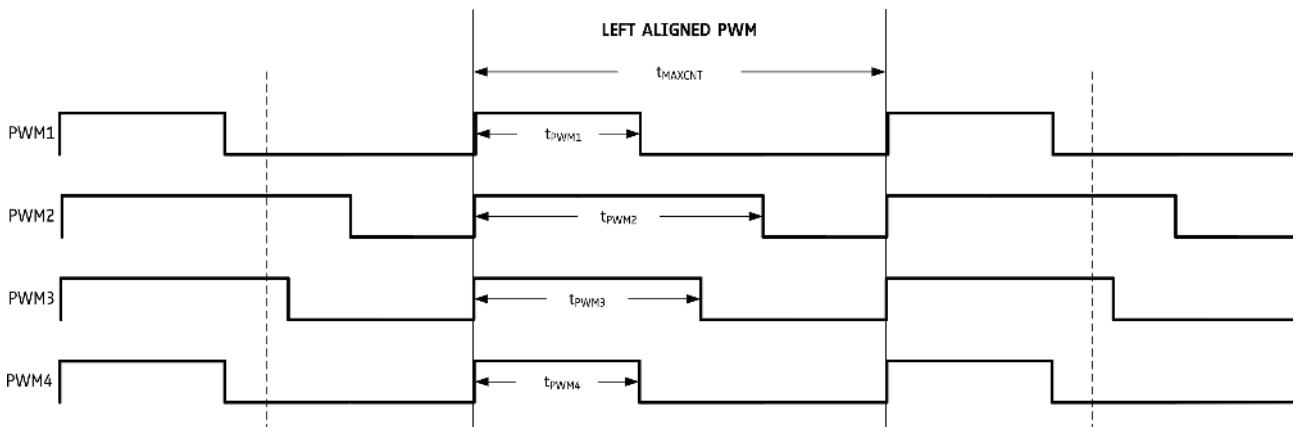

Figure 42: PWM Timing (left aligned PWM)

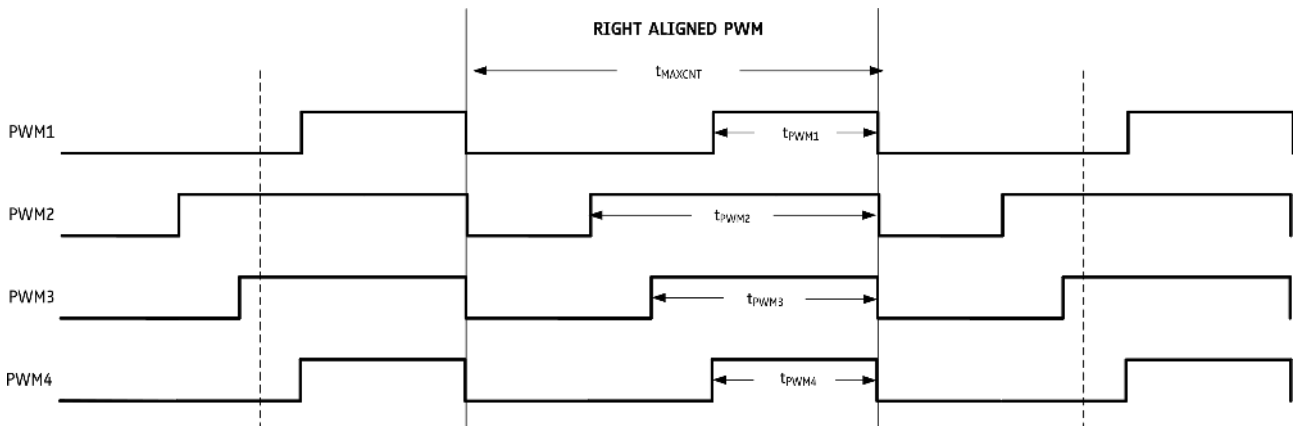

Figure 43: PWM Timing (right aligned PWM)

PWM Polarity Configuration This configuration can be found in the [PWM_CFG register](#). The PWM signals of the 4 channels are of positive logic. Logical one level means ON and logical zero level means OFF. Depending on the MOSFET drivers, switching on a MOSFET might require an inverted logical level. The polarity configuration determines the switching polarities for the high side MOSFETs and switching polarities for the low side MOSFETs.

BBM Configuration This configuration can be found in the [PWM_CFG register](#). To avoid cross conduction of the half bridges the brake before make (BBM) timing is programmable. In most cases the same BBM time is sufficient for both low side and high side. The BBM time should be programmed as short as possible and as long as necessary. A too long BBM time causes conduction of the bulk diodes of the power MOSFETs and that causes higher power dissipation. In case of using PMOSFETs for high and NMOSFETs for low side with asymmetric switching characteristics, it might be advantageous to program different BBM_H and BBM_L times.

The BBM_L is the time from switch off the high side to switch on the low side in terms of clock cycles. The BBM_L is common for all 4 high side power MOSFETs. The BBM_H is the time from switch off the low side to switch on the high side in terms of clock cycles. The BBM_H is common for all 4 low side power MOSFETs.

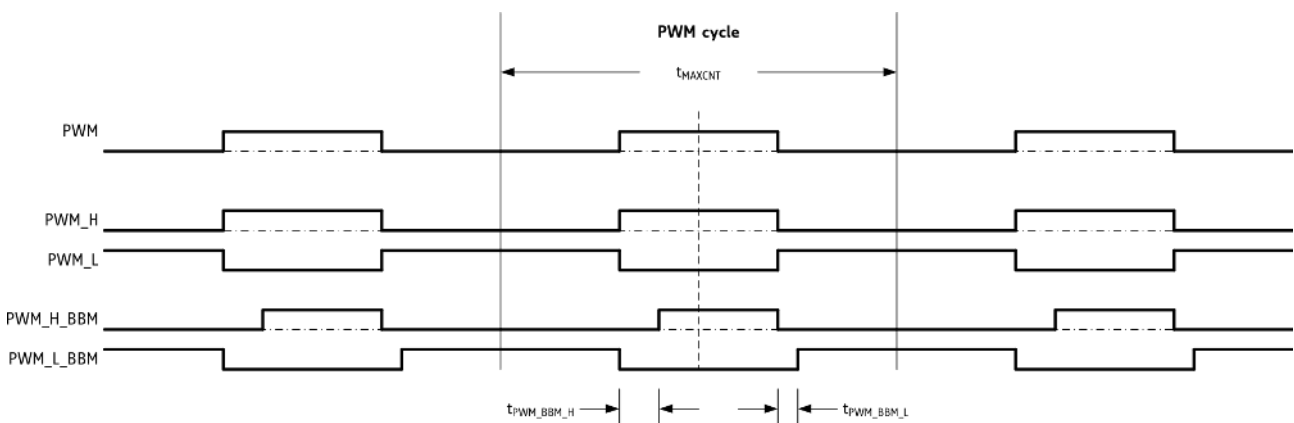

Figure 44: PWM BBM Timing

PWM Value Together with the programmed PWM counter length, the PWM values determine the PWM duty cycle. The PWM duty cycle is individually programmable for each of the 4 PWM channels.

Trigger Pulses A and B Configuration The positions of the trigger pulses A and B are programmable within the PWM cycle. These pulses can be used for different purpose, e.g., to trigger ADC sampling at a specific point in time.

Trigger Pulse Length Configuration The length of PULSE_A and PULSE_B and the fixed trigger pulses PULSE_CENTER and PULSE_ZERO is programmable in terms of clock cycles.

Asymmetric PWM Configuration To realize a wider time window between PWM switching events that are close to each other, an asymmetric PWM shift can be programmed individually for each PWM channel. This leaves the PWM duty cycles unchanged. It is useful for current measurement with sense resistors at the bottom of the MOSFET half bridges.

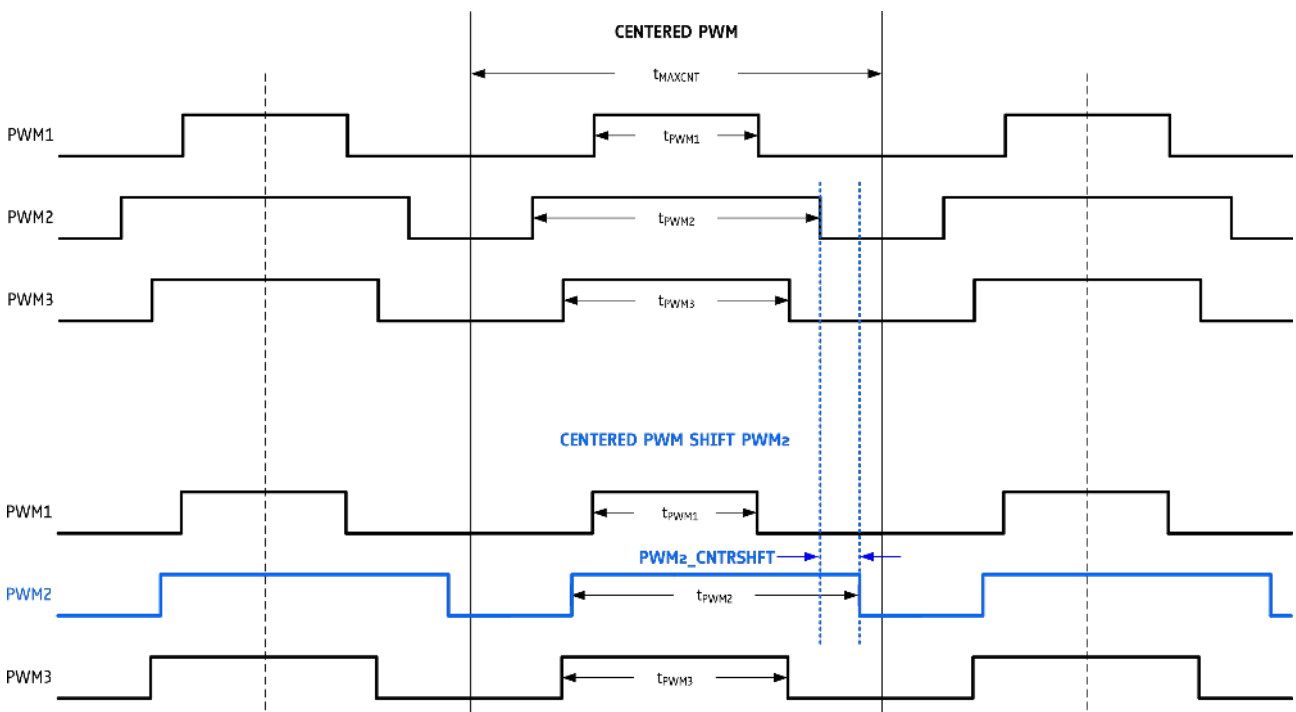

Figure 45: Centered PWM with PWM channel 2 shifted from center (example showing only 3 PWM channels)

7.16 MFC IO DAC Block

The DAC block generates a digital signal based on a 16 bit pseudo random number generator (PRNG). A pseudo random number (PRN) is compared to the desired output value and a the output is set to 1 if the PRN is lower than the output value. The PRN generator is clocked with 100MHz, which results in a period length of $655.36\mu\text{s}$. The output signal can be filtered with a simple RC lowpass.

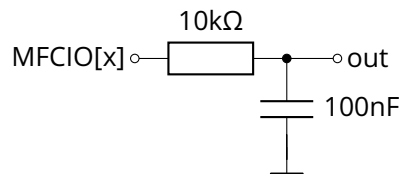

Figure 46: RC filter for DAC output with example values

Note

The high voltage outputs are not able to output this signal properly as their slew rate does not allow 10ns pulses. This will lead to voltage levels that don't correspond with the set value. It is recommended to use the DAC block only with the low voltage outputs.

7.17 MFC IO General Purpose IO Block

TMC8462A has 16 general purpose IO lines that can be freely configured and used via the 24 MFC IO low voltage and high voltage pins. The general purpose IO signals can be used for indicator LEDs, switch inputs, and even for relays or small DC motors on the HVIO pins.

When configured as an output signal, a safe state for each signal is available that is set on the pin in case the emergency state is triggered using MFC_NES.

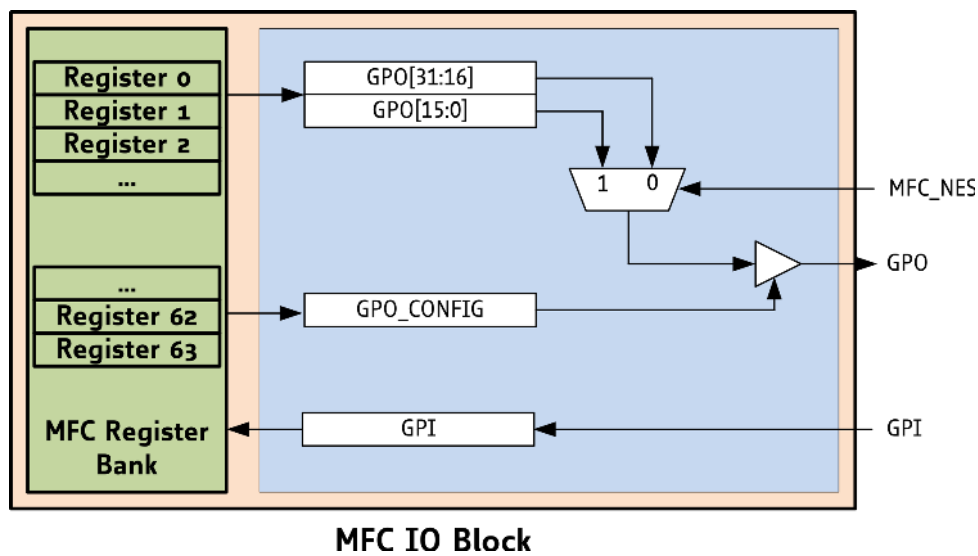

Figure 47: Block structure of GPIO Unit

After reset, all signals are configured as an input and present a Hi-Z state on the GPIO pin they are mapped to. When a signal should be used as an input signal, no further configuration is required after reset, the signal state can be read directly from the GPI register (7.3.6.2).

To configure a signal as an output, a 1 bit must be written to the signal position in the GPIO_CONFIG register (7.3.6.3). Afterwards, the signal can be controlled via the lower 16 bits of the GPO register (7.3.6.1). The upper 16 bits of the GPO register represent the state in case the emergency state is triggered.

GPO (31..16)	GPO (15..0)	GPIO_CONFIG	MFC_NES	GPO signal	Comment
X	X	0	X	Hi-Z	Reset state
X	0	1	1	0	Normal operation
X	1	1	1	1	Normal operation
0	X	1	0	0	Emergency State safe output
1	X	1	0	1	Emergency State safe output

Table 206: GPO signal output states

7.18 MFC IO IRQ Block

The MFC_IRQ output signal is driven by the MFC IO IRQ block and can be used to indicate various events of the MFC IO block. The IRQ unit uses **two registers** to configure certain IRQ trigger events and to check the IRQ source when the MFC_IRQ has been triggered.

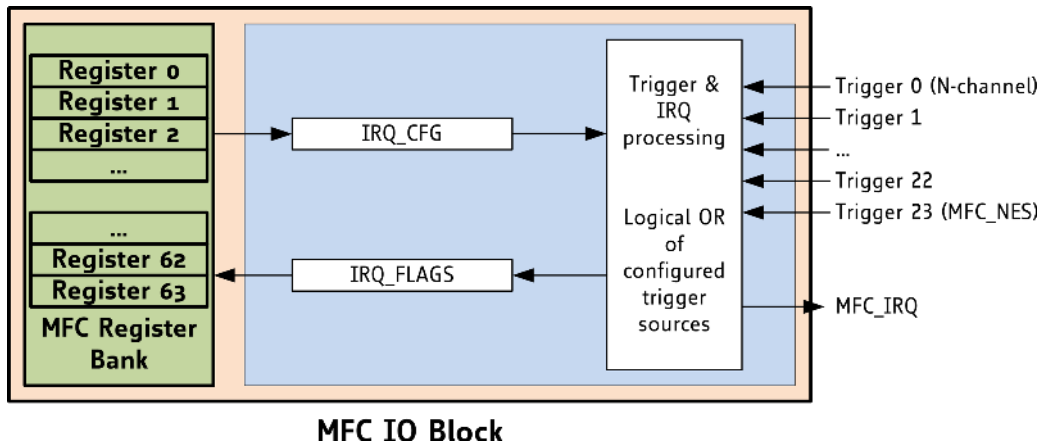

Figure 48: Block structure of the MFC IO IRQ Block

IRQ MASK Register The IRQ mask register allows to enable/disable certain IRQ trigger events of the MFCIO block.

IRQ FLAGS Register This register can be read out after the IRQ was set to identify the IRQ source (especially when more than one IRQ source was masked). Reading out clears this register.

7.19 MFC IO Watchdog Block

General Function The watchdog timer allows monitoring of external signals, or monitoring of EtherCAT activity. A certain condition can be chosen for retriggering the watchdog, i.e. a certain input signal constellation. In case this constellation does not occur at least once within a pre-programmable time period, the watchdog timer will expire and will trigger a certain watchdog action.

To avoid static reset of the watchdog, the watchdog input condition is edge sensitive, i.e. it becomes reset when the condition goes active respectively goes inactive. Once the watchdog expires, the watchdog safety circuitry becomes active. This action can bring I/O lines into a certain state, in order to allow the system to return to a known, safe condition. Therefore, all I/O lines are directly mapped to the GPIO ports of the chip, so that they perform independently of the actually configured peripheral configuration.

The watchdog action can be chosen to remain active continuously, until it becomes reset by a watchdog re-configuration, or it can be programmed to return to normal operation state, once the selected condition becomes true again.

In an optional use case, the watchdog timer can be used to measure the maximum delay in between of the occurrence of certain input conditions, in between of SPI frames, etc.

The watchdog unit finds itself between the MFC IO crossbar and the IO pads as shown in Figure 49. Thus, the watchdog monitors the 24 MFCIOxx signals. Depending on the crossbar mapping these signals are either inputs or outputs. Their logical function depends on the crossbar mapping to/from the MFC IO functional sub-blocks.

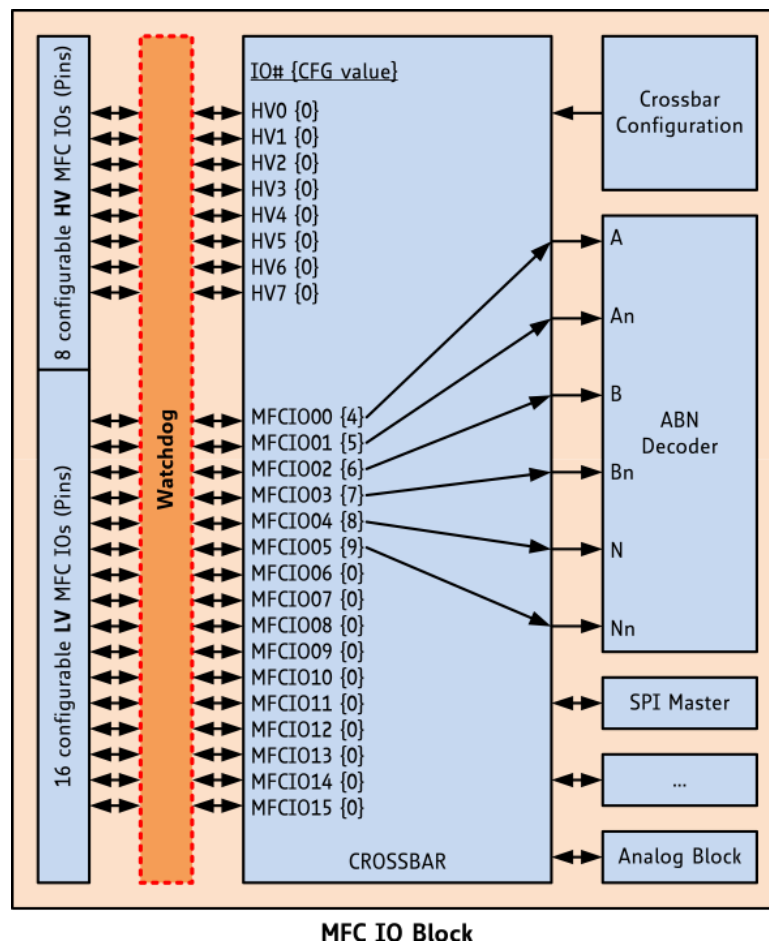

Figure 49: Logical position of the MFC IO watchdog unit between crossbar and MFCIOxx pins

Watchdog Register Set Once initialized, the watchdog timer monitors the application for activity and allows setting of pre-programmed I/O patterns, in case the time limit is expired without activity.

In order to allow tuning of this time limit, the maximum time between two trigger events becomes measured. This function also allows delay time measurement for input channels (i.e. when no watchdog action is chosen). The watchdog timeout counter starts from zero up to WD_TIME. When it reaches WD_TIME, it triggers the watchdog action.

The selected watchdog event resets the timeout counter. As trigger sources, the internal EtherCAT start of frame (PDI_SOF), the two SPI chip select signals (PDI_SPI_CSN and MFC_CTRL_SPI_CSN) as well as any combination of I/O lines can be used. For the I/O lines (MFCIO00 to MFCIO23), the polarity and edge are programmable.

When using an MFCIOxx pin programmed as output and as watchdog trigger, the watchdog circuitry will monitor the real output by checking the polarity of the output signal. This way, also a short circuit condition will be detected. The chip select signals respond to a rising edge (i.e. when the SPI interface loads the SPI shift register data into the corresponding registers).

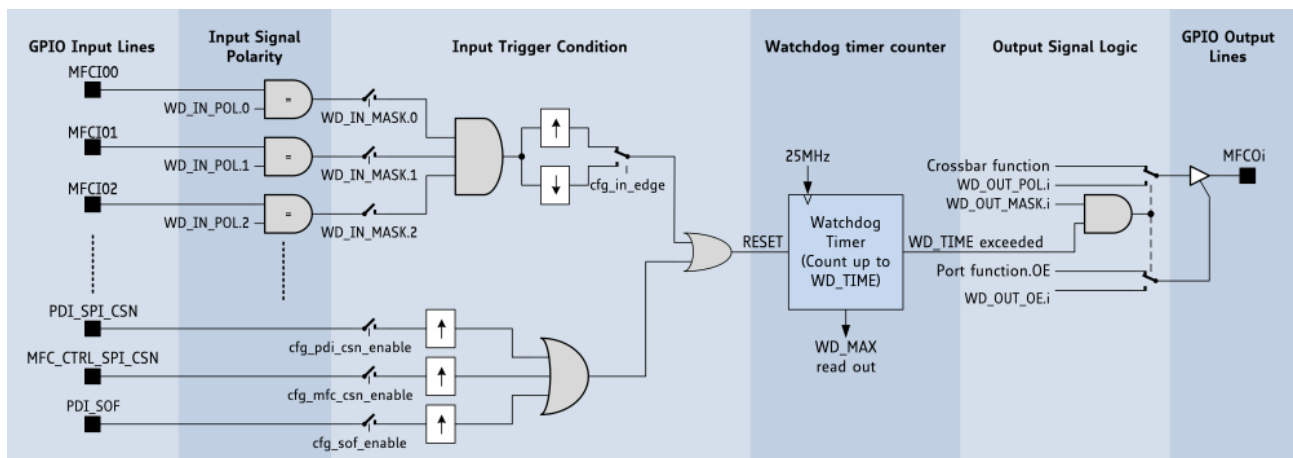

Figure 50: Structure of the MFC IO watchdog unit

Watchdog Output Port Configuration The following table contains the assignments of ports/signals to the configuration bits in the `WD_OUT_MASK_POL` register. An MFCIOxx pin programmed as output is called MFCIOxx.

Bit #	Signal	Bit #	Signal
0	MFCIO00 polarity	32	MFCIO00 mask
1	MFCIO01 polarity	33	MFCIO01 mask
2	MFCIO02 polarity	34	MFCIO02 mask
3	MFCIO03 polarity	35	MFCIO03 mask
4	MFCIO04 polarity	36	MFCIO04 mask
5	MFCIO05 polarity	37	MFCIO05 mask
6	MFCIO06 polarity	38	MFCIO06 mask
7	MFCIO07 polarity	39	MFCIO07 mask
8	MFCIO08 polarity	40	MFCIO08 mask

Bit #	Signal	Bit #	Signal
9	MFCO09 polarity	41	MFCO09 mask
10	MFCO10 polarity	42	MFCO10 mask
11	MFCO11 polarity	43	MFCO11 mask
12	MFCO12 polarity	44	MFCO12 mask
13	MFCO13 polarity	45	MFCO13 mask
14	MFCO14 polarity	46	MFCO14 mask
15	MFCO15 polarity	47	MFCO15 mask
16	MFCO16 polarity	48	MFCO16 mask
17	MFCO17 polarity	49	MFCO17 mask
18	MFCO18 polarity	50	MFCO18 mask
19	MFCO19 polarity	51	MFCO19 mask
20	MFCO20 polarity	52	MFCO20 mask
21	MFCO21 polarity	53	MFCO21 mask
22	MFCO22 polarity	54	MFCO22 mask
23	MFCO23 polarity	55	MFCO23 mask
24	unused/reserved	56	unused/reserved
25	unused/reserved	57	unused/reserved
26	unused/reserved	58	unused/reserved
27	unused/reserved	59	unused/reserved
28	unused/reserved	60	unused/reserved
29	unused/reserved	61	unused/reserved
30	unused/reserved	62	unused/reserved
31	unused/reserved	63	unused/reserved

Table 207: MFC IO watchdog WD_OUT_MASK_POL signal/port assignment

Watchdog Input Port Configuration The following table contains the assignments of ports/signals to the configuration bits in the **WD_IN_MASK_POL** register. An MFCIOxx pin programmed as input is called MFCIxx.

Bit #	Signal	Bit #	Signal
0	MFCI00 polarity	32	MFCI00 mask
1	MFCI01 polarity	33	MFCI01 mask
2	MFCI02 polarity	34	MFCI02 mask
3	MFCI03 polarity	35	MFCI03 mask
4	MFCI04 polarity	36	MFCI04 mask

Bit #	Signal	Bit #	Signal
5	MFCI05 polarity	37	MFCI05 mask
6	MFCI06 polarity	38	MFCI06 mask
7	MFCI07 polarity	39	MFCI07 mask
8	MFCI08 polarity	40	MFCI08 mask
9	MFCI09 polarity	41	MFCI09 mask
10	MFCI10 polarity	42	MFCI10 mask
11	MFCI11 polarity	43	MFCI11 mask
12	MFCI12 polarity	44	MFCI12 mask
13	MFCI13 polarity	45	MFCI13 mask
14	MFCI14 polarity	46	MFCI14 mask
15	MFCI15 polarity	47	MFCI15 mask
16	MFCI16 polarity	48	MFCI16 mask
17	MFCI17 polarity	49	MFCI17 mask
18	MFCI18 polarity	50	MFCI18 mask
19	MFCI19 polarity	51	MFCI19 mask
20	MFCI20 polarity	52	MFCI20 mask
21	MFCI21 polarity	53	MFCI21 mask
22	MFCI22 polarity	54	MFCI22 mask
23	MFCI23 polarity	55	MFCI23 mask
24	unused/reserved	56	unused/reserved
25	unused/reserved	57	unused/reserved
26	unused/reserved	58	unused/reserved
27	unused/reserved	59	unused/reserved
28	unused/reserved	60	unused/reserved
29	unused/reserved	61	unused/reserved
30	unused/reserved	62	unused/reserved
31	unused/reserved	63	unused/reserved

Table 208: MFC IO watchdog WD_IN_MASK_POL signal/port assignment

7.20 MFC IO Emergency Switch Input

The MFC IO block offers a dedicated emergency switch input called MFC_NES. It is low active. It is used to set specific MFCIOxx outputs to a configurable safe state in case of emergency. The MFC_NES pin has weak internal pull-down resistor. A microcontroller or another circuit must actively drive a high level at MFC_NES for normal operation. The emergency switch input MFC_NES is only active if it is masked in the [MFCIO_IRQ_CFG](#) register at bit 23. Otherwise it is ignored. If MFC_NES triggers (low level), the respective outputs take their configured safe values. The internal emergency switch flag remains set in register [MFCIO_IRQ_FLAGS](#) even when the external pin MFC_NES is already driven high again.

MFC_NES has impact on the following functional units and outputs:

- [MFC IO PWM block](#): the PWM high and low side gate outputs are set to a defined configurable safe off-state.
- [MFC IO GPIO block](#): all GPIOs that are configured as output ports via the crossbar are set to a defined configurable safe off-state.
- [MFC IO Step and Direction block](#): the step outputs and internal step counters freeze.
- The MFCIO_IRQ signal will be triggered.

Note

The emergency flag can only be unset by either doing a reset or by actively writing 2 times into the [MFCIO_IRQ_CFG](#) register at bit position 23. Thereby, the existing IRQ mask at bit 23 must first be set to zero and then set back to 1 again. This way, the internal emergency flag is unset. This can be done either by the local application controller or by the EtherCAT master if it has access to register [MFCIO_IRQ_CFG](#).

7.21 MFC IO Analog and High Voltage Block

7.21.1 Multi Voltage High Current I/O Lines

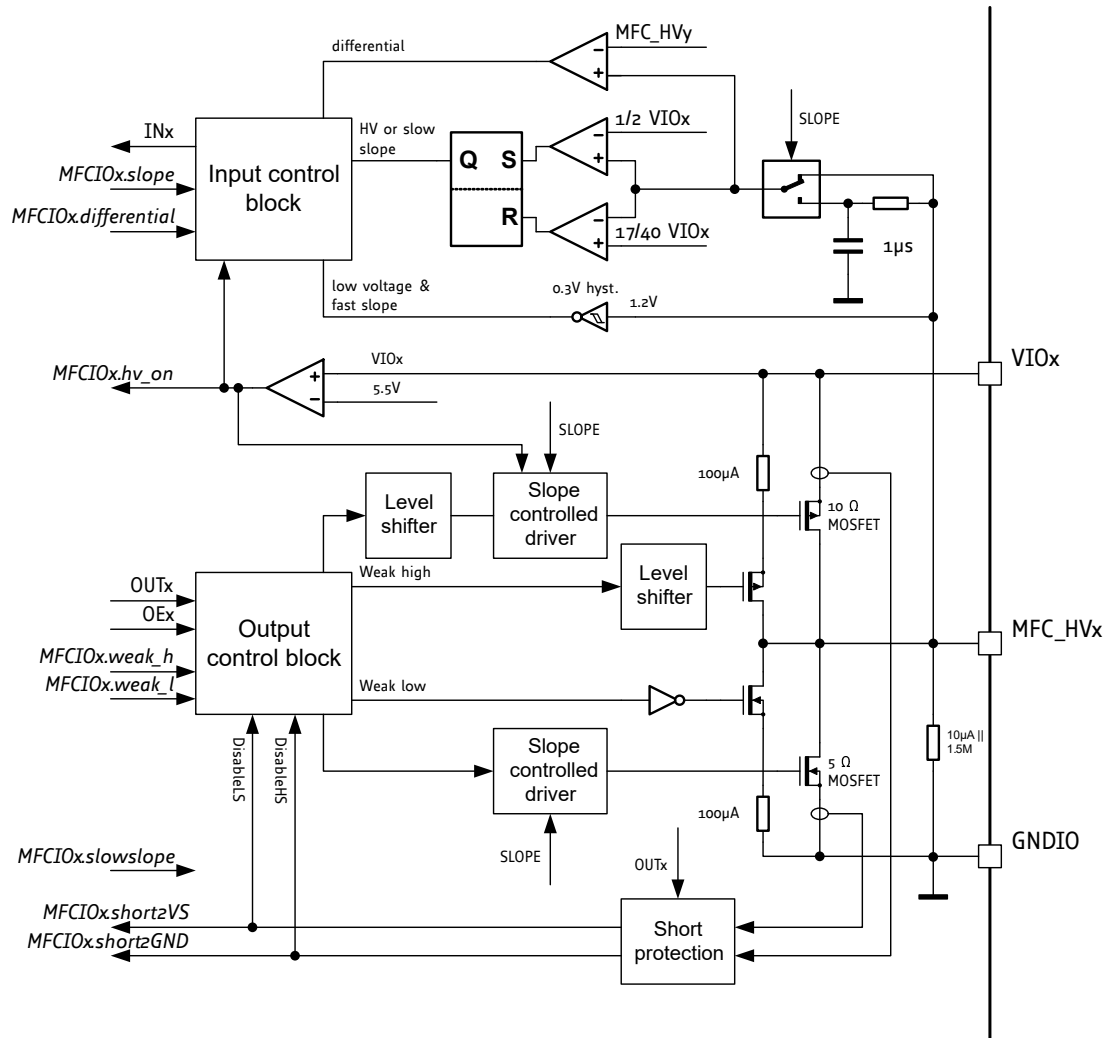

Figure 51: Schematic of multi voltage I/O port

Output Characteristics The multi voltage I/O lines allow direct driving of loads like lamps, LEDs or solenoids with up to 100mA output current (200mA short time peak). They can be operated in a push / pull mode, or in low current mode by using an internal pullup / pulldown resistor / current source combination. The eight multi-voltage I/Os are grouped into three groups, which allow the use at the same, or different supply voltages.

In case inductive loads are driven, or loads with long interconnection cables, Schottky protection diodes shall be added in order to avoid exceeding the respective supply voltage limits.

A slope limited mode allows reducing electromagnetic emission by using slower switching slopes. Additional filter capacitors (up to 1nF recommended) may be placed on the output lines in this mode to eliminate any HF noise.

The outputs provide a short to GND and short to supply protection. When an overcurrent condition is detected, the respective MOSFET remains switched off for the period of constant polarity. The short circuit detection features a current dependent activation time. The lower activation threshold is about

150mA. Upon exceeding the activation threshold, a time proportional to the excess current is required to switch off the output. This way, short time peak currents can safely be switched, e.g. when long cables or capacitive loads are attached.

An interrupt flag informs about an active overcurrent condition. The short condition will be cleared once the output polarity is toggled.

Input Characteristics The inputs automatically adapt to the supply voltage range. In low voltage range (up to 5V operation), a fast digital Schmitt trigger is used for evaluation of the input logic levels. It provides a TTL compatible input level.

In the high voltage range, the input path switches to a threshold voltage just at half supply voltage range. Both modes add a hysteresis in order to avoid oscillation with slow transitions on the inputs. When switching to slow slope operation, the input lines become filtered in order to eliminate reaction to short voltage spikes. In this mode, the half level comparator is always used. A minimum pull down current of $10\mu A$ is always drawn in order to ensure a defined level on an open input.

The inputs allow a differential mode between each two combined inputs (see combination table). It is important to set both inputs to the same slope setting in this case. Both input lines deliver a comparison result using each one voltage comparator. This allows direct attachment of differential voltage sources like encoders. The addition of input protection resistor networks is recommended in case long cables are used.

⚠ WARNING

When driving inductive loads a freewheeling diode must be provided to the high voltage I/O pins to prevent from latch-up.

Differential input pair	Input 1	Input 2
A	MFC_HV0	MFC_HV3
B	MFC_HV1	MFC_HV4
C	MFC_HV2	MFC_HV5
D	MFC_HV6	MFC_HV7

Table 209: Differential input combination table

The inputs are read via Input 1 result.

7.21.2 Switching Regulators

The TMC8462A integrates a programmable and a fixed buck switching regulator designed for up to 500mA of output current.

The fixed regulator has a fixed output voltage of 3.3V. Its main purpose is to supply the TMC8462A I/Os and the digital part via the 1.8V linear regulators. This regulator comes with an integrated 800mA 5.5V Schottky diode which minimizes part count, when an external 5V supply is available. In case of a higher supply voltage, use an external Schottky diode instead.

The second regulator can be programmed to any output voltage ranging from 1.2V up to the supply voltage level. It can be used to generate an additional 3.3V supply or any additional voltage like 5V, 12V or 24V required for operation of peripheral circuits or the high voltage I/O lines. An integrated common linear 5V regulator starts up the switch regulators. Cascading of both switch regulators also is possible.

Both regulators support a wide range of L and C components. This is enabled by a programmable current feedback loop gain and compensation capacity. Both switching regulators provide optional dampening of the coil oscillations to reduce electromagnetic emission.

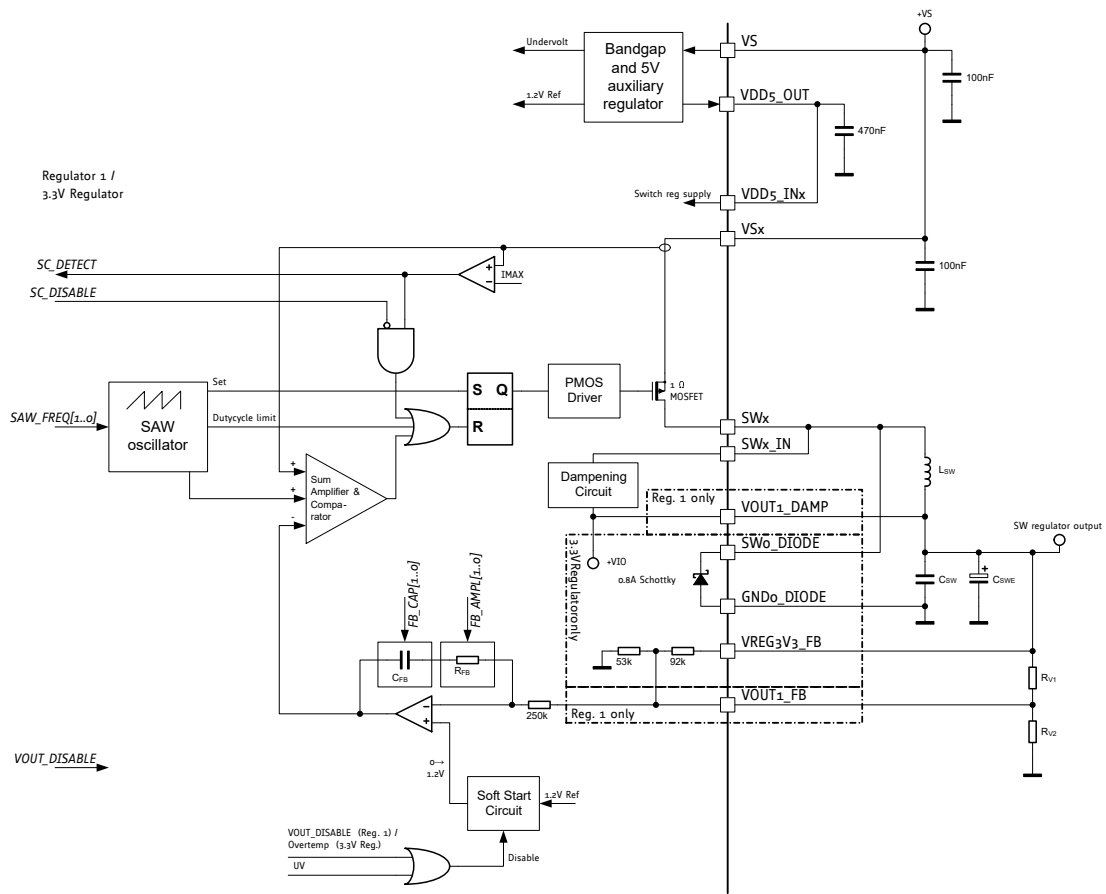

Figure 52: Internal schematic and external components for both switching regulators

Input voltage	Output voltage	L_{SW}	C_{SW}
5V	3.3V	15 μ H	22 μ F
24V	3.3V to 12V	68 μ H	47 μ F
35V	3.3V to 25V	68 μ H	47 μ F

Table 210: Switching regulator component selection for L and C

Info

The capacitor can either be a ceramic type, or an electrolytic low-ESR capacitor in parallel to a 1 μ F or larger ceramic capacitor.

7.21.3 Analog Block Status Register

MFC IO Register 59 HV_ANA_STATUS provides various status flags on the actual state of the analog block. This includes:

- short to ground and short to supply detection for the HV IOs
- high voltage detection flags for the HV IOs

- over-temperature detection for the HV IO circuit
- short circuit/over-current detection for the switching regulators
- over-temperature detection for the adjustable switching regulator

Please refer to Table [184](#) for more details.

8 Electrical Ratings

8.1 Absolute Maximum Ratings

Note The maximum ratings may not be exceeded under any circumstances. Operating the circuit at or near more than one maximum rating at a time for extended periods shall be avoided by application design.

Parameter	Symbol	Min	Max	Unit
Supply and HV IO supply voltage with $T_J = 0^\circ\text{C}$ *)	V_{VS}, V_{VIOx}		40	V
Supply and HV IO supply voltage max. with T_J full range *)	V_{VS}, V_{VIOx}		35	V
Maximum voltage on HV IO pins	V_{VIO}	-0.6	$V_{VIOx}+0.6$	V
Peak current into HV IO input protection diodes (100ms)	$I_{HVIOPEAK}$	-100	+100	mA
Digital I/O supply voltage	V_{VIO}		3.6	V
Digital VCC supply voltage (if not supplied by internal regulator)	V_{VCC}		1.98	V
Logic input voltage	V_I		3.6	V
Maximum current to / from digital pins and analog low voltage I/Os	I_{IO}		10	mA
1.8V regulator output current (internal plus external load)	I_{VOUT18}			mA
Switching regulator repetitive short time output current	I_{VOUTSW}		800	mA
Schottky diode reverse voltage	V_{SDR}		7	V
Schottky diode repetitive short time forward current	I_{SD}		800	mA
Junction temperature	T_J	0	+125	$^\circ\text{C}$
Storage temperature	T_{STG}	-55	+150	$^\circ\text{C}$
ESD-Protection for interface pins (Charge Device Model, CDM)	V_{ESDAP}		750	V
ESD-Protection for handling (Human body model, HBM)	V_{ESD}		2.5	kV

Table 211: Absolute Maximum Ratings for TMC8462A-BA

*) Stray inductance of GND and VS connections will lead to ringing of the supply voltage when driving load. This ringing results from the fast switching slopes of the driver outputs in combination with reverse recovery of the body diodes of the output driver MOSFETs. Even small trace inductance as can easily generate a few volts of ringing leading to temporary voltage overshoot. This should be considered when working near the maximum voltage.

8.2 Operational Ratings

Parameter	Symbol	Min	Max	Unit
Junction temperature	T_J	0	+85	°C
High voltage supply voltage	$V_{VS,VS0,VS1}$	4.75	34	V
Digital I/O 3.3V supply voltage	V_{VCCIO}	3.15	3.45	V
I/O supply voltage (high voltage I/Os)	V_{VIOx}	6.0	34	V
I/O Supply voltage (low voltage I/Os)	V_{VIOx}	3.0	5.5	V
Continuous output current single high voltage I/O	$I_{OUT,HVIO}$		100	mA
Continuous current into / from any high voltage I/O supply or GND pin	$I_{IN,HVIO}$		200	mA
Switching regulator DC output current	$I_{OUT,SW}$		500	mA
3.3V Switching regulator supply voltage when using internal Schottky diode		4	5.5	V
Core supply voltage	V_{VCC_CORE}	1.65	1.95	V

Table 212: Operational Ratings for TMC8462A-BA

8.3 DC Characteristics and Timing Characteristics

DC characteristics contain the spread of values guaranteed within the specified supply voltage range unless otherwise specified. Typical values represent the average value of all parts measured at +25 °C. Temperature variation also causes stray to some values. A device with typical values will not leave Min/Max range within the full temperature range.

8.3.1 High Voltage I/O Block

⚠ WARNING

When driving inductive loads a freewheeling diode must be provided to the high voltage I/O pins to prevent from latch-up.

Parameter	Symbol	Conditions	Min	Typ	Max	Unit
HV supply current per high voltage I/O pad	I_{HVIO}	No current driven, static mode		90	140	μA
R_{DSon} low side	R_{ONL}	$T_J=25\text{ °C}$		6	10	Ω
R_{DSon} high side	R_{ONH}	$V_{VIOx}=5\text{ V}; T_J=25\text{ °C}$		10	15	Ω
R_{DSon} high side	R_{ONH}	$V_{VIOx}=3.3\text{ V}; T_J=25\text{ °C}$		13	20	Ω
Weak pull down current	I_{PD}		37	63	115	μA
Weak pull up current	I_{PU}	$V_{VIOx}=5\text{ V}; T_J=25\text{ °C}$	66	110	210	μA
Weak pull up current	I_{PU}	$V_{VIOx}=3.3\text{ V}; T_J=25\text{ °C}$	50	76	150	μA

Parameter	Symbol	Conditions	Min	Typ	Max	Unit
Over-current protection activation threshold sourcing	I_{OCH}	Output sourcing current	-100	-150	-500	mA
Over-current protection activation threshold sinking	I_{OCL}	Output sinking current	100	150	500	mA
200mA sink current capability time limit	t_{OCL200}	Output sinking current	10			μs
Switching slope (slow) rising	t_{HVOLH}	10% to 90%	100	200	500	ns
Switching slope (slow) falling	t_{HVOHL}	90% to 10%	100	200	500	ns
Switching slope (fast) rising	t_{HVOLH}	10% to 90%		20		ns
Switching slope (fast) falling	t_{HVOHL}	90% to 10%		20		ns
Input filter time constant	t_{HVIF}	Slow slope setting	750	1000	1500	ns
Input threshold (LV mode)	V_{HVILLL}	Input going low, $V_{VIOx}=5.5 V$	0.8			V
Input threshold (LV mode)	V_{HVIHLL}	Input going high, $V_{VIOx}=5.5 V$			1.6	V
Input hysteresis (LV mode)	$V_{HVIHYSTL}$	$V_{VIOx}=5.5 V$	0.1	0.3		V
Input threshold (HV mode)	V_{HVIHLH}	Input going high		$0.5 V_{VIO}$		V
Input threshold (HV mode)	V_{HVILLH}	Input going low		$0.43 V_{VIO}$		V
Input hysteresis (HV mode)	$V_{HVIHYSTH}$			$0.075 V_{VIO}$		V
Differential mode input offset voltage (LV mode and fast slope)	V_{HVID}	Common mode voltage $\geq 0.5 V$	-10	0	+10	mV
Differential mode input offset voltage (HV mode or slow slope setting)	V_{HVID}	Common mode voltage $\geq 2 V$	-150	0	+150	mV
Input delay (300mV step)		Differential mode, fast slope			100	ns
Input current per high voltage I/O pad (HV mode)	I_{HVIOH}	$V_{HVIO} = V_{VIOx} = 24 V$		26	50	μA
Input current per high voltage I/O pad (LV mode)	I_{HVIOH}	$V_{HVIO} = V_{VIOx} = 3.0 V$ to $5 V$		10	15	μA

Table 213: High Voltage I/O Block DC Characteristics

8.3.2 Switching Regulators

Parameter	Symbol	Conditions	Min	Typ	Max	Unit
HV supply current per high voltage I/O pad	I_{VHVIO}	No current driven, static mode		90	140	μA

Parameter	Symbol	Conditions	Min	Typ	Max	Unit
R_{Dson} power switch	R_{ON}	$T_J=25\text{ °C}$		1	1.5	Ω
Over-current protection activation threshold sourcing	I_{OCH}	Output sourcing current	800	1200	1600	mA
Oscillator frequency	f_{OSC}	Setting 00 (default) Setting 01 Setting 10 Setting 11		240 130 470 890		kHz
Duty cycle limit	dl			83		%
Schottky diode forward voltage	V_{SDF}	$I=350\text{mA}$		0.60	0.80	V
Soft startup time				1		ms
5V auxiliary voltage regulator output voltage	V_{VDD5_OUT}		4.75	5	5.25	V
5V auxiliary voltage regulator output current limit	I_{VDD5_OUT}			10		mV

Table 214: Switching Regulator DC Characteristics

8.3.3 Digital I/Os

All I/O lines include Schmitt-Trigger inputs to enhance noise margin.

Parameter	Symbol	Conditions	Min	Typ	Max	Unit
Input voltage low level	V_{INL}	$V_{VCCIO} = 3.3\text{V}$	-0.3		0.8	V
Input voltage high level	V_{INH}	$V_{VCCIO} = 3.3\text{V}$	2.3		3.6	V
Input with pull-down		$V_{IN} = 3.3\text{V}$	5	30	110	μA
Input with pull-up		$V_{IN} = 0\text{V}$	-110	-30	-5	μA
Input low current		$V_{IN} = 0\text{V}$	-10		10	μA
Input high current		$V_{IN} = V_{DD}$	-10		10	μA
Output voltage low level	V_{OUTL}	$V_{VCCIO} = 3.3\text{V}$			0.4	V
Output voltage high level	V_{OUTH}	$V_{VCCIO} = 3.3\text{V}$	2.64			V
Output driver strength standard	I_{OUT_DRV}			4		mA
Output driver strength LED outputs	I_{OUT_LED}			8		mA
Driver strength NRESET I/O pin	I_{OUT_RST}	Driven by internal undervoltage detectors High/Low	± 5	± 30		μA

Table 215: Digital I/Os DC Characteristics

9 Manufacturing Data

9.1 Package Dimensions

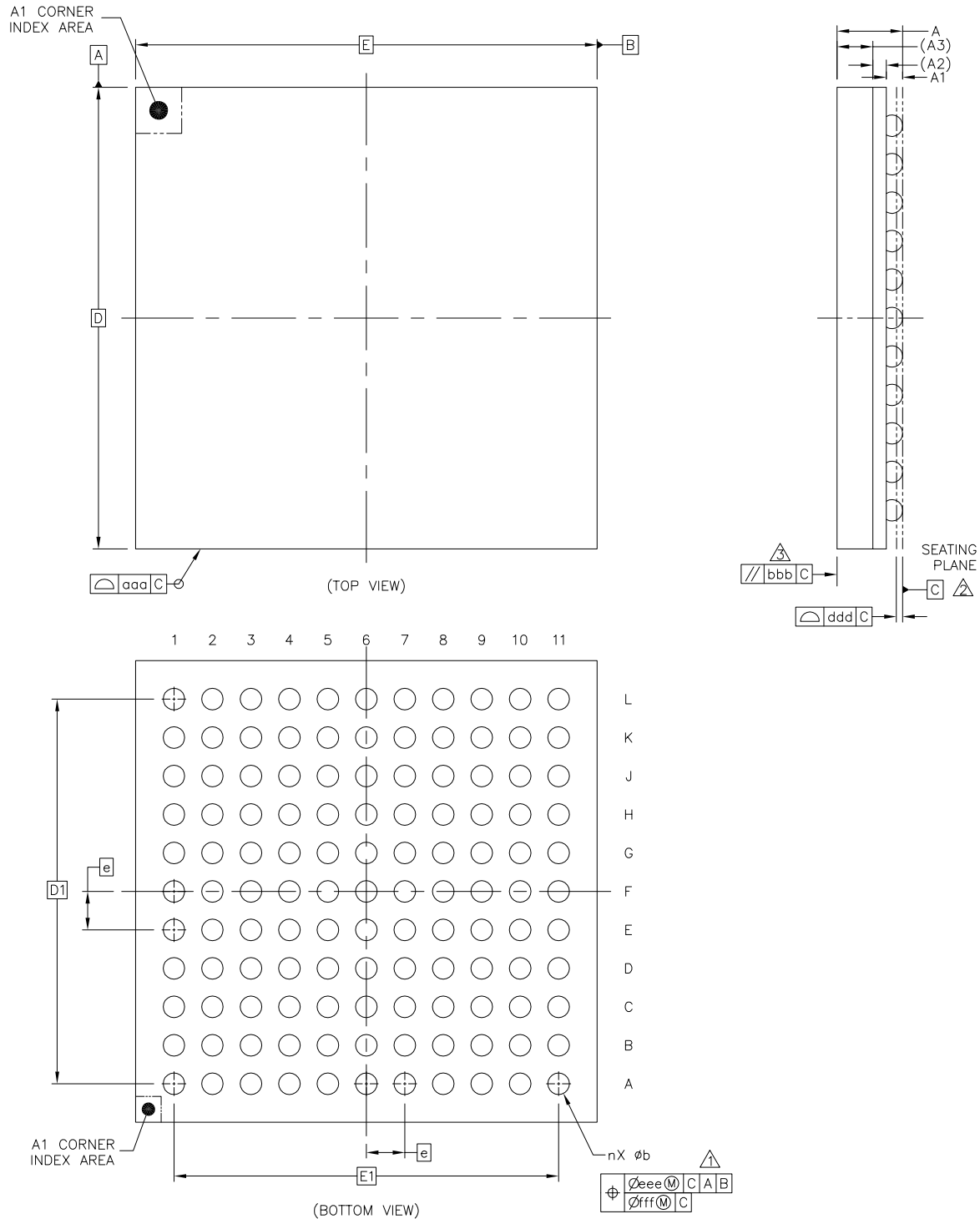

Figure 53: TMC8462A-BA package outline drawing

	Symbol	Min	Normal	Max
Total thickness	A	—	—	1.4
Stand off	A1	0.27	—	0.37
Substrate thickness	A2		0.26	REF
Mold thickness	A3		0.7	REF
Body size	D		9	BSC
Body size	E		9	BSC
Ball diameter			0.4	
Ball Opening			0.3	
Ball width	b	0.37	—	0.47
Ball pitch	e		0.75	BSC
Ball count	n		121	
Edge ball center to center	D1		7.5	BSC
Edge ball center to center	E1		7.5	BSC
Body center to contact ball	SD		—	BSC
Body center to contact ball	SE		—	BSC
Package edge tolerance	aaa		0.1	
Mold flatness	bbb		0.2	
Coplanarity	ddd		0.12	
Ball offset (package)	eee		0.15	
Ball offset (ball)	fff		0.08	

Table 216: Dimensions of TMC8462A-BA

9.2 Marking

The device marking is shown below.

Pin 1 location is highlighted with a dot.

YYWW = date code.

LLLLL = Lot number.



Figure 54: TMC8462A-BA device marking

10 Abbreviations

Abbreviation	Description
MCU	Microcontroller unit, application controller
AL	Application Layer
ASIC	Application Specific Integrated Circuit
CoE	CAN application protocol over EtherCAT
COMM	Common Anode or common cathode
CPU	Central Processing Unit
DC	Distributed Clocks
DPRAM	Dual Ported Random Access Memory
ECAT	EtherCAT
ENI	EtherCAT Network Information (Information on Network configuration in XML format)
EOF	End of Frame
ESC	EtherCAT Slave Controller
ESI	EtherCAT Slave Information (device description/configuration data in XML format)
ESM	EtherCAT State Machine
ETG	EtherCAT Technology Group
EtherCAT	Ethernet for Control Automation Technology
FMMU	Fieldbus Memory Management Unit
FoE	File Access over EtherCAT
GPIO	General Purpose I/O
GPI	General Purpose Input
GPO	General Purpose Output
IDE	Integrated Development Environment
IEC	International Electrotechnical Commission
IRQ	Interrupt Request
LED	Light Emitting Diode
MI	(PHY) Management Interface
MII	Media Independent Interface
MISO	Master In - Slave Out
MOSI	Master Out - Slave In
PDI	Process Data Interface
PDO	Process Data Object
PDRAM	Process Data Random Access Memory

POF	Passive Optical Fiber
RMS	Root Mean Square value
SII	Slave Information Interface
SM	SyncManager
SOF	Start of Frame
SPI	Serial Peripheral Interface
TMCL	TRINAMIC Motion Control Language
(S)TPC	(Shielded) Twisted Pair Copper
TTL	Transistor Transistor Logic
UART	Universal Asynchronous Receiver Transmitter
USB	Universal Serial Bus
XML	Extended Mark-up Language

Table 217: Abbreviations used in this Manual

11 Figures Index

1	General device architecture	7	28	Status LED circuit	38
2	TMC8462A Evaluation Board	11	29	SII EEPROM circuit (shown for EEPROMs >32kBit)	39
3	TMC8462 breakout board for RJ45 and TPC	12	30	Direct PHY to PHY connection	39
4	TMCL-IDE	12	31	MFC IO Block Configuration using the ESC Parameter RAM	111
5	Configuration wizard example – MFC IO block configuration	13	32	MFC IO Crossbar Example Configuration	151
6	Configuration wizard example – SII EEPROM content and C-code output	14	33	MFC IO ESI/XML Configuration Block	159
7	TMC8462A-BA Pinout top view	15	34	MFC IO Incremental Encoder Unit	160
8	PDI control signals	23	35	Block structure of SPI Master Unit	162
9	PDI SPI 2 byte addressing	24	36	Block structure of SPI Master Unit	167
10	PDI SPI 3 byte addressing	25	37	Block structure of the MFC IO Step and Direction Block	171
11	SPI timing example	26	38	Step & Direction Signal Timing	172
12	MFC control signals	27	39	Block structure of the MFC IO PWM Block	174
13	MFC CTRL SPI 2 byte addressing	28	40	PWM chopper modes	176
14	MFC CTRL SPI 3 byte addressing	28	41	PWM Timing (centered PWM)	177
15	MFC SPI timing example	28	42	PWM Timing (left aligned PWM)	177
16	SPI bus sharing	29	43	PWM Timing (right aligned PWM)	178
17	Physical bus interface pins	30	44	PWM BBM Timing	178
18	Minimum external circuit for power-on reset	31	45	Centered PWM with PWM channel 2 shifted from center (example showing only 3 PWM channels)	179
19	PLL supply filter	31	46	RC filter for DAC output with example values	180
20	PHY power regulator filtering	32	47	Block structure of GPIO Unit	181
21	External circuit for switching regulator 0 with $V_{S0} = 5V$	33	48	Block structure of the MFC IO IRQ Block	182
22	External circuit for switching regulator 0 with $V_{S0} > 5V$	33	49	Logical position of the MFC IO watchdog unit between crossbar and MFCIOxx pins	183
23	External circuit for adjustable buck regulator	34	50	Structure of the MFC IO watchdog unit	184
24	Minimum external supply circuit for single 3.3V supply	35	51	Schematic of multi voltage I/O port	188
25	Minimum external supply circuit for single 5V supply	36	52	Internal schematic and external components for both switching regulators	190
26	Minimum external supply circuit for single supply >5V	37	53	TMC8462A-BA package outline drawing	196
27	Typical power supply chain using both buck converters	38	54	TMC8462A-BA device marking	198

12 Tables Index

1	TMC8462A order codes	6	47	Register 0x030D (PDI Err Cnt)	72
2	Pin and Signal description for TMC8462A-BA	22	48	Register 0x030E (PDI Err Code)	72
3	PDI signal description	24	49	Register 0x0310:0x0313 (LL Counter)	73
4	PDI SPI commands	24	50	Register 0x0400:0x0401 (WD Divider)	74
5	MFC CTRL SPI signal description	27	51	Register 0x0410:0x0411 (WD Time PDI)	74
6	Physical bus interface pin description	30	52	Register 0x0420:0x0421 (WD Time PD)	74
7	Available EtherCAT Chip Features (0 = not available/disabled, 1 = available/enabled)	42	53	Register 0x0440:0x0441 (WD Status PD)	75
8	TMC8462A EtherCAT Registers	48	54	Register 0x0442 (WD Counter PD)	75
9	Register 0x0000 (Type)	49	55	Register 0x0443 (WD Counter PDI)	76
10	Register 0x0001 (Revision)	49	56	SII EEPROM Interface Register Overview	77
11	Register 0x0002 (Build)	49	57	Register 0x0500 (PROM Config)	77
12	Register 0x0004 (FMMUs)	50	58	Register 0x0501 (PROM PDI Access)	77
13	Register 0x0005 (SMs)	50	59	Register 0x0502:0x0503 (PROM Cntrl)	79
14	Register 0x0006 (RAM Size)	50	60	Register 0x0504:0x0507 (PROM Address)	79
15	Register 0x0007 (Port Descriptor)	51	61	Register 0x0508:0x050F (PROM Data)	80
16	Register 0x0008:0x0009 (ESC Features)	52	62	Register 0x0580:0x05E1 (MFC IO Config)	81
17	Register 0x0010:0x0011 (Station Addr)	53	63	MII Management Interface Register Overview	82
18	Register 0x0012:0x0013 (Station Alias)	53	64	Register 0x0510:0x0511 (MI Cntrl/State)	83
19	Register 0x0020 (Write Register Enable)	54	65	Register 0x0512 (PHY Address)	83
20	Register 0x0021 (Write Register Prot.)	54	66	Register 0x0513 (PHY Register Address)	84
21	Register 0x0030 (ESC Write Enable)	54	67	Register 0x0514:0x0515 (PHY Data)	84
22	Register 0x0031 (ESC Write Prot.)	55	68	Register 0x0516 (MI ECAT State)	84
23	Register 0x0040 (ESC Reset ECAT)	56	69	Register 0x0517 (MI PDI State)	85
24	Register 0x0041 (ESC Reset PDI)	56	70	Register 0x0518+y (PHY Port Status)	85
25	Register 0x0100:0x0103 (DL Control)	58	71	FMMU Register Overview	86
26	Register 0x0108:0x0109 (R/W Offset)	58	72	Register 0x06y0:0x06y3 (Log Start Addr)	86
27	Register 0x0110:0x0111 (DL Status)	60	73	Register 0x06y4:0x06y5 (FMMU Length)	86
28	Decoding port state in ESC DL Status register 0x0111 (typical modes only)	60	74	Register 0x06y6 (Log. Start Bit)	87
29	Register 0x0120:0x0121 (AL Cntrl)	61	75	Register 0x06y7 (Log. Stop Bit)	87
30	Register 0x0130:0x0131 (AL Status)	62	76	Register 0x06y8:0x06y9 (Phy. Start Addr)	87
31	Register 0x0134:0x0135 (AL Status Code)	62	77	Register 0x06yA (Phy. Start Bit)	87
32	Register 0x0138 (RUN LED Override)	63	78	Register 0x06yB (FMMU Type)	88
33	Register 0x0139 (ERR LED Override)	63	79	Register 0x06yC (FMMU Activate)	88
34	Register 0x0140 (PDI Control)	64	80	Register 0x06yD:0x06yF (Reserved)	88
35	Register 0x0141 (ESC Config)	64	81	SyncManager Register Overview	89
36	Register 0x014E (PDI Information)	65	82	Register 0x0800+y*8:0x0801+y*8 (Phy. Start Addr)	89
37	Register 0x0150 (PDI SPI CFG)	66	83	Register 0x0802+y*8:0x0803+y*8 (SM Length)	89
38	Register 0x0151 (SYNC/LATCH CFG)	67	84	Register 0x0804+y*8 (SM Control)	90
39	Register 0x0152:0x0153 (PDI SPI extCFG)	67	85	Register 0x0805+y*8 (SM Status)	91
40	Register 0x0200:0x0201 (ECAT Event M.)	68	86	Register 0x0806+y*8 (SM Activate)	91
41	Register 0x0204:0x0207 (AL Event Mask)	68	87	Register 0x0807+y*8 (SM PDI Control)	92
42	Register 0x0210:0x0211 (ECAT Event R.)	69	88	Register 0x0900:0x0903 (Rcv Time P0)	93
43	Register 0x0220:0x0223 (AL Event R.)	70	89	Register 0x0904:0x0907 (Rcv Time P1)	93
44	Register 0x0300:0x0307 (RX Err Cnt)	71	90	Register 0x0910:0x0917 (System Time)	94
45	Register 0x0308:0x030B (FW RX Err Cnt)	71	91	Register 0x0918:0x091F (Rcv Time EPU)	95
46	Register 0x030C (Proc. Unit Err Cnt)	71	92	Register 0x0920:0x0927 (Sys Time Offset)	95

93	Register 0x0928:0x092B (Sys Time Delay)	95	134	MFC IO Register 9 – SPI_STATUS	119
94	Register 0x092C:0x092F (Sys Time Diff)	95	135	MFC IO Register 10 – SPI_LENGTH	119
95	Register 0x0930:0x0931 (Speed Cnt Start)	96	136	MFC IO Register 11 – SPI_TIME	119
96	Register 0x0932:0x0933 (Speed Cnt Diff)	96	137	MFC IO Register 12 – I2C_TIMEBASE	120
97	Register 0x0934 (Sys Time Diff Filter)	97	138	MFC IO Register 13 – I2C_CONTROL	120
98	Register 0x0935 (Speed Cnt Filter Depth)	97	139	MFC IO Register 14 – I2C_STATUS	120
99	Register 0x0980 (Cyclic Unit Cntrl)	98	140	MFC IO Register 15 – I2C_ADDRESS	121
100	Register 0x0981 (SYNC Out Activation)	99	141	MFC IO Register 16 – I2C_DATA_R	121
101	Register 0x0982:0x0983 (SYNC Pulse Length)	100	142	MFC IO Register 17 – I2C_DATA_W	121
102	Register 0x0984 (Activation Status)	100	143	MFC IO Register 18 – SD_CH0_STEPRATE1	122
103	Register 0x098E (SYNC0 Status)	100	144	MFC IO Register 19 – SD_CH1_STEPRATE1	122
104	Register 0x098F (SYNC1 Status)	101	145	MFC IO Register 20 – SD_CH2_STEPRATE1	122
105	Register 0x0990:0x0997 (Start Time Cyclic Operation)	101	146	MFC IO Register 21 – SD_CH0_STEP_COUNT1	123
106	Register 0x0998:0x099F (Next SYNC1)	101	147	MFC IO Register 22 – SD_CH1_STEP_COUNT1	123
107	Register 0x09A0:0x09A3 (SYNC0 Cycle Time)	102	148	MFC IO Register 23 – SD_CH2_STEP_COUNT1	123
108	Register 0x09A4:0x09A7 (SYNC1 Cycle Time)	102	149	MFC IO Register 24 – SD_CH0_STEPTARGET1	123
109	Register 0x09A8 (Latch0 Control)	103	150	MFC IO Register 25 – SD_CH1_STEPTARGET1	124
110	Register 0x09A9 (Latch1 Control)	103	151	MFC IO Register 26 – SD_CH2_STEPTARGET1	124
111	Register 0x09AE (Latch0 Status)	104	152	MFC IO Register 27 – SD_CH0_COMPARE1	124
112	Register 0x09AF (Latch1 Status)	104	153	MFC IO Register 28 – SD_CH1_COMPARE1	125
113	Register 0x09B0:0x09B7 (Latch0 Time Pos Edge)	105	154	MFC IO Register 29 – SD_CH2_COMPARE1	125
114	Register 0x09B8:0x09BF (Latch0 Time Neg Edge)	105	155	MFC IO Register 30 – SD_CH0_NEXTSR	125
115	Register 0x09C0:0x09C7 (Latch1 Time Pos Edge)	106	156	MFC IO Register 31 – SD_CH1_NEXTSR	125
116	Register 0x09C8:0x09CF (Latch1 Time Neg Edge)	106	157	MFC IO Register 32 – SD_CH2_NEXTSR	126
117	Register 0x09F0:0x09F3 (ECAT Buffer Change Event Time)	107	158	MFC IO Register 33 – SD_STEPLength	126
118	Register 0x09F8:0x09FB (PDI Buffer Start Event Time)	107	159	MFC IO Register 34 – SD_DELAY	126
119	Register 0x09FC:0x09FF (PDI Buffer Change Event Time)	107	160	MFC IO Register 35 – SD_CFG	127
120	Register 0x0E00:0x0E07 (Product ID)	108	161	MFC IO Register 36 – PWM_CFG	128
121	Register 0x0E08:0x0E0F (Vendor ID)	108	162	MFC IO Register 37 – PWM1	129
122	Process Data RAM (0x1000:0xFFFF)	109	163	MFC IO Register 38 – PWM2	129
123	Process Data RAM Size	109	164	MFC IO Register 39 – PWM3	129
124	MFC IO Register Overview for TMC8462A-BA	114	165	MFC IO Register 40 – PWM4	129
125	MFC IO Register 0 – ENC_MODE	115	166	MFC IO Register 41 – PWM1_CNTRSHFT	130
126	MFC IO Register 1 – ENC_STATUS	116	167	MFC IO Register 42 – PWM2_CNTRSHFT	130
127	MFC IO Register 2 – X_ENC (write)	116	168	MFC IO Register 43 – PWM3_CNTRSHFT	130
128	MFC IO Register 3 – X_ENC (read)	116	169	MFC IO Register 44 – PWM4_CNTRSHFT	130
129	MFC IO Register 4 – ENC_CONST	116	170	MFC IO Register 45 – PWM_PULSE_B_PULSE_A1	131
130	MFC IO Register 5 – ENC_LATCH	117	171	MFC IO Register 46 – PWM_PULSE_LENGTH1	131
131	MFC IO Register 6 – SPI_RX_DATA	118	172	MFC IO Register 47 – GPO	132
132	MFC IO Register 7 – SPI_TX_DATA	118	173	MFC IO Register 48 – GPI	132
133	MFC IO Register 8 – SPI_CONF	119	174	MFC IO Register 49 – GPIO_CONFIG	132
			175	MFC IO Register 50 – DAC_VAL	133
			176	MFC IO Register 51 – MFCIO_IRQ_CFG	134
			177	MFC IO Register 52 – MFCIO_IRQ_FLAGS	135
			178	MFC IO Register 53 – WD_TIME	136
			179	MFC IO Register 54 – WD_CFG	136
			180	MFC IO Register 55 – WD_OUT_MASK_POL	137
			181	MFC IO Register 56 – WD_OE_POL	137
			182	MFC IO Register 57 – WD_IN_MASK_POL	138
			183	MFC IO Register 58 – WD_MAX	138
			184	MFC IO Register 59 – HV_ANA_STATUS	139
			185	MFC IO Register 63 – SYNC1_SYNC0_EVENT_CNT1	139
			186	MFC IO Register 64 – HVIO_CFG	140
			187	MFC IO Register 65 – BUCK_CONV_CFG	142

188	MFC IO Register 66 – AL_OVERRIDE	143	206	GPO signal output states	181
189	EEPROM Parameter Map	147	207	MFC IO watchdog WD_OUT_MASK_POL signal/port assignment	185
190	Crossbar configuration values	150	208	MFC IO watchdog WD_IN_MASK_POL signal/port assignment	186
191	Slope Slow/Weak High/WeakLow config	152	209	Differential input combination table .	189
192	Differential HV input configuration . .	152	210	Switching regulator component selec- tion for L and C	190
193	Configuration bits for 3.3V switching regulator	153	211	Absolute Maximum Ratings for TMC8462A-BA	192
194	Configuration bits for adjustable switching regulator	154	212	Operational Ratings for TMC8462A-BA	193
195	Register mapping example	155	213	High Voltage I/O Block DC Character- istics	194
196	Register configuration byte	157	214	Switching Regulator DC Characteristics	195
197	Trigger source descriptions	158	215	Digital IOs DC Characteristics	195
198	SPI mode configuration	163	216	Dimensions of TMC8462A-BA	197
199	I2C control commands	167	217	Abbreviations used in this Manual . .	200
200	I2C status register bits	168	218	IC Revision	205
201	I2C status overview	168	219	Document Revision	205
202	I2C Address register	169			
203	Step and direction unit parameters .	172			
204	PWM unit parameters	175			
205	PWM modes	175			

13 Revision History

13.1 IC Revision

Version	Date	Author	Description
V2.0	20.06.2019	-	V2.0, based on TMC8462-BA

Table 218: IC Revision

13.2 Document Revision

Version	Date	Author	Description
V1.00	23.12.2021	SK	<ul style="list-style-type: none"> - Initial release based on TMC8462-BA data sheet - Order codes updated in Table 1. - Temperature ratings corrected based on PHY specs in Table 212. - Description of memory block mapping updated throughout Section 7 and in Section 7.8. - ESD ratings updated in Table 211. - Updated block diagram for PLL supply filter to reflect TMC8462A-BA changes in Figure 19.
V1.10	29.08.2022	SK	<ul style="list-style-type: none"> - Updated package marking picture in Figure 54. - Pin L3 name and description changed from REF_CLK100_IN to REF_CLL25_IN. See Section 4.2. Figure 1 and description updated accordingly. - Pin descriptions for switching regulators 0 and 1 extended in pin table in Section 4.2

Table 219: Document Revision