

© - TE Connectivity. All Rights Reserved.

REVISIONS				
P	LTR	DESCRIPTION	DATE	APVD
	V2	REVISED PER ECN-22-156403	03JUN2022	RK CSD

300 VOLT MAX		
AMP WIRE RANGE	Listed FILE E13288	LR7189 Certified
12-10 AWG SOLID OR STRANDED	12-10 AWG SOLID OR STRANDED	12-10 AWG SOLID OR STRANDED

300 VOLT MAX		
AMP WIRE RANGE	Listed FILE E13288	LR7189 Certified
12-10 AWG STRANDED	12-10 AWG STRANDED	12-10 AWG STRANDED

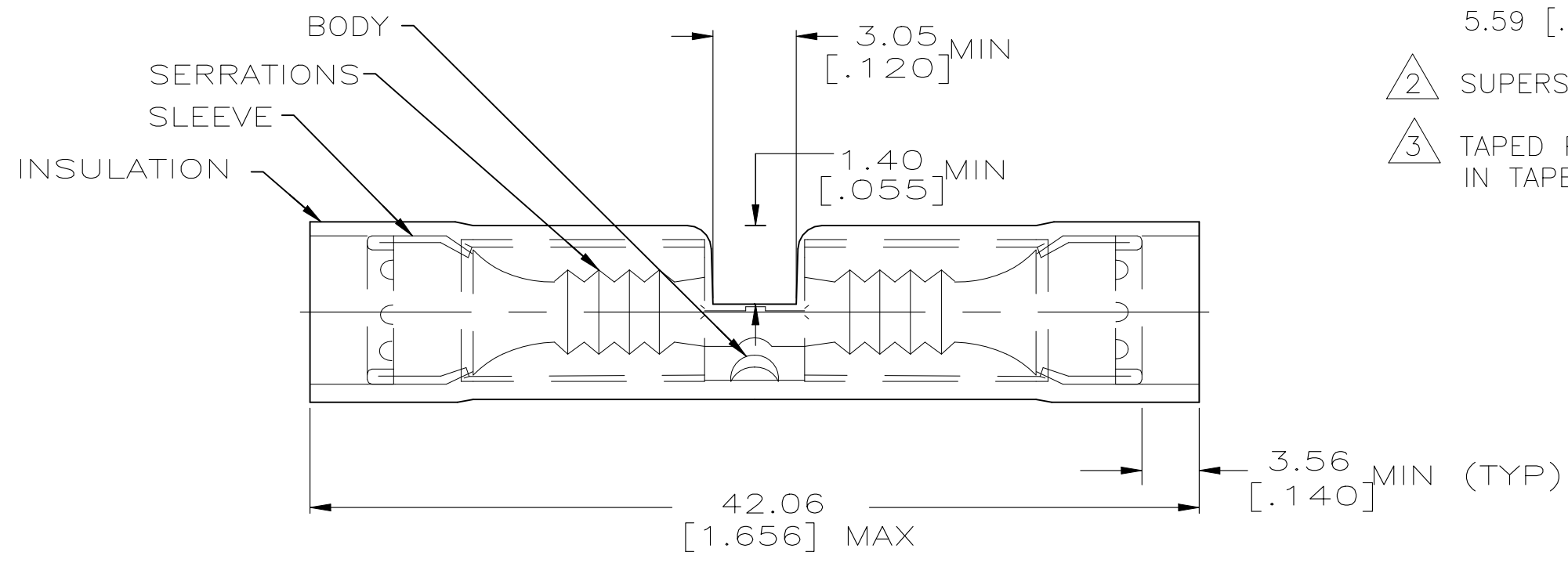

- 1 WIRE INSULATION DIA 3.81 [.150] TO 5.59 [.220].
- 2 SUPERSEDED BY 8-320570-2
- 3 TAPED PART LONG, CRIMP ONLY IN TAPETRONICS.

MILITARY PART NUMBER & CLASS PER MIL-T-7928	QTY	PACKAGE TYPE	PART NUMBER
-	1000	BULK, LOOSE PIECE	8-320570-5
-	1500	ON TAPE, REEL	3 2-320570-3
-	5	LOOSE PIECE, BLS	8-320570-4 2
-	50	LOOSE PIECE, BOX	8-320570-2
M7928/5-5 CLASS 1	50	LOOSE PIECE	320570

AMP INCORPORATED
CUSTOMER SERVICE SYSTEMS

FOR ADDITIONAL PRODUCT INFORMATION OR COPIES OF DRAWINGS AND TECHNICAL DOCUMENTS
PRODUCT INFORMATION CENTER
1-800-522-6752

FOR APPLICATION TOOLING ASSISTANCE CENTER
TOOLING INFORMATION
1-800-722-1111

FOR ORDER ENTRY
1-800-526-5142

MAX RECOMMENDED OPERATING TEMPERATURE:
105° C

VOLTAGE RATING:
600V MAX
1000V MAX (FIXTURE OR SIGN)

CIRCULAR MIL AREA:
2.62-6.64mm² [5,180-13,100]

THIS DRAWING IS A CONTROLLED DOCUMENT FOR AMP INCORPORATED. IT IS SUBJECT TO CHANGE AND THE CONTROLLING ENGINEERING ORGANIZATION SHOULD BE CONTACTED FOR THE LATEST REVISION.

THIS DRAWING IS A CONTROLLED DOCUMENT.

DIMENSIONS:
MM [INCHES]

TOLERANCES UNLESS OTHERWISE SPECIFIED:

0 PLC	± -
1 PLC	± -
2 PLC	± 0.20 [.008]
3 PLC	± -
4 PLC	± -
ANGLES	± -

MATERIAL: COPPER ASTM B-152
FINISH: TIN PLATE

DWN: S.S. GOULDEN 9-28-93
CHK: R. HERSEY 9-28-93
APVD: T. MICHELUTTI 9-28-93

STE TE Connectivity

NAME: SPLICE, BUTT, PIDG, WIRE SIZE: 12-10 AWG

SIZE: A3 CAGE CODE: 00779 DRAWING NO: C-320570 RESTRICTED TO: -

WEIGHT: -

CUSTOMER DRAWING SCALE: 1:1 SHEET: 1 OF 1 REV: V2