

DO NOT SCALE FROM THIS PRINT

DESIGNED & DIMENSIONED IN MILLIMETERS [INCHES]

UPS-XX-01-XX-X-RA-XX-XX

No OF POSITIONS
 -02: 2 POSITIONS
 -04: 4 POSITIONS
 -06: 6 POSITIONS
 -08: 8 POSITIONS

PACKAGING
 BLANK: TUBES (SEE NOTE 7 & 8)
 -TR: TAPE & REEL (SEE NOTES 8 & 9)
 -FR: FULL REEL QTY TAPE & REEL (SEE NOTES 8 & 9)

LEAD STYLE

-01

OPTION

-LC: LOCKING CLIP

RIGHT ANGLE

TAIL LENGTH

-01: FOR 1.57[.062] THICK PCB (USE SUB-C-263-01-X) (SEE FIG. 1)
 -02: FOR 2.36[.093] THICK PCB (USE SUB-C-263-02-X) (SEE FIG. 2)

PLATING

-L: LIGHT SELECTIVE, 10 AU/50 NI MIN ON CONTACT, TIN ON TAIL
 -T: TIN, TIN ALL OVER

* = NOT TOOLED

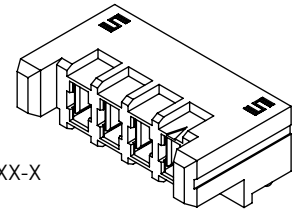
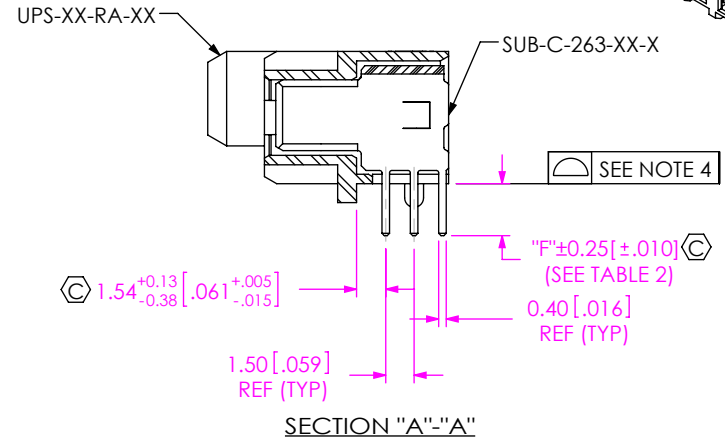
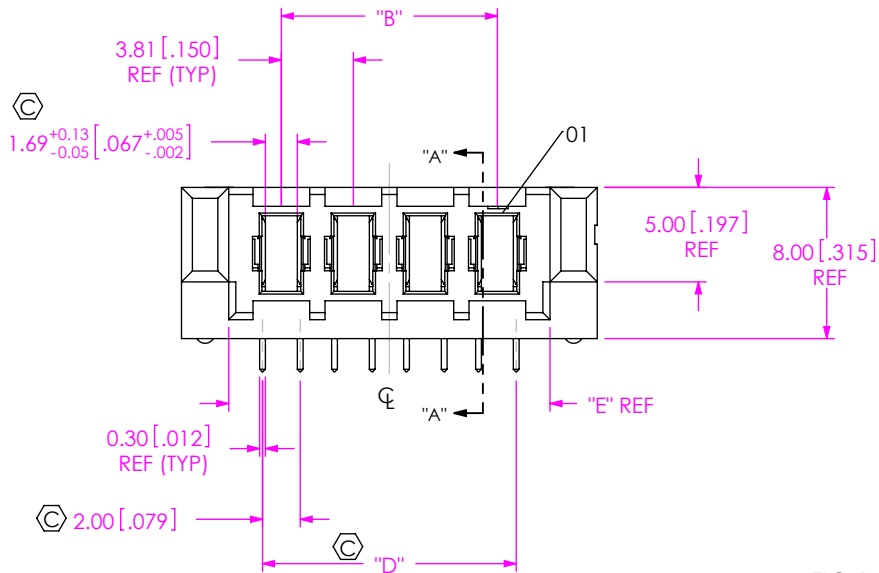
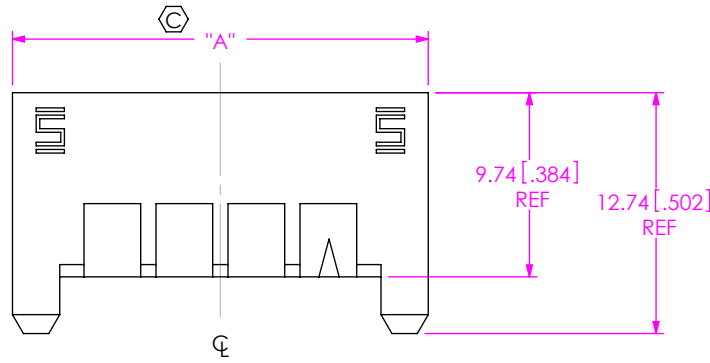

FIG 1 (UPS-04-01-X-RA SHOWN)

PART NUMBER	"A"	"B"	"C"	"D"	"E"
UPS-02-XX-X-RA-XX	14.38 [.566]	3.81 [.150]	11.88 [.468]	5.82 [.229]	9.38 [.369]
UPS-04-XX-X-RA-XX	22.00 [.866]	11.43 [.450]	19.50 [.768]	13.44 [.529]	17.00 [.669]
UPS-06-XX-X-RA-XX	29.62 [1.166]	19.05 [.750]	27.12 [1.068]	21.06 [.829]	24.62 [.969]
UPS-08-XX-X-RA-XX	37.24 [1.466]	26.67 [1.050]	34.74 [1.368]	28.68 [1.129]	32.24 [1.269]

TAIL LENGTH	"F"	SUB-C-XXX-XX-X
-01	2.82 [0.111]	SUB-C-263-01-X
-02	3.58 [0.141]	SUB-C-263-02-X

NOTES:

1. Ⓢ REPRESENTS A CRITICAL DIMENSION.
2. NOTE DELETED.
3. MINIMUM PUSHOUT FORCE: 4.5N [1.0 LB].
4. MAXIMUM BOW: .15 [.006].
5. MINIMUM -LC PULL OUT FORCE: 2.23 N [0.5LB].
6. NOTE DELETED.
7. TUBES ARE STANDARD PACKAGING.
8. ORDERS WILL BE PACKAGED ACCORDING TO THE SAMTEC PACKAGING EFFICIENCY STANDARDS (SPES) FOUND ON WWW.SAMTEC.COM.
9. ATTACH LABEL TO EACH REEL.

UNLESS OTHERWISE SPECIFIED, DIMENSIONS ARE IN MILLIMETERS.
 TOLERANCES ARE:
 DECIMALS ANGLES
 X.X: ±0.3 [.01] 2°
 X.XX: ±0.13 [.005]
 X.XXX: ±0.051 [.0020]

PROPRIETARY NOTE
 THIS DOCUMENT CONTAINS CONFIDENTIAL AND PROPRIETARY INFORMATION AND ALL DESIGN, MANUFACTURING, REPRODUCTION, USE, PATENT RIGHTS AND SALES RIGHTS ARE EXPRESSLY RESERVED BY SAMTEC, INC. THIS DOCUMENT SHALL NOT BE DISCLOSED, IN WHOLE OR PART, TO ANY UNAUTHORIZED PERSON OR ENTITY NOR REPRODUCED, TRANSFERRED OR INCORPORATED IN ANY OTHER PROJECT IN ANY MANNER WITHOUT THE EXPRESS WRITTEN CONSENT OF SAMTEC, INC.

MATERIAL: DO NOT SCALE DRAWING
 INSULATOR: LCP, COLOR: BLACK UL 94 VO
 TERMINAL: BeCu
 LOCKING CLIP: PHOS BRONZE

SHEET SCALE: 2:5:1



520 PARK EAST BLVD, NEW ALBANY, IN 47150
 PHONE: 812-944-6733 FAX: 812-948-5047
 e-Mail: info@SAMTEC.com code: 55322

DESCRIPTION: UPS-RA, ASSEMBLY
 DWG. NO. UPS-XX-01-XX-X-RA-XX-XX
 BY: B RAY 10/09/2008 SHEET 1 OF 2

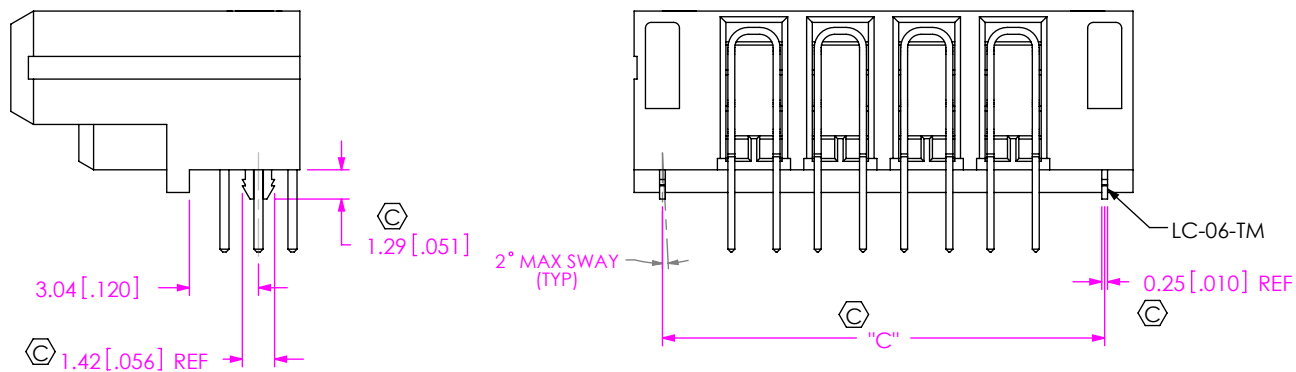
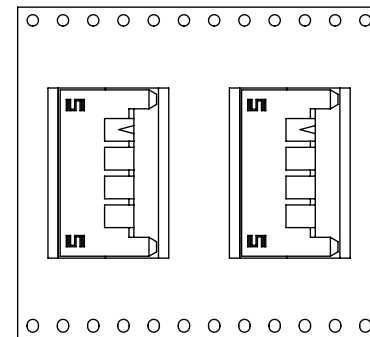
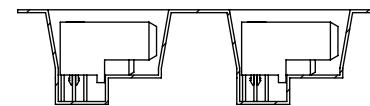

FIG 2
(UPS-04-01-X-RA-LC SHOWN)
(SAME AS FIG. 1, DIFFERENT AS SHOWN)

TABLE 3		
PLATING	POWER PIN CONTACT AREA	POWER PIN TAIL
-L	LIGHT GOLD	MATTE TIN
-T	MATTE TIN	MATTE TIN



USER DIRECTION OF UN-REELING →
POCKET NOT DETAILED



PACKAGING VIEW

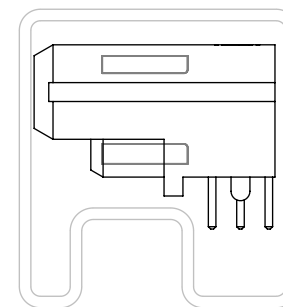

PACKAGING TUBE VIEW

TUBE TABLE		
TAIL LENGTH	TUBE	PLUG
ALL	PT-1-24-01-40	TP-13

PROPRIETARY NOTE
THIS DOCUMENT CONTAINS CONFIDENTIAL AND PROPRIETARY INFORMATION AND ALL DESIGN, MANUFACTURING, REPRODUCTION, USE, PATENT RIGHTS AND SALES RIGHTS ARE EXPRESSLY RESERVED BY SAMTEC, INC. THIS DOCUMENT SHALL NOT BE DISCLOSED, IN WHOLE OR PART, TO ANY UNAUTHORIZED PERSON OR ENTITY NOR REPRODUCED, TRANSFERRED OR INCORPORATED IN ANY OTHER PROJECT IN ANY MANNER WITHOUT THE EXPRESS WRITTEN CONSENT OF SAMTEC, INC.

DO NOT SCALE DRAWING

SHEET SCALE: 2:1



520 PARK EAST BLVD, NEW ALBANY, IN 47150
PHONE: 812-944-6733 FAX: 812-948-5047
e-Mail: info@SAMTEC.com code: 55322

DESCRIPTION: UPS-RA, ASSEMBLY
DWG. NO. UPS-XX-01-XX-X-RA-XX-XX
BY: B RAY 10/09/2008 SHEET 2 OF 2