

# Rugged Digital Networks Solutions

Reinforced Infocom Connectors for Harsh Environment

## RJ Field Cat6

**NEW**

# Amphenol



Connecting to people + technology

[www.rjfield.com](http://www.rjfield.com)

## INFORMATION ■■■■

	CAT5e	CAT6	CAT6A
Standard	ISO 11801 EIA/TIA 568	ISO 11801 EIA/TIA 568	ISO 11801 EIA/TIA 568
Data rate	1 GBit/s	1 GBit/s	10 GBit/s
Frequency	100 MHz	250 MHz	500 MHz

## OUR SOLUTIONS

Series	CAT5e	CAT6	CAT6A
RJFRB	X	X	
RJF544	X		
RJF5446	X	X	
RJFEZ	X		
RJF / RJFTV	X		
RJF6 / RJFTV6	X	X	
RJFTV ATEX	X		
RJFTV6 ATEX	X	X	
µCom-10Gb+	X	X	X
RJF6A / RJFTV6A *	X	X	X
High reliability cables & cordsets	X	X	X

\* Coming soon

Cat5e solutions ► [Download the Rugged Ethernet & USB catalogue](#)

µCom-10Gb+ Ethernet Micro Connector ► [Download the catalogue](#)

or  
visit

► [www.amphenol-socapex.com](http://www.amphenol-socapex.com)

# RUGGED ETHERNET CAT6 SOLUTIONS SELECTION GUIDE

Connectors	Series	Indust. Ethernet Spec.	Coupling Mechanism	Shape	Material	Specification	Prime Market	Page
	RJFRB		Reverse bayonet	Circular	Plastic	N/A	Industrial & Telecom	5
	RJF5446	IEC 60603-7 variant 12	Push Pull	Circular	Plastic	N/A	Industrial & Telecom	7
	RJF6	IEC 60603-7 variant 11	Bayonet	Circular	Metal	MIL-DTL-26482	Industrial Mil/Aero	9
	RJF6 CAT6 in line receptacle	IEC 60603-7 variant 11	Bayonet	Circular	Metal	MIL-DTL-26482	Industrial Mil/Aero	12
	RJF6 CAT6 transversally sealed receptacles		Bayonet	Circular	Metal	MIL-DTL-26482	Mil/Aero & Industrial	13
	RJF6 CAT6 hermetic receptacles		Bayonet	Circular	Metal	MIL-DTL-26482	Mil/Aero & Industrial	14
	RJ Field Cat 6 receptacles with self closing cap	IEC 60603-7 variant 11	Bayonet	Circular	Metal	MIL-DTL-26482	Industrial Mil/Aero	15
	RJF TV6		Thread	Circular	Metal	MIL-DTL-38999 Series III	Mil/Aero & Rail Mass Transit	18
	RJF TV6 CAT6 through bulkhead receptacles		Thread	Circular	Metal	MIL-DTL-38999 Series III	Mil/Aero & Rail Mass Transit	21
	RJF TV 6 CAT6 transversally sealed receptacles		Thread	Circular	Metal	MIL-DTL-38999 Series III	Mil/Aero & Industrial	22
	RJF TV 6 CAT6 hermetic receptacles		Thread	Circular	Metal	MIL-DTL-38999 Series III	Mil/Aero & Industrial	23
Cable	Series	Prime Market					Page	
	High reliability Cat6 cable & cordets	Mil/Aero					27	

# RUGGED ATEX ZONE 2 CAT6 SOLUTION SELECTION GUIDE

Connectors	Series	Indust. Ethernet Spec.	Coupling Mechanism	Shape	Material	Specification	Prime Market	Page
	RJF TVX6	EN60079-15	Thread	Circular	Metal	MIL-DTL-38999 Series III	Factory Automation, Video, Oil & Gas	28

# TABLE OF CONTENTS

## CAT 6 Rugged Ethernet Solutions

RJFRB - CAT6 Ethernet connection system for harsh environment - Industrial Ethernet .....	5
RJF5446 - CAT6 Ethernet connection system for harsh environment - Industrial Ethernet .....	7
RJF6 - CAT6 Ethernet connection system for harsh environment - Industrial Ethernet .....	9
RJF6 - CAT6 in line receptacle .....	12
RJF6 - CAT6 transversally sealed receptacles .....	13
RJF6 - CAT6 hermetic receptacles .....	14
RJF CAT6 receptacle with self closing cap .....	15
RJF plugs with 360° EMI backshell .....	16
RJF special plugs for big insulation wire up to 1.6 mm .....	17
RJF TV6 - CAT6 Ethernet connection system for harsh environment .....	18
RJF TV6 - CAT6 through bulkhead receptacles .....	21
RJF TV6 - CAT6 transversally sealed receptacles.....	22
RJF TV6 - CAT6 hermetic receptacles.....	23
RJFTV plugs with 360° EMI backshell .....	24
RJFTV special plugs for big insulation wire up to 1.6mm .....	25
Self closing cap (SCC) for RJF TV6/RJFTV receptacles .....	26
High reliability CAT6 Ethernet cable and cordsets .....	27

## ATEX Solutions

RJF TVX6 - CAT6 RJ45 explosion proof solution for Zone 2 .....	28
--	----

# RJF RB

CAT6 Ethernet connection system for harsh environment – Industrial Ethernet



RJFRB allows you to use an Ethernet Class E / Cat 6 connection for 10 BaseT, 100 BaseTX or 1000 BaseT up to 250 MHz networks in harsh environments. With the patented RJStop® system you can use a standard RJ45 cordset in a protective **composite** plug which will protect it from shocks, dust and fluids. **No hazardous on-field cabling and grounding!**

## Applications

- Telecom equipments
- Video control
- Robotics
- Industrial process control
- CNC machines
- Special machines
- Motion control

## Data transmission

10 BaseT, 100 BaseTX and 1000 BaseT up to 250 MHz networks  
Cat6 per EIA/TIA 568 and ClassE per ISO11801

## Main characteristics

- Sealed against fluids and dust (IP68)
- Shock, vibration and traction resistant
- No cabling operation in field, no tools required
- **Reverse bayonet coupling**
- RJ45 cordset retention in the plug: 70 N in the axis
- Mating cycles: 500 min
- Compatible with cable diameter from 5,5 mm [0.216 in] to 7 mm [0.275 in]

## Environmental protection

- Sealing: IP68
- Salt spray > 1000 h
- Fire retardant / Low smoke: UL94 V0 and NFF 16102, DIN 5510-2
- Operating temperature: - 40°C / +85°C

## Part number code

	RJF RB	7	3U
<b>Shell type</b>			
7: composite jam nut receptacle			
6: composite reverse bayonet plug, plastic gland			
<b>Back terminations (for receptacles only)</b>			
3U: IDC cat6 - unshielded			
3F: IDC cat6 - partial shielding			
3S: IDC cat6 - 100% shielded			

Examples: - receptacle, IDC cat6, unshielded ⇒ **RJF RB 73U**  
- plug ⇒ **RJF RB 6**

## Receptacle

- Type 3: IDC CAT 6 termination (rear mounting)



Unshielded: **RJF RB 73U**  
Partial shielding **RJF RB 73F**

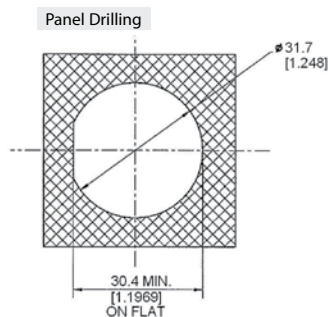

Shielded: **RJFRB73S**

Cat5e version: page 10 of the Field series catalogue.

- ▶ [Direct access by clicking here](#)
- ▶ Or visit [www.amphenol-socapex.com](http://www.amphenol-socapex.com)

## Plug

- Type 6 shell with plastic gland



RJFRB6

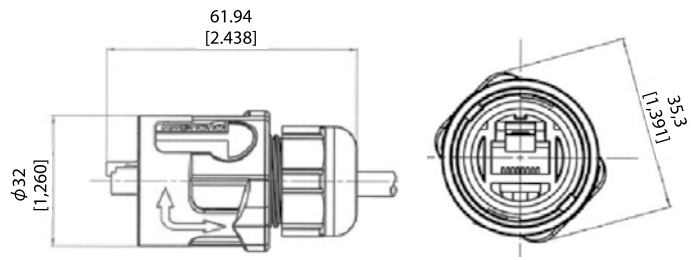

## Assembly instructions



## Accessories

- IP68 Dust caps

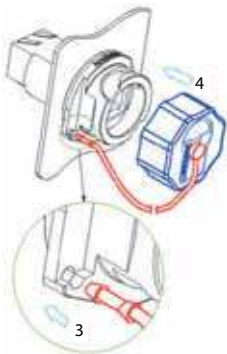

**RJF RB C7**  
Cap for receptacles RJFRB71 / 71RA / 72xxx

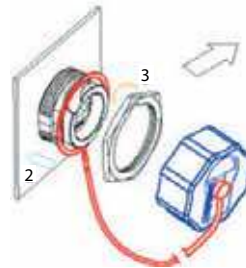

**RJF RB C75**  
Cap for receptacles RJFRB75 and RJFRB73x

# RJF 5446

## CAT6 Ethernet connection system for harsh environment – Industrial Ethernet



RJF5446 allows you to use an Ethernet Class E / Cat 6 connection for 10 BaseT, 100 Base TX or 1000 BaseT up to 250 MHz networks in harsh environments. With the patented RJStop® system you can use a standard RJ45 cordset in a protective **composite** plug which will protect it from shocks, dust and fluids. **No hazardous on-field cabling and grounding !**

- Applications**
- Telecom equipment
  - Video control
  - Robotics
  - Industrial process control
  - CNC machines
  - Special machines
  - Motion control
  - Tele-maintenance

**Data transmission**  
 10 BaseT, 100 BaseTX and 1000 BaseT up to 250 MHz networks  
 Cat6 per EIA/TIA 568 and ClassE per ISO11801



Also available with transversal sealing\*  
 \*Sealed in unmated condition

- Main characteristics**
- Compliant with IEC 60603-7 variante 12
  - Shock, vibration and traction resistant
  - No cabling operation in field and no tools required
  - Sealed against fluids and dust (IP68)
  - **Quick push pull coupling**
  - RJ45 cordset retention in the plug: 100 N in the axis
  - Mating cycles: 500 min
  - Improved EMI Protection
  - Compatible with cable diameter from 6 mm [0.236 in] to 13 mm [0.512 in]
- Environmental Protection**
- Sealing: IP68
  - Salt spray > 1000 h
  - Fire retardant / Low smoke: UL94 V0 and NFF 16102, DIN 5510-2
  - Vibrations: 10 – 500 Hz, 10 g, 3 axes: no discontinuity > 10 nano s.
  - Operating temperature: - 40°C / +85°C

**Part number code: receptacles.**

	RJF 5446	2	1
<b>Shell type</b>			
2: composite square flange receptacle			
2S: composite square flange receptacle transversally sealed			
2M: metallized (Ni) composite square flange receptacle			
2SM: metallized (Ni) composite square flange receptacle transversally sealed			
<b>Back termination</b>			
1: female RJ45			

Examples: - Square flange receptacle, female RJ45 back termination: RJF 5446 21  
 - Metallized square flange receptacle, female RJ45 back termination: RJF 5446 2M 1  
 - Transversally sealed receptacle, female RJ45 back termination: RJF5446 2S1

**Part number code: plug.**

	RJF 544	6
<b>Shell type</b>		
6: composite push pull plug, plastic gland		

Cat5e version: page 13 of the Field series catalogue.  
 ▶ [Direct access by clicking here](#)  
 ▶ Or visit [www.amphenol-socapex.com](http://www.amphenol-socapex.com)

## Receptacle

- Type 2S/2M/2SM shell: square flange receptacle with 4 mounting holes

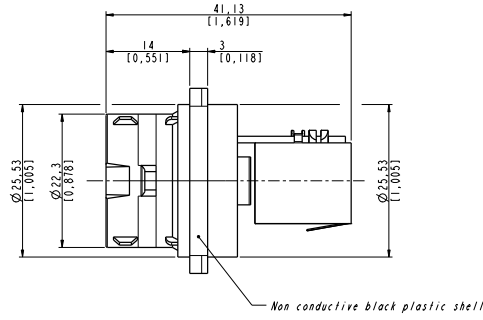

RJF 5446 2x 1

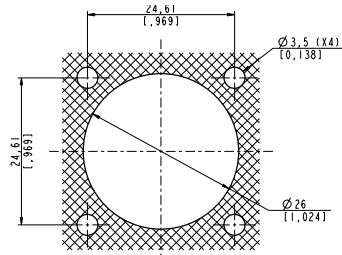
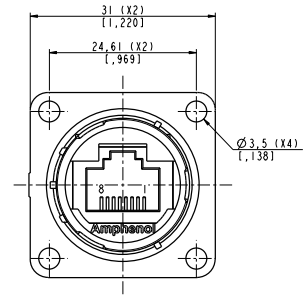

Panel drilling

## Back termination

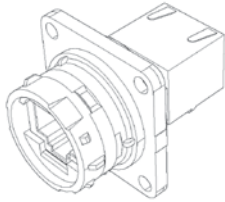

Type1: female RJ45

## Plug

- Type 6 shell with plastic gland p/n **RJF544 6**

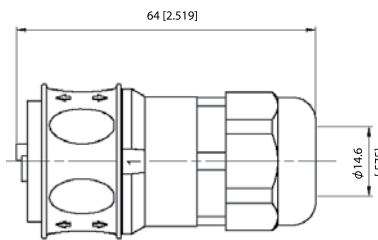

RJF 544 6

## Accessories

- Rubber IP68 receptacle cap p/n **RJF 544BESC**



- Panel gasket p/n **RJF 544 02JE**



- IP68 caps for plug p/n **544 02 BM**

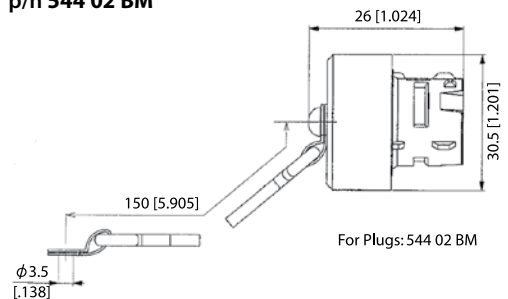

- Panel gasket (thickness: 0.6mm [0.039]): p/n **RJF 544 02 JE**
- Plug Insert removal tool: p/n **5440 OT 02**



# RJF6

## CAT6 Ethernet connection system for harsh environment – Industrial Ethernet



RJF Cat6 allows you to use an Ethernet Class E / Cat. 6 connection for 10 BaseT, 100 BaseTX or 1000 BaseT up to 250 MHz networks in harsh environments. With the patented RJStop® system you can use a standard RJ45 cordset in a **metallic** plug which will protect it from shocks, dust and fluids.  
**No hazardous on-field cabling and grounding!**

- Applications**
- Robotics
  - Industrial process control
  - CNC machines
  - Special machines
  - Oil & Gas
  - Motion control
  - Data acquisition and transmission in harsh environment
  - Tele-maintenance

**Data transmission**  
10 BaseT, 100 BaseTX and 1000 BaseT up to 250 MHz networks  
Cat 6 per EIA/TIA 568 and ClassE per ISO11801

Cat5e version: page 17 of the Field series catalogue.  
▶ [Direct access by clicking here](#)  
▶ Or visit [www.amphenol-socapex.com](http://www.amphenol-socapex.com)

- Main characteristics**
- Compliant with IEC 60603-7 variante 11
  - **Bayonet coupling** ("Audible & Visual" coupling signal)
  - **Robust metallic shells based on MIL-DTL-26482 H - Shell size 18**
  - RJ45 cordset retention in the plug: 100 N in the axis
  - Mating cycles: 500 min
  - Sealed against fluids and dust (IP68)
  - Shock, vibration and traction resistant
  - No cabling operation in field and no tools required
  - Mechanical coding / polarization (4 positions)
  - Compatible with cable diameter from 6 mm [0.236 in] to 13 mm [0.512 in]  
For smaller diameters, please consult us.
- Environmental protection**
- Sealing: IP68
  - Salt spray: 48 h with nickel plating  
> 96 h with black coating  
< 500 h with olive drab cadmium
  - Fire retardant/Low smoke: UL94 V0 and NF F 16 101 & 16 102
  - Vibrations: 10-500Hz, 10g, 3 axes: no discontinuity >10 nano s
  - Shocks: IK06 ▶ weight of 250 g drop from 40cm [15.75 in] onto connectors (mated pair)
  - Humidity: 21 days, 43°C, 98% humidity
  - Temperature range: -40°C / +85°C

**Part number code: receptacles.**

	RJF6	2	A	PE	1	B
<b>Shell type</b>						
2: square flange receptacle						
7: jam nut receptacle						
<i>Nota: also available a transversally sealed receptacle (unmated) ▶ see page 13</i>						
<b>Coding</b>						
A, B, C, or D						
<b>Backshells</b>						
PE: IP68 backshell, plastic gland						
PEM: IP68 backshell, metal gland						
Blank for receptacles without backshell						
<b>Back termination</b>						
1: female RJ45						
<b>Shell finishes</b>						
B: black coating - ROHS compliant				BZC: aluminium shell - black zinc cobalt plating		
N: nickel - ROHS compliant				ZC: aluminium shell - green zinc cobalt plating - ROHS compliant		
G: olive drab cadmium				<i>NOTA: for N,G, BZC, and ZC plating, the inserts are metallized.</i>		

*Example: square flange receptacle, coding A, female RJ45 back termination, black plating ⇒ RJF6 2 A 1 B*

**Part number code: plug ▶ see page 11.**

	RJF	6	B
<b>Shell type</b>			
6: plug, plastic gland			
6M: plug, metal gland			
<b>Shell finishes</b>			
B: black coating - ROHS compliant			BZC: aluminium shell - black zinc cobalt plating
N: nickel (note: with this version, the inserts are metallized) - ROHS compliant			ZC: aluminium shell - green zinc cobalt plating - ROHS compliant
G: olive drab cadmium (note: with this version, the inserts are metallized)			

*Example: plug with metal gland, nickel plating ⇒ RJF 6M N*

**NOTA:** also available a plug with 360° EMI backshell, and a plug for big insulation wire up to 1.6mm ▶ see pages 16 & 17.

## Receptacles

### ■ Square flange receptacle • 4 mounting holes: shell type 2

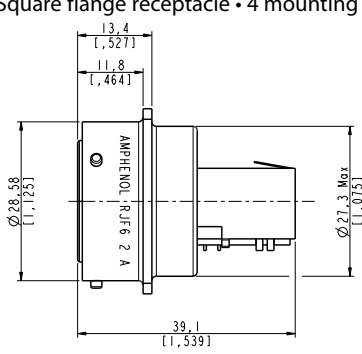

RJF6 2 X 1 X (Straight Female RJ45)

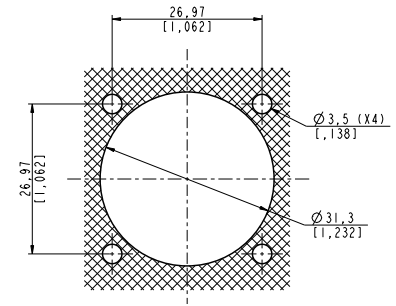
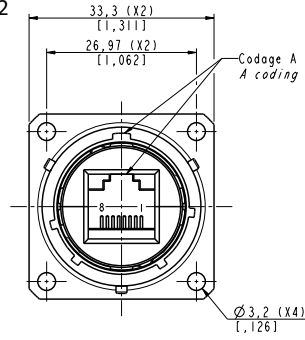

Panel Drilling

### ■ Jam nut receptacle • Hexagonal nut mounting: shell type 7

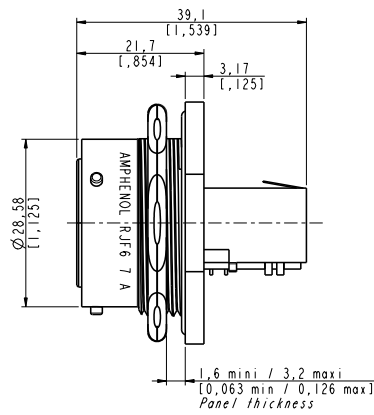

RJF6 7 x 1 X (straight female RJ45)

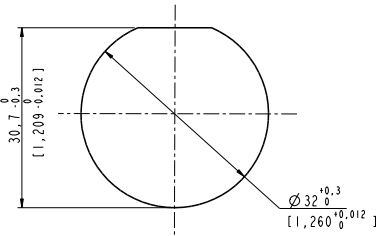
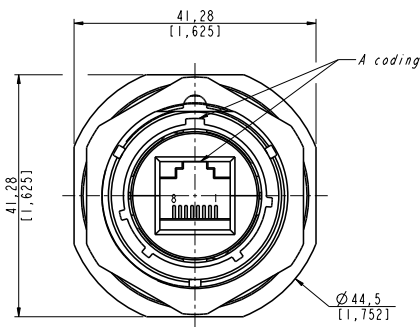

Panel drilling

### ■ Receptacles with IP68 backshell : shell type 2PE and 7PE with plastic or metal gland

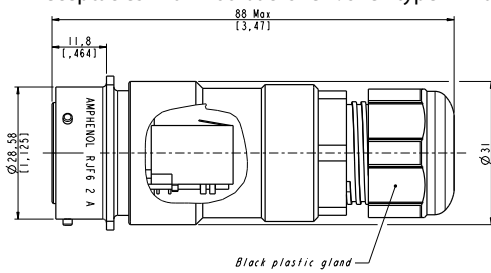

RJF6 2 X PE 1 X / 2 X PEM 1 X

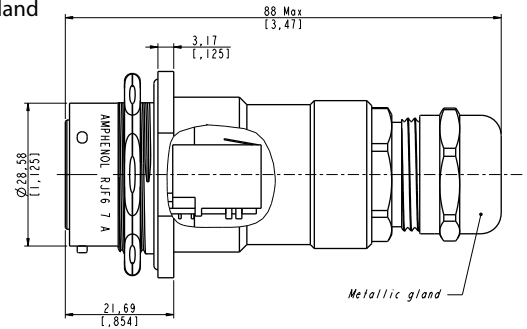

RJF6 7 X PE 1 X / 7 X PEM 1 X

## Codings - To be specified in the part number: A, B, C, or D.

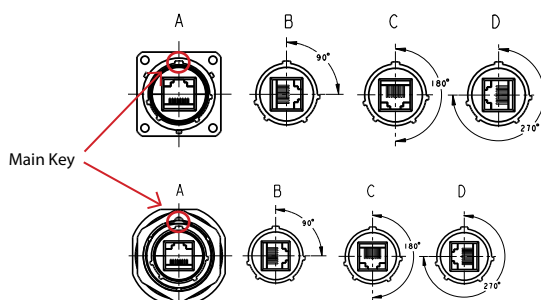

## Back termination

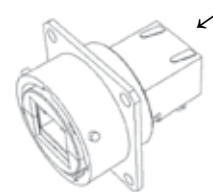

Type 1  
Female RJ45

## Plug

- Shell type 6 with plastic or metal gland

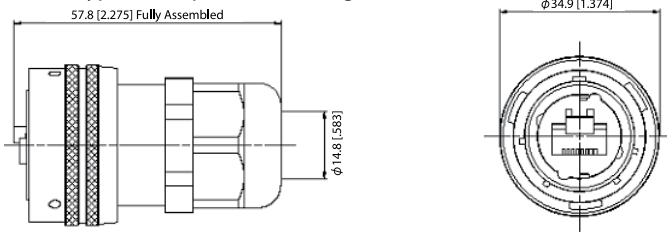

**NOTA:** also available a plug with 360° EMI backshell, and a plug for big insulation wire up to 1.6mm  
▶ see pages 16 & 17.

Universal: can be used with all standard RJ45 Cat. 6 cordset brands.

### Assembly instructions of the RJ Stop

1. Push down the RJ45 cordset latch, and fix it inside the insert
2. Press in and click the other part of the insert
3. Insert in the metallic housing

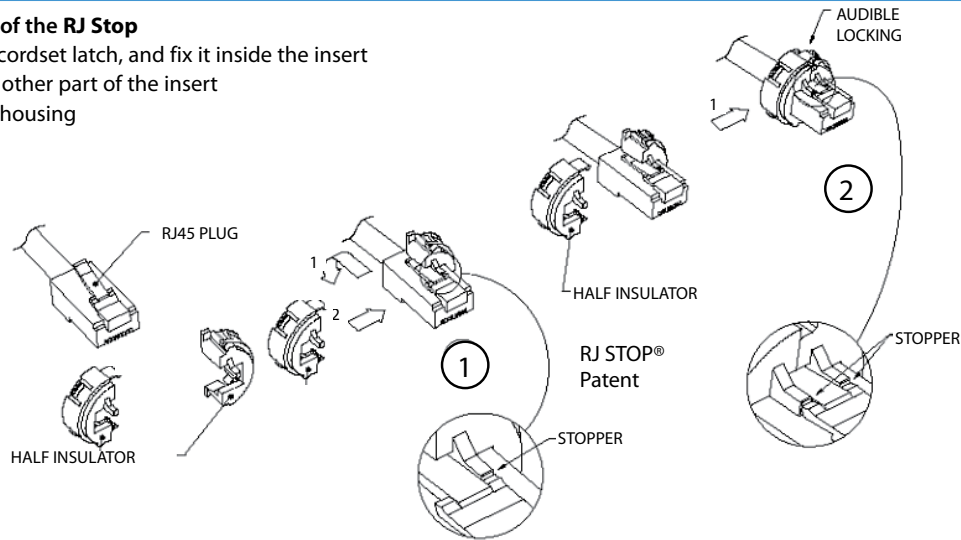

Easy and safe - No field cabling tools required for cabling

### Assembling of the plug.

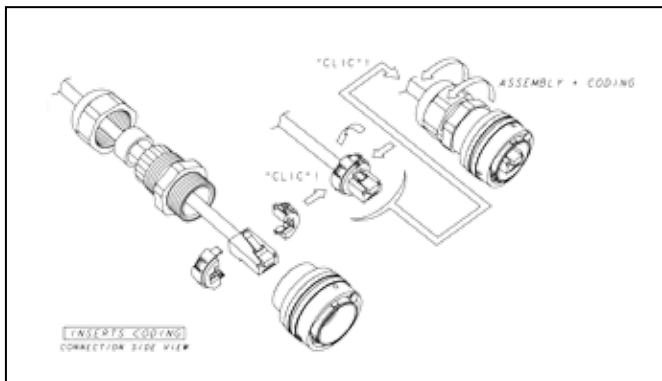

### 4 codings possibilities

(defined by the customer during the assembling).

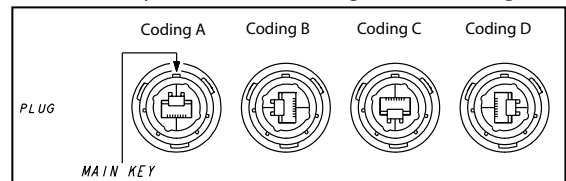

**IMPORTANT NOTE:** to remove the insert, use the

- Insert removal tool for plug

P/N: **RJF ODE**



## Accessories

- Metallic cap

RJFC 2 G

### Connector type

- 6: plug
- 2: square Flange Receptacle
- 7: jam Nut Receptacle

### Shell material & finish

- B: black coating - ROHS compliant
- N: aluminium shell - nickel plating - ROHS compliant
- G: aluminium shell - olive drab cadmium plating

- Panel gasket for square flange « 2 » thickness - 0,6 mm

P/N: **JE 18**

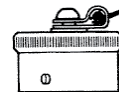

Plug cap

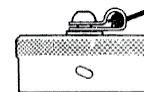

Receptacle cap

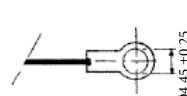

Square Flange type « 2 »



Plug Cap end type « 6 »

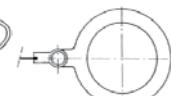

Jam nut receptacle type « 7 »

# RJF6

## CAT6 in line receptacle

In line receptacles allow you to make cable extensions in the field by using them with rugged RJ Field series plugs.

### In line receptacle

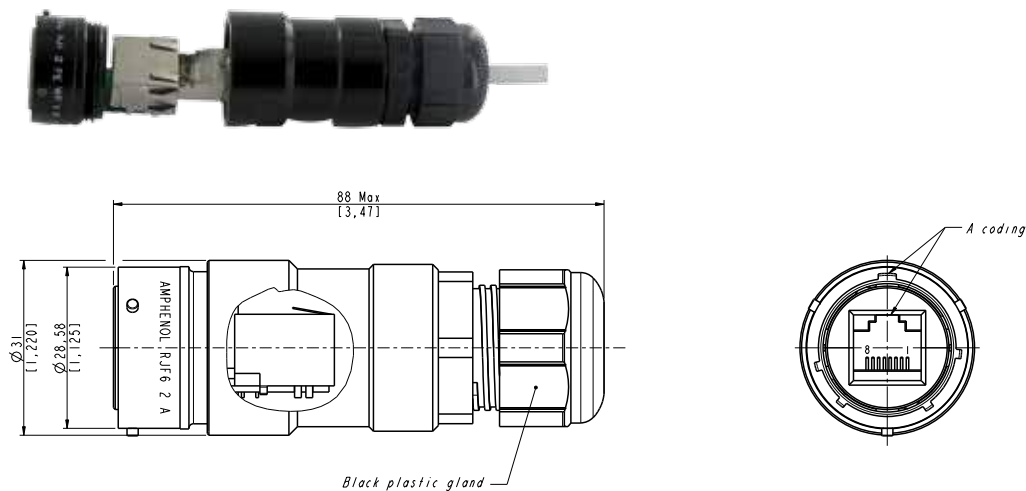

**Codings** - To be specified in the part number: A, B, C, or D.

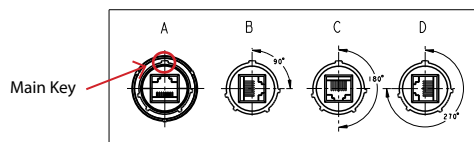

Part number	Plating	Plastic gland	Metallic gland
	Black coating - ROHS compliant	RJF6 2 X PEWF1 B	RJF6 2 X PEMWF 1 B
	Nickel - ROHS compliant	RJF6 2 X PEWF 1 N	RJF6 2 X PEMWF 1 N
	Olive drab cadmium	RJF6 2 X PEWF 1 G	RJF6 2 X PEMWF 1 G

X to be replaced by the letter of the coding position you need (A, B, C, or D)

Cat5e version: page 20 of the Field series catalogue.

- ▶ [Direct access by clicking here](#)
- ▶ Or visit [www.amphenol-socapex.com](http://www.amphenol-socapex.com)

# RJF6

## CAT6 transversally sealed receptacles



In some applications, a transversal sealing for the receptacle is a « must ». This will prevent fluids and dust from going through the receptacle when plug or cap are not mated to the receptacle.

The sealed solution (version "S") has a compound at the rear of the receptacle as shown on the picture. This feature is available both in RJF and RJF TV shells (please consult the relevant data sheet for product details and accessories).

In addition, the sealed RJF TV has been successfully tested in very high vibration corresponding to airplane applications.

- Applications**
- Outdoor equipment
  - Airplanes equipment
  - Tactical radios
  - Shelters
  - Rugged computers
  - Data acquisition and transmission in harsh environments

**Data transmission**  
 10 BaseT, 100 BaseTX and 1000 BaseT up to 250 MHz networks  
 Cat 6 per EIA/TIA 568 and ClassE per ISO 11801

- Main characteristics**
- Same as the RJF series.
  - A complete IP68 sealing of the receptacle (even with no plug or no protective cap mated) is added.
  - Outside dimensions are the same as the standard RJF series.

**IMPORTANT NOTE**  
 Due to the compound, the coding of the connector must be done in the factory  
 Use the codes A, B, C or D in the part number: **see below.**

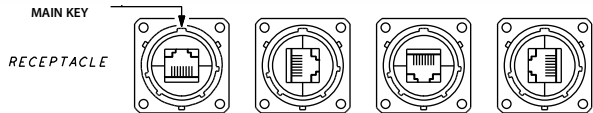

	RJF6	7 S	A	PE	1	G
<b>Shell type</b>						
2 S: sealed square flange receptacle						
7 S: sealed jam nut receptacle						
<b>Coding</b>						
A, B, C, D						
<b>Backshells</b>						
PE: IP68 backshell, plastic gland						
PEM: IP68 backshell, metal gland						
Blank for receptacle without backshell.						
<b>Back termination</b>						
1: female RJ45						
<b>Shell material &amp; finishes</b>						
B: aluminium shell - black coating - ROHS compliant						
N: aluminium shell - nickel plating - ROHS compliant						
G: aluminium shell - olive drab cadmium plating						
BZC: aluminium shell - black zinc cobalt plating						
ZC: aluminium shell - green zinc cobalt plating - ROHS compliant						
<b>NOTA: for N, G, BZC, and ZC plating, the inserts are metallized.</b>						

Examples: - sealed jam nut receptacle, A coding, with female RJ45 back termination, olive drab cadmium plating ⇒ **RJF6 7 S A 1 G**  
 - sealed square flange receptacle, D coding, with IP68 backshell, plastic gland, female RJ45 back termination, black plating ⇒ **RJF6 2 S D PE 1 B**

Cat5e version: page 22 of the Field series catalogue.  
 ▶ [Direct access by clicking here](#)  
 ▶ Or visit [www.amphenol-socapex.com](http://www.amphenol-socapex.com)

# RJF6

## CAT6 hermetic receptacles



In some applications, a transversal hermeticity for the receptacle is a « must ». This will prevent gas from going through the receptacle when plug or cap are not mated to the receptacle.

The hermetic solution (version "H") has a compound at the rear of the receptacle as shown on the picture.

This feature is available both in RJF and RJF TV shells (please consult the relevant data sheet for product details and accessories).

Helium leakage is less than  $1.10^{-6}$  cm<sup>3</sup> per second [0.1 micron cubic ft per hour] at one bar [15 psi] pressure differential.

### Applications

- Outdoor equipment
- Airplanes equipment
- Tactical radios
- Shelters
- Rugged computers
- Data acquisition and transmission in harsh environments

### Data Transmission

10 BaseT, 100 BaseTX and 1000 BaseT up to 250 MHz networks  
Cat 6 per EIA/TIA 568 and ClassE per ISO 11801

### Main characteristics

- Same as the RJF series.
- A complete IP68 sealing of the receptacle (even with no plug or no protective cap mated) is added.
- Outside dimensions are the same as the standard RJF series.

### IMPORTANT NOTE

Due to the compound, the coding of the connector must be done in the factory  
Use the codes A, B, C or D in the part number: **see below**.

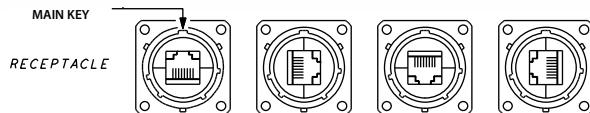

### Part number code

	RJF6	7H	A	1	G
<b>Shell type</b>					
<b>2H:</b> transversally sealed and hermetic square flange receptacle					
<b>7H:</b> transversally sealed and hermetic jam nut receptacle					
<b>Coding</b>					
<b>A,B,C,D</b>					
<b>Back termination</b>					
<b>1:</b> female RJ45					
<b>Shell material &amp; finish</b>					
<b>B:</b> aluminium shell - black coating - <i>ROHS compliant</i>					
<b>N:</b> aluminium shell - nickel plating - <i>ROHS compliant</i>					
<b>G:</b> aluminium shell - olive drab cadmium plating					
			<b>BZC:</b> aluminium shell - black zinc cobalt plating		
			<b>ZC:</b> aluminium shell - green zinc cobalt plating - <i>ROHS compliant</i>		
			<b>NOTA:</b> for N, G, BZC, and ZC plating, the inserts are metallized.		

Examples: - sealed jam nut receptacle, A coding, with female RJ45 Back termination, olive drab cadmium plating ⇒ **RJF6 7HA 1 G**  
- sealed square flange receptacle, A coding, with female RJ45 back termination, black plating ⇒ **RJF6 2HA 1 B**

Cat5e version: page 23 of the Field series catalogue.

- ▶ [Direct access by clicking here](#)
- ▶ Or visit [www.amphenol-socapex.com](http://www.amphenol-socapex.com)

# RJF CAT6 receptacle with self closing cap



This kit includes a receptacle and a self closing cap which protects the RJ Field square flange receptacles (MIL-C-26482 type). This cap offers a protection against dust and water projections. A spring automatically closes the upper part of the cap when either the RJfield plug, USB or IEEE1394 cordset, or USB key are removed from the receptacle.

**Sealing level IP54**  
(Splash and dust Proof)

## RJF6 2 x 1 x SCC

RJ45 version

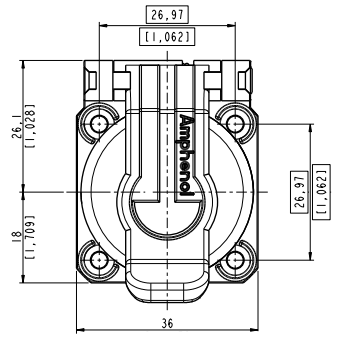
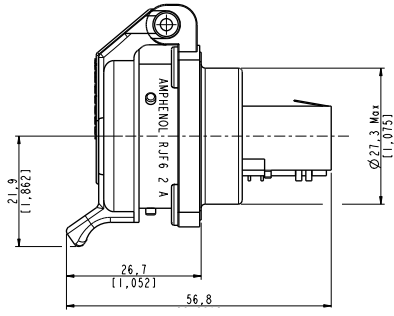

**Codings - To be specified in the part number: A, B, C, or D.**

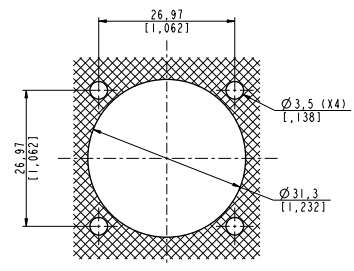
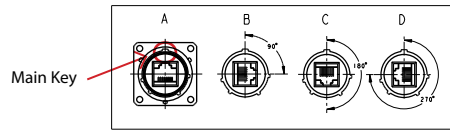

Part number*	Plating	Metallized insert (EMI)	Part number
	Black coating - ROHS compliant	No	RJF6 2 X 1 B SCC
	Nickel - ROHS compliant	Yes	RJF6 2 X 1 N SCC
	Olive drab cadmium	Yes	RJF6 2 X 1 G SCC

\* The part number includes the receptacle + the self closing cap  
X to be replaced by the letter of the coding position you need (A, B, C, or D)

**Remarks:**

- the back termination is female RJ45
- it could be used with our RJF series plug (part number RJF6xx ► see page 9)

■ **Note:** Panel gasket with any of these receptacles: JE18

Cat5e version: page 25 of the Field series catalogue.  
► [Direct access by clicking here](#)  
► Or visit [www.amphenol-socapex.com](http://www.amphenol-socapex.com)

# RJF

## Plug with 360° EMI backshell

RJF series plug with EMI backshells provide a solution with 360° shielding: same protection than the one proposed by standard MIL-DTL-26482 connectors. With those solutions we recommend using our reinforced and double shielded Cat5E, Cat6, and Cat6A cable  
 ▶ see page 27 for Cat6 version

Cat5E version: page 41 of the Field series catalogue ▶ [Direct access by clicking here](#) Or visit [www.amphenol-socapex.com](http://www.amphenol-socapex.com)  
 Cat6A version: page 43 of the Field series catalogue ▶ [Direct access by clicking here](#)

### Plug - Straight backshell

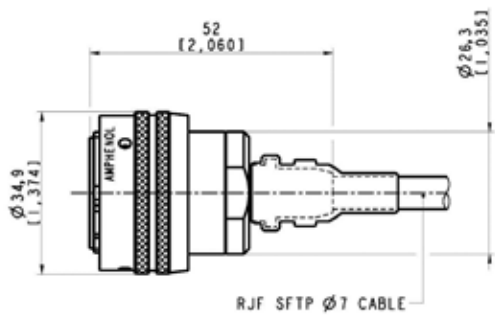

Part number	Plating	Part number
	Nickel - ROHS compliant	Kit30394NI
	Olive drab cadmium	Kit30394

Kit30394 & Kit30394NI include:





# RJF

Special plug for big insulation wire up to 1.6 mm [0.062 in]



Rugged plug dedicated to cable with insulation wire from 1,1 to 1,6 mm [from 0.043 in to 0.062 in]

**Remark:**

- Solution compatible with any RJF6 receptacle
- For cables which are not compatible with standard RJ45 plug.

**Applications**

- Robotics
- Industrial process control
- CNC machines
- Special machines
- Oil & Gas
- Motion control
- Data acquisition and transmission in harsh environment
- Tele-maintenance

**Data Transmission**

10 BaseT, 100 BaseTX and 1000 BaseT up to 250 MHz networks  
Cat 6 per EIA/TIA 568 and ClassE per ISO 11801

**Main characteristics**

- **Bayonet coupling** ("Audible & Visual" coupling signal )
- **Robust metallic shells based on MIL-DTL-26482 H - Shell size 18**
- RJ45 cordset retention in the plug: 100 N in the axis
- Mating cycles: 500 min
- Sealed against fluids and dust (IP68)
- Shock, vibration and traction resistant
- Mechanical coding / polarization (4 positions)
- Compatible with cable diameter from 6 mm [0.216 in] to 13 mm [0.512 in]. For smaller diameters, please consult us.

**Environmental protection**

- Sealing: IP68
- Salt Spray: 48 h with nickel plating  
> 96 h with black coating  
> 500 h with oliv drab cadmium
- Fire retardant/Low smoke: UL94 V0 and NF F 16 101 & 16 102
- Vibrations: 10 – 500 Hz, 10 g, 3 axes: no discontinuity >10 nano s.
- Shocks: IK06 ► weight of 250 g drop from 40 cm [15.75 in] onto connectors (mated pair)
- Humidity: 21 days, 43°C, 98% humidity
- Temperature range: - 40°C / +85°C

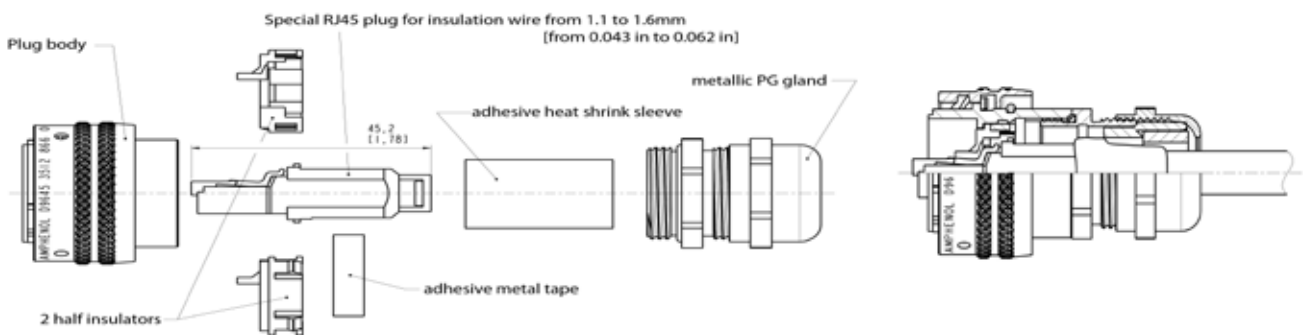

Part number	Plating	Part number
	Nickel - ROHS compliant	Kit39992NI
	Olive drab cadmium	Kit39992G

# RJF TV6

CAT6 Ethernet connection system for harsh environment



RJFTV Cat6 allows you to use an Ethernet Class E / Cat. 6 connection for 10 BaseT, 100 BaseTx or 1000 BaseT up to 250 MHz networks in harsh environments. With the patented RJStop system you can use a standard RJ45 cordset in a **metallic** plug which will protect it from shocks, dust and fluids.  
**No hazardous on-field cabling and grounding!**

### Applications

- Data acquisition and transmission in harsh environment
- Railways
- Radars
- Shelters
- Battlefield communication
- Systems
- Navy

### Data Transmission

10 BaseT, 100 BaseTX and 1000 BaseT up to 250 MHz networks  
Cat 6 per EIA/TIA 568 and ClassE per ISO 11801

Cat5e version: page 26 of the Field series catalogue.

- ▶ [Direct access by clicking here](#)
- ▶ Or visit [www.amphenol-socapex.com](http://www.amphenol-socapex.com)

### Main characteristics

- Sealed against fluids and dusts (IP68)
- Shock, vibration and traction resistant
- No cabling operation in field and no tools required
- Mechanical coding / Polarization (4 positions)
- Improved EMI protection
- **Tri Start Thread coupling mechanism (MIL-DTL-38999 series III type) with anti-decoupling device - Shell size 19**
- **Robust metallic shells**
- RJ45 cordset retention in the plug: 100 N in the axis
- Mating cycles: 500 min
- Compatible with cable diameter from 6 mm [0.236 in] to 13 mm [0.512 in]. For smaller diameters please consult us.

### Environmental protection

- Sealing: IP68
- Salt spray: 48h with aluminium shell - Nickel, & black zinc cobalt plating  
> 500h with aluminium shell - Olive drab cadmium plating  
500 h with marine bronze shell
- Fire retardant/Low smoke : UL94 V0 and NF F 16 101 & 16 102
- Vibrations : 10 - 500 Hz, 10 g, 3 axes: no discontinuity > 10 nano s.
- Compounded versions tested per NAS 1599 (5-3000 Hz, 20g, 12h)
- Shocks: IK06 ▶ weight of 250 g drop from 40 cm [15.75 in] onto connectors (mated pair)
- Humidity: 21 days, 43°C, 98% humidity
- Temperature range: -40°C / +85°C

### Part number code: receptacles.

	RJF TV6	2	A	PEM	1	G
<b>Shell type</b>						
2: square flange receptacle						
7: jam nut receptacle						
<i>Nota: also available a transversally sealed receptacle (unmated) ▶ See page 22</i>						
<b>Coding</b>						
A, B, C, or D						
<b>Backshells</b>						
PE: IP68 backshell, plastic gland						
PEM: IP68 backshell, metal gland						
Blank for receptacles without backshell						
<b>Back terminations</b>						
1: female RJ45						
<b>Shells material &amp; Finish (inserts are metallized)</b>						
N: aluminium shell - nickel plating - ROHS compliant						BZC: aluminium shell - black zinc cobalt plating
G: aluminium shell - olive drab cadmium plating						ZC: aluminium shell - green zinc cobalt plating - ROHS compliant
BZ: marine bronze shell - ROHS compliant						ZN: aluminium shell - black zinc nickel plating - ROHS compliant

Example: jam nut receptacle, coding A, female RJ45 back termination, olive drab cadmium plating ⇒ RJF TV6 7 A 1 G

### Part number code: plugs ▶ see page 20.

	RJF TV	6	G
<b>Shell type</b>			
6: plug with plastic gland			
6M: plug with metal gland			
<b>Shells material &amp; Finish (inserts are metallized)</b>			
N: aluminium shell - nickel plating - ROHS compliant			BZC: aluminium shell - black zinc cobalt plating
G: aluminium shell - olive drab cadmium plating			ZC: aluminium shell - green zinc cobalt plating - ROHS compliant
BZ: marine bronze shell - ROHS compliant			ZN: aluminium shell - black zinc nickel plating - ROHS compliant

Example: plug with plastic gland, olive drab cadmium plating ⇒ RJF TV 6G

**NOTA:** also available a plug with 360° EMI backshell, and a plug for big insulation wire up to 1.6mm ▶ see pages 24 & 25.

## Receptacles

### ■ Square flange receptacle - 4 mounting holes: shell type 2

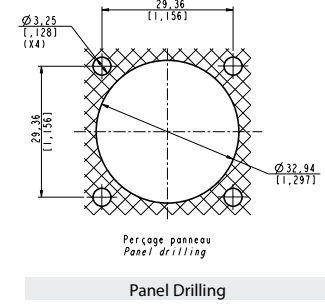
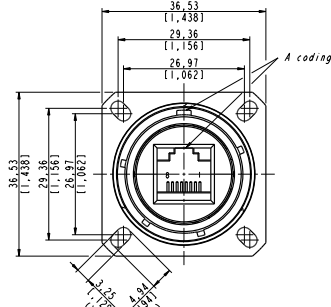
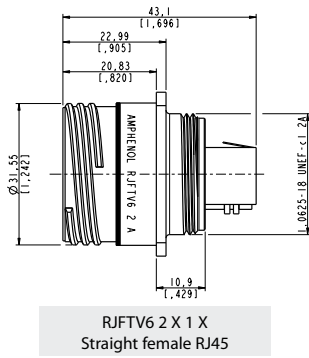

### ■ Jam nut receptacle - Hexagonal nut mounting: shell type 7

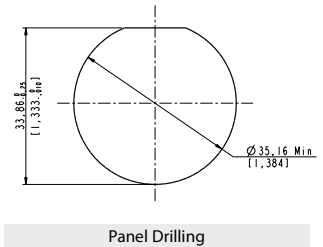
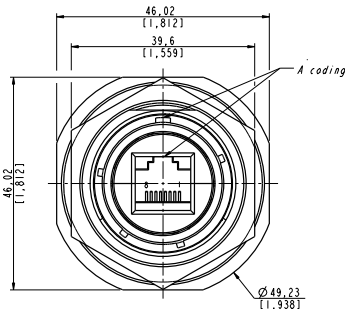
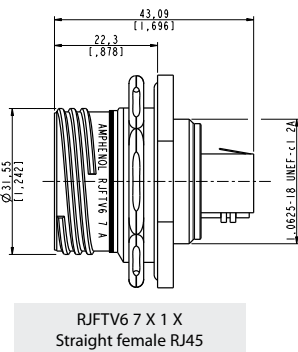

### ■ Receptacles with IP68 backshell: Shell type 2PE and 7PE with plastic or metal gland

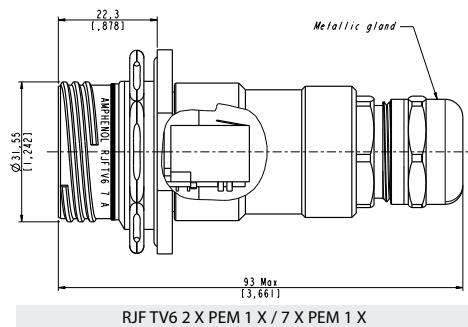
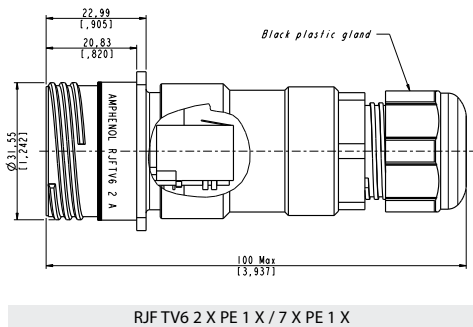

## Codings - To be specified in the part number: A, B, C, or D.

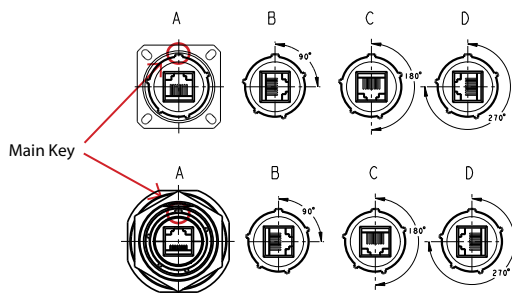

## Back terminations

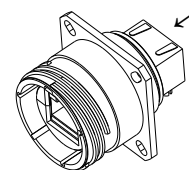

Type 1  
Female RJ45

## Plug

- Shell type 6 with plastic or metal gland

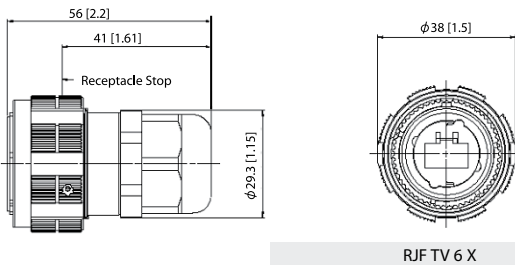

**NOTA:** also available a plug with 360° EMI backshell, and a plug for big insulation wire up to 1.6mm  
▶ see pages 24 & 25.

## Assembly instructions

### Insert codings

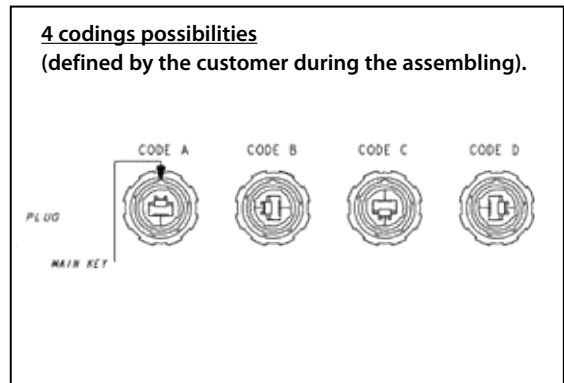
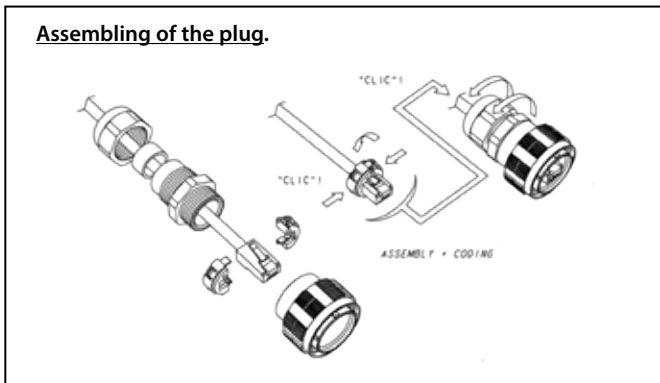

**IMPORTANT NOTE:** to remove the insert, use the

- Insert removal tool for plug

P/N: **RJF ODE**



### Accessories

- Metallic Caps

	RJFTVC	2	G
<b>Connector type</b>			
6: plug			
2: square flange receptacle			
7: jam nut receptacle			
<b>Shell material &amp; finish</b>			
N: aluminium shell - nickel plating - ROHS compliant			
G: aluminium shell - olive drab cadmium plating			
BZ: marine bronze shell - ROHS compliant			
ZC: aluminium shell - green zinc cobalt plating - ROHS compliant			
ZN: aluminium shell - black zinc nickel plating - ROHS compliant			

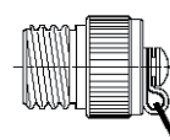

Plug Cap

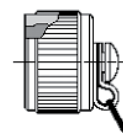

Receptacle Cap

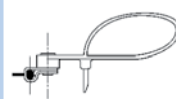

Plug Cap end

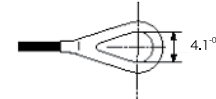

Square flange receptacle cap end



Jam Nut receptacle cap end

- Panel gasket for square flange receptacle

Thickness: 0,8 mm [.031]:

P/n: **JE19**



# RJF TV6

## CAT6 through bulkhead receptacles

Our RJF TV Cat6 through bulkhead receptacles can be connected on each side with rugged RJF TV plugs. This system allows mechanical protection and a sealing (IP68 when mated) inside and outside the equipment, and keeps the flexibility offered by panel mount and plug connectors.

### Square flange receptacle

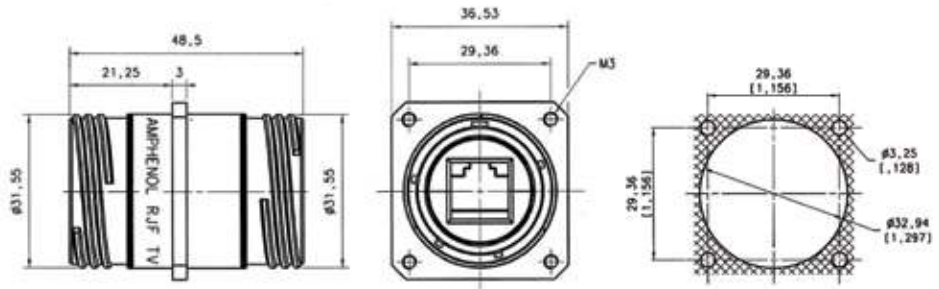

Part number	Plating	Metallized insert	For coding A
	Nickel - ROHS compliant	No	RJF TV6 B 2 N ISO BRUT *
	Nickel - ROHS compliant	Yes	RJF TV6 B 2 N ISO NI *
	Olive drab cadmium	No	RJF TV6 B 2 G ISO BRUT *
	Olive drab cadmium	Yes	RJF TV6 B 2 G ISO NI *

\* ISO BRUT = non conductive insert  
ISO NI = conductive insert

**IMPORTANT NOTE**  
Possibility of other codings - Please consult us

### Jam nut receptacle

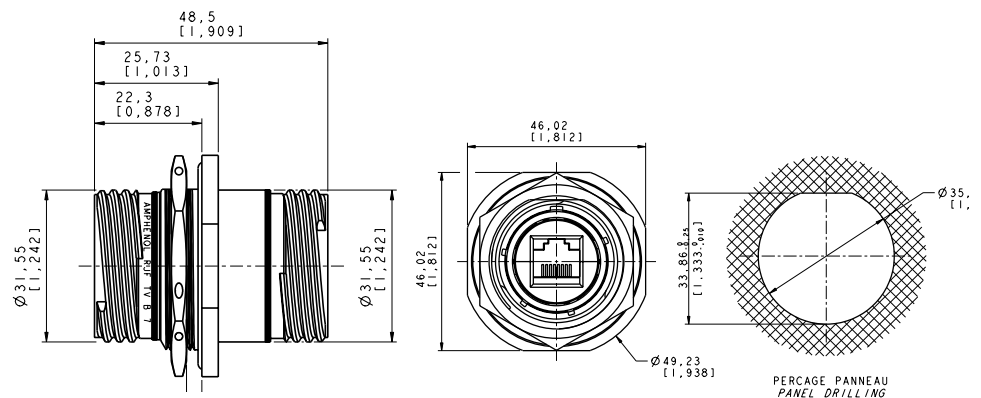

Part number	Plating	Metallized insert	Part number
	Nickel - ROHS compliant	No	RJF TV6 B 7 N ISO BRUT *
	Nickel - ROHS compliant	Yes	RJF TV6 B 7 N ISO NI *
	Olive drab cadmium	No	RJF TV6 B 7 G ISO BRUT *
	Olive drab cadmium	Yes	RJF TV6 B 7 G ISO NI *

\* ISO BRUT = non conductive insert  
ISO NI = conductive insert

Cat5e version: page 32 of the Field series catalogue.

► [Direct access by clicking here](#)

► Or visit [www.amphenol-socapex.com](http://www.amphenol-socapex.com)

# RJF TV6

CAT6 transversally sealed receptacles



In some applications, a transversal sealing for the receptacle is a « must ». This will prevent fluids and dust from going through the receptacle when plug or cap are not mated to the receptacle.

The sealed solution (version "S") has a compound at the rear of the receptacle as shown on the picture. This feature is available both in RJF and RJF TV shells (please consult the relevant data sheet for product details and accessories).

In addition, the Sealed RJF TV has been successfully tested in very high vibration corresponding to airplane applications.

### Applications

- Outdoor equipment
- Airplanes equipment
- Tactical radios
- Shelters
- Rugged computers
- Data acquisition and transmission in harsh environments

### Data transmission

10 BaseT, 100 BaseTX and 1000 BaseT up to 250 MHz networks  
Cat 6 per EIA/TIA 568 and ClassE per ISO 11801

### Main characteristics

- Same as the RJF TV series.
- A complete IP68 sealing of the receptacle (even with no plug or no protective cap mated) is added.
- Outside dimensions are the same as the standard RJF and RJF TV series.
- Vibrations: the compounded versions of the RJF TV have been tested in vibration following the NAS 1599 Aeronautic specification (Ambient temperature):  
5 - 3000 Hz, 20g, 2,5 mm [.1 inch] double amplitude, 3 axes, 12 hours  
Note: this specification exceeds MIL-C-26500 requirements.

### IMPORTANT NOTE

Due to the compound, the coding of the connector must be done in the factory : use the codes A, B, C or D in the part number: **see below**.



### Part number code

	RJF TV6	7S	A	1	G
<b>Shell type</b>					
<b>2S:</b> sealed square flange receptacle					
<b>7S:</b> sealed jam nut receptacle					
<b>Coding</b>					
<b>A,B,C,D</b>					
<b>Back terminations (for receptacles only)</b>					
<b>1:</b> female RJ45					
<b>Shell material &amp; finish (inserts are metallized)</b>					
<b>N:</b> aluminium shell - nickel plating - ROHS compliant					
<b>G:</b> aluminium shell - olive drab cadmium plating					
<b>BZ:</b> marine bronze shell - ROHS compliant					
			<b>BZC:</b> aluminium shell - black zinc cobalt plating		
			<b>ZC:</b> aluminium shell - green zinc cobalt plating - ROHS compliant		
			<b>ZN:</b> aluminium shell - black zinc nickel plating - ROHS compliant		

Examples: - sealed jam nut receptacle, A coding, with female RJ45 back termination, olive drab cadmium plating ⇒ **RJF TV6 7SA 1 G**  
- sealed square flange receptacle, A coding, with female RJ45 back termination, nickel plating ⇒ **RJF TV6 2SA 1 N**

Cat5e version: page 36 of the Field series catalogue.

- ▶ [Direct access by clicking here](#)
- ▶ Or visit [www.amphenol-socapex.com](http://www.amphenol-socapex.com)

# RJF TV6

## CAT6 hermetic receptacles



In some applications, a transversal hermeticity for the receptacle is a « must ». This will prevent gas from going through the receptacle when plug or cap are not mated to the receptacle.

The hermetic solution (version "H") has a compound at the rear of the receptacle as shown on the picture.

This feature is available both in RJF and RJF TV shells (please consult the relevant data sheet for product details and accessories).

Helium leakage is less than  $1.10^{-6}$  cm<sup>3</sup> per second [0.1 micron cubic ft per hour] at one bar [15 psi] pressure differential.

### Applications

- Outdoor equipment
- Airplanes equipment
- Tactical radios
- Shelters
- Rugged computers
- Data acquisition and transmission in harsh environments

### Data Transmission

10 BaseT, 100 BaseTX and 1000 BaseT up to 250 MHz networks  
Cat 6 per EIA/TIA 568 and ClassE per ISO 11801

### Main characteristics

- Same as the RJF TV series.
- A complete IP68 sealing of the receptacle (even with no plug or no protective cap mated) is added.
- Outside dimensions are the same as the standard RJF TV series.
- Vibrations: the compounded versions of the RJF TV have been tested in vibration following the NAS 1599 Aeronautic specification (Ambient temperature):  
5 - 3000 Hz, 20g, 2,5 mm [.1 inch] double amplitude, 3 axes, 12 hours  
Note: this specification exceeds MIL-C-26500 requirements.

### IMPORTANT NOTE

Due to the compound, the coding of the connector must be done in the factory: use the codes A, B, C or D in the part number: **see below**.



### Part number code

	RJF TV6	7H	A	1	G
<b>Shell type</b>					
<b>2H:</b> transversally sealed and hermetic square flange receptacle					
<b>7H:</b> transversally sealed and hermetic jam nut receptacle					
<b>Coding</b>					
<b>A,B,C,D</b>					
<b>Back terminations (for receptacles only)</b>					
<b>1:</b> female RJ45					
<b>Shell material &amp; finish (inserts are metallized)</b>					
<b>N:</b> aluminium shell - nickel plating - ROHS compliant					
<b>G:</b> aluminium shell - olive drab cadmium plating					
<b>BZ:</b> marine bronze shell - ROHS compliant					
			<b>BZC:</b> aluminium shell - black zinc cobalt plating		
			<b>ZC:</b> aluminium shell - green zinc cobalt plating - ROHS compliant		
			<b>ZN:</b> aluminium shell - black zinc nickel plating - ROHS compliant		

Examples: - sealed jam nut receptacle, A coding, with female RJ45 back termination, olive drab cadmium plating ⇒ **RJF TV6 7HA 1 G**  
- sealed square flange receptacle, A coding, with female RJ45 back termination, nickel plating ⇒ **RJF TV6 2HA 1 N**

Cat5e version: page 37 of the Field series catalogue.

- ▶ [Direct access by clicking here](#)
- ▶ Or visit [www.amphenol-socapex.com](http://www.amphenol-socapex.com)

# RJF TV

## Plug with 360° EMI backshells

RJF TV series plugs with EMI backshells provide a solution with 360° shielding: same protection than the one proposed by standard MIL-DTL-38999 series III connectors.

With those solutions we recommend using our reinforced and double shielded Cat5E, Cat6, and Cat6A cable.

► see page 27 for Cat6 version

Cat5E version: page 41 of the Field series catalogue ► [Direct access by clicking here](#)

Or visit [www.amphenol-socapex.com](http://www.amphenol-socapex.com)

Cat6A version: page 43 of the Field series catalogue ► [Direct access by clicking here](#)

### Plug - Straight backshell



Part number	Plating	P/N
	Nickel - ROHS compliant	Kit38081NI
	Olive drab cadmium	Kit38081
	Green zinc cobalt - ROHS compliant	Kit38081ZC
	Black zinc cobalt - ROHS compliant	Kit38081BZC

### Plug - Right angle backshell

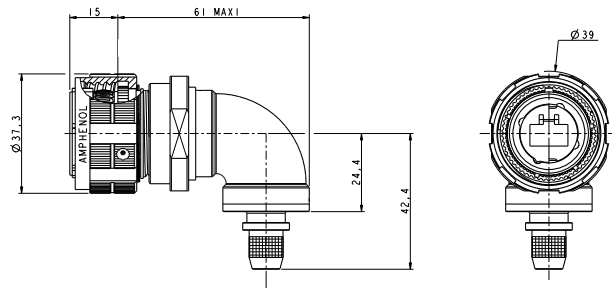

Part number	Plating	P/N
	Nickel - ROHS compliant	Kit40792NI
	Olive drab cadmium	Kit40792
	Green zinc cobalt - ROHS compliant	Kit40792ZC
	Black zinc cobalt - ROHS compliant	Kit40792BZC

Kit38081 and Kit40792 include:



Plug body

Inserts

Backshell body

Band

Heat shrink sleeve

### IMPORTANT NOTE

With these plugs, the standard RJ45 plug is not provided. Customer will have to crimp a standard RJ45 on the cable by himself.

**Remark:** we advise using our double shielded, reinforced Cat6 cables (see page 27) with these RJF TV series EMI connectors. If customer wants to use his own cable, please check with us regarding compatibility with our backshells: [contact@rjfield.com](mailto:contact@rjfield.com). We also provide assembled cordsets (**see example below**). For this type of solution please provide the configuration needed: length, description of second end...

Example of assembled cordset:

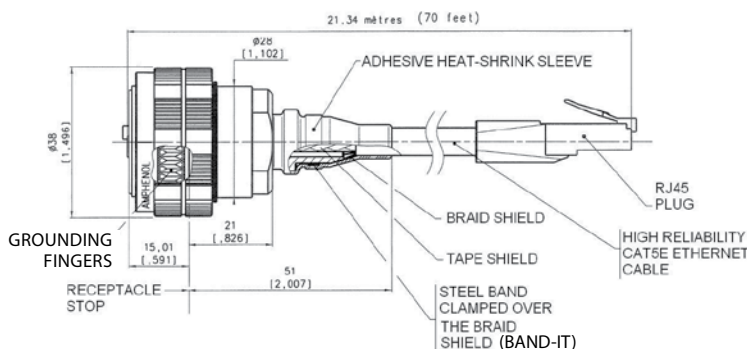



# RJF TV

Special plug for big insulation wire up to 1.6 mm



Special RJF TV plug dedicated to Ethernet cable with insulation wire from 1,1 to 1,6 mm.

**Remark:**

- compatible with any RJF TV6 receptacle
- for cables which are not compatible with standard RJ45 plug

**Applications**

- Robotics
- Industrial process control
- CNC machines
- Special machines
- Oil & Gas
- Motion control
- Data acquisition and transmission in harsh environment
- Tele-maintenance

**Data Transmission**

10 BaseT, 100 BaseTX and 1000 BaseT up to 250 MHz networks  
 Cat 6 per EIA/TIA 568 and ClassE per ISO 11801

**Main characteristics**

- Sealed against fluids and dusts (IP68)
- Shock, vibration and traction resistant
- No cabling operation in field and no tools required
- Mechanical coding / Polarization (4 positions)
- Improved EMI protection
- **Tri Start Thread coupling mechanism (MIL-DTL-38999 series III type) with anti-decoupling device - Shell size 19**
- **Robust metallic shells**
- RJ45 cordset retention in the plug: 100 N in the axis
- Mating cycles: 500 min
- Compatible with cable diameter from 6 mm [0.236 in] to 13 mm [0.512 in], for smaller diameters please consult us

**Environmental protection**

- Sealing: IP68
- Salt spray: 48 h with nickel plating  
 > 96 h with black coating  
 > 500 h with olive drab cadmium
- Fire retardant/Low smoke: UL94 V0 and NF F 16 101 & 16 102
- Vibrations: 10 – 500 Hz, 10 g, 3 axes: no discontinuity > 10 nano s.
- Shocks: IK06 ▶ weight of 250 g drop from 40 cm [15.75 in] onto connectors (mated pair)
- Humidity: 21 days, 43°C, 98% humidity
- Temperature range: - 40°C / +85°C

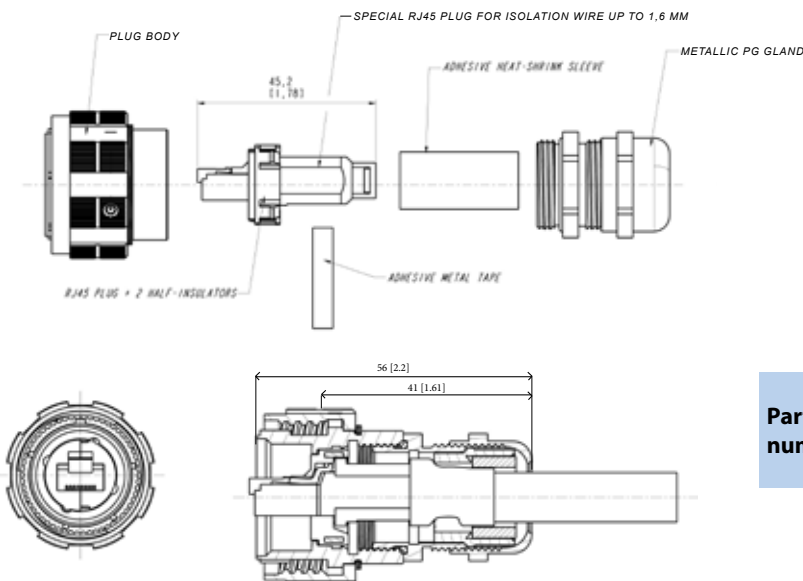

Part number	Plating	P/N
	Nickel - ROHS compliant	35660
Olive drab cadmium	35660G	

# RJFTV

## Self closing cap (SCC series) for RJFTV6 receptacles

This self closing cap automatically protects the RJF TV square flange receptacle (MIL-DTL-38999 type), protecting your system from dust and water projection. A spring automatically closes the upper part of the cap when the RJF TV plug is removed from the receptacle.

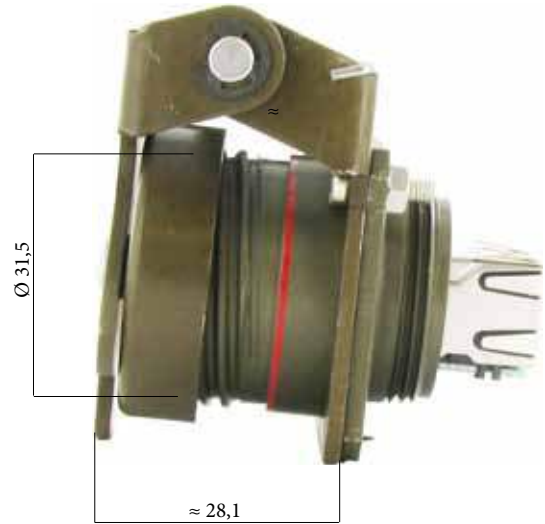
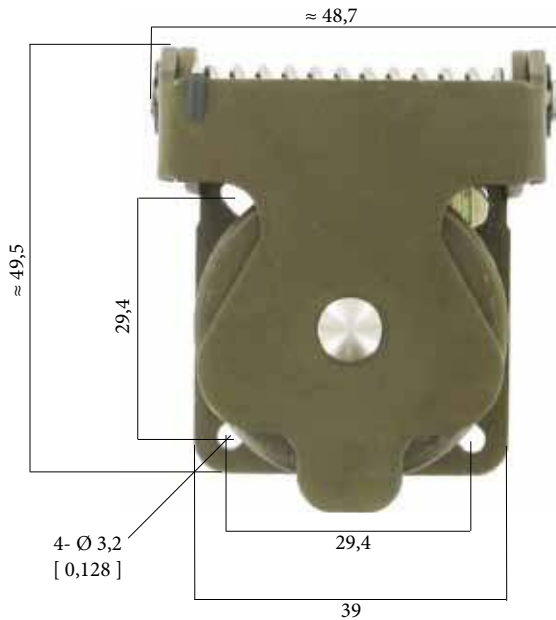

### IMPORTANT NOTE

- Metal self closing cap are sold separately (without receptacle).
- This self closing cap must be used with reinforced RJFTV plugs.

Sealing level IP67



Part number	Plating	Part number
	Black coating - <i>ROHS compliant</i>	RJF TV SCC B
	Nickel - <i>ROHS compliant</i>	RJF TV SCC N
	Olive drab cadmium	RJFTV SCC G

**Remark:** compatible with RJFTV6 square flange receptacle type RJFTV6 2xxx only (see page 18).

# CAT 6 CABLE

High reliability Cat 6 Ethernet cable & cordsets



### General construction

A 4 pairs, 26 AWG, 100 Ohm SFTP round patch cable, designed to the ISO 11801 Category 6 requirements. The cable contains 4 twisted pairs individually shielded, cabled, double shielded with kevlar reinforcement strands, jacketed in black UV resistant Polyurethane HFFR. Designed for fixed or portable applications in harsh environments.

### HFFR: Halogen Free Flame Retardant

Jacket compound specification:

- Halogen free flame retardant polyether-based polyurethane
- Excellent hydrolysis resistance
- High microbial resistance
- Glossy finish
- UV resistant
- High flexibility

### Applications

- Robotics
- Motion control
- Railways
- CNC machines
- Battlefield communication
- Industrial process control

### Electrical characteristics (at 20°C - 68°F)

<b>DC Resistance</b>	290 Ohm/Km
<b>Impedance (100 MHz)</b>	100 +/- 5 Ohm

Frequency	Insertion loss (dB/100m)	N.E.X.T. (Near-End Crosstalk Loss)
1 MHz	3.1 dB	75.3 dB min.
4 MHz	5.8 dB	66.3 dB min.
8 MHz	8.0 dB	61.8 dB min.
10 MHz	9.0 dB	60.3 dB min.
16 MHz	11.4 dB	57.2 dB min.
20 MHz	12.8 dB	55.8 dB min.
25 MHz	14.1 dB	54.3 dB min.
31.25 MHz	16.1 dB	52.8 dB min.
62.5 MHz	23.2 dB	48.4 dB min.
100 MHz	29.9 dB	45.3 dB min.
200 MHz	43.7 dB	40.8 dB min.
250 MHz	49.7 dB	39.3 dB min.

(According to IEC 61156-6)

<b>Capacitance (1 kHz)</b>	50nF/km nom.
<b>Capacitance unbalance</b>	1600 pF/km max.
<b>Insulation resistance</b>	5 GOhm/km
<b>Voltage rating (peak)</b>	230 V
<b>Dielectric strength</b>	VAC/1 min - 700 V/Min
<b>Propagation delay</b>	4.6 ns/m
<b>Skew</b>	45 ns/100m
<b>Resistance unbalance</b>	2%
<b>Return loss (250 MHz)</b>	15.6dB
<b>Velocity of propagation</b>	72% nom.

### Reel of cable (without RJ45 plug on ends)

Length (m / ft)	Part number
100 m / ~328 ft	191-031179-00
300 m / ~984 ft	191-031179-01

### Physical characteristics

Datas for the cable alone only (without RJ45 plug)

<b>Conductors</b>	26 AWG (0,14 mm <sup>2</sup> ) tinned copper
<b>Insulation</b>	Polyethylene Nom. Dia. 0,039" (1mm)
<b>Assembly</b>	Pairs cabled with Kevlar strength members and separation tape wrapped
<b>Shields</b>	Inner: aluminium mylar 100% coverage Outer: tinned copper braid 80% coverage
<b>Jacket</b>	Black, special PUR compound
<b>Weight</b>	36.9 lbs / mft (55 kg/km)
<b>Outside diam.</b>	0.272" (6.9 mm) nom.
<b>Min bend radius (During installation)</b>	72mm (10x O. D.)
<b>Min bend radius (During operation)</b>	36mm (5 x O.D.)
<b>Min flexes to failure</b>	Passes IEC 61156-6 requirements
<b>Temperature</b>	-40°C (-40°F) / + 85°C (185°F)

### Cordsets with a RJ45 plug overmolded on each end

Length (m/ft)	Part number
0,75 m / 2,46 ft	RJF SFTP 6 0075
1,00 m / 3,28 ft	RJF SFTP 6 0100
1,50 m / 4,92 ft	RJF SFTP 6 0150
2,00 m / 6,56 ft	RJF SFTP 6 0200
2,50 m / 8,20 ft	RJF SFTP 6 0250
3,00 m / 9,84 ft	RJF SFTP 6 0300
3,50 m / 11,48 ft	RJF SFTP 6 0350
4,00 m / 13,12 ft	RJF SFTP 6 0400
4,50 m / 14,76 ft	RJF SFTP 6 0450
5,00 m / 16,40 ft	RJF SFTP 6 0500
6,00 m / 19,68 ft	RJF SFTP 6 0600
7,00 m / 22,96ft	RJF SFTP 6 0700
8,00 m / 26,24 ft	RJF SFTP 6 0800
9,00 m / 29,52 ft	RJF SFTP 6 0900
10,00 m / 32,80 ft	RJF SFTP 6 1000
15,00 m / 49,20 ft	RJF SFTP 6 1500
20,00 m / 65,60 ft	RJF SFTP 6 2000
25,00 m / 82,00 ft	RJF SFTP 6 2500
30,00 m / 98,40 ft	RJF SFTP 6 3000
35,00 m / 114,80 ft	RJF SFTP 6 3500
40,00 m / 131,20 ft	RJF SFTP 6 4000
45,00 m / 147,60 ft	RJF SFTP 6 4500
50,00 m / 164,00 ft	RJF SFTP 6 5000
60,00 m / 196,80 ft	RJF SFTP 6 6000

# RJF TVX6

CAT6 RJ45 explosion proof solution for **Zone 2**



Amphenol Atex Field Bus range is designed for device group II category 3G. According to EN60079-15 it may be operated within zone 2 and class I, Division 2, as low power non sparking connectors.



RJFTVX6 allows you to use an Ethernet Class E / Cat.6 connection for 10 BaseT, 100 BaseTx or 1000 BaseT networks up to 250 MHz in ATEX zone 2 environments. With the patented RJStop system you can use a standard RJ45 cordset in a metallic plug which will protect it from shocks, dust and fluids. RJFTVX6 features the same main characteristics than RJFTV6 series (see page 18).

## Main characteristics

■ Ex marking	II3G ExnAII6 X
■ Operating temperature range	-40°C / +60°C
■ Voltage	60 Veff max
■ Power	20 W max
■ Outside cable diameter	6mm to 12mm
■ Sealing	IP68
■ Data transmission	10 BaseT, 100 BaseTX & 1000 BaseT up to 250 MHz networks. Cat. 6 per EIA/TIA 568 & Class E per ISO 11801

## Part number code: receptacles.

Series	RJF TVX6	7S	A	1	N
Shell Type	2S: Square flange receptacle 7S: Jam nut receptacle				
Coding	"A" (Standard) or "B", "C", "D"				
Back termination	1: Female RJ45				
Shell Material and Finish:	N: Nickel G: Olive drab cadmium				

Example: jam nut receptacle, A coding, with female RJ45 back termination, olive drab cadmium plating ⇒ **RJF TVX6 7SA 1 G**

## Part number code: plug.

Series	RJF TVX	6M	N
Shell Type	6M: Plug		
Shell Material and Finish:	N: Nickel G: Olive drab cadmium		

Example: plug, olive drab cadmium plating ⇒ **RJF TVX 6MG**

Cat5e version: page 132 of the Field series catalogue.

► [Direct access by clicking here](#)

► Or visit [www.amphenol-socapex.com](http://www.amphenol-socapex.com)



## Receptacles

### Square flange receptacle - 4 mounting holes: shell type 2

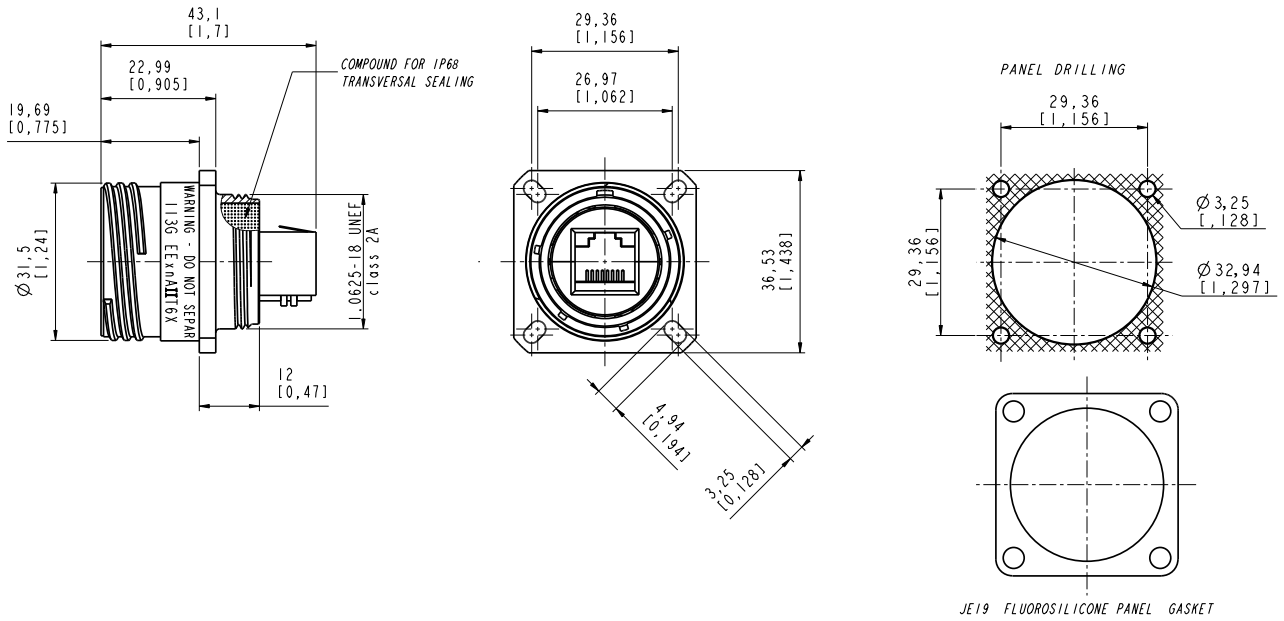

### Jam nut receptacle

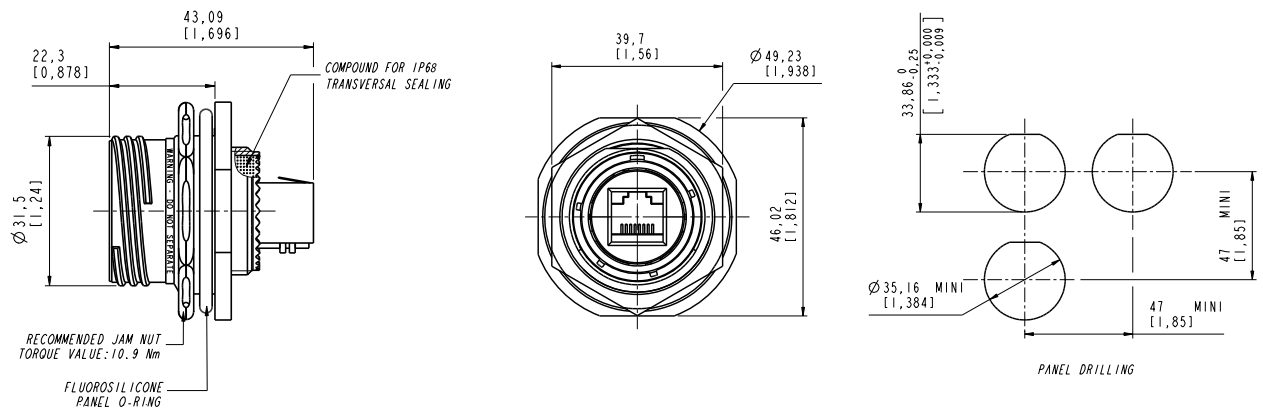

### Codings - To be specified in the part number: A, B, C, or D.

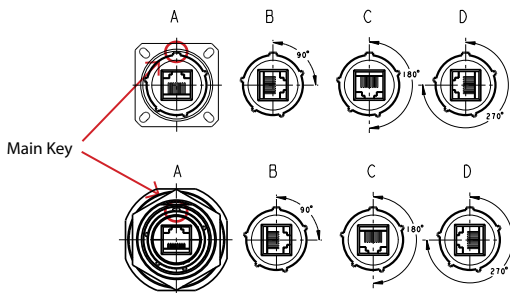

### Back termination

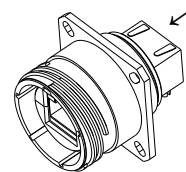

Type 1  
Female RJ45

## Plug

- Shell type 6 with metal gland

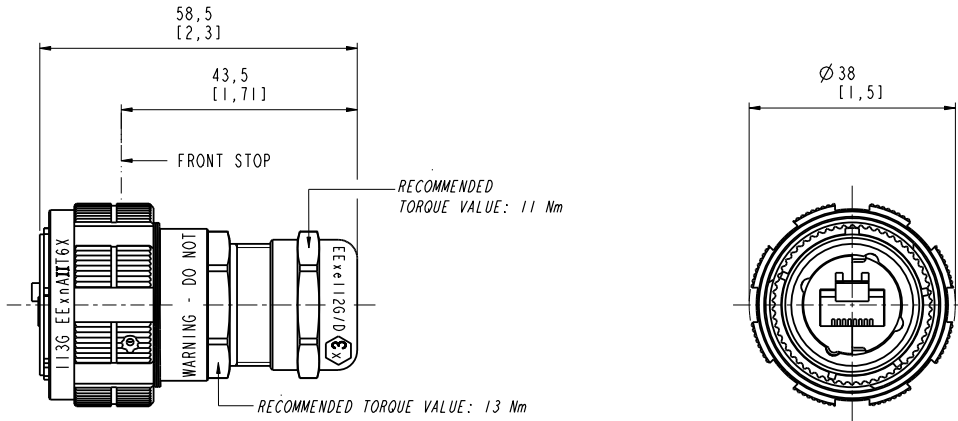

## Assembly instructions

### Insert codings

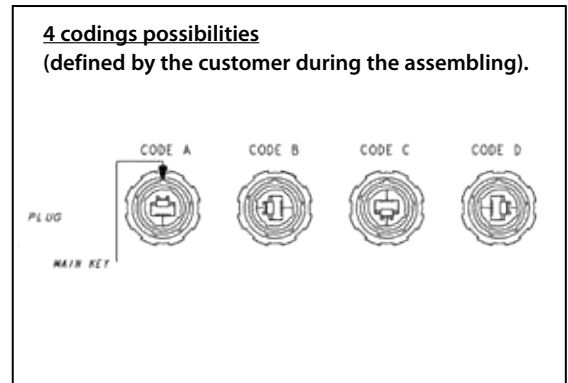
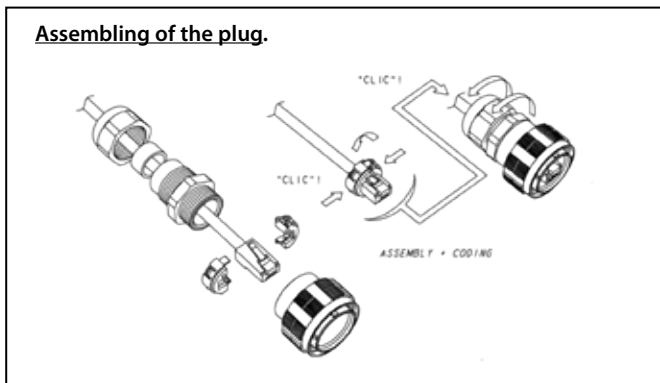

**IMPORTANT NOTE:** to remove the insert, use the

- Insert removal tool for plug

P/N: RJF ODE



## Accessories

- Metallic Caps

RJFTVC 2 G

### Connector type

- 6: plug
- 2: square flange receptacle
- 7: jam nut receptacle

### Shell material & finish

- N: aluminium shell - nickel plating - ROHS compliant
- G: aluminium shell - olive drab cadmium plating

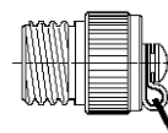

Plug Cap

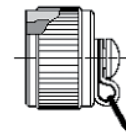

Receptacle Cap

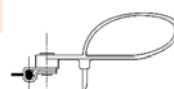

Plug Cap end

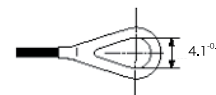

Square flange receptacle cap end



Jam Nut receptacle cap end



# Amphenol in the world

## Amphenol Socapex

948, promenade de l'Arve BP29  
74311 Thyez Cedex - France  
Phone: +33 (0)4 50 89 28 00  
[contact@amphenol-socapex.fr](mailto:contact@amphenol-socapex.fr)  
[www.amphenol-socapex.com](http://www.amphenol-socapex.com)

 [www.twitter.com/AmphenolSocapex](http://www.twitter.com/AmphenolSocapex)  
 [www.linkedin.com/company/amphenol-socapex](http://www.linkedin.com/company/amphenol-socapex)

## Other Amphenol Sales contacts in Europe

### Amphenol Air LB

2 rue Clément Ader, ZAC de Wé  
08110 Carignan - France  
Phone: +33 (0)1 49 05 30 00

### Amphenol AIR LB GmbH

Am Kleinbahnhof 4  
66740 Saarlouis - Germany  
Phone: +49 6831 981 00

### Amphenol TUCHEL ELECTRONICS

August-Haeusser-Str. 10  
D-74080 Heilbronn - Germany  
Phone: +49 7131 929 00

### Amphenol BENELUX

Zadkinestraat 26  
Almere, 1328 NN - The Netherlands  
Phone: +31 651 296835

### Amphenol LIMITED

Thanet Way, Whitstable  
Kent, CT53JF - United Kingdom  
Phone: +44 1227 773 200

### Amphenol ITALY

Via Barbaiana n.5  
20020 Lainate - Milano - Italy  
Phone: +39 293 254 214

### Amphenol IBERICA

Edificio Burgosol, Oficina nr 55 - Comunidad  
de Madrid, 35-bis Las Rozas (Madrid) - Spain  
Phone: +34 91 640 73 06

### Amphenol NORDIC

Phone: +46 702 129 200 (Mil/Aero)  
+46 76-790 95 60 (Industrial)

### Amphenol AUSTRIA & CEE

Wiener Gasse 68  
2380 Perchtoldsdorf  
Phone: +43 699 10396071

### Amphenol POLAND

Lwowska 8/16,  
53-516 Wroclaw - Poland  
Phone: +48 513017157

### Amphenol SWITZERLAND & SOUTH CENTER

Switzerland, Slovenia, Serbia, Montenegro,  
Yugoslavia, Greece, Bulgaria  
948, promenade de l'Arve BP29  
74311 Thyez Cedex - France  
Phone: +33 (0)4 50 89 28 40

## Amphenol Sales contacts in Asia

### Amphenol DAESHIN

558 SongNae-Dong SoSa-Gu, Bucheon-city, Kyunggi-Do  
Korea 420-130  
Phone: +81-32 610 3830/3845

### Amphenol EAST ASIA LTD.

No.72, Bendemeer Road,  
#03-32/33, Luzerne  
Singapore 339941  
Phone: +65 6294 2128

### Amphenol INTERCONNECT INDIA PRIVATE LIMITED

105 Bhosari Industrial Area - Pune 411 026 - India  
Phone: +91 20 3068 8304

### Amphenol PCD CO. LTD

Building 21, 1st Liao Keng Industrial Zone, Shi Yan Street  
Bao An District, Shenzhen 518108  
China  
Phone: +86 755 8173 8000/8286

### Amphenol JAPAN

471-1, Deba, Ritto-City, Shiga 520 3041 - Japan  
Phone: +81 77 553 8501

## Amphenol Sales contacts in North America

### Amphenol PCD

72 Cherry Hill Drive - Beverly, MA. 01915 - USA  
Phone: +1 978 624 3400

### Amphenol FIBER SYSTEMS INT.

1300 Central Expwy N, Suite 100  
Allen, TX 75013 - USA  
Phone: +1 214 547 2400

### Amphenol AEROSPACE OPERATIONS

40-60 Delaware street - Sidney, NY 13838-1395 - USA  
Phone: +1 607 563 5011

### Amphenol BACKPLANE SYSTEMS

18 Celina avenue - Nashua, NH 03063 - USA  
Phone: +1 603 883 5100

### Amphenol CANADA CORPORATION

605 Milner avenue - Toronto, Ontario - Canada - M1B 5X6  
Phone: +1 416 291 4401

## Amphenol Sales contacts in Other Areas

### Amphenol ARGENTINA

Av. Callao 930 2do piso Oficina B "Plaza" C1023 - AAP  
Buenos Aires - Argentina  
Phone: +54 11 4815 6886

### Amphenol AUSTRALIA PTY LIMITED

2 Fiveways Blvd., Keysborough - Melbourne  
Victoria 3173- Australia  
Phone: +61 3 8796 8888

### Amphenol DO BRAZIL

Rua Diogo Moreira, 132, 20 andar, rooms 2001-2-3  
CEP: 05423-010 Sao Paulo SP - Brazil  
Phone: +55 11 3815 1003

### Bar-Tec Ltd., ISRAEL

3 Hagavish Street, K fir-Barkan Bldg. East Industrial  
Zone - Kfar-Sava, 44102 - Israel  
Phone: +972 9 764 4100

### Amphenol MEXICO

Prolongacion Reforma 61-6 B2  
Col Paseo de las Lomas - C.P. 013130 Mexico  
Phone: +52 55 5258 9984

### Amphenol RUSSIA

Yaroslavskaja Street 8,  
129164 Moscow - Russia  
Phone: +7 495 937 6341

### Amphenol AFRICA

30 Impala Rd,  
Sandton 2146, South Africa  
Phone: +27 82 410 5179

### Amphenol TURKEY

Sun Plaza 15 Kat: 15 Maslak Hah. Bilim Sok. No.5  
Sisli/Istanbul, 34398 - Turkey  
Phone: +90 212 367 92 19



[www.amphenol-socapex.com](http://www.amphenol-socapex.com)

For Technical Support, please contact us:  
+33 (0)4 50 89 28 49  
[www.amphenol-socapex.com/technical\\_support](http://www.amphenol-socapex.com/technical_support)

The information given in this document is a guideline only.  
We reserve the right to modify our products in any way we deem necessary.  
Any duplication is prohibited, unless approved in writing.  
Designed by Amphenol Socapex - November 2015

Your local Contact:

DOC-000084-ANG

For more information, please visit our websites:  
[www.rjfield.com](http://www.rjfield.com) - [www.usbfield.com](http://www.usbfield.com) - [www.fwfield.com](http://www.fwfield.com) - [www.rjswitch.com](http://www.rjswitch.com)