

# TapNLink TnL-FIR103 (BLE, NFC) Datasheet

13 July 2020  
Version 1.4

## Contents

1	Introduction .....	4
2	Summary .....	5
3	Block diagram .....	7
4	Development environment.....	8
4.1	TapNLink configuration.....	8
4.2	Software for Mobile Devices.....	8
4.3	Connectivity to a Cloud platform.....	9
5	Features.....	10
5.1	Communication channels .....	10
5.1.1	Near Field Communication (NFC) .....	10
5.1.2	Bluetooth Low Energy (BLE) .....	10
5.2	Target system interface .....	10
5.3	Security features.....	11
5.3.1	Access control configuration.....	11
5.4	Electrical characteristics .....	11
5.4.1	Power supply .....	11
5.4.2	Digital levels.....	11
5.5	RF specifications .....	12
5.6	Mobile device support.....	12
5.7	Cloud support .....	12
5.8	Operating temperature range .....	12
6	Pin assignment .....	13
6.1	J1 pinout .....	13
6.2	J3 pinout .....	14
6.3	P1 extension connector .....	14
7	Regulatory compliance .....	15
7.1	CE certification (Europe) .....	15
7.2	FCC (USA) and IC (Canada).....	15
7.2.1	FCC Part 15 compliance statement.....	15
7.2.2	Industry Canada Licence-Exempt Radio Apparatus .....	16
7.2.3	Radio Frequency (RF) Exposure Compliance of Radiocommunication Apparatus .....	16
7.2.4	End Product Labeling .....	16
7.2.5	End Product User's Manual:.....	16
8	Mechanical characteristics .....	17
8.1	Module dimensions.....	17
8.2	Standard plastic case .....	17

9	Ordering Information.....	18
9.1	Part Numbers, Options and Ordering Codes .....	18
9.2	Evaluation kit (Primer) .....	19
10	EU Declaration of Conformity (DoC) .....	20
11	History.....	22

# 1 Introduction

**IoTize™** offers a complete solution for migrating electronic systems to the Internet of Things (IoT). It is inspired by the advantages of adding network connectivity without redesigning existing systems or recoding their firmware.

IoTize's **TapNLink™** line uses technologies and techniques, which are typically reserved for system programming and debugging, to connect directly to the target system's microcontroller. This unique approach makes it possible to add connectivity without redesigning the target system. It also delivers design flexibility through simple encapsulation of complex wireless communication, network and security technologies. This facilitates the initial integration, but also makes it possible to easily evolve the wireless connection to meet future needs or technology evolutions... and still without ever recoding the system's original software.

TapNLink provides fully qualified wireless implementations. These allow connection to local mobile devices (smartphones, PDAs, tablets, PCs, etc.) allowing users to monitor or update a system and transfer data to the Cloud if/when necessary. Depending on the connectivity channels on the module, TapNLink can also enable connection to WAN or LPWAN for remote supervision and remote access control from the Cloud. To support Cloud integration, TapNLink leverages IoTize's system-to-Cloud IoT solution that is based on MQTT. This solution easily integrates both private and public Cloud platforms.

The complete TapNLink solution is implemented by configuration only. This minimizes the risks of IoT migration whether you are creating an early IoT proof-of-concept, retrofitting products for the IoT or designing new IoT-enabled products. In all cases, IoTize provides the required connectivity, ease-of-implementation and flexibility.

For the target embedded system, the TapNLink solution enables:

- Instant GUI on mobile devices (ex. smartphones, tablets, PDAs, etc.)
- Data transfers to the internet
- Secured and controlled access target system data

TapNLink provides software and hardware encapsulation of the communications between mobile devices and the target system. It manages communication with:

- Target systems via hardware module RF interface(s) and communication co-processor
- Mobile devices via a low-level service app

All IoTize wireless products integrate NFC (Near Field Communication) for:

- Direct contactless communication with the target system
- Secure wake up and pairing of mobile devices and other wireless interfaces (Bluetooth, BLE, Wi-Fi) which may be present on the IoTize product

## 2 Summary

The TapNLink NFC, Bluetooth Low Energy (BLE) module (Part N°: TnL-FIR103) offers instant integration of contactless/wireless interfaces to enable the connection of a microcontroller-based target system to mobile devices (smartphones, PDAs, tablets, PCs, etc.).

TapNLink connects directly the microcontroller of the target system and allows non-intrusive read and/or write access to variables in the target microcontroller's memory. The data addresses and access parameters for the target system are configured in the TapNLink. No (re)coding of the target system's native functionality is required to connect TapNLink to the target microcontroller.

TapNLink supports local connection to mobile devices (Android or iOS) so that data can be viewed and modified via a graphical user interface (GUI) app that is created by the target system designer. An initial test GUI app is automatically generated for the designer when TapNLink is configured. This test app serves as the foundation for the designer's app.

The TapNLink solution includes a software infrastructure that enables data transmission via the mobile device to any Cloud-based IoT service platform. This infrastructure is based on an open source MQTT relay and translators for common Cloud IoT platforms. It can be installed on servers and adapt to any private or public IoT Cloud platform.

### Communication Channels

- Near Field Communication (NFC) Type5 tag (ISO/IEC 15693)
- Bluetooth Low Energy (BLE) 4.1

### Target system interface protocols

- SWD debugging/programming interface protocol
- Software Secure Serial Port (S3P)

### Security features

- Configurable access profiles
- Configurable, encrypted passwords
- AES-128 module-level data encryption
- Configurable secure pairing with NFC

### Configurable target memory access controls

- Accessible data addresses: up to ~ 500
- User profiles: up to ~ 100
- Access capabilities: Read or Write or Read/Write

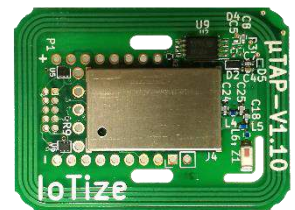

Electrical characteristics

- Input voltage: 2.3V to 3.6V
- Low power consumption:
  - Standby: 80  $\mu$ A
  - NFC Tx/Rx: 7 mA
  - BLE Tx/Rx: 15 mA

Mechanical characteristics

- Dimensions: 28 x 38 x 3 mm

Package options

- Bare board
- Plastic casing (IP44)
- Silicone resin (IP65)

Operating temperature range

- -20°C, +55°C

Compliance

- CE (Europe), FCC (USA), IC (Canada).
- REACH, RoHS

Design and Configuration Tools

- **IoTize Studio** configuration environment for Windows PCs. No license required. Free, no-registration [download from iotize.com](http://download.from.iotize.com).
- **Tap Manager** app for Android and iOS mobile devices. Free download and installation on [Google Play Store](https://play.google.com/store/apps/details?id=com.iosense.tapmanager) and [Apple App Store](https://apps.apple.com/au/app/tap-manager/id1441111111).
- **TapNLink Primer NFC-BLE** (Ref. N°: IOTZ-TAPNLINK-PRIMER-NB) evaluation kit for [purchase from iotize.com](http://purchase.from.iotize.com). Evaluation kit includes:

- Feature limited *TapNLink TnL-FIR103* wireless module
- *SensorDemo* sample STM32 microcontroller application and GUI sample app
- *Cloud Primer* IoT service platform, preconfigured and provisioned for logging data from TapNLink to the Cloud.



### 3 Block diagram

The TapNLink NFC, BLE module is equipped with two main integrated circuits:

- The STM32L432 microcontroller that executes the main program, manages the upper level protocols, the configuration and access control.
- The CYW20736 SoC which embeds the Cypress BLE stack and acts as a simple transmitter.

The matching circuitry for both the NFC and the BLE antennas are situated outside of the shielding. The NFC antenna is a trace at the periphery of the printed circuit board and the BLE. The 2.45 GHz antenna is a ceramic device located close to the L-shaped slot in the printed circuit board.

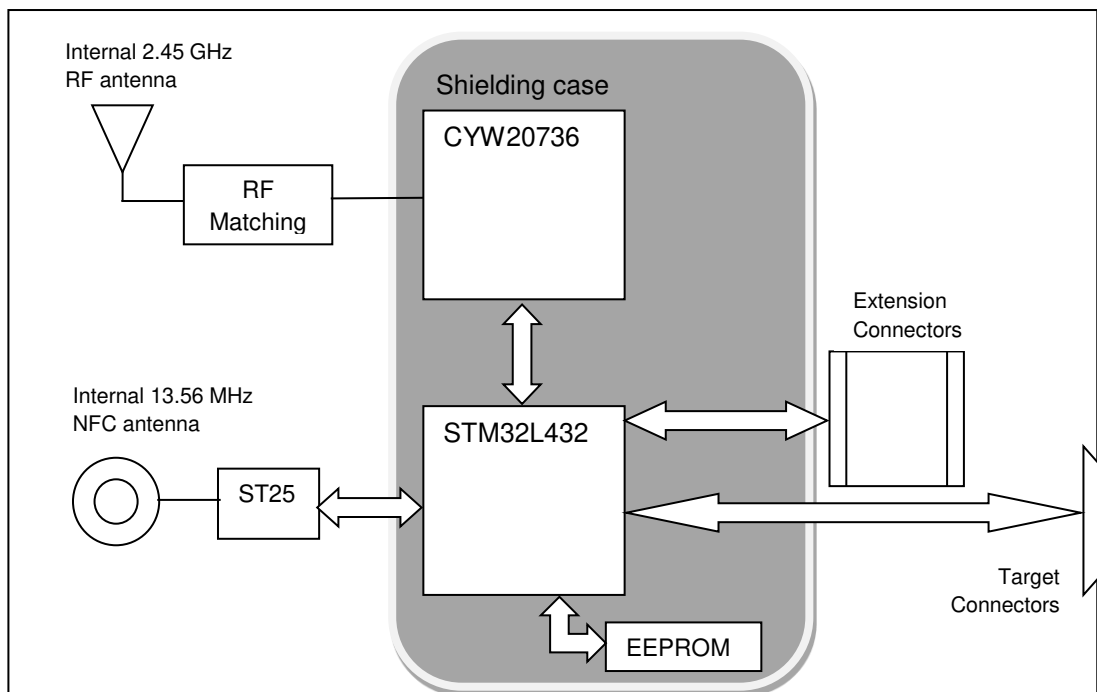

## 4 Development environment

### 4.1 TapNLink configuration

TapNLink is implemented by configuration only. Configuration is done with the free IoTize Studio software, which is available for download at <https://www.iotize.com/download.html>.

Note: a ten-minute video provides an overview of the integration and configuration - <https://www.iotize.com/video-iotize-tapnlink-demo.html>.

IoTize Studio provides a simple yet complete interface for managing the configuration of IoTize wireless modules so that they interface correctly with the target system. IoTize Studio provides:

- Drag-and-drop configuration of target data addresses using the source (ELF files) code of the target system
- Instant configuration transfer without extensive hardware installations
- Immediate configuration verification on the designer's PC and smartphone

When creating the TapNLink configuration, the designer imports the target system's firmware source file (ELF format). Designating the addresses to access via TapNLink is as easy as dragging-and-dropping them into the configuration project. All variable information (address, type, etc.) is copied directly from the firmware source file, which greatly reduces the risk of configuration errors. IoTize Studio also notifies the designer if the firmware source file is modified after the configuration has been created.

IoTize Studio allows users to transfer their configuration for testing and deployment with just the click of a button. IoTize Studio and TapNLink allow the transfer of the designer's configuration using a smartphone connection either directly with the designer's PC or via IoTize's Cloud-based MQTT relay. Thanks to this implementation no additional hardware is required during the design phase.

After configuration, the designer can connect to the module and visualize the results of the configuration in IoTize Studio's integrated app viewer. The app viewer shows the resulting user app exactly as it would display on a mobile device such as a smartphone. When the designer is satisfied with the configuration, visualizing the result on a mobile device requires only that the designer connect it to the TapNLink via one of the supported radio interfaces.

Read more about the configuration process, configurable parameters and tools in the [Technical Library](#) on the IoTize web site.

### 4.2 Software for Mobile Devices

TapNLink's *Tap Manager* app manages all communications interfaces for Android or iOS mobile devices. As a result, creating GUI apps to monitor system data on mobile devices can be as simple as generating and fine-tuning the HTML5 code and the CSS that are generated during the configuration of TapNLink.

Application notes are available in the IoTize website's [Technical Library](#), which describe how to design apps by adapting the generated HTML or by using the IoTize API to create native apps.



### **4.3 Connectivity to a Cloud platform**

TapNLink is supported by an MQTT-base relay for transferring data to and from Cloud IoT service platforms. Companies integrating TapNLink in their products may use the IoTize MQTT relay and IoTize servers. The MQTT relay is also an open source software that system designers are free to adapt to the own installations, servers and Cloud platforms.

More information about Cloud integration is provided in the [Technical Library](#) on the IoTize web site.

## 5 Features

The TapNLink NFC, Bluetooth Low Energy (BLE) module (root part number: TnL-FIR103) offers instant integration of contactless/wireless interfaces radio interfaces to enable the connection of a microcontroller-base target system to a local mobile device (smartphones, PDAs, tablets, PCs, etc.).

TapNLink connects directly to two GPIO on the microcontroller in the target system. These GPIOs can be either the target Microcontroller's debugging/programming port (ex. SWD) or any pair of GPIOs enabled by the IoTize S3P protocol (application relinking is required). The connection to the target microcontroller is non-intrusive and allows read and/or write access of variables in the target microcontroller's memory. The data addresses and access parameters for the target system are configured in the TapNLink using the IoTize Studio configuration environment. No coding of the target system's native functionality is required to connect TapNLink.

TapNLink communicates with local mobile devices via their NFC and/or BLE interfaces. The IoTize Communication Service app (Android or iOS) on the mobile device manages its communication interfaces, thus eliminating the need for the target-system designers to code or validate these mechanisms. Target system designers instead focus on creating the user interface for the target system.

With TapNLink NFC, BLE modules, a local mobile device can serve as a network gateway to bring data to or retrieve data from the Cloud. Data that is read by the TapNLink can be transmitted via the mobile device's data or network connection when available. For this, IoTize provides an MQTT-base relay with IoT Cloud platform translators. This MQTT infrastructure is open source software that designers of target systems can install on servers and adapt to any private or public IoT Cloud platform.

### 5.1 Communication channels

#### 5.1.1 Near Field Communication (NFC)

- Data transmission rate<sup>1</sup>: 2 kilobytes per second
- Range<sup>2</sup>: to 4 centimeters
- Supports use of NFC for dynamic wakeup and pairing of the BLE interface.

#### 5.1.2 Bluetooth Low Energy (BLE)

- Max power: 4 dBm (approx. 2.5 mW)
- Data transmission rate<sup>1</sup>: 0.5 kilobytes per second
- Range<sup>2</sup>: up to 30 meters

Notes:

1. Average speed while acquiring 1000 times 220 bytes from the target.
2. Measure line-of-site in an environment free of obstructions and rebound effects.

### 5.2 Target system interface

Requires 2 GPIO enabled by the target microcontroller's debug protocol or IoTize Simulated Secure Serial Port (S3P).

### 5.3 Security features

Customized firmware allows differentiated algorithms for each application. The communication chain is fully secured using classic techniques including:

- Authentication:    secured passwords or signed tokens
- Encryption:        AES-128

When implementing on GPIO enabled by the target microcontroller's debug protocol, data encryption is enabled to the level of the TapNLink module.

When implementing with S3P protocol, security features can be implemented on the target microcontroller. Features include data encryption and filtering of accessible addresses in the target's memory space.

#### 5.3.1 Access control configuration

IoTize stores access control data in 2KB of E<sup>2</sup>PROM:

- Accessible data addresses:    up to ~ 500
- User profiles:                   up to ~ 100
- Access rights:                   Read/Write
- Plus 3 predefined profiles of up to 96 characters.

### 5.4 Electrical characteristics

#### 5.4.1 Power supply

- Maximum DC supply voltage    3.9V
- DC supply voltage               2.3V to 3.6V
- Low power consumption:
  - Standby:                        80  $\mu$ A
  - NFC Tx/Rx:                     7 mA
  - BLE Tx/Rx:                     15 mA

When in standby mode, wake up of the Tap is possible by NFC.

#### 5.4.2 Digital levels

- Maximum voltage on input/output    V<sub>cc</sub> + 0.3V
- Minimum voltage on input/output    V<sub>ss</sub> - 0.3V
- Input low voltage (max)            0.4V
- Input high voltage (min)            0.75 x V<sub>cc</sub>

## 5.5 RF specifications

For details, see CYW20736 SoC specifications.

Parameter	Min	Typ	Max	Unit
Frequency range	2402	-	2480	MHz
Rx sensitivity		-93		dBm
Output power range	-20	3.0	3.0	dBm

## 5.6 Mobile device support

TapNLink includes radio implementations for NFC and BLE, which are compatible with a wide range of mobile devices running Android or iOS operating systems.

The IoTize Communication Service (ICS) app manages the radio interfaces on mobile devices running Android v4.0.3 and iOS v10 or later versions.

## 5.7 Cloud support

TapNLink includes an open source MQTT relay. Designers using TapNLink are free to copy and adapt this to meet their specific requirements for data exchanges with IoT Cloud platforms. Full information about IoTize Cloud support for TapNLink is provided in the IoTize MQTT Relay User Manual.

## 5.8 Operating temperature range

The behavior and the radio characteristics have been tested to guarantee a correct operation in the range of **-20°C - +55°C**.

**Important Note:** When the temperature is below -10°C, the startup time ( $t_s$ ) of the BLE advertising and the wake-up from low power mode (if configured) increase. The following delays in startup for BLE have been measured in product testing:

- For  $T > -10^\circ\text{C}$ ,  $t_s < 3$  s
- For  $T = -15^\circ\text{C}$ ,  $t_s = 20$  s
- For  $T = -20^\circ\text{C}$ ,  $t_s = 33$  s
- For  $T = -25^\circ\text{C}$ ,  $t_s = +/- 60$  s
- For  $T = -35^\circ\text{C}$ ,  $t_s = +/- 200$  s

This does not impact the NFC communication.

## 6 Pin assignment

The TapNLink BLE-NFC module has 3 connectors:

- J1 (2x5 in 1.27mm steps) that connects the TAP to the debug connector (ARM-SWD standard) of the target card via a flex cable (in 0.635mm steps).
- J3 (1x5 in 2.54mm steps) which connects the TAP to the target board more flexibly by free wires not necessarily grouped in tablecloth. Note that J3 is a subset of J1.
- P1 extension connector composed of two rows P1A and P1B of contacts in 2mm steps. This connector is mainly reserved for the addition of expansion cards and will only be briefly described in this document.

The following figure shows (bottom view) the signals connected to J1 and J3:

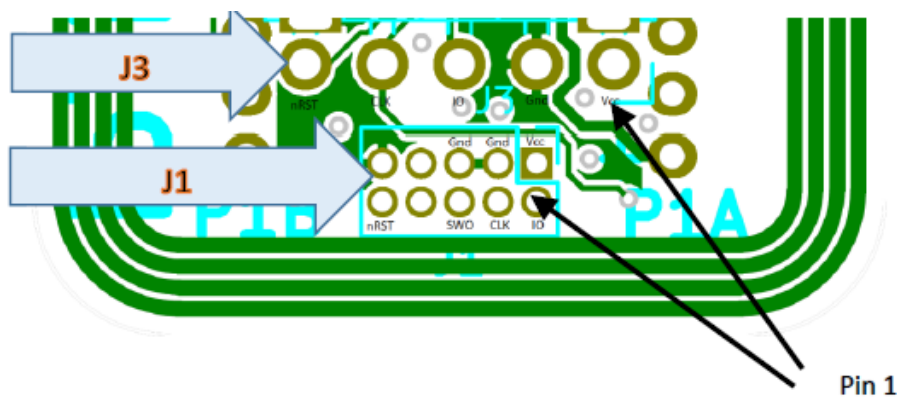

### 6.1 J1 pinout

This connection corresponds to the format specified by ARM for Cortex-M microcontrollers

Vcc	1	•	•	2	S3PIO/SWDIO (TMS)
Gnd	3	•	•	4	S3PCLK/SWDCLK (TCK)
Gnd	5	•	•	6	SWO (TDO)
Not connected	7	•	•	8	-- (TDI)
Gnd	9	•	•	10	nRST

**Note:** The names in parentheses correspond to the JTAG protocol. In general, it is advisable to prefer SWD to JTAG on Cortex-M microcontrollers. For any other microcontroller, use the S3P protocol.

The signals to be connected in SWD or S3P are:

- Gnd
- Vcc (the target must provide the TAP power),
- S3PIO/SWDIO, a bi-directional data signal.
- S3PCLK/SWDCLK, the clock signal, bi-directional in S3P.
- NRST: Reset signal of the target processor. Its connection is optional. It should be maintained if you want to use the reset command, or if you want to use the TAP as a programmer (the reset signal is required in some programming situations).

## 6.2 J3 pinout

J3, a 2.54mm-step connector, is an inexpensive and robust connector that can connect to a wide range of other connectors. It is easier to use than the alternative 20-point ARM 2.54mm-step standard.

J3 does not correspond to a specific standard. It contains the main signals necessary for S3P and SWD protocols:

Vcc	1	●
Gnd	2	●
S3PIO/SWDIO	3	●
S3PCK/SWDCK	4	●
nRST	5	●

## 6.3 P1 extension connector

P1 extension connector is composed of two mechanically independent parts:

- P1A has 8 points
- P1B has 10 points (8 + 2 additional points). The two additional points are used exclusively for initial programming.

Most of the signals on the expansion connector are reserved for extensions proposed by IoTize. This connector will only be used in exceptional situations, for example, if it is necessary to control the reset of the TAP, or use UART (P1B.7: TxUART, P1B.8: RxUART).

The figure below shows the position of the TAP's power, reset and wakeup points.

		●	P1B.10
		●	P1B.9
		●	P1B.8 / RxUART
		●	P1B.7 / TxUART
		●	P1B.6
		●	P1B.5
		●	P1B.4
		●	P1B.3 / Tap_Wakeup
		●	P1B.2
		●	P1B.1 / Gnd
P1A.8	●		
P1A.7	●		
P1A.6	●		
Tap_nRST / P1A.5	●		
P1A.4	●		
P1A.3	●		
P1A.2	●		
Vcc / P1A.1	●		

## 7 Regulatory compliance

Any changes or modifications not expressly approved by IOTIZE S.A.S. may void the user's authority to operate the equipment.

TapNLink TnL-FIR103 is tested and qualified under the following standards:

### 7.1 CE certification (Europe)

The TapNLink TnL-FIR103 operating range corresponds to:

- Frequency Band: 2400-2483.5MHz
- Maximum Transmitting Power: 10mW (EIRP)

This device has been tested and certified for use in the European Union and IOTIZE hereby declares that the device "TapNLink TnL-FIR103" is in conformity with the essential requirements of Directive 2014/53/EU. The complete Declaration of Conformity can be found at:

- Appendix 1 of the present notice,
- [www.iotize.com](http://www.iotize.com) for the electronic version.

If this device is used in a product, the OEM has responsibility to verify compliance of the final product to the EU standards. A Declaration of Conformity must be issued and kept on file. The 'CE' mark must be placed on the OEM product per the labeling requirements of the Directive.

### 7.2 FCC (USA) and IC (Canada)

#### 7.2.1 FCC Part 15 compliance statement

This device complies with part 15 of the FCC Rules. Operation is subject to the following two conditions: (1) This device may not cause harmful interference, and (2) this device must accept any interference received, including interference that may cause undesired operation.

NOTE: This equipment has been tested and found to comply with the limits for a Class B digital device, pursuant to part 15 of the FCC Rules. These limits are designed to provide reasonable protection against harmful interference in a residential installation. This equipment generates uses and can radiate radio frequency energy and, if not installed and used in accordance with the instruction, may cause harmful interference to radio communications. However, there is no guarantee that interference will not occur in a particular installation. If this equipment does cause harmful interference to radio or television reception which can be determined by turning the equipment off and on, the user is encouraged to try to correct interference by one or more of the following measures:

- Reorient or relocate the receiving antenna.
- Increase the separation between the equipment and receiver.
- Connect the equipment into an outlet on circuit different from that to which the receiver is connected.
- Consult the dealer or an experienced radio/TV technician for help.

### 7.2.2 Industry Canada Licence-Exempt Radio Apparatus

This device complies with Industry Canada licence-exempt RSS standard(s). Operation is subject to the following two conditions: (1) this device may not cause interference, and (2) this device must accept any interference, including interference that may cause undesired operation of the device.

Le présent appareil est conforme aux CNR d'Industrie Canada applicables aux appareils radio exempts de licence. L'exploitation est autorisée aux deux conditions suivantes : (1) l'appareil ne doit pas produire de brouillage, et (2) l'utilisateur de l'appareil doit accepter tout brouillage radioélectrique subi, même si le brouillage est susceptible d'en compromettre le fonctionnement.

### 7.2.3 Radio Frequency (RF) Exposure Compliance of Radiocommunication Apparatus

This device complies with FCC and Industry Canada RF radiation exposure limits set forth for general population (uncontrolled exposure). This device must not be collocated or operating in conjunction with any other antenna or transmitter.

Cet appareil est conforme aux limites FCC et Industrie Canada concernant l'exposition aux rayonnements RF établies pour le grand public. (Environnement non-contrôlé) Cet émetteur ne doit pas être co-situé ou fonctionner conjointement avec une autre antenne ou un autre émetteur.

### 7.2.4 End Product Labeling

#### 7.2.4.1 FCC Certification

The final end product must be labeled in visible area with the following:

“Contains Transmitter Module FCC ID: 2APCX-TNLFIR10”  
or “Contains FCC ID: 2APCXTNLFIR10”

#### 7.2.4.2 IC Certification

The final end product must be labeled in visible area with the following:

L'équipement final doit être étiqueté sur un endroit visible avec le texte suivant :

“Contains IC: 23741-TNLFIR10”

### 7.2.5 End Product User's Manual:

The user manual for end users must include the following information in a prominent location:

“IMPORTANT NOTE:

To comply with FCC RF exposure compliance requirements, the antenna used for this transmitter must not be collocated or operating in conjunction with any other antenna or transmitter.”



## 8 Mechanical characteristics

### 8.1 Module dimensions

The main dimensions are noted in the diagram below (bottom view):

- Dimensions<sup>3</sup>: 28 x 38 x 3 mm
- Weight: 3 g

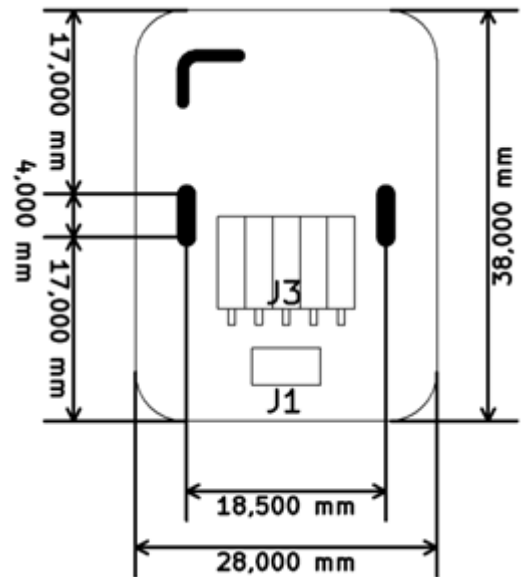

### 8.2 Standard plastic case

An optional plastic casing is available from IoTize to facilitate integration in to finished products. The plastic casing holds the TapNLink module at an optimal position to ensure interoperability, notably of the NFC interface.

The plastic case can be fixed in place using screws or adhesives. Screws and adhesives are not available from IoTize.

The case's flange makes it possible to add a protective O-ring in applications that require a water or dust resistant seal. Seals and O-rings are not available from IoTize.

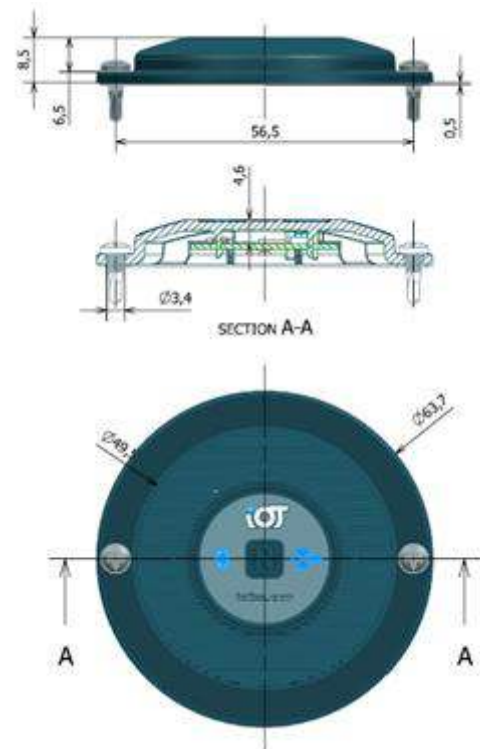

## 9 Ordering Information

All prices include at a minimum the TapNLink modules pre-qualified, pre-programmed and ready to configure. Pricing also includes software for mobile device user interface implementation (IoTize Communication Service – ICS) and the IoTize Cloud MQTT infrastructure (open source). For product configuration, pricing includes IoTize Studio configuration and testing environment for Windows PCs, and infrastructure for device configuration via a smartphone connection (Wi-Fi, BLE) or via the IoTize MQTT broker/relay.

The **TapNLink TnL-FIR103** is available for purchase in an off-the-shelf configuration without optional connectors or connection cables. Off-the-shelf packages are available in MOQ of 10 units via the [www.iotize.com](http://www.iotize.com) online store or by emailing [contact@iotize.com](mailto:contact@iotize.com).

For quantities of more than 500 units, email [contact@iotize.com](mailto:contact@iotize.com) for price quotes and lead times.

### 9.1 Part Numbers, Options and Ordering Codes

Base part number: TnL-FIR103

Current part numbers for available options:

Product Line	Use Mode	Physical Interface	Radio Interface <sup>1</sup>	Product Prefix	Security	Casing Type	Power Supply
<b>TnL</b>	<b>F</b>	<b>I</b>	<b>R</b>	<b>10</b>	<b>3</b>	<b>-0</b>	<b>-TO</b>

**Product Lines:** TnL = TapNLink<sup>2</sup>

**Use Mode:** **F** = Fixed (powered by target system)

**Physical interface:** **I** = SWD/S3P

**Radio interface:** T = NFC only, **R = BLE**, W = Wi-Fi, B = Bluetooth Classic, L = BLE, LoRa

**Security:** 1 = Primer, 2 = Low, **3 = software based security**, 5 = hardware based security with embedded secure element.

**Casing Type<sup>3</sup>:** **-0** = No casing option selected

**Power Supply:** **-TO** = Powered by target system only

Notes:

1. All modules include NFC by default for advanced functionalities such as secure wake up and pairing.
2. The features of the part number shown in the table are indicated in bold.
3. The ABS plastic casing is available as an option with its specific type number.

## Ordering Codes

Ordering codes vary depending on the source and mode of purchase. When purchasing directly from IoTize the following ordering codes are used

Mode of Purchase	Quantity	Ordering Code	Pricing
<b>OEM production order</b> <sup>1</sup>	MOQ = 2000	TnL-FIR103-0-TO	Contact for pricing <sup>1</sup>
<b>Web purchase from available stocks</b> <sup>2</sup>	20	TnL-FIR103_P1	<a href="#">Available online</a> <sup>2</sup>
	100	TnL-FIR103_P2	<a href="#">Available online</a> <sup>2</sup>

Note 1: Purchase by quotation. Lead times will vary depending on production cycle. For more, information email [contact@iotize.com](mailto:contact@iotize.com).

Note 2: Purchase online or from registered IoTize distributors. Visit [www.iotize.com](http://www.iotize.com), or email [contact@iotize.com](mailto:contact@iotize.com) for more information.

Products are packaged in quantities of 20 pieces. MOQ = 20 pieces.



## 9.2 Evaluation kit (Primer)



The TnL-FIR103 evaluation kit, called TapNLink Primer NFC-BLE, is a complete hardware/software sample implementation that you can reconfigure to create your an IoT proof-of-concept for your microcontroller based system in just minutes. It includes:

- Feature limited *TapNLink TnL-FIR103* wireless module
- *SensorDemo* sample STM32 microcontroller application and GUI sample app
- *Cloud Primer* IoT service platform, preconfigured and provisioned for logging data from TapNLink to the Cloud.
- Plastic module casing,
- 5-wire cable to connect the to a target application board.



Description	MOQ	Ordering Code	Pricing
<b>TapNLink Primer NFC-BLE</b>	1	IOTZ-TAPNLINK-PRIMER-NB	34.00 Eur <a href="#">Buy online</a>

## 10 EU Declaration of Conformity (DoC)

EU Declaration of Conformity (DoC)										
<b>We, the undersigned:</b>	IoTize S.A.S. 17, avenue Jean Kuntzmann 38330 Montbonnot St Martin France Email: <a href="mailto:contact@iotize.com">contact@iotize.com</a> Phone : +33 4 76 41 87 99									
<b>Designated product:</b>	<b>TapNLink Bluetooth Low Energy module</b>  Part number: TnLFIR103 Frequency band 1: 2400-2483.5MHz Max Power: 10mW (e.i.r.p)									
<b>Certify and declare:</b>	under our sole responsibility that the designated product is in conformity with the essential requirements and provisions of the following European Directives:									
	<input checked="" type="checkbox"/> Directive 2014/53/EU of the European Parliament and of the Council of 16 April 2014 on the harmonisation of the laws of the Member States relating to the making available on the market of <b>radio equipment (RED)</b> . <i>The conformity of the designated product(s) with the provisions of this European Directive is given by the compliance with the following European Standard(s):</i>									
	<table border="1"> <tr> <td>Essential requirements of article 3.1a) of RED: (Safety, electrical)</td> <td>- EN 60950-1 (2006+A11/2009+A1/2010+A12/2011+A2/2013)</td> </tr> <tr> <td>Essential requirements of article 3.1a) of RED: (Safety, health)</td> <td>- EN 62479 (2010)</td> </tr> <tr> <td>Essential requirements of article 3.1b) of RED: (Electromagnetic Compatibility)</td> <td>- ETSI 301 489-1 (V2.1.1 + Draft V2.2.0) - ETSI 301 489-17 (V3.1.1 + Draft V3.2.0)</td> </tr> <tr> <td>Essential requirements of article 3.2) of RED: (Efficient use of radio spectrum)</td> <td>- ETSI EN 300 328 (V2.1.1)</td> </tr> </table>	Essential requirements of article 3.1a) of RED: (Safety, electrical)	- EN 60950-1 (2006+A11/2009+A1/2010+A12/2011+A2/2013)	Essential requirements of article 3.1a) of RED: (Safety, health)	- EN 62479 (2010)	Essential requirements of article 3.1b) of RED: (Electromagnetic Compatibility)	- ETSI 301 489-1 (V2.1.1 + Draft V2.2.0) - ETSI 301 489-17 (V3.1.1 + Draft V3.2.0)	Essential requirements of article 3.2) of RED: (Efficient use of radio spectrum)	- ETSI EN 300 328 (V2.1.1)	
Essential requirements of article 3.1a) of RED: (Safety, electrical)	- EN 60950-1 (2006+A11/2009+A1/2010+A12/2011+A2/2013)									
Essential requirements of article 3.1a) of RED: (Safety, health)	- EN 62479 (2010)									
Essential requirements of article 3.1b) of RED: (Electromagnetic Compatibility)	- ETSI 301 489-1 (V2.1.1 + Draft V2.2.0) - ETSI 301 489-17 (V3.1.1 + Draft V3.2.0)									
Essential requirements of article 3.2) of RED: (Efficient use of radio spectrum)	- ETSI EN 300 328 (V2.1.1)									
	<input checked="" type="checkbox"/> Directive 2011/65/EU of the European Parliament and of the Council of 8 June 2011 on the restriction of the use of certain hazardous substances ( <b>ROHS</b> ) in electrical and electronic equipment.									
	<input checked="" type="checkbox"/> Directive 2012/19/EU of the European Parliament and of the Council of 4 July 2012 on waste electrical and electronic equipment ( <b>WEEE</b> ).									
<b>Important hints:</b>	RED approval is only valid for products in delivery state, including standard hardware and software. TapNLink Bluetooth Low Energy modules are components which are delivered to OEM manufacturers for their use (integration) in final or combined products. It is the responsibility of the OEM manufacturer to demonstrate compliance with all applicable EU directives and standards. The IoTize declaration of conformity serves as input to the declaration of conformity for the final product.									
		TapNLink DoC, page 1 of 2								

## EU Declaration of Conformity (DoC)



At the time of writing following documents guidance have been published:

Blue Guide:

<http://ec.europa.eu/DocsRoom/documents/18027/>

RED Guide:

<http://ec.europa.eu/docsroom/documents/23321>

Specifically, within the new RED framework, all OEM manufacturers have for instance to fulfill the following additional requirements:

- Provide product branding clearly identifying company name or brand and product name as well as type, charge or serial number for market surveillance
- Include documentation containing full postal address of the manufacturer as well as radio frequency band and maximum transmitting power
- Include a user manual, safety information and a declaration of conformity for the final product in local language
- Provide product development and test documentation upon request

**The technical construction file is kept available at:**

IoTize S.A.S.  
17, avenue Jean Kuntzmann  
38330 Montbonnot St Martin  
FRANCE  
Phone : +33 4 76 41 87 99

**Issued on April 10<sup>th</sup> 2018,**

**Name and position of person binding the manufacturer or his authorised representative:**

Name: Francis Lamotte  
Position: President  
Email: [francis.lamotte@iotize.com](mailto:francis.lamotte@iotize.com)

Signature:



TapNLink DoC, page 2 of 2

## 11 History

Date	Version	Author	Modification
Dec 20 <sup>th</sup> 2017	1.0	SG	First release version.
Feb 15 <sup>th</sup> 2018	1.1	FL	Update dimensions and current consumption.
Apr 10 <sup>th</sup> 2018	1.2	SG	Compliance information (CE/FCC/IC).
Nov 9 <sup>th</sup> 2018	1.3	SG	Update product introduction, descriptions and ordering information
Jul 13 <sup>th</sup> 2020	1.4	JH	Update with P1 UART pins

### Disclaimer

Information in this document is subject to change without notice and does not represent a commitment on the part of the author(s).

No part of this document may be reproduced or transmitted in any form or by any means, electronic or mechanical, including photocopying, recording, or information storage and retrieval systems, for any purpose other than the development of the IoTize™ technology, without prior written permission from IoTize SAS and the IoTize™ consortium members.

Every effort has been made to ensure the accuracy of this manual and to give appropriate credit to persons, companies and trademarks referenced herein.

This document exists in electronic form (pdf) only.

### Copyright © IoTize All rights reserved

*IoTize™ is a registered trademark of IoTize SAS. All other registered names and trademarks are the property of their respective owners.*