

THIS DRAWING IS UNPUBLISHED. RELEASED FOR PUBLICATION
 BY - ALL RIGHTS RESERVED.

LOC	DIST	REVISIONS			
P	LTR	DESCRIPTION	DATE	DWN	APVD
DY	-	S OBSOLETE PART NUMBERS	26FEB2019	SS	PS

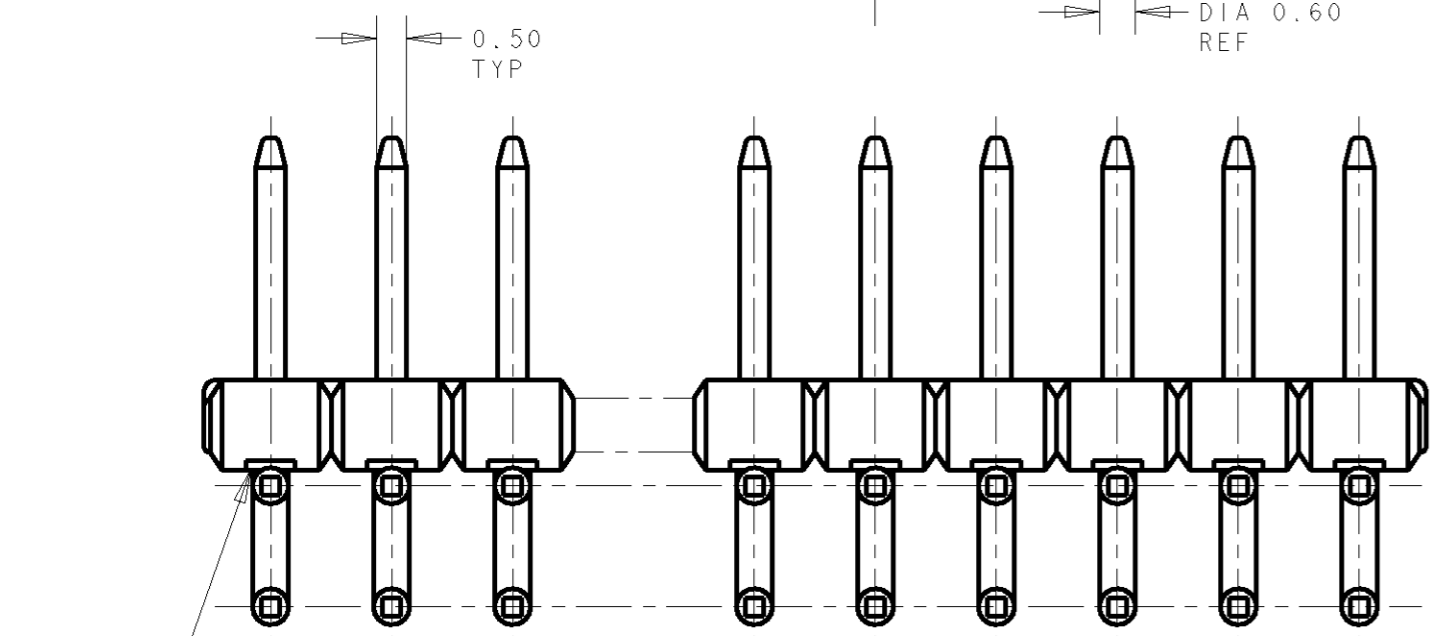
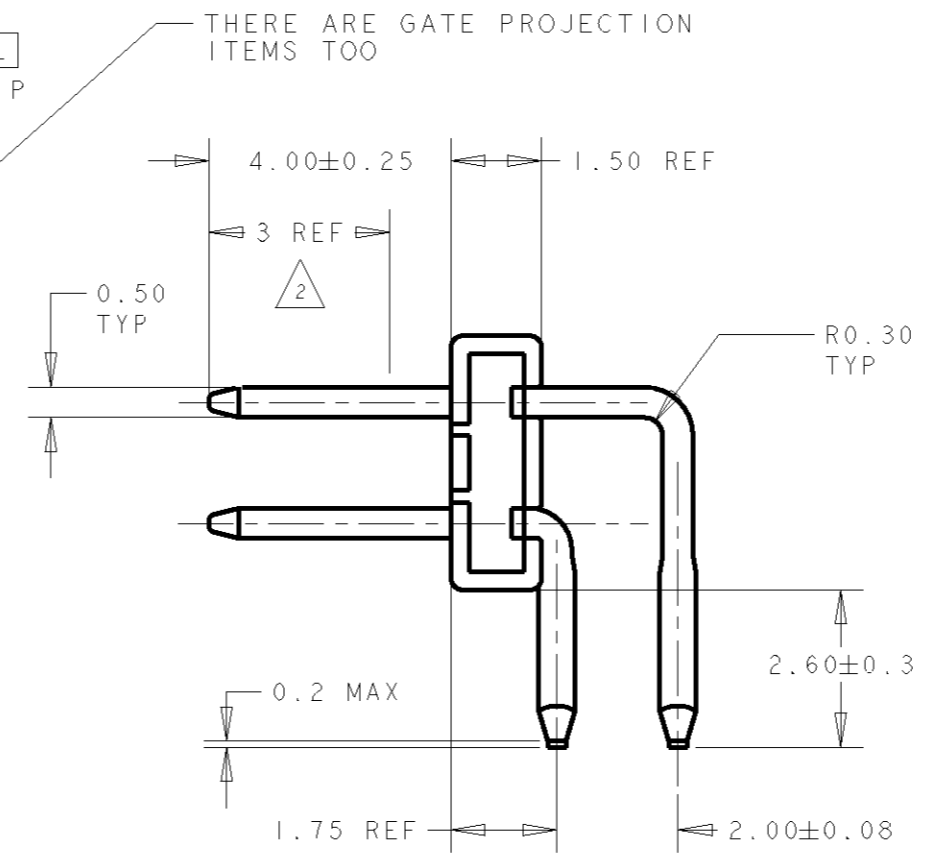
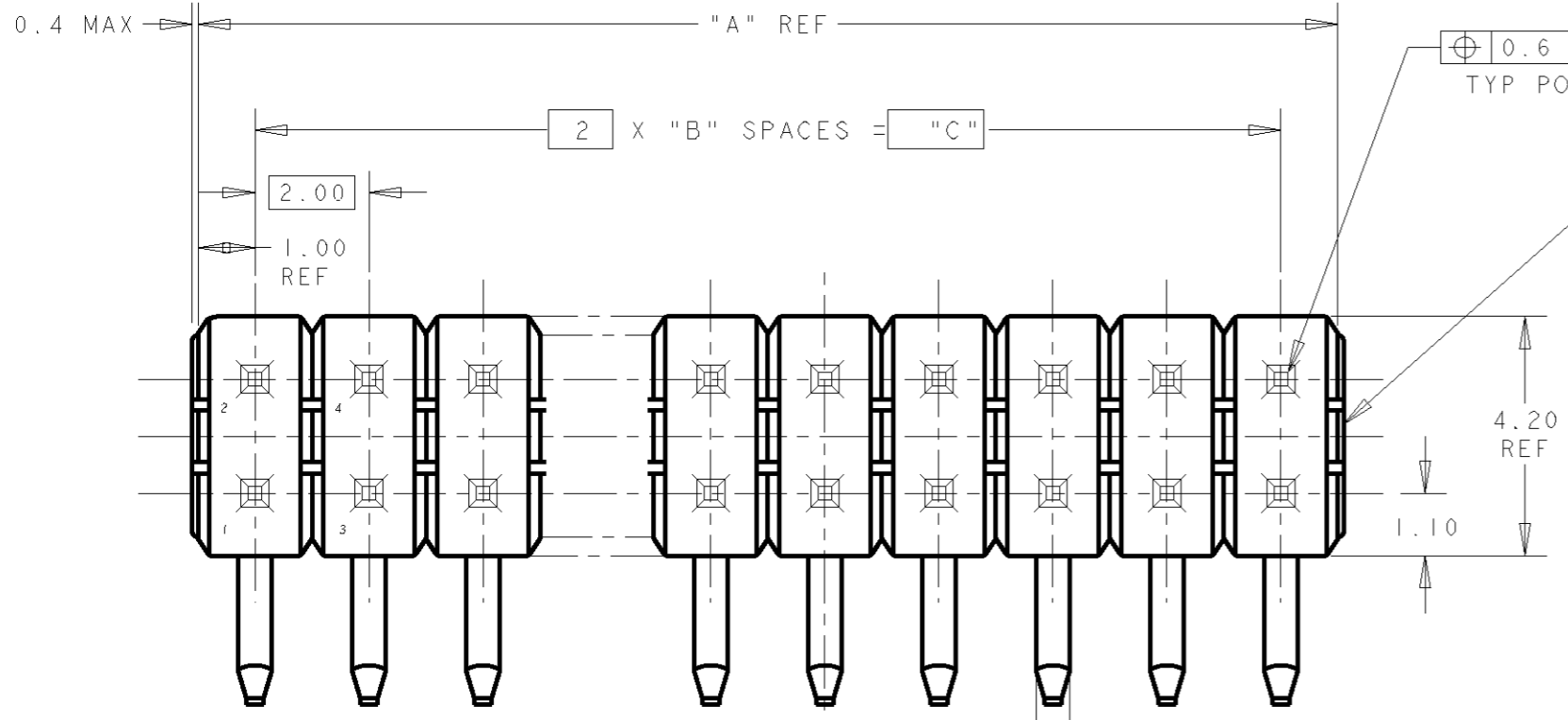

NOTES:

- 1 MATERIAL HOUSING: THERMOPLASTIC, UL 94V-0. COLOR: BLACK POST : BRASS
- 2 FINISH CONTACT AREA, "D" MIN Au ON NICKEL 0.0013 MIN ALL OVER POST TINE: 0.001 MIN MATTE TIN
- 3 FINISH 0.0025 MIN MATTE TIN OVER 0.0013 MIN ON ENTIRE POST
- 4. PACKAGING TUBE 0.5mm THK, LENGTH=635mm

OBSOLETE

3	NIL	NIL	14	7	16	16	5-	-3
3	NIL	NIL	38	19	40	40	5-	-2
	5, 16		14	7	16	16	5-	-1
	3, 16		14	7	16	16	5-	-0
	1, 8		6	3	8	8	4-	-9
	NIL		48	24	50	50	4-	-8
			46	23	48	48	4-	-7
			44	22	46	46	4-	-6
			40	20	42	42	4-	-4
			36	18	38	38	4-	-2
			34	17	36	36	4-	-1
			32	16	34	34	4-	-0
			30	15	32	32	3-	-9
			26	13	28	28	3-	-7
			20	10	22	22	3-	-4
			18	9	20	20	3-	-3
			16	8	18	18	3-	-2
			12	6	14	14	3-	-0
			4	2	6	6	2-	-6
		0.76µm	2	1	4	4	2-	-5
			48	24	50	50	2-	-4
			46	23	48	48	2-	-3
			44	22	46	46	2-	-2
			42	21	44	44	2-	-1
			40	20	42	42	2-	-0
			38	19	40	40	1-	-9
			36	18	38	38	1-	-8
			30	15	32	32	1-	-5
			28	14	30	30	1-	-4
			24	12	26	26	1-	-2
			16	8	18	18		-8
			14	7	16	16		-7
			12	6	14	14		-6
			10	5	12	12		-5
			8	4	10	10		-4
			6	3	8	8		-3
			2	1	4	4		5176837-1

"AMP" TRADE MARKS

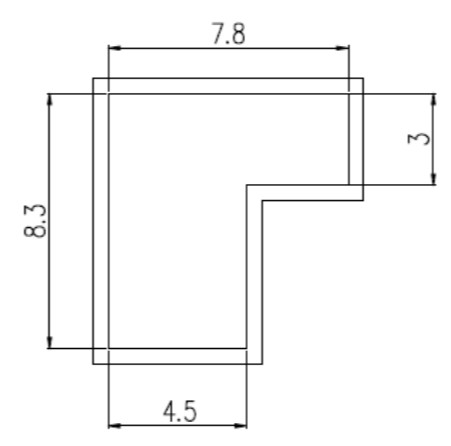
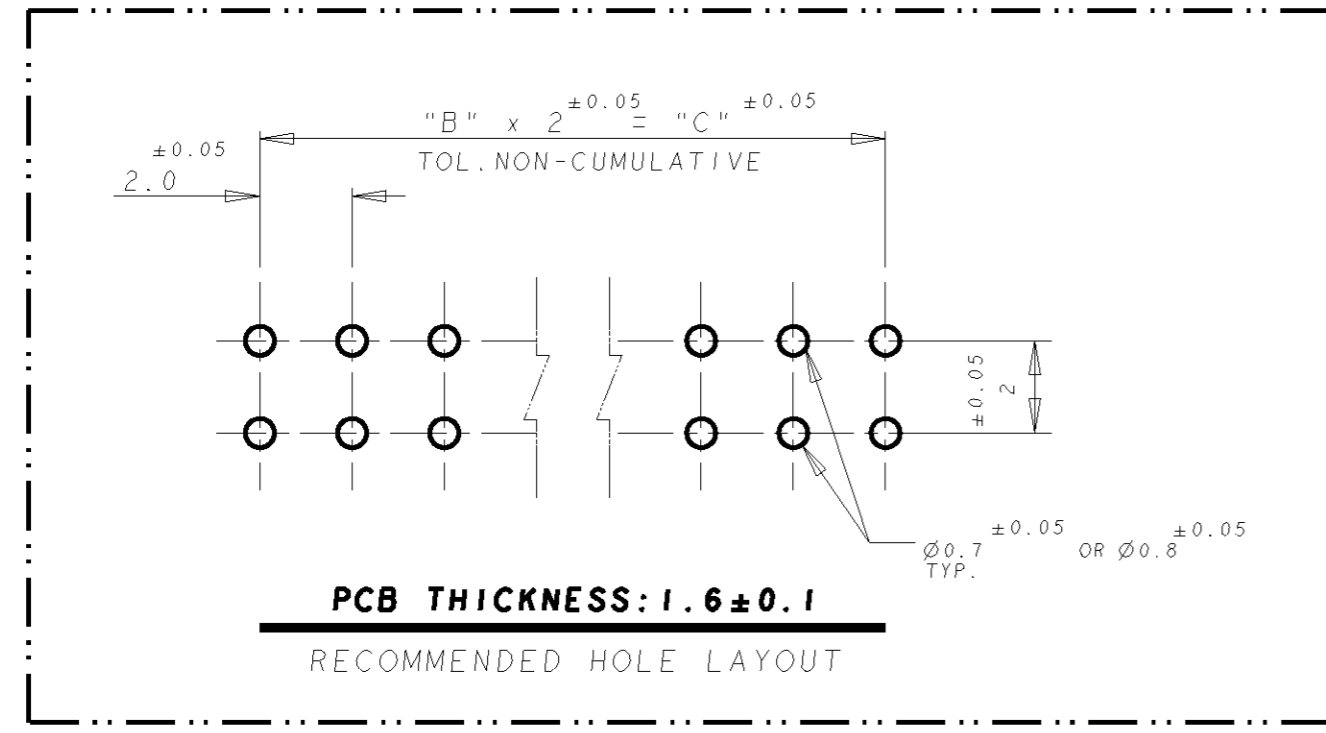

GENERAL TOLERANCE	
0 < L < 10	±0.2
10 < L < 30	±0.25
30 < L < 100	±0.3
ANGLES	±3°

DIMENSIONS:		TOLERANCES UNLESS OTHERWISE SPECIFIED:	
mm		0 PLC	±0.25
		1 PLC	±0.2
		2 PLC	±0.2
		3 PLC	±
		4 PLC	±
		ANGLES	±
		FINISH	

DWN	WYLEE	07MAR2005
CHK	VINCENT TAN	
APVD	SE LEONG	
PRODUCT SPEC		
APPLICATION SPEC		
WEIGHT		
CUSTOMER DRAWING		

STE TE Connectivity

NAME: AMPMODU 2mm PITCH POST HDR, HORIZONTAL TYPE, L=2.6

SIZE: A2 CAGE CODE: 00779 DRAWING NO: 5176837

SCALE: - SHEET: OF REV: S