

# Standard Product Specifications

**NAG161PH-F**

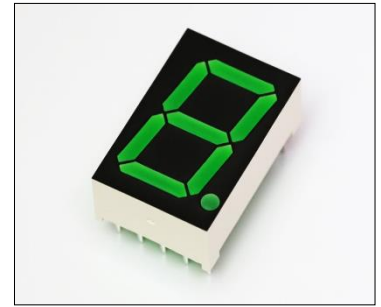

## Features

Package	Character height : 15.24mm (0.6inches) size numeric display, Anode common circuit, Black color face, Emitting color : Green, Super bright product
Product features	<ul style="list-style-type: none"> <li>•Outer dimension 19 x 12.5 x 12mm ( L x W x H )</li> <li>•Pb-free soldering compatible</li> <li>•RoHS compliant</li> </ul>

## Recommended Applications

- Amusement machine, Home appliances, OA/FA use, Various indicators, etc.

# Outline Dimensions

# NAG161PH-F

Unit : mm  
Weight : 2.187g  
Tolerance : ±0.25

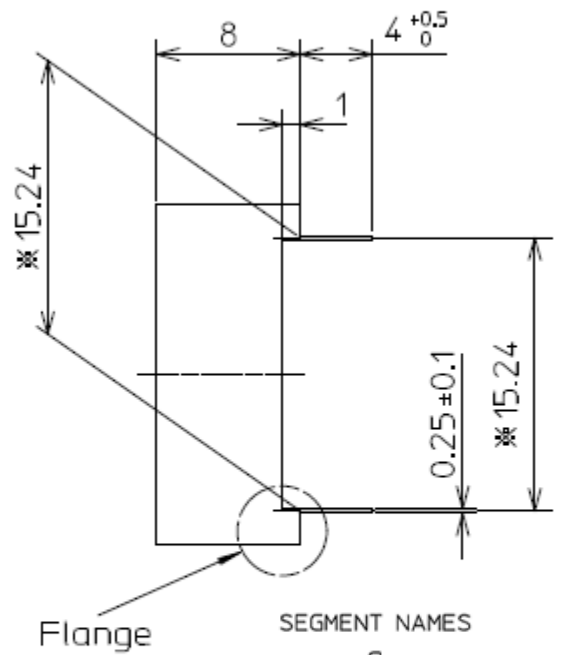
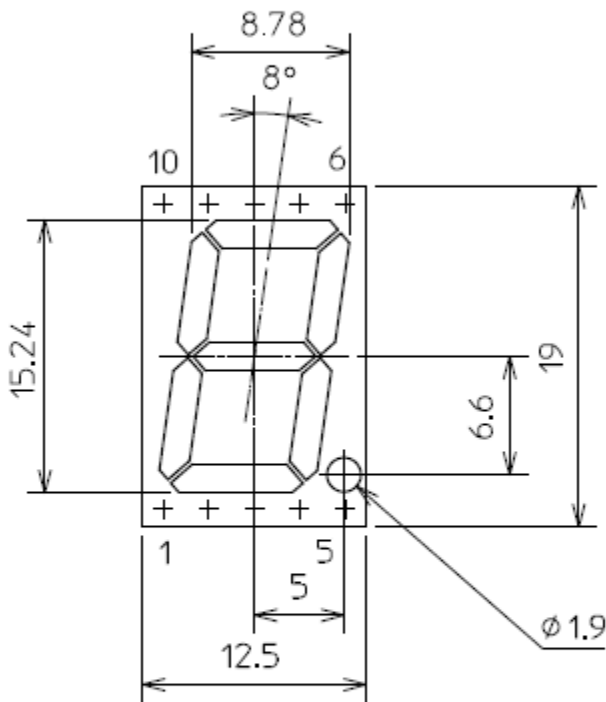
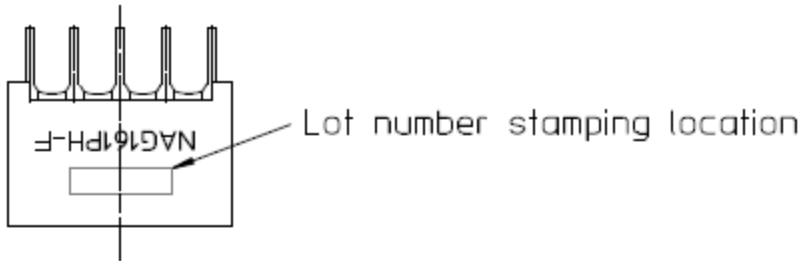

SEGMENT NAMES



The length of ※ is from the root of lead.

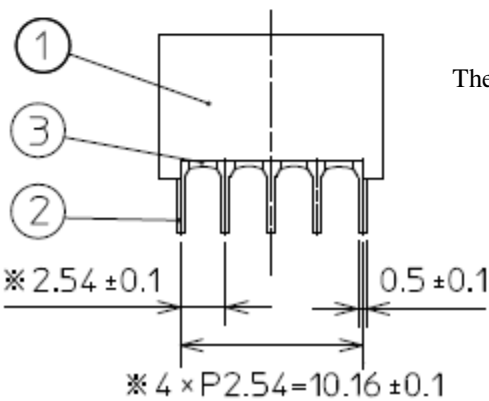

Internal circuit diagram  
(Anode common)

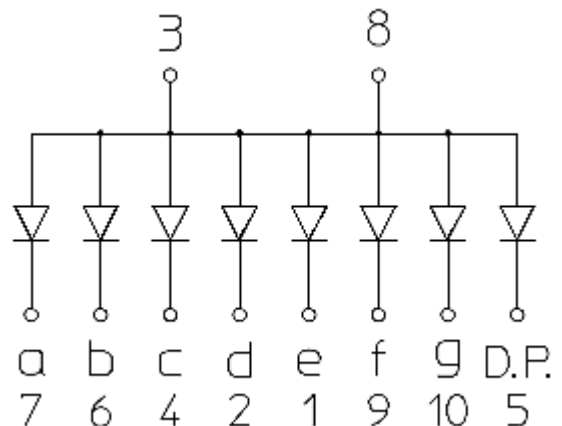

NO.	PART NAME	MATERIAL	QTY.
-	LED Die	AlGaInP	8
①	Lamp Housing	Resin	1
②	Lead	Pb free Solder plating	10
③	Encapsulant	Epoxy Resin	-

## 【 Product Overview 】

DIE MATERIAL	AlGaInP
EMITTING COLOR	Green
RESIN COLOR (EMITTING AREA)	Green
FACE COLOR	Black

## 【 Absolute Maximum Ratings 】

ITEM	SYMBOL	MAXIMUM RATINGS	UNITS
Power Dissipation	$P_d$	37	mW/seg.
Continuous Forward Current	$I_F$	15	mA/seg.
Repetitive Peak Forward Current 【 $f=1\text{KHz}$ , Duty $\leq 1/5$ 】	$I_{FRM}$	100	mA/seg.
$I_F$ Derate Linearly 【 from $T_a=25^\circ\text{C}$ 】	$\Delta I_F$	0.20	mA/ $^\circ\text{C}$
$I_{FRM}$ Derate Linearly【 from $T_a=25^\circ\text{C}$ 】 【 $f=1\text{KHz}$ , Duty $\leq 1/5$ 】	$\Delta I_{FRM}$	1.33	mA/ $^\circ\text{C}$
Reverse Voltage	$V_R$	5	V
Operating Temperature	$T_{opr}$	-30 ~ +85	$^\circ\text{C}$
Storage Temperature	$T_{stg}$	-30 ~ +85	$^\circ\text{C}$

## 【 Electro and Optical Characteristics 】

ITEM	SYMBOL	CONDITIONS	MIN.	TYP.	MAX.	UNITS	
Forward Voltage	$V_F$	$I_F = 10\text{mA}$	1.4	-	2.4	V/seg.	
Reverse Current	$I_R$	$V_R = 5\text{V}$	-	-	100	$\mu\text{A}/\text{seg.}$	
Luminous Intensity	a~g seg.	$I_V$	$I_F = 10\text{mA}$	3.5	7.0	10.5	mcd/seg.
	D.P. seg.		$I_F = 10\text{mA}$	0.8	1.6	2.0	mcd/seg.
Dominant Wavelength	$\lambda_d$	$I_F = 10\text{mA}$	-	570	-	nm	

Note Above the table of Luminous Intensity ( $I_V$ ) values and Dominant Wavelength ( $\lambda_d$ ) values are the setup value of the selection machine.

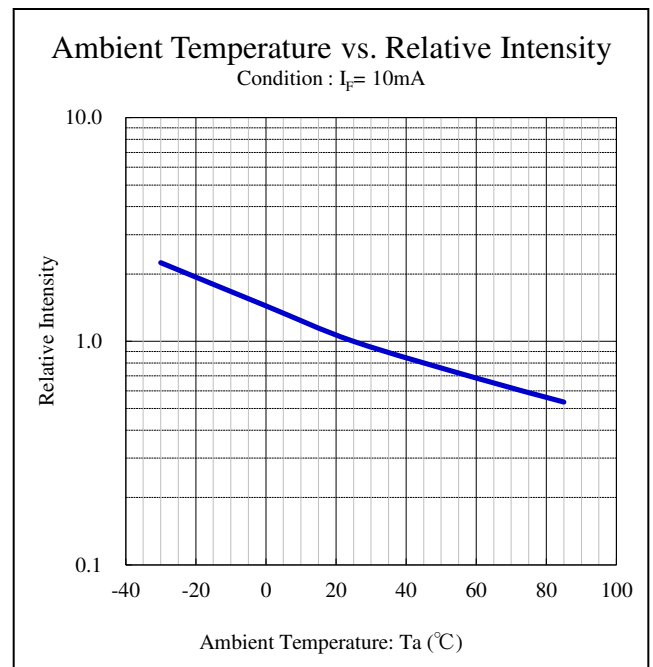
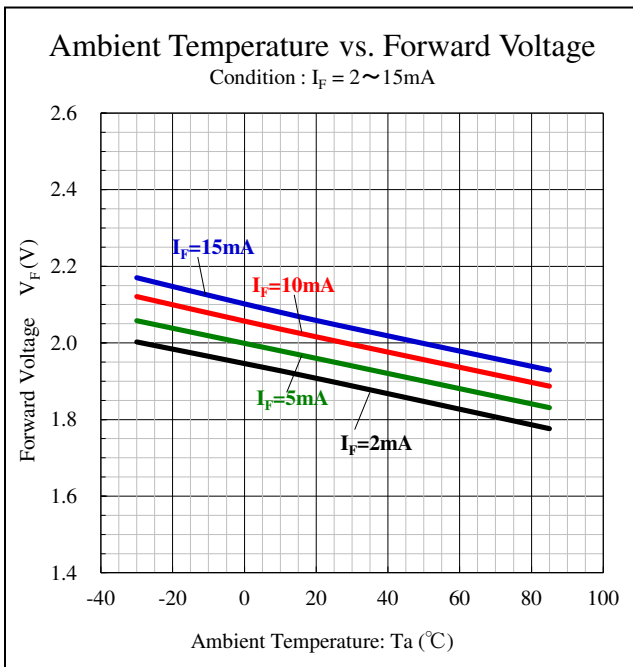
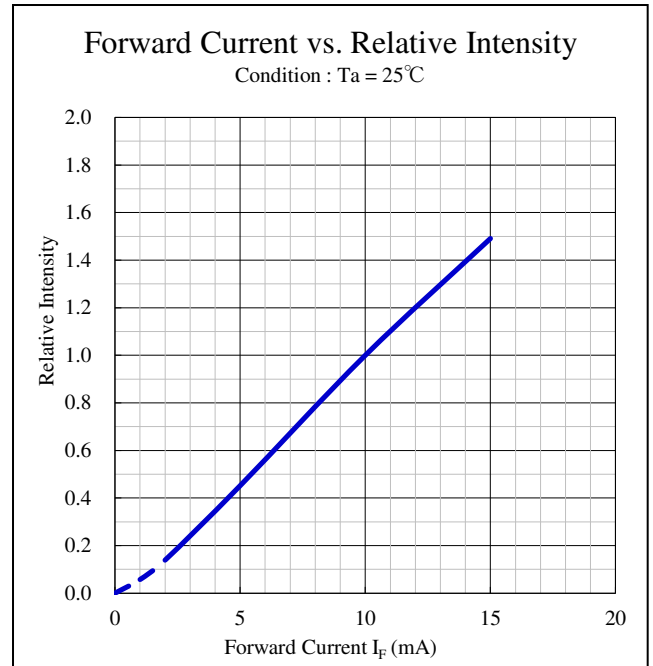
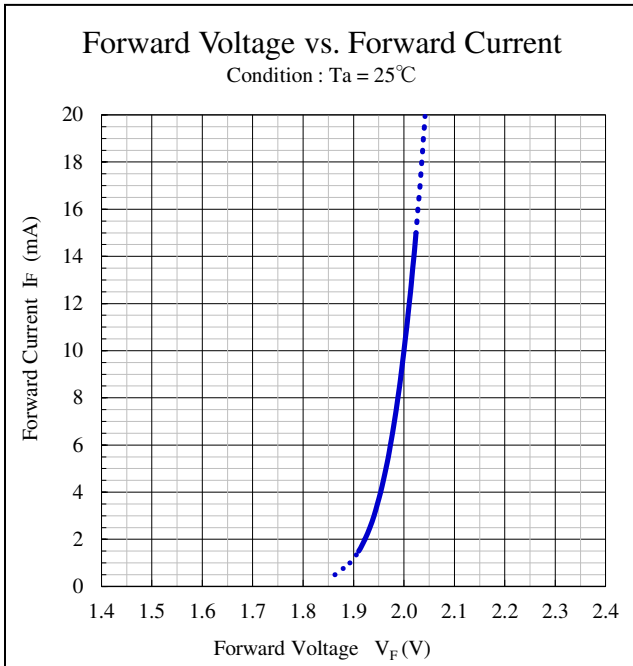

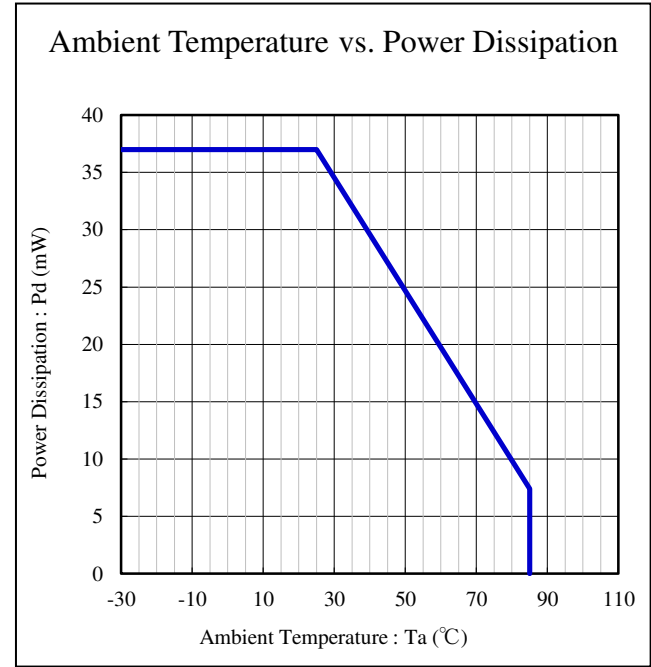
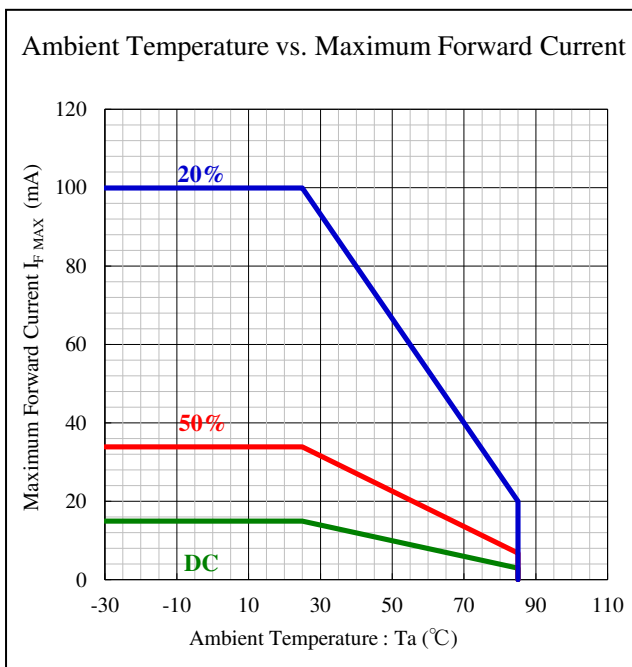
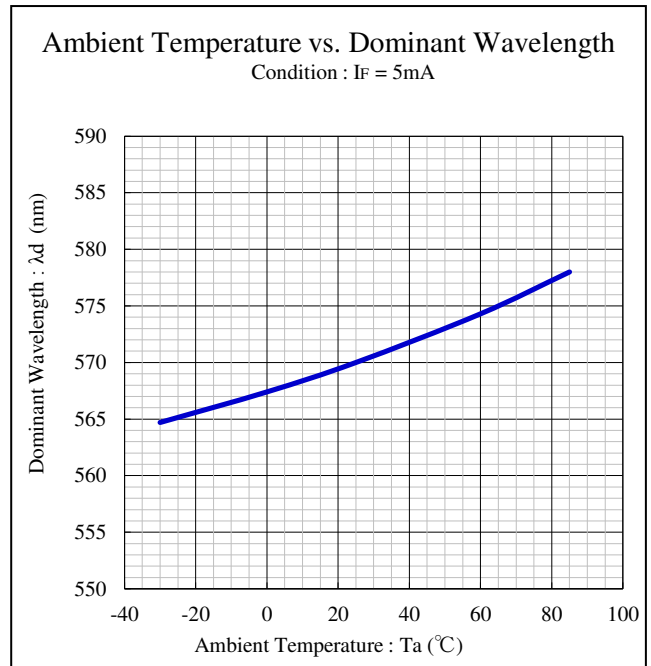
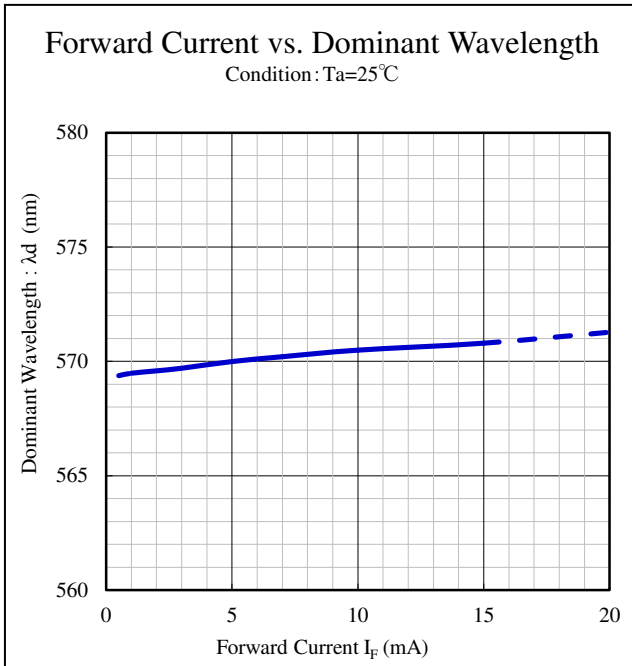

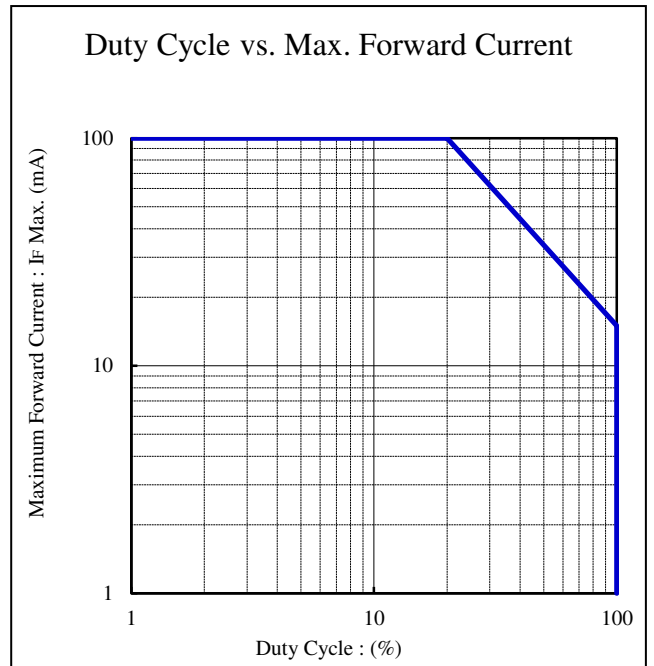
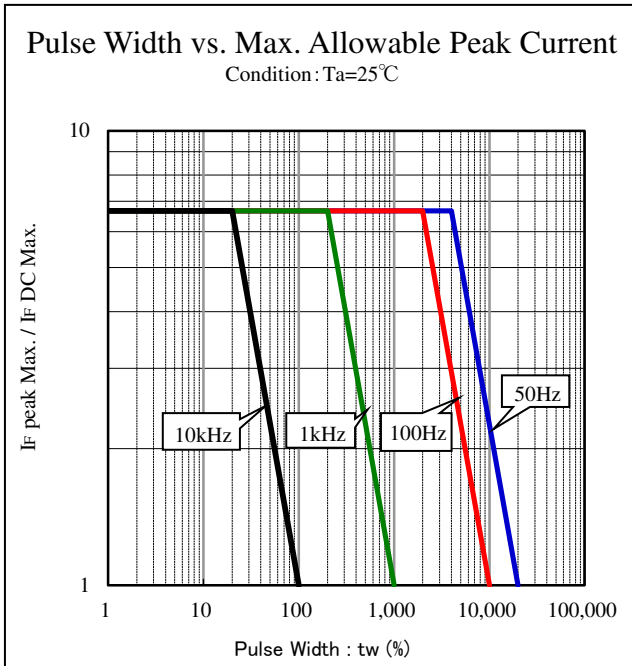

## 1. Soldering precaution

- 1) Avoid dipping the case and mold resin in to the soldering bath.
- 2) The temperature of the case and the mold resin must not become 100 deg. or more.  
Moreover, please make it within 120 sec when you add the temperature that exceeds the storage temperature of the product at even 100 deg. or less.
- 3) The case and the sealing resin are soft, and consider it enough, please solder and after it solders so that neither the shock nor the vibration may join before the normal temperature returns.

## 2. Recommended soldering condition

### 1) Soldering iron

- Temperature at tip of iron : 400 deg. MAX.
- Soldering time : 3 sec MAX.
- Soldering position (※1) : It is a remote lead part from the case bottoms except the flange by 2mm or more.
- The frequency of the dip soldering is up to 2 times.
- Please do the following manual soldering after it cools to the normal temperature after the manual soldering.

#### ※1 Soldering position

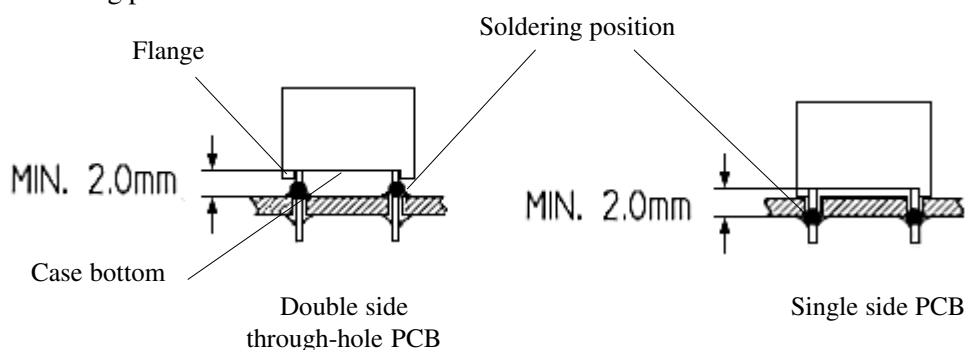

### 2) Dip soldering

- Pre-heating : 60 sec MAX. at 100 deg. MAX.  
(Mold resin temperature. ※2)
- Dip soldering bath-Temperature  
: Non-flow soldering bath 265 deg. MAX.  
: Flow soldering bath 255 deg. MAX
- Dipping time : 5 sec MAX.

#### ※2 Mold resin

The resin filled from the other side of the case is indicated.

- Soldering position : It is a remote lead part from the case bottoms except the flange by 2mm or more.
- The frequency of the dip soldering is up to 2 times.  
This means "2 times of dip" or "1 time of dip + 1 time of repair in solder iron" .
- Please do the operating dip after it cools to the normal temperature after the dip.

### 3) Reflow soldering

Not recommend

## 3.Cleaning

Avoid cleaning the entire LED numeric display.  
 (Only the lead part is assumed to be acceptable.)

- 1) When cleaning it, I will recommend the following. Provided that, it wishes care so as not to adhere about the case because alcohols might violate stamping. Moreover, please refrain a wipe of the case by using alcohols and sufficing. The acetone and thinner might violate the case, and refrain from use, please.

Cleaning agents	Recommended/ Not recommended
Ethyl alcohol	✓ Recommended
Isopropyl alcohol	✓ Recommended
Pure water	✓ Recommended
Acetone	x Not recommended
Thinner	x Not recommended

Notes) •The time of the dip is the normal temperature within at 3 min. .  
 •As for cleaning by the pure water, it is recommended by the condition of 2).

- 2) Please execute forced drying immediately after cleaning after using the pure water (not acceptable city water) and remove the moisture that adheres to the lead completely when the water cleaning is executed.
- 3) When the supersonic wave is used together, the bonding wire in the mold resin might resonate, and the reliability be affected. Therefore, please use it after getting there is no problem in prior in case of your mass production condition in the confirmation.

## 4.Warranty period

**Storage condition: +5~+30 deg, 70% Rh. Max.**

**Warranty period: 6months**

There is a possibility that the lead part where the solder processing was given oxidizes when the above-mentioned period is exceeded, the solderability might deteriorate when the lead part will oxidize.

There is no problem as a product specification because this part is a part that cannot be used as a soldering position in the product specification, and the sulfuration doesn't influence the characteristic though the lead root where the solder processing is not given might be sulfuretted.



## 【 Other Precautions 】

1. Stanley LED Lamps have semiconductor characteristics and are designed to ensure high reliability. However, the performance may vary depending on usage conditions
2. Absolute Maximum Ratings are set to prevent LED lamps from failing due to excess stress( temperature, current, voltage, etc.). Usage conditions must not exceed the ratings for a moment, nor do reach one item of absolute Maximum ratings simultaneously.
3. In order to ensure high reliability from LED Lamps, variable factors that arise in actual usage conditions should be taken into account for designing. ( Derating of TYP., MAX Forward Voltage, etc.)
4. Please insert protective resistors into the circuit in order to stabilize LED operation and to prevent the device from igniting due to excess current.
5. The products are designed to operate without failure in recommended usage conditions. However, please take the necessary precautions to prevent fire, injury, and other damages should any malfunction or failure arise.
6. The products are manufactured to be used for ordinary electronic equipment. Please contact our sales staff beforehand when exceptional quality and reliability are required, and the failure or malfunction of the products might directly jeopardize life or health ( such as for airplanes, aerospace, transport equipment, medical applications, nuclear reactor control systems and so on).
7. When there is a process of supersonic wave welding etc. after mounting the product, there is a possibility of affecting on the reliability of junction part in package (junction part of die bonding and wire bonding). Please make sure there is no problem before using.
8. The performance characteristic of LED numeric display is a value of the guarantee under the measurement condition of the description in the specification. There is a possibility that operation becomes unstable when operating in the low current region (3mA and below). Therefore, After the product selection and the limitation resistance setting, etc. are done, the use of 3mA or more is recommended.
9. Please design the layout of the PCB after it is considered that the adjoining each other LED numeric display doesn't meddle when plurality of is used on the identical PCB.  
Especially, it becomes easy for the PCB to curve easily, and for the product to meddle mutually due to the curve in the dip. The stress hangs in the lead when the product meddles mutually, and the damage of internal might be caused.
10. Avoid excessive stress to lead frames when mounting.  
For example, please do not do the dip where the case is fixed with the dip and the treatment device in the state to assemble the LED numeric display to the PCB for which lead pitch is not suitable.
11. Please do the mounting work at the normal temperature.
12. The clinch of the lead when mounting is not recommended.
13. In regards to a matter of consultation, which is not on these specifications, an exchange is performed after deliberations.
14. Please verify in a real condition, and use it after judging the thing in which trouble is not found in your company when there are differences in the presentation condition on this specification and the condition in the real use.
15. The formal specification sheets shall be valid only by exchange of documents signed by both parties.

# Packaging Specifications

NAG161PH-F

## 1. Internal Packaging

- ① 100pcs product are arranged on tray. (100pcs / 1 tray)
- ② Mirror mat shall be placed on the tray for surface protection of product. Maximum 10 trays are stacked. Empty tray is paved at the bottom of 10 trays.
- ③ Cardboard sheets are placed on the top and the bottom side. Nylon tape is used to seal at 2 places.

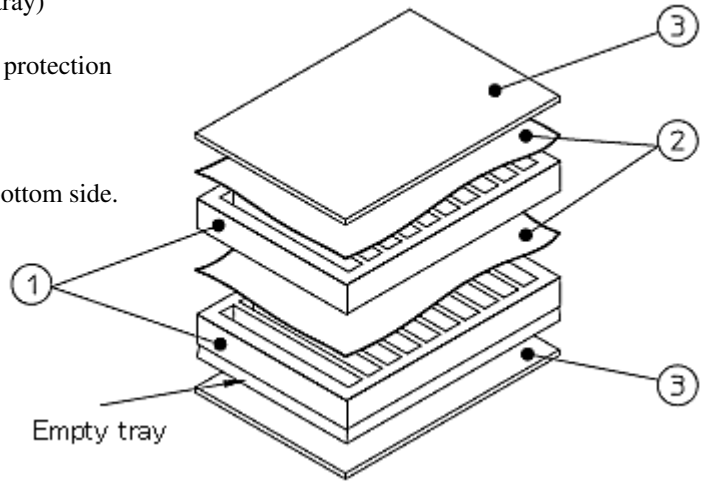

## 2.Inner Carton Box Packaging

- 1 or 2 above internal packing(s) shall be placed into inner carton box ④.
- The size of inner carton box is different depending on the shipping qty.(Number of stacked tray)

- ⑤Product label shall be stuck on the top side of inner carton box.

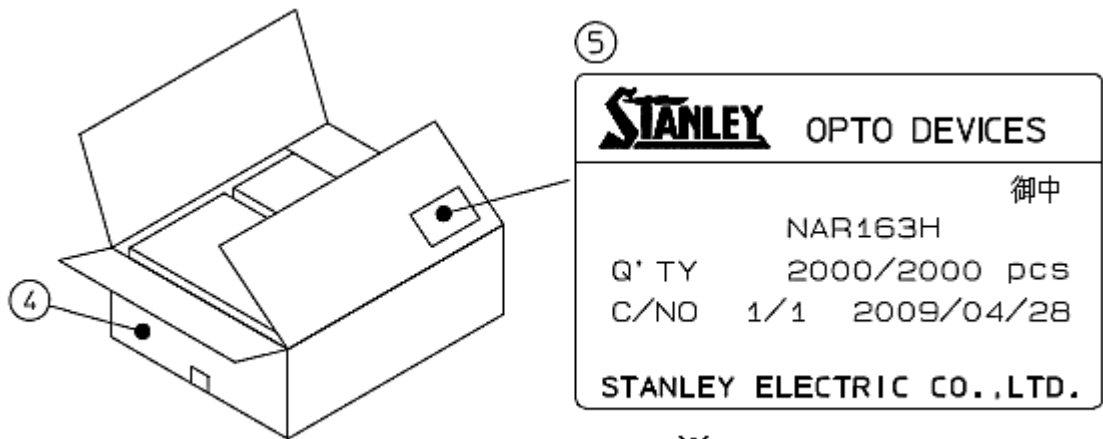

※ Example of label

## 3.Outer Carton Box Packaging

- ④Inner carton box shall be placed into outer carton box ⑥.
- The size of outer carton box is different depending on the shipping qty. and number of inner carton box.

- ⑤Product label shall be stuck on the top side of inner carton box.

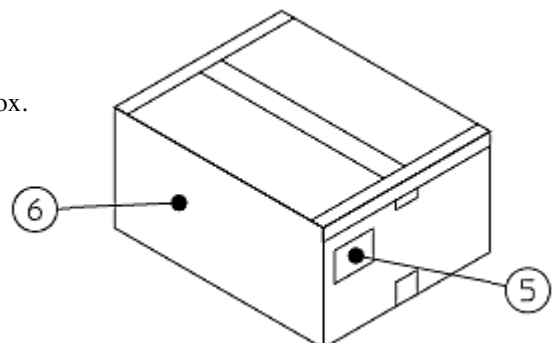

# Lot Number Notational System

# NAG161PH-F

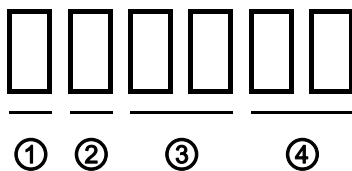

- ① - 1 digit : Cristian era (one digit of end)
- ② - 1 digit : Manufactured month (Jan. ~ Sep.→1 ~ 9 , Oct.→X, Nov.→Y, Dec.→Z )
- ③ - 2 digits : Manufactured da y (01 ~ 31)
- ④ - 2 digits : Production number (2 degits)

This product is in compliance with RoHS・ELV.

Prohibition substance and it's criteria value of RoHS・ELV are as follows.

- RoHS instruction ..... Refer to following (1)~(6).
- ELV instruction ..... Refer to following (1)~(4).

	Substance group name	Criteria value
(1)	Lead and its compounds	1,000ppm MAX
(2)	Cadmium and its compounds	100ppm MAX
(3)	Mercury and its compounds	1,000ppm MAX
(4)	Hexavalent chromium	1,000ppm MAX
(5)	PBB	1,000ppm MAX
(6)	PBDE	1,000ppm MAX

# Reliability Testing Result

NAG161PH-F

TEST ITEM	CONDITIONS	DURATION	FAILURE
Room temperature operating	Ta=25°C, I <sub>F</sub> =15mA	1,000h	0/3
High humidity operating	Ta=60°C, 90%, I <sub>F</sub> =8mA	1,000h	0/3
High temperature operating	Ta=85°C, I <sub>F</sub> =3mA	1,000h	0/3
Low temperature operating	Ta=-30°C, I <sub>F</sub> =15mA	1,000h	0/3
Thermal shock	-30 ~ 85°C(15min. of each)	5 cycles	0/3
Resistance to Dip soldering	Pb free condition (265°C, 5s)	2 times	0/3
Dynamic current drive	Ta=25°C, I <sub>F</sub> =MAX mA, 1ms, 1/5Duty	1,000h	0/3

## Failure Criteria

Items	Symbols	Conditions	Failure criteria
Luminous Intensity	I <sub>v</sub>	10mA	Testing Min. Value < Spec. Min. Value x 0.5
Forward Voltage	V <sub>F</sub>	10mA	Testing Max. Value ≥ Spec. Max. Value x 1.2
Reverse Current	I <sub>R</sub>	5V	Testing Max. Value ≥ Spec. Max. Value x 2.5
Cosmetic Appearance	-	-	Occurrence of notable decoloration, deformation and cracking

## Special Notice to Customers Using the Products and Technical Information Shown in This Data Sheet

- 1) The technical information shown in the data sheets are limited to the typical characteristics and circuit examples of the referenced products. It does not constitute the warranting of industrial property nor the granting of any license.
- 2) For the purpose of product improvement, the specifications, characteristics and technical data described in the data sheets are subject to change without prior notice.  
Therefore it is recommended that the most updated specifications be used in your design.
- 3) When using the products described in the data sheets, please adhere to the Maximum ratings for perating voltage, heat dissipation characteristics, and other precautions for use. We are not responsible for any damage which may occur if these specifications are exceeded.
- 4) The products that have been described to this catalog are manufactured so that they will be used for the electrical instrument of the benchmark (OA equipment, telecommunications equipment, AV machine, home appliance and measuring instrument).  
  
The application of aircrafts, space borne application, transportation equipment, medical equipment and nuclear power control equipment, etc. needs a high reliability and safety, and the breakdown and the wrong operation might influence the life or the human body. Please consult us beforehand if you plan to use our product for the usages of aircrafts, space borne application, transportation equipment, medical equipment and nuclear power control equipment, etc. except OA equipment, telecommunications equipment, AV machine, home appliance and measuring instrument.
- 5) In order to export the products or technologies described in this data sheet which are under the “Foreign Exchange and Foreign Trade Control Law,” it is necessary to first obtain an export permit from the Japanese government.
- 6) No part of this data sheet may be reprinted or reproduced without prior written permission from Stanley Electric Co., Ltd.
- 7) The most updated edition of this data sheet can be obtained from the address below:  
<http://www.stanley-components.com/en/>