

Click [here](#) to ask about the production status of specific part numbers.

MAX6662

12-Bit + Sign Temperature Sensor with SPI-Compatible Serial Interface

General Description

The MAX6662 is a 12-bit + sign temperature sensor combined with a programmable overtemperature alarm and a 3-wire (SPI-compatible) serial interface in a single package. It converts its die temperature into digital values using an internal analog-to-digital converter (ADC). The temperature data is stored in a temperature register as a 13-bit word, which allows 0.0625°C resolution. The temperature data is readable at any time through the serial interface. The operating temperature range is -55°C to +150°C.

The MAX6662 provides two programmable watchdog interrupt outputs. $\overline{\text{ALERT}}$ is used for lower temperature warning functions, while $\overline{\text{OT}}$ is used for higher temperature-critical functions, such as power-supply shutdown. The MAX6662 features a shutdown mode that saves power by disabling everything except the serial interface. The temperature sensor is available in an 8-pin SO package.

Applications

- HVAC
- Refrigeration
- Test Equipment

Features

- 12-Bit + Sign, 0.0625°C Resolution
- Accuracy
 - ±1°C max (+30°C to +50°C)
 - ±1.6°C max (0°C to +70°C)
 - ±2.5°C max (-20°C to +85°C)
 - ±2.5 typ (+150°C)
- Extended Temperature Measurement Range
-55°C to +150°C
- Low Average Supply Current, 125µA (typ)
- Shutdown Mode to Minimize Power Consumption in Portable Applications
- Two Programmable Temperature Fault Outputs
- Switchable Fault Queue to Eliminate False Tripping in Noisy Environments

Ordering Information

PART	TEMP. RANGE	PIN-PACKAGE
MAX6662MSA	-55°C to +150°C	8 SO

Typical Operating Circuit

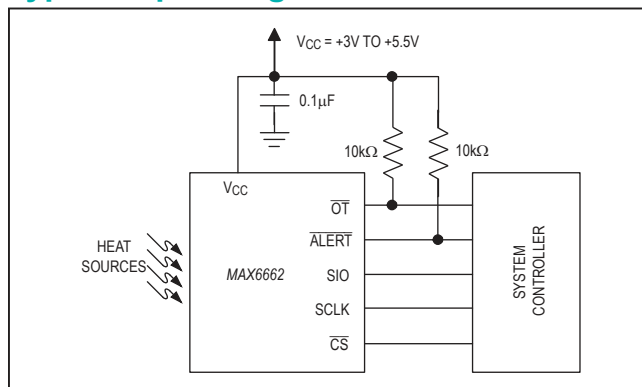

Pin Configuration

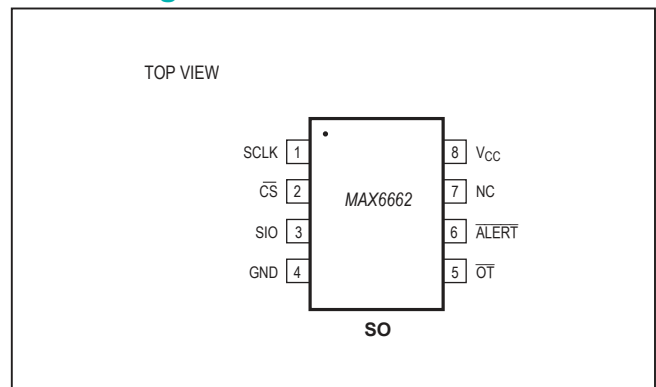

Absolute Maximum Ratings

(All voltages are referenced to GND.)

V _{CC}	-0.3V to +6V
ALERT, OT.....	-0.3V to +6V
SIO, SCLK, CS.....	-0.3V to (V _{CC} + 0.3V)
SIO Current.....	-10mA to +50mA
Continuous Current into Any Pin (except NC).....	10mA

Continuous Power Dissipation (T _A = +70°C) 8-Pin SO (derate 5.9mW/°C above +70°C).....	471mW
Operating Temperature Range (Note 1).....	-55°C to +150°C
Junction Temperature.....	+150°C
Storage Temperature Range.....	-65°C to +150°C
Lead Temperature (soldering, 10s).....	+300°C

Note 1: The MAX6662 is not recommended to operate above +125°C for an extended period of time.

Stresses beyond those listed under “Absolute Maximum Ratings” may cause permanent damage to the device. These are stress ratings only, and functional operation of the device at these or any other conditions beyond those indicated in the operational sections of the specifications is not implied. Exposure to absolute maximum rating conditions for extended periods may affect device reliability.

Electrical Characteristics

(V_{CC} = +3V to +5.5V, T_A = -55°C to +125°C, unless otherwise noted. Typical values are at T_A = +25°C and V_{CC} = +3.3V.)

PARAMETER	SYMBOL	CONDITIONS	MIN	TYP	MAX	UNITS
TEMPERATURE TO DIGITAL-CONVERTER CHARACTERISTICS						
Accuracy		+30°C ≤ T _A ≤ +50°C, V _{CC} = +3.3V	-1.0	±0.4	+1.0	°C
		0°C ≤ T _A ≤ +70°C, V _{CC} = +3.3V	-1.6	±0.7	+1.6	
		-20°C ≤ T _A ≤ +85°C, V _{CC} = +3.3V	-2.5	±1.0	+2.5	
		-40°C ≤ T _A ≤ +100°C, V _{CC} = +3.3V	-3.0	±1.2	+3.0	
		-55°C ≤ T _A ≤ +125°C, V _{CC} = +3.3V	-4.0	±1.5	+4.0	
		T _A ≤ +150°C, V _{CC} = +3.3V		±2.5		
Power-Supply Rejection Ratio	PSRR			0.2	0.5	°C/V
Resolution				0.0625		°C
Supply Voltage Range	V _{CC}		3.0		5.5	V
Average Operating Current		V _{CC} = +5.5V		150		µA
		V _{CC} = +3.0V		125		
Peak Operating Current (Note 2)		V _{CC} = +5.5V		300	600	µA
		V _{CC} = +3.0V		300	500	
Shutdown Supply Current		V _{CC} = +5.5V		8	22	µA
		V _{CC} = +3.0V		4	15	
Power-On-Reset Threshold	V _{POR}			2.0	2.5	V
Power-On-Reset Threshold Hysteresis				90		mV
Conversion Time	t _{CONV}			0.25		s
Temperature Update Frequency				2		Hz
SERIAL INTERFACE (SIO, SCLK, CS, ALERT, OT)						
Input Low Voltage	V _{IL}				0.8	V
Input High Voltage	V _{IH}		0.7 V _{CC}			V
Input/Output Leakage Current	I _{LEAK}	V _{IN} = GND or V _{CC}	-5		+5	µA
Input Capacitance	C _{in}			5		pF
Output Low Sink Current	I _{OL}	ALERT, OT, V _{OL} = 0.6V	3			mA
Output High Voltage	V _{OH}	I _{SIO} = 1.6mA source	V _{CC} - 0.4			V
Output Low Voltage	V _{OL}	I _{SIO} = 1.6mA sink			0.4	V

Electrical Characteristics continued)

($V_{CC} = +3V$ to $+5.5V$, $T_A = -55^{\circ}C$ to $+125^{\circ}C$, unless otherwise noted. Typical values are at $T_A = +25^{\circ}C$ and $V_{CC} = +3.3V$.)

PARAMETER	SYMBOL	CONDITIONS	MIN	TYP	MAX	UNITS
SERIAL INTERFACE TIMING						
Serial Clock Frequency	f_{SCLK}				2.5	MHz
SCLK High Pulse Width	t_{CH}		200			ns
SCLK Low Pulse Width	t_{CL}		200			ns
CS High Pulse Width	t_{CSW}		200			ns
SCLK Fall to Output Data Valid	t_{DO}	$C_{LOAD} = 100pF$			100	ns
CS Fall to SCLK Rise	t_{CSS}		100			ns
CS Rise to Output Disable	t_{TR}	$C_{LOAD} = 100pF$			100	ns
CS to SCLK Hold Time	t_{CSH}		0			ns
SIO to SCLK Setup Time	t_{DS}		100			ns
SIO to SCLK Hold Time	t_{DH}		0			ns
Output Fall Time	t_F			10		ns

Note 2: Peak operating current measured during conversion.

Typical Operating Characteristics

($V_{CC} = +3V$, $T_A = +25^{\circ}C$, unless otherwise noted.)

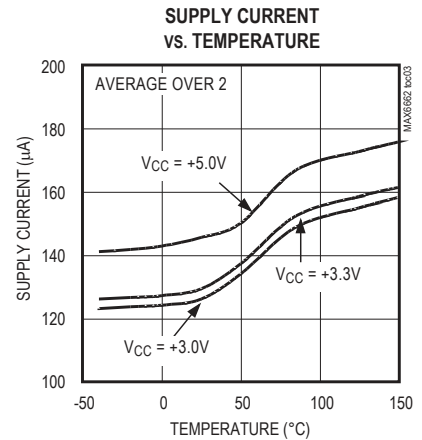
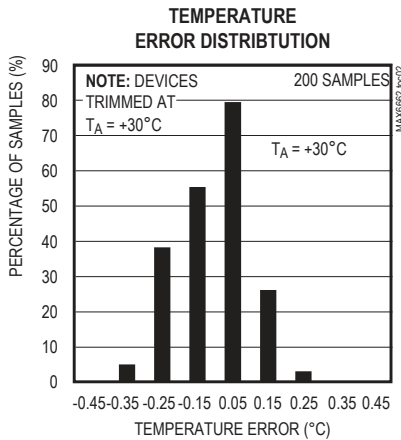
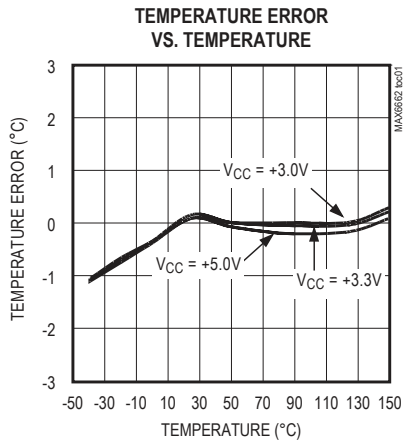

Typical Operating Characteristics (continued)

($V_{CC} = +3V$, $T_A = +25^\circ C$, unless otherwise noted.)

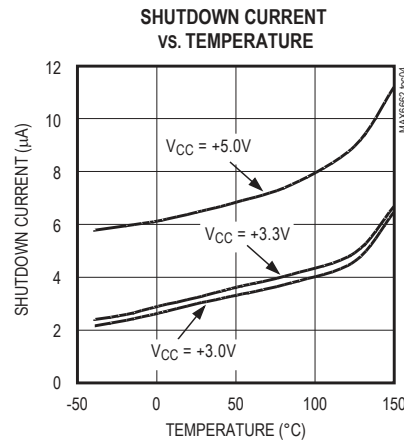

Pin Description

PIN	NAME	FUNCTION
1	SCLK	Serial-Clock Input
2	\overline{CS}	Chip Select Input. Set low to enable the serial interface for data input/output.
3	SIO	Serial-Data Input/Output. Bidirectional data input and output for serial interface.
4	GND	Ground
5	\overline{OT}	Overtemperature Output. Open-drain output requires a pullup resistor to V_{CC} .
6	\overline{ALERT}	Alert Output. Open-drain output requires a pullup resistor to V_{CC} .
7	NC	No Connection. Do not make a connection to this pin.
8	V_{CC}	Supply Voltage Input. Bypass to GND with a 0.1µF capacitor as close to V_{CC} as possible.

Detailed Description

The MAX6662 continuously converts its die temperature into a digital value using its integrated ADC. Temperature data is updated twice a second. The resulting data is readable at any time through the SPI-compatible serial interface.

Figure 1 shows the simplified functional diagram of the MAX6662. Its internal current sources force 100µA and 10µA currents through a diode (diode-connected transistor), while the integrating ADC measures the voltage difference. The difference in voltage corresponds to the die temperature. The result is stored in the temperature register. The control logic unit compares the temperature and the temperature limit settings stored in the registers to determine whether a fault condition has occurred.

Temperature Fault Alert

The \overline{ALERT} is an open-drain active-low (default, also programmable active-high) output used to alert the system to temperature faults. \overline{ALERT} can be programmed to operate in either one of two modes: comparator or interrupt mode.

Interrupt Mode

In the interrupt mode, the MAX6662 \overline{ALERT} pin asserts an alarm for an undertemperature (T_{LOW}) fault, as well as for an overtemperature (T_{HIGH}) fault. Once either fault has occurred, it remains active indefinitely, regardless of condition. \overline{ALERT} is unconditionally deasserted (even if temperature is still out of limits) by reading the temperature register. \overline{ALERT} only asserts again if the temperature crosses the hysteresis, thereby corresponding to the fault (T_{LOW} or T_{HIGH}) that initially set the \overline{ALERT} .

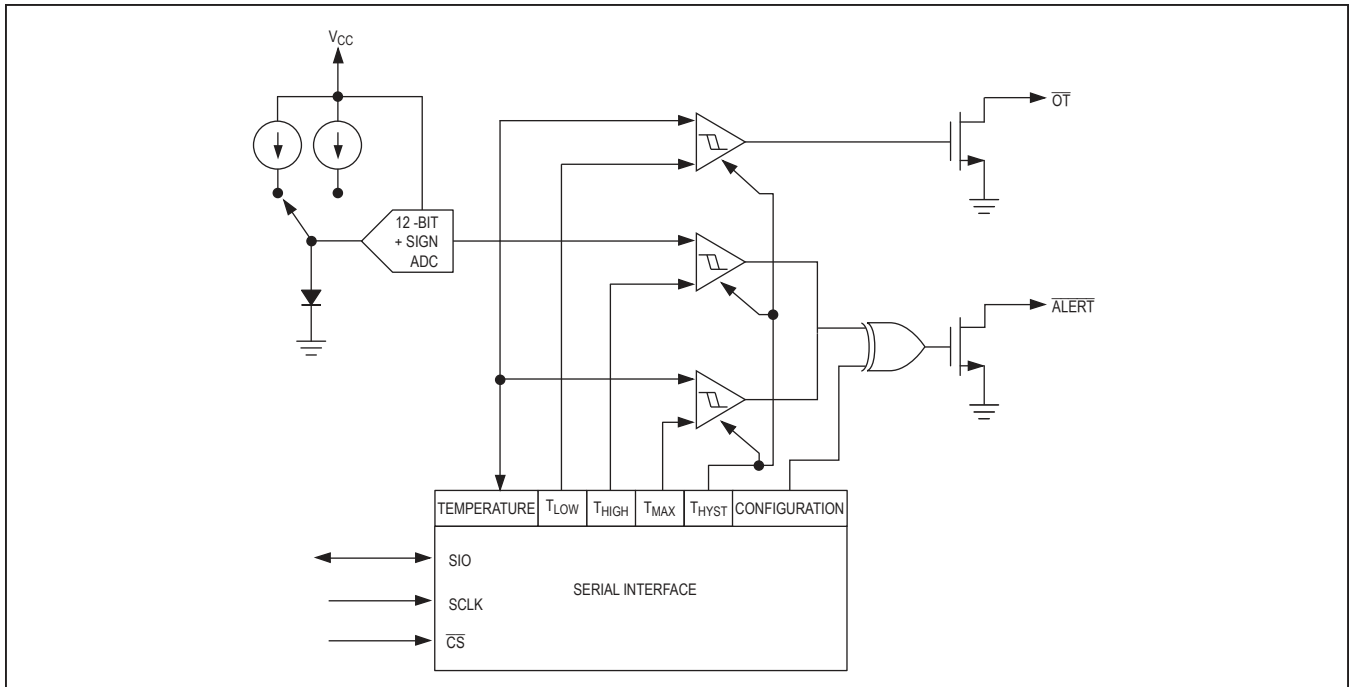

Figure 1. MAX6662 Simplified Functional Diagram

For example: If T_{HIGH} is set to $100^{\circ}C$ and T_{HYST} is set to $20^{\circ}C$, \overline{ALERT} does not assert until temperature exceeds $100^{\circ}C$. If the temperature is then read through the serial interface, \overline{ALERT} deasserts. \overline{ALERT} asserts again when temperature is less than $80^{\circ}C$ (Figure 2).

Comparator Mode

In the comparator mode, \overline{ALERT} is asserted when temperature exceeds the value in the T_{HIGH} register, or is lower than the value in the T_{LOW} register. \overline{ALERT} deasserts when temperature is less than $T_{HIGH} - T_{HYST}$ or greater than $T_{LOW} + T_{HYST}$. Reading the registers does not deassert \overline{ALERT} .

For example: If T_{HIGH} is set to $100^{\circ}C$ and T_{LOW} is set to $80^{\circ}C$, \overline{ALERT} does not assert until temperature exceeds $100^{\circ}C$, or is below $80^{\circ}C$. Then, \overline{ALERT} only deasserts if temperature is less than $T_{HIGH} - T_{HYST}$ or greater than $T_{LOW} + T_{HYST}$.

Overtemperature Alert

\overline{OT} operates only in comparator mode. The \overline{OT} pin is asserted when the temperature exceeds T_{MAX} , and deasserts when the temperature drops below $T_{MAX} - T_{HYST}$. A read operation does not reset \overline{OT} . \overline{OT} is an open-drain active-low (default) output, but can be programmed to active-high.

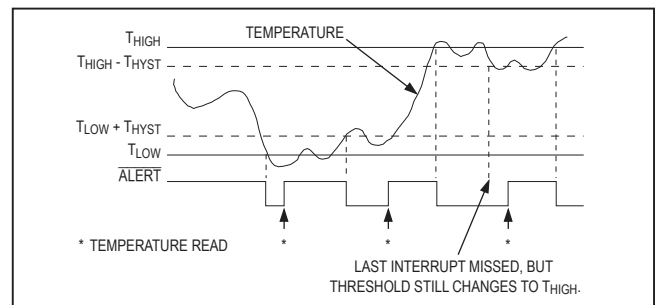

Figure 2. Example of \overline{ALERT} Operation in Interrupt Mode

Temperature Fault Queue

The activation of $\overline{\text{ALERT}}$ and $\overline{\text{OT}}$ is subject to the depth of the fault queue. If the Fault Queue bit in the Configuration register is enabled, $\overline{\text{ALERT}}$ or $\overline{\text{OT}}$ does not assert until four consecutive temperature conversions are at fault.

For example: If T_{HIGH} is set to 100°C, T_{HYST} is set to 20°C, $\overline{\text{ALERT}}$ is set to interrupt mode, and fault queue is enabled, $\overline{\text{ALERT}}$ does not assert until four consecutive conversions exceed 100°C. If the temperature is then read through the serial interface, $\overline{\text{ALERT}}$ deasserts. $\overline{\text{ALERT}}$ asserts again when four consecutive conversions are less than 80°C.

Shutdown Mode

The MAX6662 features a programmable shutdown mode. Set the Shutdown bit in the Configuration register to 1 to shut down. In the shutdown mode, everything is disabled except the power-on reset (POR) and the serial interface. In the shutdown mode, information stored in all registers is retained. The temperature register retains the temperature from the last conversion result.

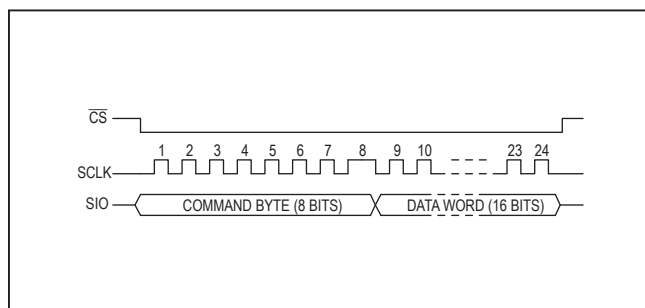

Figure 3. MAX6662 Serial Interface Operation

Serial Interface Protocol

The serial interface consists of three signal lines: chip select ($\overline{\text{CS}}$), bidirectional data line (SIO), and serial clock (SCLK). Only the master (external) drives $\overline{\text{CS}}$ and SCLK. Both the master and the MAX6662 drive SIO. When $\overline{\text{CS}}$ is high, the MAX6662 does not respond to any activity on clock and data lines. When $\overline{\text{CS}}$ goes low, a transaction begins. A valid transaction has 24 clock cycles provided from SCLK after $\overline{\text{CS}}$ goes low—no more and no fewer. Any communication with more or fewer than exactly 24 clocks is ignored. Data is clocked in to the MAX6662 at the rising edge of SCLK when the master is writing. Data is clocked out at the falling edge of SCLK when the master is reading. Both the command byte and data word are clocked in (or out) with the most-significant bit (MSB) bit first. The first eight clock cycles are dedicated to the command byte (1 bit per cycle). This command byte is input to the MAX6662 through the SIO. Sixteen cycles of data follow. The 16 cycles of data are either driven by the master or by the MAX6662, depending on the command byte. If the MAX6662 is driving the SIO, it starts driving at the falling edge of the eighth clock up until the rising edge of CS. Data is available on the falling edge of the eighth clock cycle. Figure 3 depicts a valid serial interface transaction and Figure 4 is the serial interface timing diagram.

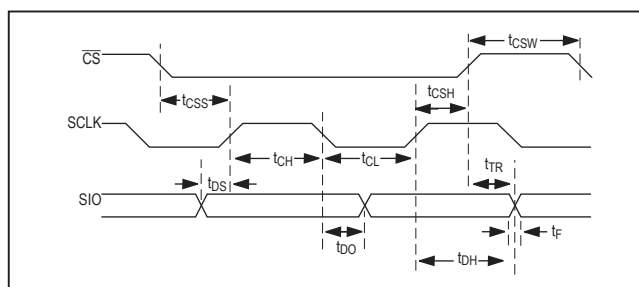

Figure 4. Detailed Serial Interface Timing Diagram

Table 1. Bit Descriptions of the Configuration Register

BIT	POR	DESCRIPTION
15 to 13	0	Reserved. Writing to these bits is ignored.
12	0	Fault Queue bit. Set to 1 to enable queue.
11	0	$\overline{\text{ALERT}}$ polarity bit. Set to 1 for active-high $\overline{\text{ALERT}}$ output. Default is 0 for the $\overline{\text{ALERT}}$ output active-low.
10	0	$\overline{\text{OT}}$ polarity bit. Set to 1 for active-high $\overline{\text{OT}}$ output. Default is 0 for the $\overline{\text{OT}}$ output active-low.
9	0	Interrupt Mode bit. Set to 1 to enable the interrupt mode. Default is 0 for the comparator mode.
8	0	Shutdown bit. Set to 1 to shut down the MAX6662.
7 to 0	0	Reserved. Writing to these bits is ignored.

Table 2. Command Codes for the Temperature Limit Registers

COMMAND	DESCRIPTION
C1h	Temperature register read
C3h	Configuration register read
C5h	T _{HYST} register read
C7h	T _{MAX} register read
C9h	T _{LOW} register read
CBh	T _{HIGH} register read
83h	Configuration register write
85h	T _{HYST} register write
87h	T _{MAX} register write
89h	T _{LOW} register write
8Bh	T _{HIGH} register write

The first bit of the command byte is always high to signify a Start, and the second bit is an R/W bit, high for read and low for write. There are a total of 11 valid commands. The temperature conversion runs continuously and asynchronously from the serial interface. When the Temperature register is read, any conversion in progress is aborted and the data output is from the previous conversion. A new conversion is started each time the serial interface is accessed.

MAX6662 Registers

The MAX6662 has six registers: Temperature, Configuration, T_{HYST}, T_{MAX}, T_{LOW}, and T_{HIGH} registers. They are all 16 bits (Figure 5). The Temperature register is read only; all other registers can be read from or written to.

Temperature Register

The MSB of the Temperature register is the sign bit. The next 12 bits are temperature data. The digital temperature data for the most recent temperature conversion is

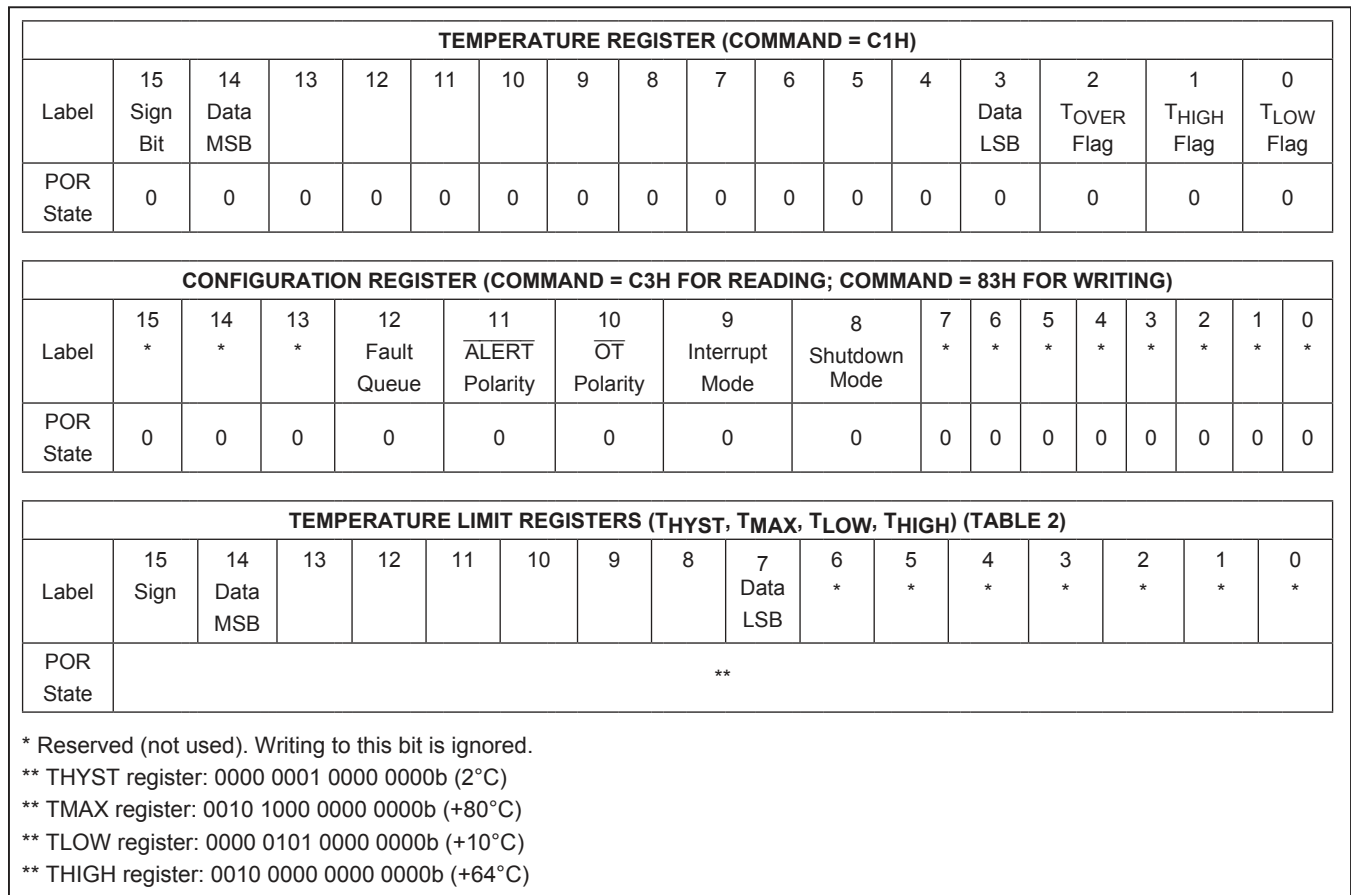

Figure 5. Bit Assignment for the MAX6662 Registers

Table 3. Output Code vs. Temperature

TEMPERATURE (°C)	BINARY CODE
+150.0000	0100 1011 0000 0xxx
+125.0000	0011 1110 1000 0xxx
+25.0000	0000 1100 1000 0xxx
+0.0625	0000 0000 0000 1xxx
0.0000	0000 0000 0000 0xxx
-0.0625	1111 1111 1111 1xxx
-25.0000	1111 0011 1000 0xxx
-55.0000	1110 0100 1000 0xxx

two's-complement format with 1LSB corresponding to 0.0625°C (Table 3). The three least-significant bits (LSBs) are temperature status (flag) bits. The Temperature register is read only. Set the command byte to C1h for reading the Temperature register.

Configuration Register

The Configuration register uses only 5 bits, bits 8 to 12. Table 1 describes its function. Bit 8 is the shut-down bit and should be set to 1 to shut down the entire MAX6662 except the serial interface and POR. Bit 12 is the fault queue bit. When the Fault Queue bit is 1, the $\overline{\text{ALERT}}$ and $\overline{\text{OT}}$ outputs are asserted if four consecutive temperature faults occurred. The Configuration register can be read or written to. Writing to unused bits is ignored. Set the command byte to C3h for reading from this register; set the command byte to 83h for writing to this register.

Temperature-Limit Registers

The High-Temperature (T_{HIGH}), Low-Temperature (T_{LOW}), and the Hysteresis (T_{HYST}) registers set the temperature limit for triggering the $\overline{\text{ALERT}}$ (Figure 1). The Maximum-Temperature (T_{MAX}) and Hysteresis registers set the temperature threshold for the $\overline{\text{OT}}$ output. These temperature-limit registers use the 9MSB bits (8 bits + sign) for setting temperature values in two's complement format with 1°C resolution. The 7LSBs are ignored. These registers can be read or written to. Table 2 shows the command bytes for reading and writing to these registers.

Applications Information

The MAX6662 supply current is typically 125µA when the serial interface is active. When driving high-impedance loads, the devices dissipate negligible power; therefore, the die temperature is essentially the same as the package temperature. The key to accurate temperature monitoring is good thermal contact between the MAX6662 package and the monitored device or circuit. Heat flows in and out of plastic packages primarily through the leads. Short, wide copper traces leading to the temperature monitor ensure that heat transfers quickly and reliably. The rise in die temperature due to self-heating is given by the following formula:

$$\Delta T_J = P_{\text{DISSIPATION}} \times \theta_{JA}$$

where $P_{\text{DISSIPATION}}$ is the power dissipated by the MAX6662, and θ_{JA} is the package's thermal resistance.

The typical thermal resistance is +170°C/W for the 8-pin SO package. To limit the effects of self-heating, minimize the output currents. For example, if the MAX6662 sinks 4mA with the maximum $\overline{\text{ALERT}}$ voltage specification of 0.8V, an additional 3.2mW of power is dissipated within the IC. This corresponds to a 0.54°C rise in the die temperature.

Chip Information

PROCESS: BiCMOS

Package Information\

For the latest package outline information and land patterns (footprints), go to www.maximintegrated.com/packages. Note that a "+", "#", or "-" in the package code indicates RoHS status only. Package drawings may show a different suffix character, but the drawing pertains to the package regardless of RoHS status.

PACKAGE TYPE	PACKAGE CODE	DOCUMENT NO.	LAND PATTERN NO.
8 SO	S8-2	21-0041	90-0096

Revision History

REVISION NUMBER	REVISION DATE	DESCRIPTION	PAGES CHANGED
0	7/01	Initial release	—
1	4/14	Removed automotive reference from <i>Applications</i>	1
2	7/21	Updated Table 3	8

For pricing, delivery, and ordering information, please visit Maxim Integrated's online storefront at <https://www.maximintegrated.com/en/storefront/storefront.html>.

Maxim Integrated cannot assume responsibility for use of any circuitry other than circuitry entirely embodied in a Maxim Integrated product. No circuit patent licenses are implied. Maxim Integrated reserves the right to change the circuitry and specifications without notice at any time. The parametric values (min and max limits) shown in the Electrical Characteristics table are guaranteed. Other parametric values quoted in this data sheet are provided for guidance.