



Product Technical Specification

AirPrime HL8548 and HL8548-G

PRELIMINARY



SIERRA
WIRELESS

4114663
1.0
October 16, 2013

Important Notice

Due to the nature of wireless communications, transmission and reception of data can never be guaranteed. Data may be delayed, corrupted (i.e., have errors) or be totally lost. Although significant delays or losses of data are rare when wireless devices such as the Sierra Wireless modem are used in a normal manner with a well-constructed network, the Sierra Wireless modem should not be used in situations where failure to transmit or receive data could result in damage of any kind to the user or any other party, including but not limited to personal injury, death, or loss of property. Sierra Wireless accepts no responsibility for damages of any kind resulting from delays or errors in data transmitted or received using the Sierra Wireless modem, or for failure of the Sierra Wireless modem to transmit or receive such data.

Safety and Hazards

Do not operate the Sierra Wireless modem in areas where cellular modems are not advised without proper device certifications. These areas include environments where cellular radio can interfere such as explosive atmospheres, medical equipment, or any other equipment which may be susceptible to any form of radio interference. The Sierra Wireless modem can transmit signals that could interfere with this equipment. Do not operate the Sierra Wireless modem in any aircraft, whether the aircraft is on the ground or in flight. In aircraft, the Sierra Wireless modem **MUST BE POWERED OFF**. When operating, the Sierra Wireless modem can transmit signals that could interfere with various onboard systems.

Note: Some airlines may permit the use of cellular phones while the aircraft is on the ground and the door is open. Sierra Wireless modems may be used at this time.

The driver or operator of any vehicle should not operate the Sierra Wireless modem while in control of a vehicle. Doing so will detract from the driver or operator's control and operation of that vehicle. In some states and provinces, operating such communications devices while in control of a vehicle is an offence.

Limitations of Liability

This manual is provided "as is". Sierra Wireless makes no warranties of any kind, either expressed or implied, including any implied warranties of merchantability, fitness for a particular purpose, or noninfringement. The recipient of the manual shall endorse all risks arising from its use.

The information in this manual is subject to change without notice and does not represent a commitment on the part of Sierra Wireless. SIERRA WIRELESS AND ITS AFFILIATES SPECIFICALLY DISCLAIM LIABILITY FOR ANY AND ALL DIRECT, INDIRECT, SPECIAL, GENERAL, INCIDENTAL, CONSEQUENTIAL, PUNITIVE OR EXEMPLARY DAMAGES INCLUDING, BUT NOT LIMITED TO, LOSS OF PROFITS OR REVENUE OR ANTICIPATED PROFITS OR REVENUE ARISING OUT OF THE USE OR INABILITY TO USE ANY SIERRA WIRELESS PRODUCT, EVEN IF SIERRA WIRELESS AND/OR ITS AFFILIATES HAS BEEN ADVISED OF THE POSSIBILITY OF SUCH DAMAGES OR THEY ARE FORESEEABLE OR FOR CLAIMS BY ANY THIRD PARTY.

Notwithstanding the foregoing, in no event shall Sierra Wireless and/or its affiliates aggregate liability arising under or in connection with the Sierra Wireless product, regardless of the number of events, occurrences, or claims giving rise to liability, be in excess of the price paid by the purchaser for the Sierra Wireless product.

Customer understands that Sierra Wireless is not providing cellular or GPS (including A-GPS) services. These services are provided by a third party and should be purchased directly by the Customer.

SPECIFIC DISCLAIMERS OF LIABILITY: CUSTOMER RECOGNIZES AND ACKNOWLEDGES SIERRA WIRELESS IS NOT RESPONSIBLE FOR AND SHALL NOT BE HELD LIABLE FOR ANY DEFECT OR DEFICIENCY OF ANY KIND OF CELLULAR OR GPS (INCLUDING A-GPS) SERVICES.

Patents

This product may contain technology developed by or for Sierra Wireless Inc.

This product includes technology licensed from QUALCOMM®.

This product is manufactured or sold by Sierra Wireless Inc. or its affiliates under one or more patents licensed from InterDigital Group and MMP Portfolio Licensing.

Copyright

© 2013 Sierra Wireless. All rights reserved.

Trademarks

Sierra Wireless®, AirPrime®, AirLink®, AirVantage®, WISMO® and the Sierra Wireless and Open AT logos are registered trademarks of Sierra Wireless, Inc. or one of its subsidiaries.

Watcher® is a registered trademark of NETGEAR, Inc., used under license.

Windows® and Windows Vista® are registered trademarks of Microsoft Corporation.

Macintosh® and Mac OS X® are registered trademarks of Apple Inc., registered in the U.S. and other countries.

QUALCOMM® is a registered trademark of QUALCOMM Incorporated. Used under license.

Other trademarks are the property of their respective owners.

Contact Information

Sales Desk:	Phone:	1-604-232-1488
	Hours:	8:00 AM to 5:00 PM Pacific Time
	Contact:	http://www.sierrawireless.com/sales
Post:	Sierra Wireless 13811 Wireless Way Richmond, BC Canada V6V 3A4	
Technical Support:	support@sierrawireless.com	
RMA Support:	repairs@sierrawireless.com	
Fax:	1-604-231-1109	
Web:	http://www.sierrawireless.com/	

Consult our website for up-to-date product descriptions, documentation, application notes, firmware upgrades, troubleshooting tips, and press releases: www.sierrawireless.com

Document History

Version	Date	Updates
1.0	September 19, 2013	Creation
	October 16, 2013	Updated based on initial internal review

PRELIMINARY



Contents

1. INTRODUCTION	9
1.1. Common Flexible Form Factor (CF3).....	9
1.2. Physical Dimensions	10
1.3. General Features.....	10
1.4. GNSS Features	13
1.5. Architecture	13
1.6. Interfaces.....	14
1.7. Connection Interface	14
1.8. ESD	15
1.9. Environmental & Certifications	15
1.9.1. Environmental Specifications	15
1.9.2. Regulatory	16
1.9.3. RoHS Directive Compliant	17
1.9.4. Disposing of the Product.....	17
1.9.5. References.....	17
2. PAD DEFINITION	18
3. DETAILED INTERFACE SPECIFICATIONS	22
3.1. Power Supply	22
3.2. Power Consumption	22
3.3. VGPIIO	23
3.4. BAT_RTC.....	24
3.5. SIM Interface	24
3.6. USB	25
3.7. Electrical Information for Digital I/O	25
3.8. General Purpose Input/Output (GPIO)	25
3.9. Main Serial Link (UART1).....	26
3.10. POWER ON Signal (PWR_ON)	27
3.11. Reset Signal (RESET).....	27
3.12. ADC	28
3.13. PWM.....	28
3.14. Clock Interface.....	28
3.15. PCM.....	28
3.16. I ² C Interface.....	30
3.17. HSIC	30
3.18. Debug Interfaces	30
3.18.1. Debug Port	30
3.18.2. JTAG	30

3.19.	PPS (HL8548-G Only)	31
3.20.	EXT_LNA_GPS_EN (HL8548-G only)	31
3.21.	RF Interface	31
3.21.1.	RF Connection	31
3.21.2.	RF Performances	32
3.21.3.	TX Burst Indicator (2G_TX_ON)	32
3.22.	GNSS Interface	33
4.	DESIGN GUIDELINES	34
4.1.	Power-Up Sequence	34
4.2.	Module Switch-Off	34
4.3.	Sleep Mode Management	34
4.4.	ESD Guidelines for SIM Card	35
4.5.	Radio Integration	36
5.	X-RAY EXPOSURE	37
6.	FCC/IC LEGAL INFORMATION	38
6.1.	Label	38
6.2.	FCC Regulations	38
6.3.	RF Exposure Information	38
6.4.	IC Regulations	39
7.	TERMS AND ABBREVIATIONS	40



List of Figures

Figure 1.	AirPrime HL8548 and HL8548-G Architecture Overview (TBC)	13
Figure 2.	AirPrime HL8548 and HL8548-G Mechanical Overview	14
Figure 3.	PCM Timing Waveform (TBC).....	29
Figure 4.	2G_TX_ON State during TX Burst	33
Figure 5.	EMC and ESD Components Close to the SIM.....	35
Figure 6.	Serial Resistors for Long SIM Bus Lines.....	35
Figure 7.	Antenna Connection	36
Figure 8.	GNSS Application with Active Antenna.....	36

PRELIMINARY

>> | List of Tables

Table 1.	Supported Bands/Connectivity	9
Table 2.	AirPrime HL8548 and HL8548-G Features	10
Table 3.	GNSS Capabilities	13
Table 4.	ESD Specifications	15
Table 5.	AirPrime HL8548 and HL8548-G Environmental Specifications	15
Table 6.	Regulation Compliance	16
Table 7.	Pad Definition	18
Table 8.	Power Supply	22
Table 9.	Power Consumption	22
Table 10.	VGPIO Electrical Characteristics	23
Table 11.	BAT_RTC Electrical Characteristics	24
Table 12.	Electrical Characteristics of UIM1	24
Table 13.	Digital I/O Electrical Characteristics	25
Table 14.	UART1 Pin Description	26
Table 15.	PWR_ON Electrical Characteristics	27
Table 16.	RESET Electrical Characteristics	27
Table 17.	ADC Electrical Characteristics	28
Table 18.	Digital Audio Interface Electrical Characteristics	29
Table 19.	I ² C Pin Description	30
Table 20.	SW Trace Pin Description	30
Table 21.	JTAG Pin Description	30
Table 22.	PPS Electrical Characteristics	31
Table 23.	RF Connection	31
Table 24.	RF Performance	32
Table 25.	Burst Indicator States	32
Table 26.	TX Burst Characteristics	32
Table 27.	GNSS Interface Specifications	33

1. Introduction

This document is the Product Technical Specification for the AirPrime HL8548 and HL8548-G Embedded Modules. It defines the high level product features and illustrates the interfaces for these features. This document is intended to cover the hardware aspects of the product series, including electrical and mechanical.

The AirPrime HL8548 and HL8548-G belong to the AirPrime HL Series from Essential Connectivity Module family. These are industrial grade Embedded Wireless Modules that provides voice and data connectivity on GPRS, EDGE, WCDMA, HSDPA and HSUPA networks (as listed in Table 1 Supported Bands/Connectivity). On top of this, the HL8548-G also provides GNSS functionality. These modules are designed for the industry and automotive markets and any market with similar quality and life-time support requirements.

The HL8548 and HL8548-G support a large variety of interface like Digital Audio and Dual SIM Single Standby to provide customers with the highest level of flexibility in implementing high-end solutions.

Table 1. Supported Bands/Connectivity

RF Band	Transmit band (Tx)	Receive band (Rx)	Maximum Output Power
UMTS B1	1922 to 1978 MHz	2112 to 2168 MHz	23 dBm (+/- 2dBm) Class 3bis
UMTS B2	1852 to 1908 MHz	1932 to 1988 MHz	23 dBm (+/- 2dBm) Class 3bis
UMTS B5	826 to 847 MHz	871 to 892 MHz	23 dBm (+/- 2dBm) Class 3bis
UMTS B6	832 to 838 MHz	877 to 883 MHz	23 dBm (+/- 2dBm) Class 3bis
UMTS B8	882 to 913 MHz	927 to 958 MHz	23 dBm (+/- 2dBm) Class 3bis
GSM 850	824 to 849 MHz	869 to 894 MHz	2 Watts GSM, GPRS and EDGE
E-GSM 900	880 to 915 MHz	925 to 960 MHz	2 Watts GSM, GPRS and EDGE
DCS 1800	1710 to 1785 MHz	1805 to 1880 MHz	1 Watt GSM, GPRS and EDGE
PCS 1900	1850 to 1910 MHz	1930 to 1990 MHz	1 Watt GSM, GPRS and EDGE
GPS	--	1575.42 ± 20 MHz	--
GLONASS	--	1597.5 to 1605.8 MHz	--

1.1. Common Flexible Form Factor (CF³)

The AirPrime HL8548 and HL8548-G are Common Flexible Form Factor (CF³) modules.

Common Flexible Form Factor (CF³) represents a family of WWAN modules that share the same mechanical dimensions (width and length with varying thicknesses) as well as a standardized footprint but can accommodate multiple radio technologies. The modules will have a “common” form factor across generations of products and for different radio technologies. All modules belonging to this family can be both solder-down as well as connectorized.

The CF³ form factor provides a solution to a set of problems faced commonly in the WWAN module space:

- Accommodate any radio technology and band grouping
- Supports bit-pipe & value add
- Offers electrical and functional compatibility across generations and radio technologies
- Competitive size in 2G and leading edge in 4G
- Solderable as well as socketable
- Enables Configure to Order/Build to Order

1.2. Physical Dimensions

The AirPrime HL8548 and HL8548-G modules are compact, robust, fully shielded modules with the following dimensions:

- Length: 23 mm
- Width: 22 mm
- Thickness: 2.5mm

Note: Dimensions specified above are typical values.

1.3. General Features

The table below summarizes the AirPrime HL8548 and HL8548-G features.

Table 2. AirPrime HL8548 and HL8548-G Features

Feature	Description
Physical	<ul style="list-style-type: none"> • Small form factor (146-pin solderable LGA pad) – 23mm x 22mm x 2.5mm (nominal) • Complete body shielding • RF connection pads – RF primary and GNSS interface • Baseband signals connection
Electrical	Single or double supply voltage (VBATT and VBATT_PA) – 3.2V – 4.5V
RF	<ul style="list-style-type: none"> • Quad-band GSM / GPRS / EDGE (850 MHz, 900 MHz, 1800 MHz, 1900 MHz) • Penta-band UMTS WCDMA FDD (850 MHz(B5/B6), 900MHz(B8), 1900 MHz(B2), 2100MHz(B1)) • GPS (1575.42 MHz), GLONASS (1602MHz)
Audio interface	<ul style="list-style-type: none"> • Digital interface (ONLY) • Supports Enhanced Full Rate (EFR), Full Rate (FR), Half Rate (HR), and both Narrow-Band and Wide-band Adaptive Multirate (AMR-NB and AMR-WB) vocoders • MO and MT calling • Echo cancellation and noise reduction • Emergency calls (112, 110, 911, etc.) • Incoming call notification • DTMF generation
SIM interface	<ul style="list-style-type: none"> • Dual SIM Single Standby with fast network switching capability • 1.8V/3V support • SIM extraction / hot plug detection • SIM/USIM support • Conforms with ETSI UICC Specifications. • Supports SIM application tool kit with proactive SIM commands

Feature	Description
Application interface	<ul style="list-style-type: none"> • NDIS NIC interface support (Windows XP, Windows 7, Windows 8, Windows CE, Linux) • Multiple non-multiplexed USB channel support • Dial-up networking • USB selective suspend to maximize power savings • CMUX multiplexing over UART • AT command interface – 3GPP 27.007 standard, plus proprietary extended AT commands
Protocol Stack	<p>Dual-mode UMTS (WCDMA) / HSDPA / HSUPA / EDGE / GPRS / GSM operation</p> <ul style="list-style-type: none"> • GSM/GPRS/EDGE <ul style="list-style-type: none"> ▪ GPRS/EDGE – Class 33 (296 kbits downlink and 236.8 kbits uplink) ▪ CSD (Circuit-switched data bearers) ▪ Release 4 GERAN Feature Package 1 ▪ SAIC / DARP Phase 2 ▪ Latency Reduction ▪ Repeated FACCH and Repeated SACCH ▪ A-GPS support ▪ GPRS ROHC ▪ Enhanced Operator Name String (EONS) ▪ Enhanced Network Selection (ENS) • WCDMA <ul style="list-style-type: none"> ▪ 3GPP WCDMA FDD Multimode Type II UE Protocol Stack ▪ Configurable for data classes up to 384 kBit/s ▪ Inter-RAT Handover and Cell Reselection ▪ Supports two types of Compressed Mode ▪ Network Assisted Cell Change from UTRAN to GERAN and GERAN to UTRAN ▪ A-GPS support ▪ CSD (Circuit-switched data bearers) over WCDMA (transparent/non transparent up to 64 kBit/s; Support for Video Telephony) • HSDPA (High Speed Downlink Packet Access) <ul style="list-style-type: none"> ▪ Compliant with 3GPP Release 5 ▪ HSDPA Category 8 data rate – 7.2 Mbps (peak rate) ▪ IPv6 support • HSUPA (High Speed Uplink Packet Access) <ul style="list-style-type: none"> ▪ Compliant with 3GPP Release 6 ▪ HSUPA Category 6 data rate - 5.76 Mbps (peak rate) ▪ Robust Header Compression (RoHC) ▪ Fractional DPCH
SMS	<ul style="list-style-type: none"> • SMS MO and MT • CS and PS support • SMS saving to SIM card or ME storage • SMS reading from SIM card or ME storage • SMS sorting • SMS concatenation • SMS Status Report • SMS replacement support • SMS storing rules (support of AT+CNMI, AT+CNMA)

Feature	Description
Supplementary Services	<ul style="list-style-type: none"> • Call Barring • Call Forwarding • Call Hold • Caller ID • Call Waiting • Multi-party service • USSD • Automatic answer
GNSS*	<p>Provides:</p> <ul style="list-style-type: none"> • Standalone GNSS functionality • GPS and GLONASS support • A-GPS features • NMEA support <hr/> <p><i>Note: GNSS specifications are preliminary targets that are subject to change without notice. Actual GNSS functionality is dependent on the firmware version, and on module configuration.</i></p>
Connectivity	<ul style="list-style-type: none"> • Multiple (up to 20) cellular packet data profiles • Sleep mode for minimum idle power draw • Automatic GPRS attach at power-up • GPRS detach • Mobile-originated PDP context activation / deactivation • Support QoS profile <ul style="list-style-type: none"> ▪ Release 97 – Precedence Class, Reliability Class, Delay Class, Peak Throughput, Mean Throughput ▪ Release 99 QoS negotiation – Background, Interactive, and Streaming • Static and Dynamic IP address. The network may assign a fixed IP address or dynamically assign one using DHCP (Dynamic Host Configuration Protocol). • Supports PAP and CHAP authentication protocols • PDP context type (IPv4, IPv6, IPv4v6). IP Packet Data Protocol context • RFC1144 TCP/IP header compression • Interaction with existing GSM services (MO/MT SMS voice calls) while: <ul style="list-style-type: none"> ▪ GPRS is attached, or ▪ In a GPRS data session (class B GPRS suspend / resume procedures)
Environmental	<p>Operating temperature ranges (industrial grade):</p> <ul style="list-style-type: none"> • Class A: -30°C to +70°C • Class B: -40°C to +85°C
RTC	Real Time Clock (RTC) with calendar and alarm
Temperature Sensor	<ul style="list-style-type: none"> • Temperature monitoring • Alarms

* Only available on the AirPrime HL8548-G.

1.4. GNSS Features

The table below summarizes the AirPrime HL8528-G GNSS capabilities.

Table 3. GNSS Capabilities

Feature	Description
GPS	L1 band (CDMA 1575.42 MHz)
GLONASS	L1 Band (FDMA 1602MHz)
SBAS	WAAS, EGNOS, MSAS, GAGAN, QZSS
Channels	52
Antenna	Passive or active antenna support
Assistance data	Server-generated Extended Ephemeris

1.5. Architecture

The figure below presents an overview of the AirPrime HL8548 and HL8548-G internal architecture and external interfaces.

Note: Dotted parts are only supported on the AirPrime HL8548-G.

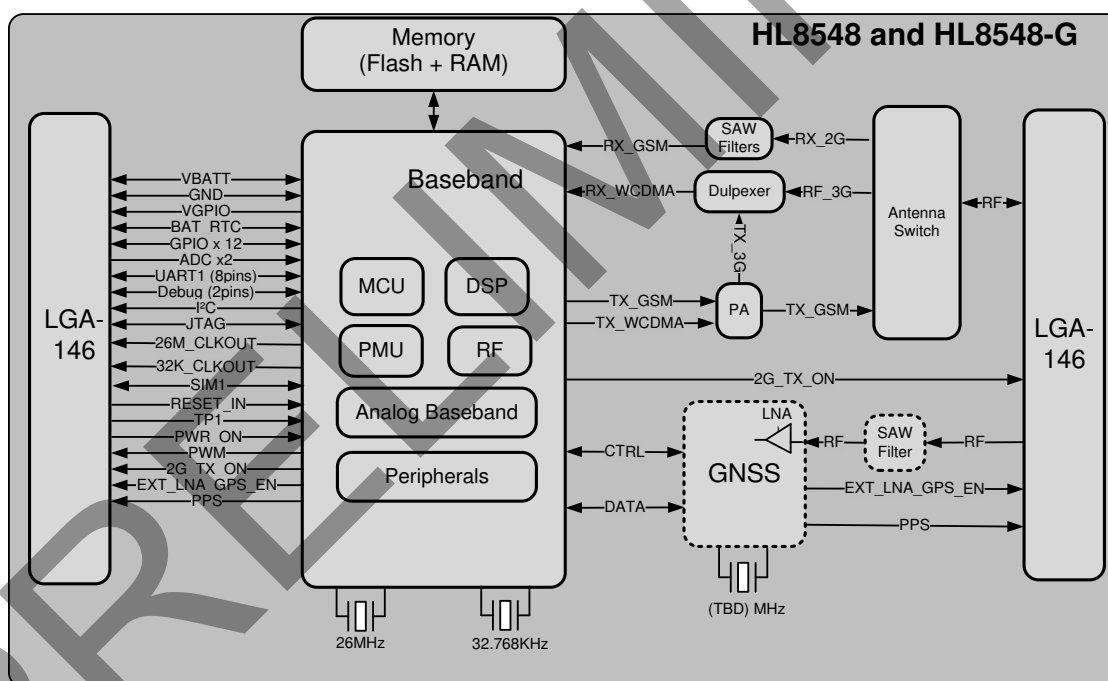

Figure 1. AirPrime HL8548 and HL8548-G Architecture Overview (TBC)

1.6. Interfaces

The AirPrime HL8548 and HL8548-G module provides the following interfaces and peripheral connectivity:

- 1 8-pins UART
- 1 I²C
- 1 HSIC
- Active Low RESET
- USB 2.0
- 1 Backup Battery Interface
- 2 System Clock Out
- Active Low POWER ON
- 1 1.8V/3V SIM
- 1 Digital Audio
- 2 ADC
- 1 JTAG Interface
- 2 PWM
- 12 GPIOs with 4 multiplexes
- 2G TX Burst Indicator
- GSM Antenna

In addition, the AirPrime HL8548-G module provides the following additional interfaces and peripheral connectivity:

- GNSS Antenna
- External GNSS LNA Enable/Disable
- Pulse Per Second

1.7. Connection Interface

The AirPrime HL8548 and HL8548-G module is an LGA form factor device. All electrical and mechanical connections are made through the 146 Land Grid Array (LGA) pads on the bottom side of the PCB.

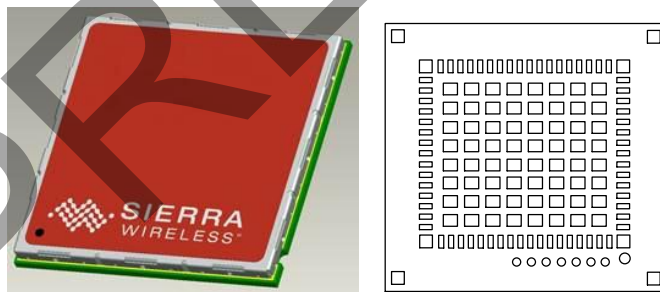

Figure 2. AirPrime HL8548 and HL8548-G Mechanical Overview

The 146 pads have the following distribution:

- 66 inner signal pads, 1x0.5mm, pitch 0.8mm
- 1 reference test point (Ground), 1.0mm diameter
- 7 test point (JTAG), 0.8mm diameter, 1.20mm pitch

- 64 inner ground pads, 1.0x1.0mm, pitch 1.825mm/1.475mm
- 4 inner corner ground pads, 1x1mm
- 4 outer corner ground pads, 1x0.9mm

1.8. ESD

Refer to the following table for ESD Specifications.

Note: Information specified in the following table is preliminary and subject to change.

Table 4. ESD Specifications

Category	Connection	Specification
Operational	RF ports	IEC-61000-4-2 — Level (Electrostatic Discharge Immunity Test)
Non-operational	Host connector interface	Unless otherwise specified: <ul style="list-style-type: none"> • JESD22-A114 +/- 2kV Human Body Model • JESD22-A115 +/- 200V Machine Model • JESD22-C101C +/- 500V Charged Device Model
Signals	SIM connector	ESD protection is highly recommended at the point where the USIM contacts are exposed, and for any other signals that would be subjected to ESD by the user.
	Other host signals	

1.9. Environmental & Certifications

1.9.1. Environmental Specifications

The environmental specification for both operating and storage conditions are defined in the table below.

Table 5. AirPrime HL8548 and HL8548-G Environmental Specifications

Conditions	Range
Operating Class A	-30°C to +70°C
Operating Class B	-40°C to +85°C
Storage	-40°C to +85°C

Class A is defined as the operating temperature ranges that the device:

- Shall exhibit normal function during and after environmental exposure.
- Shall meet the minimum requirements of 3GPP or appropriate wireless standards.

Class B is defined as the operating temperature ranges that the device:

- Shall remain fully functional during and after environmental exposure
- Shall exhibit the ability to establish a voice, SMS or DATA call (emergency call) at all times even when one or more environmental constraint exceeds the specified tolerance.
- Unless otherwise stated, full performance should return to normal after the excessive constraint(s) have been removed.

1.9.2. Regulatory

The AirPrime HL8548 and HL8548-G are both compliant with the following regulations:

- R&TTE directive 1999/5EC
- Japan JRF/JPA
- FCC
- IC

These compliances will be reflected on the AirPrime HL8548 and HL8548-G labels when applicable.

Table 6. Regulation Compliance

Document	Current Version	Title
NAPRD.03	v5.18 or later	Overview of PCS Type certification review board (PTCRB) Mobile Equipment Type Certification and IMEI control
GCF-CC	v3.51.1 or later	GCF Conformance Certification Criteria
TS 51.010-1	V10.0.0 (2012-03)	3rd Generation Partnership Project; Technical Specification Group GSM/EDGE Radio Access Network; Digital cellular telecommunications system (Phase 2+); Mobile Station (MS) conformance specification; Part 1: Conformance specification
TS 51.010-2	V10.0.0 (2012-03)	3rd Generation Partnership Project; Technical Specification Group GSM/EDGE Radio Access Network; Mobile Station (MS) conformance specification; Part 2: Protocol Implementation Conformance Statement (PICS) proforma specification
EN 301511	V9.0.2 (2003-03)	Global System for Mobile Communications (GSM); Harmonized EN for Mobile Stations in the GSM 900 and GSM 1800 Bands Covering Essential Requirements Under Article 3.2 of the R&TTE Directive (1999/5/EC)
EN 301489-1	V1.9.2 (2011-09)	Electromagnetic compatibility and Radio spectrum Matters (ERM); ElectroMagnetic Compatibility (EMC) standard for radio equipment and services; Part 1: Common technical requirements
EN 301489-3	V1.4.1 (2002-08)	Electromagnetic compatibility and Radio spectrum Matters (ERM); ElectroMagnetic Compatibility (EMC) standard for radio equipment and services; Part 3: Specific conditions for Short-Range Devices (SRD) operating on frequencies between 9 kHz and 40 GHz
EN 301489-7	V1.3.1 (2005-11)	Electromagnetic Compatibility and Radio Spectrum Matters (ERM); ElectroMagnetic Compatibility (EMC) Standard for Radio Equipment and Services; Part 7: Specific Conditions for Mobile and Portable Radio and Ancillary Equipment of Digital Cellular Radio Telecommunications Systems (GSM and DCS)
EN 60950-1	NA	IEC 60950-1:2005/A1:2009 EN 60950-1:2006/A11:2009/A1:2010/A12:2011/AC :2011 Information technology equipment – safety- and general requirements
EN 300440-1	v1.6.1 (2012-08)	Electromagnetic compatibility and Radio spectrum Matters (ERM); Short range devices; Radio equipment to be used in the 1 GHz to 40 GHz frequency range; Part 1: Technical characteristics and test methods
EN 300440-2	V1.4.1 (2012-08)	Electromagnetic compatibility and Radio spectrum Matters (ERM); Short range devices; Radio equipment to be used in the 1 GHz to 40 GHz frequency range; Part 2: Harmonized EN under article 3.2 of the R&TTE Directive
FCC Part 15B	NA	Subpart B - Radio frequency devices subpart B – Unintentional Radiators

Document	Current Version	Title
FCC Part 22H	NA	Cellular Radiotelephone Service; Subpart H: Cellular Radiotelephone Service
FCC Part 24E	NA	Personal Communications Service; Subpart E: Broadband PCS.
RSS-132	Issue 2:2005	Cellular telephones employing new technologies operating in the 824-849 MHz and 869-894 MHz bands.
RSS-133	Issue 5:2009	2 GHz personal communications services
AS/ACIF S042.1	2008	Requirements for connection to an air interface of a telecommunications network Part 1; General
AS/ACIF S042.3	2005	Requirements for connection to an air interface of a Telecommunications Network - Part 3: GSM Customer Equipment
AS/NZS 60950.1	2011	Safety of information technology equipment (IEC 60950-1, Ed.2.0: 2005, MOD)
SRRC	NA	State Radio Regulation Center - China Type Approval

1.9.3. RoHS Directive Compliant

The AirPrime HL8548 and HL8548-G module is compliant with RoHS Directive 2011/65/EU which sets limits for the use of certain restricted hazardous substances. This directive states that “from 1st July 2006, new electrical and electronic equipment put on the market does not contain lead, mercury, cadmium, hexavalent chromium, polybrominated biphenyls (PBB) or polybrominated diphenyl ethers (PBDE)”.

1.9.4. Disposing of the Product

This electronic product is subject to the EU Directive 2012/19/EU for Waste Electrical and Electronic Equipment (WEEE). As such, this product must not be disposed of at a municipal waste collection point. Please refer to local regulations for directions on how to dispose of this product in an environmental friendly manner.



1.9.5. References

- [1] AirPrime HL Series Customer Process Guidelines
Reference Number: 4114330
- [2] AirPrime HL6 and HL8 Series AT Commands Interface Guide
Reference Number: 4114680

2. Pad Definition

Table 7. Pad Definition

Pin #	Signal Name	Function	I/O	Active Low/ High	Power Supply Domain	Recommendation for Unused Pins
1	GPIO1 / I2C_CLK	General purpose input/output/I ² C Clock	I/O		1.8V	Left Open
2	UART1_RI	UART1 Ring indicator	O		1.8V	Left Open
3	UART1_RTS	UART1 Request to send	I	L	1.8V	Connect to UART1_CTS
4	UART1_CTS	UART1 Clear to send	O	L	1.8V	Connect to UART1_RTS
5	UART1_TX	UART1 Transmit data	I		1.8V	Mandatory connection
6	UART1_RX	UART1 Receive data	O		1.8V	Mandatory connection
7	UART1_DTR	UART1 Data terminal ready	I	L	1.8V	Connect to UART1_DSR
8	UART1_DCD	UART1 Data carrier detect/	O	L	1.8V	Left Open
9	UART1_DSR	UART1 Data set ready	O	L	1.8V	Connect to UART1_DTR
10	GPIO2	General purpose input/output	I/O		1.8V	Left Open
11	RESET_IN	Input reset signal	I	L	1.8V	Left Open
12	USB_D-	USB Data Negative (Low / Full Speed)	I/O		3.3V	Left Open
		USB Data Negative (High Speed)			0.38V	
13	USB_D+	USB Data Positive (Low / Full Speed)	I/O		3.3V	Left Open
		USB Data Positive (High Speed)			0.38V	
14	HSIC_DATA	High Speed Inter-Chip Data	I/O		1.2V	Left Open
15	HSIC_STRB	High Speed Inter-Chip Strobe	I/O		1.2V	Left Open
16	USB_VBUS	USB VBUS	I		5V	Left Open
17	NC	Not Connected (Reserved for future use)				Left Open
18	NC	Not Connected (Reserved for future use)				Left Open

Pin #	Signal Name	Function	I/O	Active Low/High	Power Supply Domain	Recommendation for Unused Pins
19	NC	Not Connected (Reserved for future use)				Left Open
20	NC	Not Connected (Reserved for future use)				Left Open
21	BAT_RTC	Power supply for RTC backup	I/O		1.8V	Left Open
22	26M_CLKOUT	26MHz System Clock Output	O		1.8V	Left Open
23	32K_CLKOUT	32.768kHz System Clock Output	O		1.8V	Left Open
24	ADC1	Analog to digital conversion	I		1.2V	Left Open (TBC)
25	ADC0	Analog to digital conversion	I		1.2V	Left Open (TBC)
26	UIM1_VCC	1.8V/3V SIM1 Power supply	O		1.8V/3V	Mandatory connection
27	UIM1_CLK	1.8V/3V SIM1 Clock	O		1.8V/3V	Mandatory connection
28	UIM1_DATA	1.8V/3V SIM1 Data	I/O		1.8V/3V	Mandatory connection
29	UIM1_RESET	1.8V/3V SIM1 Reset	O	L	1.8V/3V	Mandatory connection
30	NC	Not Connected (Reserved for future use)				Left Open
31	NC	Not Connected (Reserved for future use)				Left Open
32	NC	Not Connected (Reserved for future use)				Left Open
33	PCM_OUT	PCM data out	O		1.8V	Left Open
34	PCM_IN	PCM data in	I		1.8V	Left Open
35	PCM_SYNC	PCM sync out	I/O		1.8V	Left Open
36	PCM_CLK	PCM clock	I/O		1.8V	Left Open
37	GND	Ground	0V		0V	Mandatory connection
38	RF_GPS	RF GNSS Input				Mandatory connection
39	GND	Ground	0V		0V	Mandatory connection
40	GPIO7	General purpose input/output	I/O		1.8V	Left Open
41	GPIO8	General purpose input/output	I/O		1.8V	Left Open
42	PPS	GNSS Pulse Per Second	O		1.8V	Left Open
43	EXT_LNA_GPS_EN	External GNSS LNA enable	O	H	1.8V	Left Open

Pin #	Signal Name	Function	I/O	Active Low/High	Power Supply Domain	Recommendation for Unused Pins
44	DEBUG_TX	Debug transmit data	I/O		1.8V	Left Open
45	VGPIO	GPIO voltage output	O		1.8V	Left Open
46	GPIO6	General purpose input/output	I/O		1.8V	Left Open
47	TP1	Test Point 1 0 - Download Mode Open - Normal Mode	I	L	1.8V	Left Open
48	GND	Ground			0V	Mandatory connection
49	RF_MAIN	RF GSM Input/output				Mandatory connection
50	GND	Ground			0V	Mandatory connection
51	DEBUG_RX	Debug receive data	I/O		1.8V	Left Open
52	GPIO10	General purpose input/output	I/O		1.8V	Left Open
53	GPIO11	General purpose input/output	I/O		1.8V	Left Open
54	GPIO15	General purpose input/output	I/O		1.8V	Left Open
55	NC1	Reserved for future use				Left Open
56	NC2	Reserved for future use				Left Open
57	PWM1	Pulse Width Modulation	O		1.8V	Left Open
58	PWM2 / GPIO12	Pulse Width Modulation/General purpose input/output	I/O		1.8V	Left Open
59	PWR_ON	Active Low Power On control signal	I	L	1.8V	Mandatory connection
60	2G_TX_ON	2G TX burst indicator	O	H	1.8V	Left Open
61	VBATT_PA	Power supply	I		3.2V (min) 3.7V (typ) 4.5V (max)	Mandatory connection
62	VBATT_PA	Power supply	I		3.2V (min) 3.7V (typ) 4.5V (max)	Mandatory connection
63	VBATT	Power supply	I		3.2V (min) 3.7V (typ) 4.5V (max)	Mandatory connection
64	GPIO3 / UIM1_DET	General purpose input/output/UIM1 Detection	I/O	H	1.8V	Left Open
65	GPIO4	General purpose input/output	I/O	H	1.8V	Left Open

Pin #	Signal Name	Function	I/O	Active Low/ High	Power Supply Domain	Recommendation for Unused Pins
66	GPIO5 / I2C_SDA	General purpose input/output/I ² C Data	I/O		1.8V	Left Open
67-70	GND	Ground	GND		0V	
71 - 166	<i>Note: These pins are not available on the AirPrime HL8548 and HL8548-G modules.</i>					
167-234	GND	Ground	GND		0V	
235	GND	Ground	GND		0V	
236	JTAG_RESET	JTAG RESET	I	L	1.8V	Left Open
237	JTAG_TCK	JTAG Test Clock	I		1.8V	Left Open
238	JTAG_TDO	JTAG Test Data Output	O		1.8V	Left Open
239	JTAG_TMS	JTAG Test Mode Select	I		1.8V	Left Open
240	JTAG_TRST	JTAG Test Reset	I	L	1.8V	Left Open
241	JTAG_TDI	JTAG Test Data Input	I		1.8V	Left Open
242	JTAG_RTCK	JTAG Returned Test Clock	O		1.8V	Left Open

3. Detailed Interface Specifications

Note: If not specified, all electrical values are given for VBATT=3.7V and an operating temperature of 25°C.

For standard applications, VBATT and VBATT_PA must be tied externally to the same power supply. For some specific applications, AirPrime HL8548 and HL8548-G module supports separate VBATT and VBATT_PA connection if requirements below are fulfilled.

3.1. Power Supply

The AirPrime HL8548 and HL8548-G module is supplied through the VBATT signal with the following characteristics.

Table 8. Power Supply

Supply	Minimum	Typical	Maximum
VBATT voltage (V)	3.2 ¹	3.7	4.5
VBATT_PA voltage (V) Full Specification	3.2 ¹	3.7	4.5

1 This value has to be guaranteed during the burst

3.2. Power Consumption

The following table lists the power consumption of the AirPrime HL8548 and HL8548-G at three different temperatures (-40°C, 25°C and 85°C).

Table 9. Power Consumption

Parameter		-40°C	25°C		+85°C
		Typ	Typ	Max	Typ
Off mode			40 µA		
Sleep mode - GSM DRX2 (registered to the network)	GSM900		TBD		
	DCS1800		TBD		
	GSM850		TBD		
	PCS1900		TBD		
Sleep mode - GSM DRX9 (registered to the network)	GSM900		TBD		
	DCS1800		TBD		
	GSM850		TBD		
	PCS1900		TBD		
Sleep mode - WCDMA DRX6 (registered to the network)	Band 1		TBD		
	Band 2		TBD		
	Band 5 / 6		TBD		
	Band 8		TBD		

Parameter		-40°C	25°C		+85°C
		Typ	Typ	Max	Typ
Sleep mode - WCDMA DRX9 (registered to the network)	Band 1		TBD		
	Band 2		TBD		
	Band 5 / 6		TBD		
	Band 8		TBD		
GNSS active mode (@GSM DRX5)			TBD		
WCDMA in communication mode (Voice Call)	Band 1		TBD		
	Band 2		TBD		
	Band 5 / 6		TBD		
	Band 8		TBD		
WCDMA in communication mode (HSDPA)	Band 1		TBD		
	Band 2		TBD		
	Band 5 / 6		TBD		
	Band 8		TBD		
WCDMA in communication mode (HSUPA)	Band 1		TBD		
	Band 2		TBD		
	Band 5 / 6		TBD		
	Band 8		TBD		
GSM in communication mode	GSM900 / GSM850 (PCL=5)		220 mA		
	DCS / PCS (PCL=0)		160 mA		
GSM in communication mode	GSM900 / GSM850 (PCL=5)		220 mA		
	DCS / PCS (PCL=0)		160 mA		
GPRS (2 TX,3 RX)	GSM900 / GSM850 (PCL=5)		360 mA		
	DCS / PCS (PCL=0)		240 mA		
Current consumption during a burst	GSM900 / GSM850		1.50 A	1.8A	
	DCS / PCS		0.8 A	1.0 A	

3.3. VGPIO

The VGPIO output can be used to:

- Pull-up signals such as I/Os
- Supply the digital transistors driving LEDs
- Act as a voltage reference for the ADC interfaces, ADC0 and ADC1

The VGPIO output is available when the AirPrime HL8548 AND HL8548-G module is switched ON.

Table 10. VGPIO Electrical Characteristics

Parameter	Min	Typ	Max	Remarks
Voltage level (V)	1.7	1.8	1.9	Both active mode and sleep mode
Current capability (mA)	-	-	450 (TBC)	Power Management support up to 500mA output.

Parameter	Min	Typ	Max	Remarks
Rise Time(ms)	-	-	1.5	Start-Up time from 0V

3.4. BAT_RTC

The AirPrime HL8548 and HL8548-G module provides an input/output to connect a Real Time Clock power supply.

This pin is used as a back-up power supply for the internal Real Time Clock. The RTC is supported when VBATT is available but a back-up power supply is needed to save date and hour when VBATT is switched off.

If VBATT is available, the back-up battery can be charged by the internal 1.8V power supply regulator.

Table 11. BAT_RTC Electrical Characteristics

Parameter	Minimum	Typical	Maximum	Unit
Input voltage	-	1.8	-	V
Input current consumption	-	2.5 (TBC)	-	μA
Output voltage	-5%	1.8	+5%	V
Max charging current (@VBATT=3.7V)	-	25	-	mA

3.5. SIM Interface

The AirPrime HL8548 and HL8548-G has one physical SIM interface, UIM1, which has optional support for dual SIM application with an external SIM switch. For further information, refer to document [2] AirPrime HL6 and HL8 Series AT Commands Interface Guide for software support.

The UIM1 interface allows control of a 1.8V/3V SIM and is fully compliant with GSM 11.11 recommendations concerning SIM functions.

The four signals used by this interface are as follows:

- UIM1_VCC: power supply
- UIM1_CLK: clock
- UIM1_DATA: I/O port
- UIM1_RST: reset
- UIM1_DET: SIM detection

Table 12. Electrical Characteristics of UIM1

Parameter	Min	Typ	Max	Remarks
UIM1 Interface Voltage (V) (VCC,CLK,IO,RST)	2.7	3.0	3.15	The appropriate output voltage is auto detected and selected by software.
	1.65	1.80	1.95	
UIM1 Detect	1.33	1.80	2.1	High active
UIM1_VCC Current (mA)	-	-	10	Max output current in sleep mode = 3 mA
UIM1_VCC Line Regulation (mV/V)	-	-	50	At Iout_Max
UIM1_VCC Power-up Setting Time (us) from power down	-	10	-	

3.6. USB

The AirPrime HL8548 and HL8548-G have one USB interface.

(Other content TBC)

3.7. Electrical Information for Digital I/O

Table 13 Digital I/O Electrical Characteristics enumerates the electrical characteristics of the following digital interfaces:

- UART
- PCM
- GPIO
- I²C
- JTAG
- RESET
- PWM

Table 13. Digital I/O Electrical Characteristics

Parameter	1.8V Configuration			Remarks
	Min	Typ	Max	
Input Current-High(μ A)	-	-	125	(TBD)
Input Current-Low(μ A)	-	-	125	(TBD)
DC Output Current-High (mA)	-	-	5	Pin driving a "1" with output set at "0"
DC Output Current-Low (mA)	-5	-	-	Pin driving a "0" with output set at "1"
Input Voltage-High(V)	1.33	-	2.1	
Input Voltage-Low(V)	-	-	0.34	
Output Voltage-High(V)	1.5	-	1.9	
Output Voltage-Low(V)	-	-	0.2	

3.8. General Purpose Input/Output (GPIO)

The AirPrime HL8548 and HL8548-G modules provide 12 GPIOs, 4 of which have multiplexes.

Pin Number	Signal Name	Multiplex	I/O	Power Supply Domain
1	GPIO1	I2C_CLK	I/O	1.8V
10	GPIO2		I/O	1.8V
40	GPIO7		I/O	1.8V
41	GPIO8		I/O	1.8V
46	GPIO6		I/O	1.8V
52	GPIO10		I/O	1.8V
53	GPIO11		I/O	1.8V
54	GPIO15		I/O	1.8V

Pin Number	Signal Name	Multiplex	I/O	Power Supply Domain
58	GPIO12	PWM2	I/O	1.8V
64	GPIO3	UIM1_DET	I/O	1.8V
65	GPIO4		I/O	1.8V
66	GPIO5	I2C_SDA	I/O	1.8V

3.9. Main Serial Link (UART1)

The main serial link (UART1) is used for communication between the AirPrime HL8548 and HL8548-G module and a PC or host processor. It consists of a flexible 8-wire serial interface that complies with RS-232 interface.

The supported baud rates of the UART1 are 300, 1200, 2400, 4800, 9600, 19200, 38400, 57600, 115200, 230400, 460800, 500000, 750000, 921600, 1843200, 3000000, 3250000 and 6000000 bit/s.

The signals used by UART1 are as follows:

- TX data (UART1_TX)
- RX data (UART1_RX)
- Request To Send (UART1_RTS)
- Clear To Send (UART1_CTS)
- Data Terminal Ready (UART1_DTR)
- Data Set Ready (UART1_DSR)
- Data Carrier Detect (UART1_DCD)
- Ring Indicator (UART1_RI)

Note: Signal names are according to PC view.

UART1 pin description is summarized in the table below.

Table 14. UART1 Pin Description

Signal Name*	I/O*	Description
UART1_DTR	I (active low)	Prevents the AirPrime HL8548 and HL8548-G from entering sleep mode, switches between data mode and command mode, and wakes the module up.
UART1_DCD	O	Signal data connection in progress
UART1_RX	O	Receive data
UART1_RTS	I	Wakes the module up when KSLEEP=1 is used
UART1_TX	I	Transmit data
UART1_CTS	O	AirPrime HL8548 and HL8548-G is ready to receive AT commands
UART1_RI	O	Signal incoming calls (voice and data), SMS, etc.
UART1_DSR	O	Signal UART interface is ON

* According to PC view.

3.10. POWER ON Signal (PWR_ON)

A low level signal has to be provided to switch the AirPrime HL8548 and HL8548-G module ON.

It is internally connected to the permanent 1.8V supply regulator inside the HL8548 and HL8548-G via a pull-up resistor. Once VBAT is supplied to the HL8548 and HL8548-G module, this 1.8V supply regulator will be enabled and so the PWR_ON signal is by default at high level.

The PWR_ON signal's characteristics are listed in the table below.

Table 15. PWR_ON Electrical Characteristics

Parameter	Min	Typical	Max
Input Voltage-Low (V)		-	0.51
Input Voltage-High (V)	1.33	-	2.2
Power-up period (ms) from PWR_ON falling edge	(TBD)	-	-

Note: As PWR_ON is internally pulled up with 200kΩ, a simple open collector or open drain transistor must be used for ignition.

VGPIO is an output from the module that can be used to check if the module is active.

- When VGPIO = 0V, the module is OFF.
- When VGPIO = 1.8V, the module is ON (it can be in idle, communication or sleep mode)

Note: PWR_ON cannot be used to power the module off. To power the module off, use AT command AT+CFUN=0.

3.11. Reset Signal (RESET)

To reset the module, a low level pulse must be sent on the RESET pin for 10ms. This action will immediately restart the AirPrime HL8548 and HL8548-G module. It is therefore useless to perform a new ignition sequence (PWR_ON) after.

As RESET is internally pulled up, a simple open collector or open drain transistor can be used to control it.

The RESET signal will reset the registers of the CPU and reset the RAM memory as well, with the PWR_ON signal at low level.

Note: As RESET is referenced to the VGPIO domain (internally to the module), it is impossible to reset before the module starts or to try to use RESET as a way to start the module.

Another more costly solution would be to use MOS transistor to switch the power supply off and restart the power up procedure using the PWR_ON input line.

Table 16. RESET Electrical Characteristics

Parameter	Minimum	Typical	Maximum
Input Voltage-Low(V)		-	0.51
Input Voltage-High(V)	1.33	-	2.2
Power up Period (ms) from RESET falling edge	(TBD)	-	-

3.12. ADC

Two Analog to Digital Converter inputs, ADC0 and ADC1, are provided by the AirPrime HL8548 and HL8548-G module. These converters are 10-bit resolution ADCs ranging from 0 to 1.2V.

Typically, the ADCx input can be used to monitor external temperature. This is very useful for monitoring the application temperature and can be used as an indicator to safely power the application OFF in case of overheating (for Li-Ion batteries).

Both ADCs have the characteristics listed in the table below.

Table 17. ADC Electrical Characteristics

Parameter	Min	Typ	Max	Remarks
ADC Resolution (bits)	-	10	-	
Input Voltage Range (V)	0	-	1.2	General purpose input
Update rate per channel (kHz)	-	-	200 (TBC)	
Integral Nonlinearity (bits)	-	-	±2	LSB
Offset Error (bits)	-	-	±1	LSB
Gain	849	853	858	
Input Resistance (MΩ)	1	-	-	
Input Capacitance (pF)	-	1	-	

3.13. PWM

The AirPrime HL8548 and HL8548-G modules provide two PWM signal.

(Other content TBC)

3.14. Clock Interface

The AirPrime HL8548 and HL8548-G modules support a clock interface.

(Other content TBC)

3.15. PCM

The Digital Audio (PCM) Interface allows connectivity with standard audio peripherals. It can be used, for example, to connect an external audio codec.

The programmability of this interface allows addressing a large range of audio peripherals.

The signals used by the Digital Audio Interface are as follows:

- PCM_SYNC: The frame synchronization signal delivers an 8kHz frequency pulse that synchronizes the frame data in and the frame data out.
- PCM_CLK: The frame bit clock signal controls data transfer with the audio peripheral.
- PCM_OUT: The frame “data out” relies on the selected configuration mode.
- PCM_IN: The frame “data in” relies on the selected configuration mode.

The PCM interface is a high speed full duplex interface that can be used to send and receive digital audio data to external audio ICs. The Digital Audio Interface also features the following:

- PCM master and slave
- 16 bits data word length
- MSB or LSB first
- Rising or falling sampling clock edge
- Configurable PCM bit clock rate up to 1MHz
- Long frame sync

Refer to the following table for the electrical characteristics of the digital audio interface.

Table 18. Digital Audio Interface Electrical Characteristics

Signal	Description	Minimum	Typical	Maximum	Unit
Tsync_low + Tsync_high	PCM-SYNC period		125		μs
Tsync_low	PCM-SYNC low time		124		μs
Tsync_high	PCM-SYNC high time		1		μs
TCLK-cycle	PCM-CLK period		1000		ns
TIN-setup	PCM-IN setup time	(TBD)			ns
TIN-hold	PCM-IN hold time	(TBD)			ns
TOUT-delay	PCM-OUT delay time			(TBD)	ns
TSYNC-delay	PCM-SYNC output delay	(TBD)		(TBD)	ns

The following figure shows the PCM timing waveform.

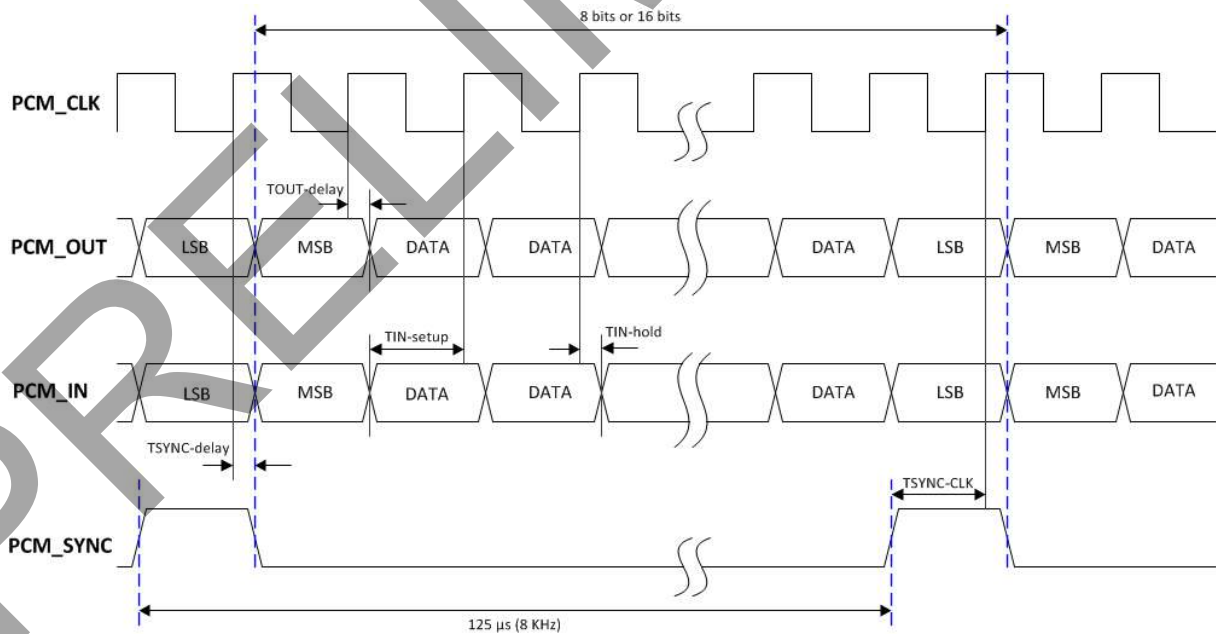

Figure 3. PCM Timing Waveform (TBC)

3.16. I²C Interface

NMEA frames can be output from USB, UART1 or through a dedicated serial port (I²C).

Table 19. I²C Pin Description

Pin Number	Signal Name	Function
1	I2C_CLK	I ² C Clock
66	I2C_SDA	I ² C Data

Note: I²C pins are multiplexed with GPIO features.

3.17. HSIC

The AirPrime HL8548 and HL8548-G embedded modules provide a standard high-speed inter-chip (HSIC) interface as slave.

(Other content TBC)

3.18. Debug Interfaces

The AirPrime HL8548 and HL8548-G module provides 2 interfaces for a powerful debug system.

3.18.1. Debug Port

The AirPrime HL8548 and HL8548-G provides a 2-wire debug port interface, providing real-time instruction and data trace of the Modem Core.

Table 20. SW Trace Pin Description

Pin Number	Signal Name	Function
44	DEBUG_TX	Debug Transmit Data
51	DEBUG_RX	Debug Receive Data

Note: It is strongly recommended to provide access through Test Points to this interface.

3.18.2. JTAG

The JTAG interface provides debug access to the core of the HL8548 and HL8548-G. These JTAG signals are accessible through solder-able test points.

Table 21. JTAG Pin Description

Pin Number	Signal Name	Function
47	TP1	Test Point 1
236	JTAG_RESET	JTAG RESET
237	JTAG_TCK	JTAG Test Clock

Pin Number	Signal Name	Function
238	JTAG_TDO	JTAG Test Data Output
239	JTAG_TMS	JTAG Test Mode Select
240	JTAG_TRST	JTAG Test Reset
241	JTAG_TDI	JTAG Test Data Input
242	JTAG_RTCK	JTAG Returned Test Clock

Note: It is recommended to provide access through Test Points to this interface the JTAG pins (for Failure Analysis debugging).

All signals listed in table above shall be outputs on the customer board to allow JTAG debugging.

3.19. PPS (HL8548-G Only)

The PPS signal is an output pulse related to GNSS receiver time.

Table 22. PPS Electrical Characteristics

Parameter	Min	Typ	Max	Test Conditions
Frequency		1Hz		
Pulse width		TBD		
Synchronization to GNSS time			1 μ s	

Note: This output is available only when GNSS is in tracking mode.

3.20. EXT_LNA_GPS_EN (HL8548-G only)

EXT_LNA_GPS_EN ON indicates whether the GNSS receiver is active and can be used to enable an external LNA (or active antenna), especially during GNSS low power mode.

3.21. RF Interface

The GSM RF interface of the HL8548 and HL8548-G module allows the transmission of RF signals. This interface has a 50 Ω nominal impedance.

3.21.1. RF Connection

A 50 Ω stripline can be used to connect to standard RF connectors such as SMA, UFL, etc. for antenna connection.

Table 23. RF Connection

RF Signal	Impedance	VSWR Rx (max)	VSWR Tx (max)
RF_MAIN	50 Ω	TBD	TBD

3.21.2. RF Performances

RF performances are compliant with the ETSI recommendation GSM 05.05.

Table 24. RF Performance

Frequency Band	Typical Sensitivity (dBm)	Maximum Sensitivity (dBm)
GSM850/EGSM	-109(TBC)	-107(TBC)
DCS/PCS	-108(TBC)	-106(TBC)
UMTS B1	-106(TBC)	-104(TBC)
UMTS B2	-109(TBC)	-104(TBC)
UMTS B5/6	-109(TBC)	-104(TBC)
UMTS B8	-108(TBC)	-104(TBC)

3.21.3. TX Burst Indicator (2G_TX_ON)

The AirPrime HL8548 and HL8548-G module provides a signal, 2G_TX_ON, for TX Burst indication. The 2G_TX_ON is a 1.8V signal and its status signal depends on the module transmitter state.

Refer to the following table for the status of the 2G_TX_ON signal depending on the embedded module's state.

Table 25. Burst Indicator States

Embedded Module State	2G_TX_ON
During TX burst	High
No TX	Low

During TX burst, there is a higher current drain from the VBATT_PA power supply which causes a voltage drop. This voltage drop from VBATT_PA is a good indication of a high current drain situation during TX burst.

The blinking frequency is about 217Hz.

The output logic high duration, $T_{duration}$, depends on the number of TX slots and is computed as follows:

$$T_{duration} = T_{advance} + (0.577ms \times \text{number of TX slots}) + T_{delay}$$

Table 26. TX Burst Characteristics

Parameter	Minimum	Typical	Maximum
Tadvance	30μs		
Tdelay	5μs		

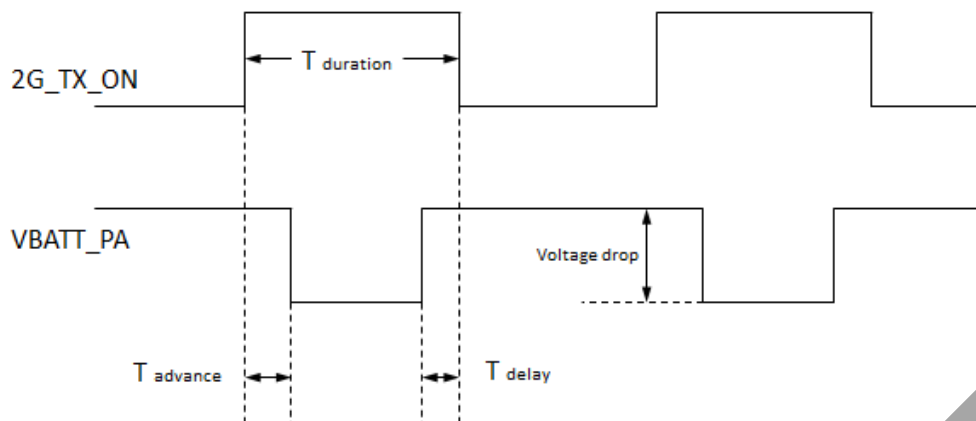

Figure 4. 2G_TX_ON State during TX Burst

3.22. GNSS Interface

The AirPrime HL8548-G embeds an integrated and high-sensitivity Global Navigation Satellite System (GNSS) solution through pin 38, RF_GPS.

Based on SiRFstarV™ from CSR, the HL8548-G combines GPS and GLONASS reception to improve navigation capabilities and position accuracy in obstructed view environments such as urban canyons. GNSS performances are improved by CW jammer and interference mitigation system and automated hardware blanking capabilities.

In addition, it supports Downloaded Extended Ephemeris Assisted-GNSS, for enhanced time to acquire or reacquire a fix.

The operation of GNSS is offloaded to a GNSS standalone solution to guaranty the modem resources availability for the best performances.

The GNSS implementation supports GPS L1 signal (1575.42 ± 20 MHz) and GLONASS L1 FDMA signals for frequency -7 to 6 (1597.5 – 1605.8 MHz), with 50Ω connection on RF_GPS pad.

Table 27. GNSS Interface Specifications

Parameter		Value
Sensitivity	Cold start	-148dBm
	Hot start	-158dBm
	Navigation	-162dBm
Horizontal Position Accuracy		TBD
Standalone Time To First Fix (TTFF)	Hot start	TBD
	Warm start	TBD
	Cold start	TBD

>> 4. Design Guidelines

4.1. Power-Up Sequence

Apply a LOW level logic to the PWR_ON pin (pin 59); within approximately 25ms, the VGPI0 will appear to be at 1.8V. Either a USB or UART1 interface could be used to send AT commands.

4.2. Module Switch-Off

AT command AT+CFUN=0 enables the user to properly switch the AirPrime HL8548 and HL8548-G module off.

If required, the module can be switched off by controlling the power supply. This can be used, for example, when the system freezes and no reset line is connected to the AirPrime HL8548 and HL8548-G module. In this case, the only way to get control over the module back is to switch off the power line.

4.3. Sleep Mode Management

(TBC)

AT command AT+KSLEEP enables sleep mode configuration.

AT+KSLEEP=0:

- The AirPrime HL8548 and HL8548-G is active when the DTR signal is active (low electrical level).
- When DTR is deactivated (high electrical level), the AirPrime HL8548 and HL8548-G enters sleep mode after a while.
- On DTR activation (low electrical level), the AirPrime HL8548 and HL8548-G wakes up.

AT+KSLEEP=1:

- The AirPrime HL8548 and HL8548-G determines when it enters sleep mode (when no more tasks are running).
- "0x00" characters on the serial link wakes the AirPrime HL8548 and HL8548-G up.

AT+KSLEEP=2:

- The AirPrime HL8548 and HL8548-G never enters sleep mode.

In sleep mode, the module reduces its power consumption and remains waiting for the wake up signals either from the network (i.e. read paging block depending on the DRX value of the network) or the operating system (i.e. timers wake up, timers activated) or the host controller (i.e. character on serial link or DTR signal).

4.4. ESD Guidelines for SIM Card

Decoupling capacitors must be added on UIM1_CLK, UIM1_RST, UIM1_VCC, UIM1_DATA and UIM_DET signals as close as possible to the SIM card connector to avoid EMC issues and to pass the SIM card type approvals, according to the drawings below.

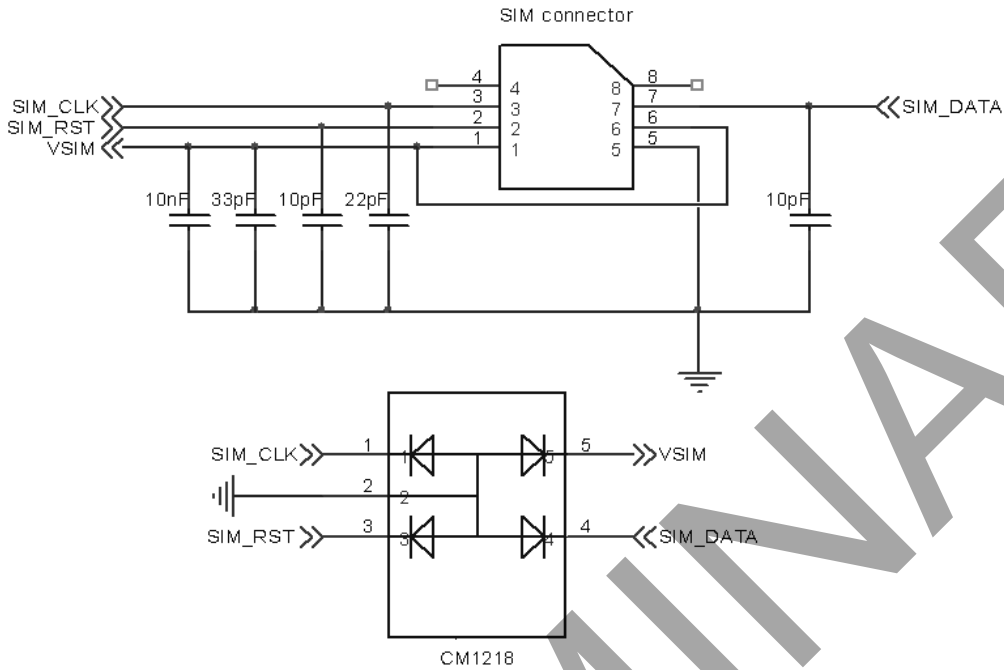

Figure 5. EMC and ESD Components Close to the SIM

In the case of long SIM bus lines over 10cm, it is recommended to also use serial resistors to avoid electrical overshoots on SIM bus signals. Use 56Ω for the clock line and 10Ω for the reset and data lines.

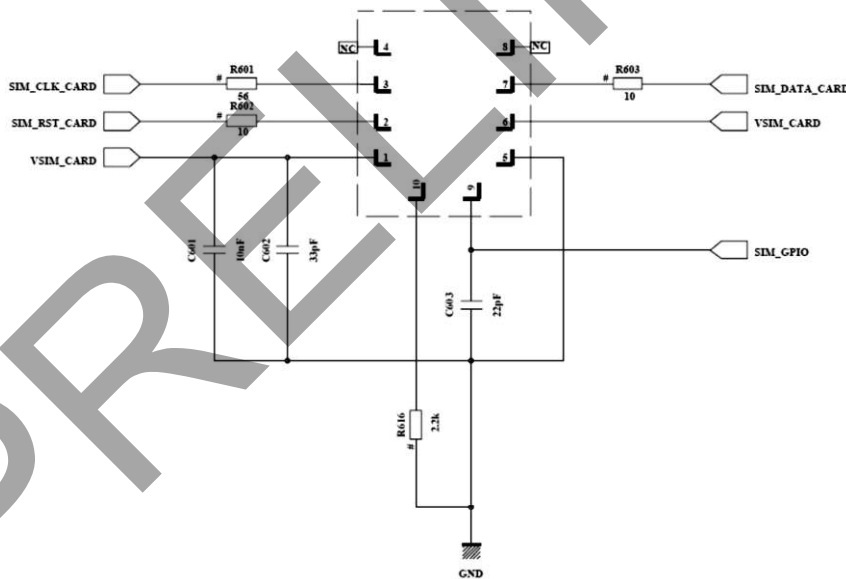

Figure 6. Serial Resistors for Long SIM Bus Lines

4.5. Radio Integration

The AirPrime HL8548 and HL8548-G is equipped with external antennas. A 50Ω line matching circuit between the module, the customer's board and the RF antennas is required, for GSM and GNSS feed path, as shown in the example below.

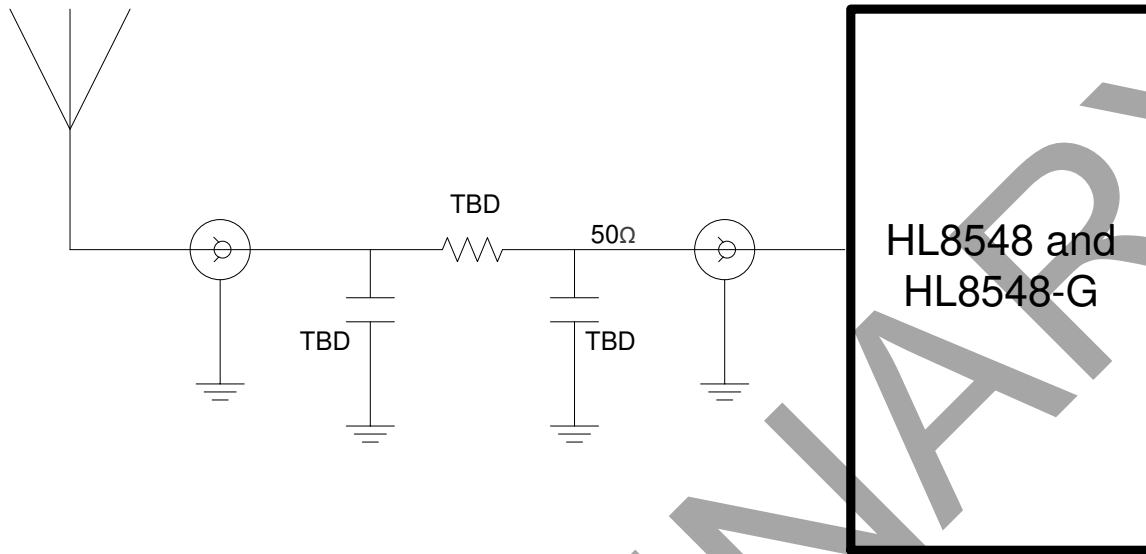

Figure 7. Antenna Connection

The AirPrime HL8548-G also embeds a GPS/GLONASS receiver inside the module. The figure below is an active antenna use case.

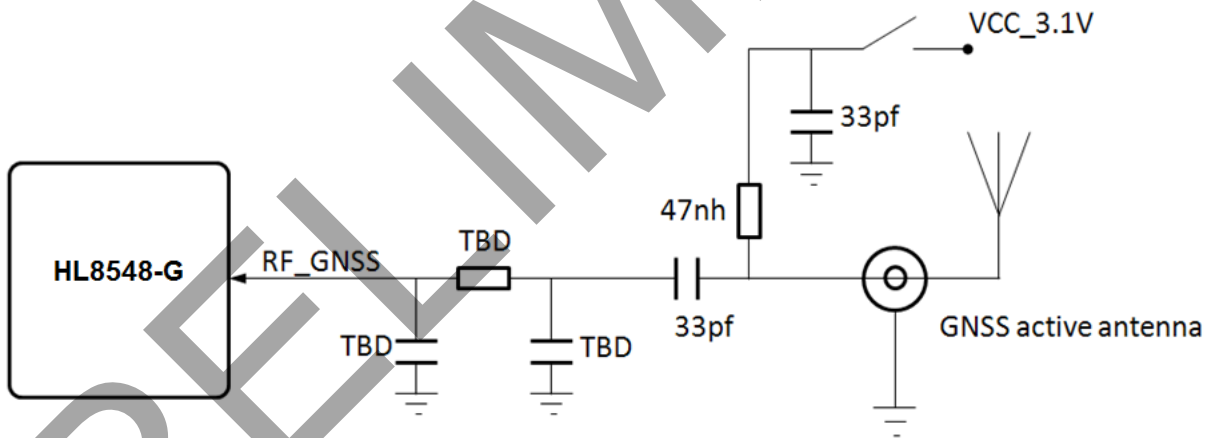

Figure 8. GNSS Application with Active Antenna

>> 5. X-Ray Exposure

X-ray exposure results in an undesirable shift in programmed bit threshold voltage of the Flash memory.

As a result, Sierra Wireless recommends avoiding any X-ray exposure during customer manufacturing process to ensure software integrity and long term reliability.

In case X-ray inspection could not be eliminated from the customer manufacturing process, a variety of mitigation methods should be implemented to lower the risk of potential failure:

- Use of filter between source and module to minimize exposure to harmful soft X-ray
 - 300 μ m Zn filter or 1mm Al filter are optimal
 - Zn and Al absorb soft X-ray to which silicon is particularly vulnerable, and transmit soft and medium energy X-rays required to obtain good imaging
- Minimize X-Ray dose
 - should be less than 10 RADs
 - KV peak should be less than 50KV peak
 - tube current should be less than 20 μ A
- Maximize distance between source and the module
- Minimize the X-ray time
 - use the shortest exposure time possible
 - sampling only, not 100% inspection

Note that these mitigation guidelines are for information only as it's NOT possible to provide accurate acceptable or unacceptable X-ray exposure criteria, e.g. maximum safe dose rate, maximum safe exposure time, etc.

6. FCC/IC Legal Information

6.1. Label

The HL8548 and HL8548-G is labelled with its own FCC ID (TBD) on the shield side. When the module is installed in a customer's product, the FCC ID label on the module will not be visible. To avoid this case, an exterior label must be stuck on the surface of the customer's product to indicate the FCC ID of the enclosed module. This label can use wording such as the following: "Contains Transmitter module FCC ID: TBD" or "Contains FCC ID: TBD".

6.2. FCC Regulations

This device complies with part 15 of the FCC Rules. Operation is subject to the following two conditions:

1. This device may not cause harmful interference, and
2. this device must accept any interference received, including interference that may cause undesired operation.

This device has been tested and found to comply with the limits for a Class B digital device, pursuant to Part 15 of the FCC Rules. These limits are designed to provide reasonable protection against harmful interference in a residential installation. This equipment generates, uses and can radiate radio frequency energy and, if not installed and used in accordance with the instructions, may cause harmful interference to radio communications. However, there is no guarantee that interference will not occur in a particular installation. If this equipment does cause harmful interference to radio or television reception, which can be determined by turning the equipment off and on, the user is encouraged to try to correct the interference by one or more of the following measures:

1. Reorient or relocate the receiving antenna.
2. Increase the separation between the equipment and receiver.
3. Connect the equipment into an outlet on a circuit different from that to which the receiver is connected.
4. Consult the dealer or an experienced radio/TV technician for help.

Changes or modifications not expressly approved by the party responsible for compliance could void the user's authority to operate the equipment.

6.3. RF Exposure Information

This Modular Approval is limited to OEM installation for mobile and fixed applications only. The antenna installation and operating configurations of this transmitter, including any applicable source-based time-averaging duty factor, antenna gain and cable loss must satisfy MPE categorical Exclusion Requirements of §2.1091.

The antenna(s) used for this transmitter must be installed to provide a separation distance of at least 20 cm from all persons, must not be collocated or operating in conjunction with any other antenna or transmitter, except in accordance with FCC multi-transmitter product procedures.

The end user has no manual instructions to remove or install the device and a separate approval is required for all other operating configurations, including portable configurations with respect to 2.1093 and different antenna configurations.

According to the MPE RF explore report, maximum antenna gain allowed for use with this device is TBDdBi for GSM850 and TBDdBi for PCS1900.

When the module is installed in the host device, the FCC ID label must be visible through a window on the final device or it must be visible when an access panel, door or cover is easily re-moved. If not, a second label must be placed on the outside of the final device that contains the following text:
—Contains FCC ID: TBD

6.4. IC Regulations

IC Radiation Exposure Statement:

This equipment complies with IC RSS-102 radiation exposure limits set forth for an uncontrolled environment. This equipment should be installed and operated with minimum distance 20cm between the radiator & your body.

This device and its antenna(s) must not be co-located or operating in conjunction with any other antenna or transmitter.

This Class B digital apparatus complies with Canadian ICES-003.

Under Industry Canada regulations, this radio transmitter may only operate using an antenna of a type and maximum (or lesser) gain approved for the transmitter by Industry Canada. To reduce potential radio interference to other users, the antenna type and its gain should be so chosen that the equivalent isotropically radiated power (e.i.r.p) is not more than necessary for successful communication.

Labeling Requirements for the Host Device (from Section 3.2.1, RSS-Gen, Issue 3, December 2010): The host device shall be properly labeled to identify the module within the host device. The Industry Canada certification label of a module shall be clearly visible at all times when installed in the host device, otherwise the host device must be labeled to display the Industry Canada certification number of the module, preceded by the words – Contains transmitter module, or the word – Contains, or similar wording expressing the same meaning, as follows: Contains transmitter module IC: TBD.

This device complies with Industry Canada license-exempt RSS standard(s). Operation is subject to the following two conditions: (1) this device may not cause interference, and (2) this device must accept any interference, including interference that may cause undesired operation of the device. Le présent appareil est conforme aux CNR d'Industrie Canada applicables aux appareils radio exempts de licence.

This radio transmitter (identify the device by certification number, or model number if Category II) has been approved by Industry Canada to operate with the antenna types listed below with the maximum permissible gain and required antenna impedance for each antenna type indicated. Antenna types not included in this list, having a gain greater than the maximum gain indicated for that type, are strictly prohibited for use with this device.



7. Terms and Abbreviations

Abbreviation	Definition
ADC	Analog to Digital Converter
AGC	Automatic Gain Control
AT	Attention (prefix for modem commands)
CDMA	Code Division Multiple Access
CLK	Clock
CODEC	Coder DECoder
CPU	Central Processing Unit
DAC	Digital to Analog Converter
DTR	Data Terminal Ready
EGNOS	European Geostationary Navigation Overlay Service
EMC	ElectroMagnetic Compatibility
EMI	ElectroMagnetic Interference
EN	Enable
ESD	ElectroStatic Discharges
ETSI	European Telecommunications Standards Institute
FDMA	Frequency-division multiple access
GAGAN	GPS aided geo augmented navigation
GLONASS	GLObal NAVigation Satellite System
GND	GrouND
GNSS	Global Navigation Satellite System
GPIO	General Purpose Input Output
GPRS	General Packet Radio Service
GSM	Global System for Mobile communications
Hi Z	High impedance (Z)
IC	Integrated Circuit
IMEI	International Mobile Equipment Identification
I/O	Input / Output
LED	Light Emitting Diode
LNA	Low Noise Amplifier
MAX	MAXimum
MIN	MINimum
MSAS	Multi-functional Satellite Augmentation System
N/A	Not Applicable
PA	Power Amplifier
PC	Personal Computer
PCB	Printed Circuit Board
PCL	Power Control Level
PLL	Phase Lock Loop
PWM	Pulse Width Modulation
QZSS	Quasi-Zenith Satellite System

Abbreviation	Definition
RF	Radio Frequency
RFI	Radio Frequency Interference
RMS	Root Mean Square
RST	ReSeT
RTC	Real Time Clock
RX	Receive
SCL	Serial CLock
SDA	Serial DAta
SIM	Subscriber Identification Module
SMD	Surface Mounted Device/Design
SPI	Serial Peripheral Interface
SW	SoftWare
PSRAM	Pseudo Static RAM
TBC	To Be Confirmed
TBD	To Be Defined
TP	Test Point
TX	Transmit
TYP	TYPical
UART	Universal Asynchronous Receiver-Transmitter
UICC	Universal Integrated Circuit Card
USB	Universal Serial Bus
UIM	User Identity Module
VBATT	Main Supply Voltage from Battery or DC adapter
VSWR	Voltage Standing Wave Ratio
WAAS	Wide Area Augmentation System



SIERRA
WIRELESS