

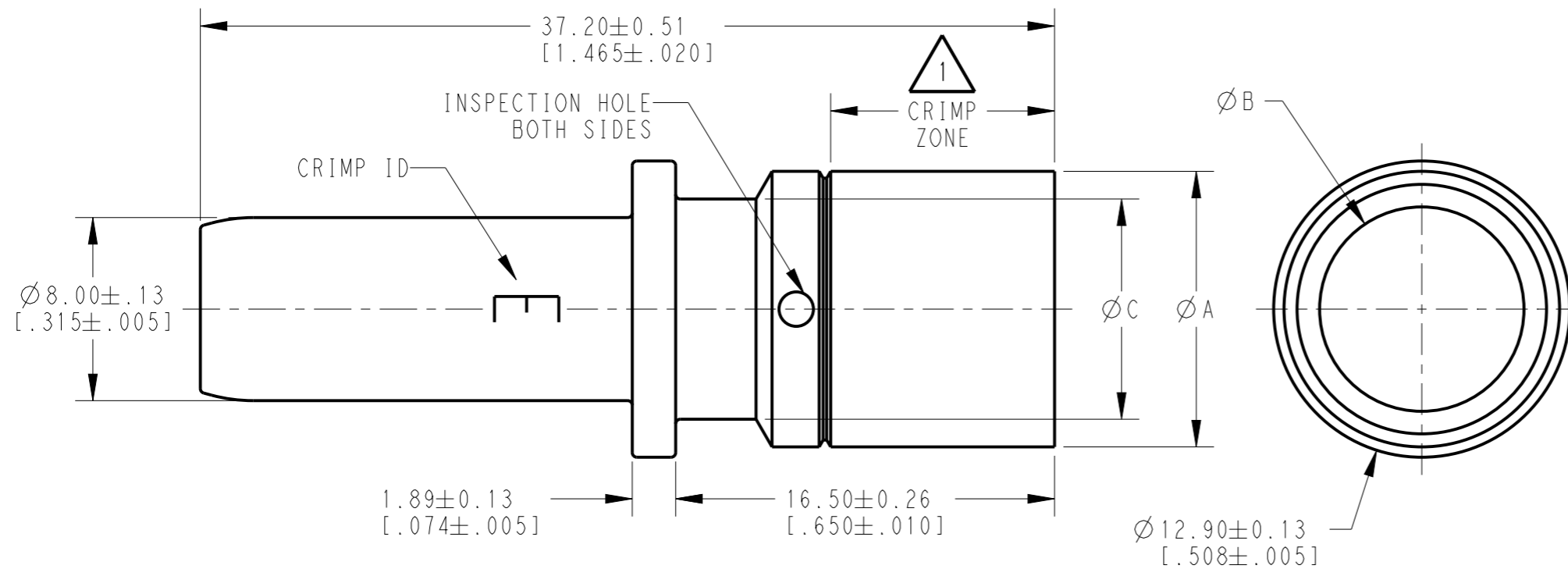

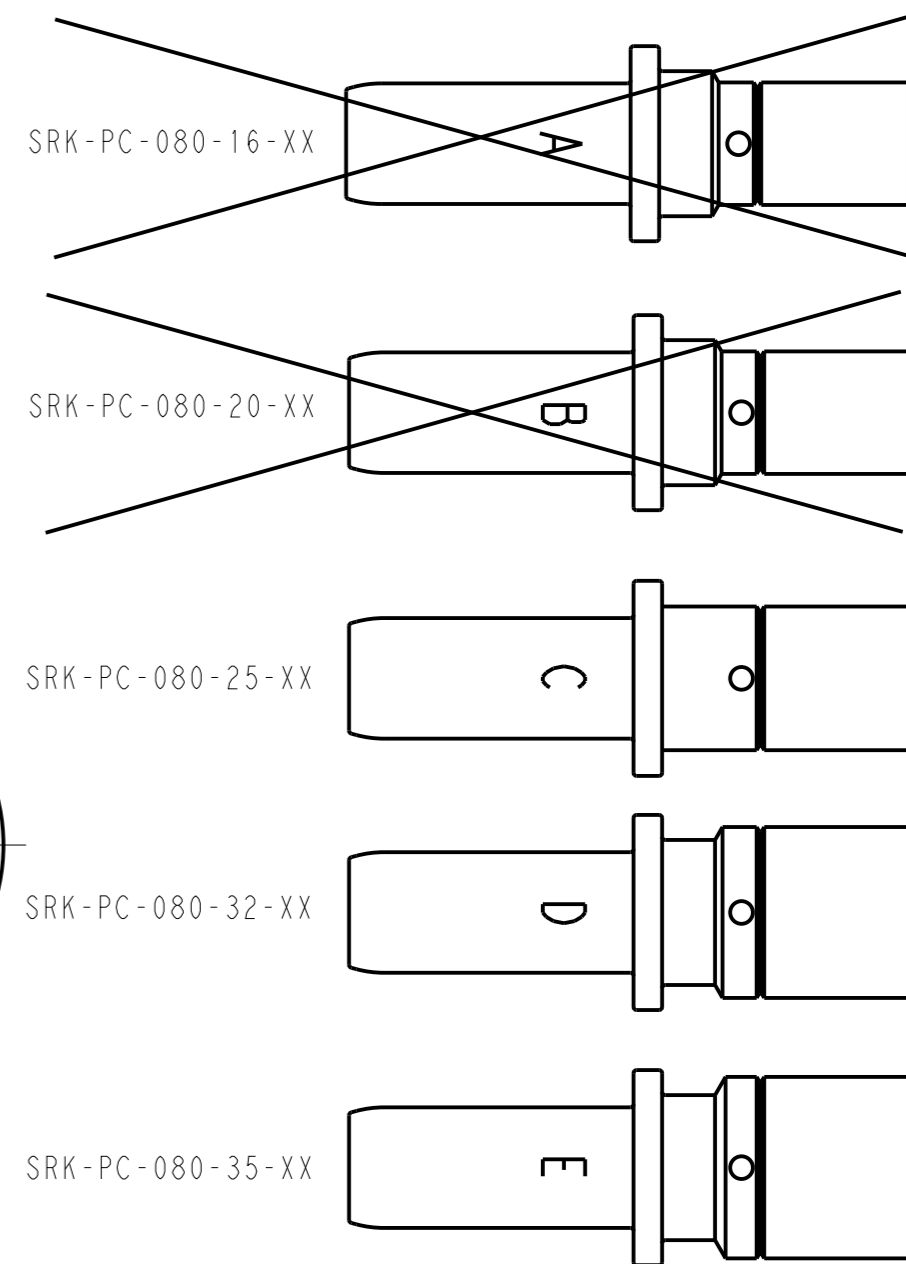

LOC	DIST	REVISIONS			
P	LTR	DESCRIPTION	DATE	DWN	APVD
	NC	NEW RELEASE PER E.O. P20459	05MAR2010	DAVID MEYER	
	A	REVISED PER E.O. P20612	09SEP2010	DM	RDR
	A1	REVISED PER ECO-15-012830	17SEP2015	JA	DM
	B	REVISED PER PCN-21-001241	12FEB2021	CL	IG

PART NUMBER	CRIMP ID	∅A ±.13 [.005]	∅B ±.13 [.005]	∅C ±.13 [.005]	CONDUCTOR WIRE SIZE REF 	WEIGHT REF GR [OZ]
SRK-PC-080-16-XX	A	8.10 [.319]	5.20 [.205]	9.59 [.378]	16mm ² 6 AWG	16.26 [.574]
SRK-PC-080-20-XX	B	8.10 [.319]	5.80 [.228]	9.59 [.378]	5 AWG	15.65 [.552]
SRK-PC-080-25-XX	C	9.50 [.374]	6.90 [.272]	9.50 [.374]	25mm ² 4 AWG	16.51 [.582]
SRK-PC-080-32-XX	D	11.30 [.445]	8.00 [.315]	9.59 [.374]	2 AWG	18.36 [.648]
SRK-PC-080-35-XX	E	12.00 [.472]	8.90 [.350]	9.59 [.374]	35mm ²	18.34 [.647]

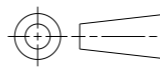

 WHEN XX = 601: PLATING IS SILVER AND MAY TARNISH.
 NOTES: UNLESS OTHERWISE SPECIFIED

THIS DRAWING IS A CONTROLLED DOCUMENT.		DWN 05MAR2010 DAVID G. MEYER	 TE Connectivity	
DIMENSIONS: mm [INCHES]		CHK 09SEP2010 DAVID G. MEYER		
TOLERANCES UNLESS OTHERWISE SPECIFIED:		APVD 09SEP2010 ROBIN REED	NAME CONTACT, SOCKET 8mm DIA SRK SERIES	
		PRODUCT SPEC N/A	RESTRICTED TO	
MATERIAL COPPER ALLOY		FINISH 	APPLICATION SPEC 114-151039	SIZE A3
		Customer Drawing	WEIGHT	CAGE CODE 4AFU8
			DRAWING NO SRK-PC-080-16/35-XX	SCALE 2:1
				SHEET 1 OF 1
				REV B