

FEATURES

- <1 pC charge injection over full signal range
- 1.5 pF off capacitance
- 33 V supply range
- 120 Ω on resistance
- Fully specified at ± 15 V/+12 V
- 3 V logic-compatible inputs
- Rail-to-rail operation
- Break-before-make switching action
- 28-lead TSSOP and 32-lead, 5 mm \times 5 mm LFCSP

APPLICATIONS

- Audio and video routing
- Automatic test equipment
- Data acquisition systems
- Battery-powered systems
- Sample-and-hold systems
- Communication systems

GENERAL DESCRIPTION

The [ADG1206](#) and [ADG1207](#) are monolithic *i*CMOS[®] analog multiplexers comprising sixteen single channels and eight differential channels, respectively. The [ADG1206](#) switches one of sixteen inputs to a common output, as determined by the 4-bit binary address lines A0, A1, A2, and A3. The [ADG1207](#) switches one of eight differential inputs to a common differential output, as determined by the 3-bit binary address lines A0, A1, and A2. An EN input on both devices is used to enable or disable the device. When disabled, all channels are switched off. When on, each channel conducts equally well in both directions and has an input signal range that extends to the supplies.

The industrial CMOS (*i*CMOS) modular manufacturing process combines high voltage, complementary metal-oxide semiconductor (CMOS) and bipolar technologies. It enables the development of a wide range of high performance analog ICs capable of 33 V operation in a footprint that no other generation of high voltage devices has been able to achieve. Unlike analog ICs using conventional CMOS processes, *i*CMOS components can tolerate high supply voltages while providing increased performance, dramatically lower power consumption, and reduced package size.

FUNCTIONAL BLOCK DIAGRAMS

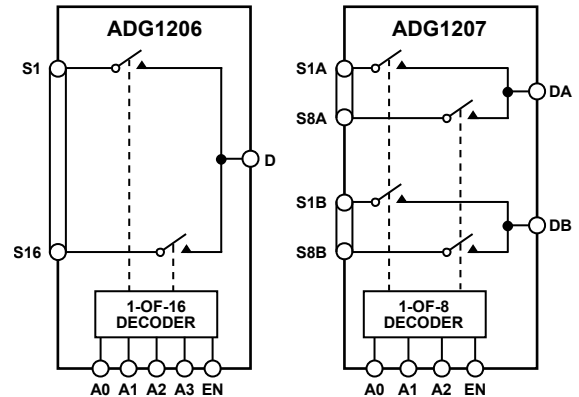

Figure 1.

The ultralow capacitance and exceptionally low charge injection of these multiplexers make them ideal solutions for data acquisition and sample-and-hold applications, where low glitch and fast settling are required. Figure 2 shows that there is minimum charge injection over the entire signal range of the device. *i*CMOS construction also ensures ultralow power dissipation, making the devices ideally suited for portable and battery-powered instruments.

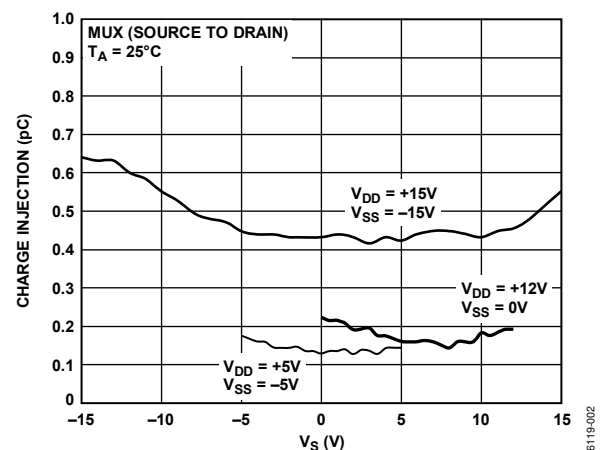

Figure 2. Source-to-Drain Charge Injection vs. Source Voltage

Rev. C

[Document Feedback](#)

Information furnished by Analog Devices is believed to be accurate and reliable. However, no responsibility is assumed by Analog Devices for its use, nor for any infringements of patents or other rights of third parties that may result from its use. Specifications subject to change without notice. No license is granted by implication or otherwise under any patent or patent rights of Analog Devices. Trademarks and registered trademarks are the property of their respective owners.

TABLE OF CONTENTS

Features	1	Absolute Maximum Ratings	7
Applications.....	1	ESD Caution.....	7
Functional Block Diagrams.....	1	Pin Configurations and Function Descriptions	8
General Description	1	Typical Performance Characteristics	12
Revision History	2	Terminology	16
Specifications.....	3	Test Circuits.....	17
Dual Supply	3	Outline Dimensions	19
Single Supply	5	Ordering Guide	19

REVISION HISTORY

6/2016—Rev. B to Rev. C

Changes to Analog Inputs Parameter, Table 3	7
Added Digital Inputs Parameter, Table 3	7

4/2016—Rev. A to Rev. B

Changed CP-32-2 to CP-32-7	Throughout
Changes to Figure 3, Figure 4, and Table 4	8
Changes to Figure 5, Figure 6, and Table 6	10
Updated Outline Dimensions	20
Changes to Ordering Guide	20

3/2009—Rev. 0 to Rev. A

Change to I _{DD} Parameter, Table 1	4
Change to I _{DD} Parameter, Table 2	6
Updated Outline Dimensions	19
Changes to Ordering Guide	19

7/2006—Revision 0: Initial Version

SPECIFICATIONS

DUAL SUPPLY

$V_{DD} = +15\text{ V} \pm 10\%$, $V_{SS} = -15\text{ V} \pm 10\%$, $GND = 0\text{ V}$, unless otherwise noted.¹

Table 1.

Parameter	Temperature			Unit	Test Conditions/Comments
	+25°C	-40°C to +85°C	-40°C to +125°C		
ANALOG SWITCH					
Analog Signal Range			V_{SS} to V_{DD}	V	
On Resistance, R_{ON}	120			Ω typ	$V_S = \pm 10\text{ V}$, $I_S = -1\text{ mA}$; see Figure 28
	200	240	270	Ω max	$V_{DD} = +13.5\text{ V}$, $V_{SS} = -13.5\text{ V}$
On-Resistance Match Between Channels, ΔR_{ON}	3.5			Ω typ	$V_S = \pm 10\text{ V}$, $I_S = -1\text{ mA}$
On-Resistance Flatness, R_{FLAT} (On)	6	10	12	Ω max	
	20			Ω typ	$V_S = -5\text{ V}, 0\text{ V}, +5\text{ V}$; $I_S = -1\text{ mA}$
	64	76	83	Ω max	
LEAKAGE CURRENTS					
Source Off Leakage, I_S (Off)	± 0.03			nA typ	$V_D = \pm 10\text{ V}$, $V_S = \mp 10\text{ V}$; see Figure 29
	± 0.2	± 0.6	± 1	nA max	
Drain Off Leakage, I_D (Off)	± 0.05			nA typ	$V_S = 1\text{ V}, 10\text{ V}$; $V_D = 10\text{ V}, 1\text{ V}$; see Figure 29
	± 0.2	± 0.6	± 2	nA max	
Channel On Leakage, I_D, I_S (On)	± 0.08			nA typ	$V_S = V_D = \pm 10\text{ V}$; see Figure 30
	± 0.2	± 0.6	± 2	nA max	
DIGITAL INPUTS					
Input High Voltage, V_{INH}			2.0	V min	
Input Low Voltage, V_{INL}			0.8	V max	
Input Current, I_{INL} or I_{INH}	± 0.005			μA typ	$V_{IN} = V_{INL}$ or V_{INH}
			± 0.1	μA max	
Digital Input Capacitance, C_{IN}	2			pF typ	
DYNAMIC CHARACTERISTICS²					
Transition Time, $t_{TRANSITION}$	80			ns typ	$R_L = 300\ \Omega$, $C_L = 35\text{ pF}$
	130	165	185	ns max	$V_S = 10\text{ V}$; see Figure 31
t_{ON} (EN)	75			ns typ	$R_L = 300\ \Omega$, $C_L = 35\text{ pF}$
	95	105	115	ns max	$V_S = 10\text{ V}$; see Figure 33
t_{OFF} (EN)	85			ns typ	$R_L = 300\ \Omega$, $C_L = 35\text{ pF}$
	100	125	140	ns max	$V_S = 10\text{ V}$; see Figure 33
Break-Before-Make Time Delay, t_{BBM}	20			ns typ	$R_L = 300\ \Omega$, $C_L = 35\text{ pF}$
			10	ns min	$V_{S1} = V_{S2} = 10\text{ V}$; see Figure 32
Charge Injection	0.5			pC typ	$V_S = 0\text{ V}$, $R_S = 0\ \Omega$, $C_L = 1\text{ nF}$; see Figure 34
Off Isolation	-85			dB typ	$R_L = 50\ \Omega$, $C_L = 5\text{ pF}$, $f = 1\text{ MHz}$; see Figure 35
Channel-to-Channel Crosstalk	-85			dB typ	$R_L = 50\ \Omega$, $C_L = 5\text{ pF}$, $f = 1\text{ MHz}$; see Figure 37
Total Harmonic Distortion Plus Noise	0.15			% typ	$R_L = 10\text{ k}\Omega$, 5 V rms , $f = 20\text{ Hz to } 20\text{ kHz}$; see Figure 38
-3 dB Bandwidth, ADG1206	280			MHz typ	$R_L = 50\ \Omega$, $C_L = 5\text{ pF}$; see Figure 36
-3 dB Bandwidth, ADG1207	490			MHz typ	$R_L = 50\ \Omega$, $C_L = 5\text{ pF}$; see Figure 36
C_S (Off)	1.5			pF typ	$f = 1\text{ MHz}$, $V_S = 0\text{ V}$
	2			pF max	$f = 1\text{ MHz}$, $V_S = 0\text{ V}$
C_D (Off), ADG1206	11			pF typ	$f = 1\text{ MHz}$, $V_S = 0\text{ V}$
	12			pF max	$f = 1\text{ MHz}$, $V_S = 0\text{ V}$
C_D (Off), ADG1207	7			pF typ	$f = 1\text{ MHz}$, $V_S = 0\text{ V}$
	9			pF max	$f = 1\text{ MHz}$, $V_S = 0\text{ V}$

Parameter	+25°C	-40°C to +85°C	-40°C to +125°C	Unit	Test Conditions/Comments
	C_D, C_S (On), ADG1206	13			
C_D, C_S (On), ADG1207	15			pF max	$f = 1 \text{ MHz}, V_S = 0 \text{ V}$
	8			pF typ	$f = 1 \text{ MHz}, V_S = 0 \text{ V}$
	10			pF max	$f = 1 \text{ MHz}, V_S = 0 \text{ V}$
POWER REQUIREMENTS					
I_{DD}	0.002		1.0	$\mu\text{A typ}$ $\mu\text{A max}$	$V_{DD} = +16.5 \text{ V}, V_{SS} = -16.5 \text{ V}$ Digital inputs = 0 V or V_{DD}
I_{DD}	260		475	$\mu\text{A typ}$ $\mu\text{A max}$	Digital inputs = 5 V
I_{SS}	0.002		1.0	$\mu\text{A typ}$ $\mu\text{A max}$	Digital inputs = 0 V, 5 V, or V_{DD}
V_{DD}/V_{SS}			$\pm 5/\pm 16.5$	V min/max	GND = 0V

¹ Temperature range for Y version is -40°C to $+125^\circ\text{C}$.

² Guaranteed by design, not subject to production test.

SINGLE SUPPLY

$V_{DD} = 12\text{ V} \pm 10\%$, $V_{SS} = 0\text{ V}$, $GND = 0\text{ V}$, unless otherwise noted.¹

Table 2.

Parameter	+25°C	-40°C to +85°C	-40°C to +125°C	Unit	Test Conditions/Comments
ANALOG SWITCH					
Analog Signal Range			0 to V_{DD}	V	
On Resistance, R_{ON}	300			Ω typ	$V_S = 0\text{ V}$ to 10 V , $I_S = -1\text{ mA}$; see Figure 28
	475	567	625	Ω max	$V_{DD} = 10.8\text{ V}$, $V_{SS} = 0\text{ V}$
On-Resistance Match Between Channels, ΔR_{ON}	5			Ω typ	$V_S = 0\text{ V}$ to 10 V , $I_S = -1\text{ mA}$
On-Resistance Flatness, R_{FLAT} (On)	16	26	27	Ω max	
	60			Ω typ	$V_S = 3\text{ V}$, 6 V , 9 V ; $I_S = -1\text{ mA}$
LEAKAGE CURRENTS					
Source Off Leakage, I_S (Off)	± 0.02			nA typ	$V_{DD} = 13.2\text{ V}$
	± 0.2	± 0.6	± 1	nA max	$V_S = 1\text{ V}/10\text{ V}$, $V_D = 10\text{ V}/1\text{ V}$; see Figure 29
Drain Off Leakage, I_D (Off)	± 0.05			nA typ	
	± 0.2	± 0.6	± 2	nA max	$V_S = 1\text{ V}/10\text{ V}$, $V_D = 10\text{ V}/1\text{ V}$; see Figure 29
Channel On Leakage, I_D , I_S (On)	± 0.08			nA typ	
	± 0.2	± 0.6	± 2	nA max	$V_S = V_D = 1\text{ V}$ or 10 V ; see Figure 30
DIGITAL INPUTS					
Input High Voltage, V_{INH}			2.0	V min	
Input Low Voltage, V_{INL}			0.8	V max	
Input Current, I_{INL} or I_{INH}	± 0.001			μA typ	
			± 0.1	μA max	$V_{IN} = V_{INL}$ or V_{INH}
Digital Input Capacitance, C_{IN}	3			pF typ	
DYNAMIC CHARACTERISTICS²					
Transition Time, $t_{TRANSITION}$	100			ns typ	$R_L = 300\ \Omega$, $C_L = 35\text{ pF}$
	140	175	200	ns max	$V_S = 8\text{ V}$; see Figure 31
t_{ON} (EN)	80			ns typ	$R_L = 300\ \Omega$, $C_L = 35\text{ pF}$
	100	120	130	ns max	$V_S = 8\text{ V}$; see Figure 33
t_{OFF} (EN)	90			ns typ	$R_L = 300\ \Omega$, $C_L = 35\text{ pF}$
	110	130	155	ns max	$V_S = 8\text{ V}$; see Figure 33
Break-Before-Make Time Delay, t_{BBM}	25			ns typ	$R_L = 300\ \Omega$, $C_L = 35\text{ pF}$
			15	ns min	$V_{S1} = V_{S2} = 8\text{ V}$; see Figure 32
Charge Injection	0.2			pC typ	$V_S = 6\text{ V}$, $R_S = 0\ \Omega$, $C_L = 1\text{ nF}$; see Figure 34
Off Isolation	-85			dB typ	$R_L = 50\ \Omega$, $C_L = 5\text{ pF}$, $f = 1\text{ MHz}$; see Figure 35
Channel-to-Channel Crosstalk	-85			dB typ	$R_L = 50\ \Omega$, $C_L = 5\text{ pF}$, $f = 1\text{ MHz}$; see Figure 37
-3 dB Bandwidth, ADG1206	185			MHz typ	$R_L = 50\ \Omega$, $C_L = 5\text{ pF}$; see Figure 36
-3 dB Bandwidth, ADG1207	300			MHz typ	$R_L = 50\ \Omega$, $C_L = 5\text{ pF}$; see Figure 36
C_S (Off)	1.5			pF typ	$f = 1\text{ MHz}$, $V_S = 6\text{ V}$
	2			pF max	$f = 1\text{ MHz}$, $V_S = 6\text{ V}$
C_D (Off), ADG1206	13			pF typ	$f = 1\text{ MHz}$, $V_S = 6\text{ V}$
	15			pF max	$f = 1\text{ MHz}$, $V_S = 6\text{ V}$
C_D (Off), ADG1207	9			pF typ	$f = 1\text{ MHz}$, $V_S = 6\text{ V}$
	11			pF max	$f = 1\text{ MHz}$, $V_S = 6\text{ V}$
C_D , C_S (On), ADG1206	15			pF typ	$f = 1\text{ MHz}$, $V_S = 6\text{ V}$
	17			pF max	$f = 1\text{ MHz}$, $V_S = 6\text{ V}$
C_D , C_S (On), ADG1207	10			pF typ	$f = 1\text{ MHz}$, $V_S = 6\text{ V}$
	12			pF max	$f = 1\text{ MHz}$, $V_S = 6\text{ V}$

Parameter	+25°C	-40°C to +85°C	-40°C to +125°C	Unit	Test Conditions/Comments
POWER REQUIREMENTS					$V_{DD} = 13.2\text{ V}$
I_{DD}	0.002			$\mu\text{A typ}$	Digital inputs = 0 V or V_{DD}
			1.0	$\mu\text{A max}$	
I_{DD}	260			$\mu\text{A typ}$	Digital inputs = 5 V
			475	$\mu\text{A max}$	
V_{DD}			5/16.5	V min/max	$V_{SS} = 0\text{ V}$, GND = 0 V

¹ Temperature range for Y version is -40°C to +125°C.

² Guaranteed by design, not subject to production test.

ABSOLUTE MAXIMUM RATINGS

$T_A = 25^\circ\text{C}$, unless otherwise noted.

Table 3.

Parameter	Rating
V_{DD} to V_{SS}	35 V
V_{DD} to GND	-0.3 V to +25 V
V_{SS} to GND	+0.3 V to -25 V
Analog Inputs ¹	$V_{SS} - 0.3\text{ V}$ to $V_{DD} + 0.3\text{ V}$ or 30 mA, whichever occurs first
Digital Inputs ¹	GND - 0.3 V to $V_{DD} + 0.3\text{ V}$ or 30 mA, whichever occurs first
Continuous Current, S or D	30 mA
Peak Current, S or D (Pulsed at 1 ms, 10% Duty Cycle Maximum)	100 mA
Operating Temperature Range	
Industrial (Y Version)	-40°C to +125°C
Storage	-65°C to +150°C
Junction Temperature	150°C
Thermal Impedance	
28-Lead TSSOP	
θ_{JA}	97.9°C/W
θ_{JC}	14°C/W
32-Lead LFCSP	
θ_{JA}	27.27°C/W
Reflow Soldering Peak Temperature (RoHS Compliant)	260(+0/-5)°C

¹ Overvoltages at A, EN, S, or D are clamped by internal diodes. Current should be limited to the maximum ratings given.

Stresses at or above those listed under Absolute Maximum Ratings may cause permanent damage to the product. This is a stress rating only; functional operation of the product at these or any other conditions above those indicated in the operational section of this specification is not implied. Operation beyond the maximum operating conditions for extended periods may affect product reliability.

Only one absolute maximum rating may be applied at any one time.

ESD CAUTION



ESD (electrostatic discharge) sensitive device. Charged devices and circuit boards can discharge without detection. Although this product features patented or proprietary protection circuitry, damage may occur on devices subjected to high energy ESD. Therefore, proper ESD precautions should be taken to avoid performance degradation or loss of functionality.

PIN CONFIGURATIONS AND FUNCTION DESCRIPTIONS

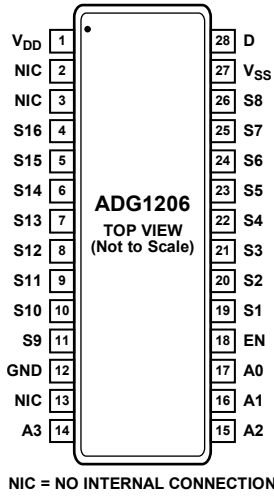

Figure 3. 28-Lead TSSOP Pin Configuration (ADG1206)

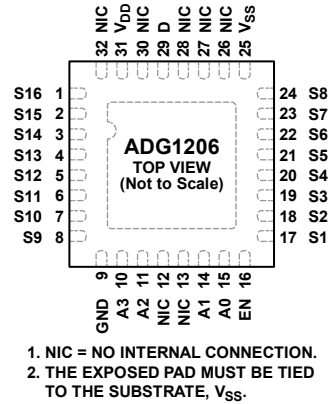

Figure 4. 32-Lead LFCSP Pin Configuration (ADG1206)

Table 4. ADG1206 Pin Function Descriptions

Pin No.		Mnemonic	Description
TSSOP	LFCSP		
1	31	VDD	Most Positive Power Supply Potential.
2, 3, 13	12, 13, 26, 27, 28, 30, 32	NIC	No Internal Connection.
4	1	S16	Source Terminal 16. Can be an input or an output.
5	2	S15	Source Terminal 15. Can be an input or an output.
6	3	S14	Source Terminal 14. Can be an input or an output.
7	4	S13	Source Terminal 13. Can be an input or an output.
8	5	S12	Source Terminal 12. Can be an input or an output.
9	6	S11	Source Terminal 11. Can be an input or an output.
10	7	S10	Source Terminal 10. Can be an input or an output.
11	8	S9	Source Terminal 9. Can be an input or an output.
12	9	GND	Ground (0 V) Reference.
14	10	A3	Logic Control Input.
15	11	A2	Logic Control Input.
16	14	A1	Logic Control Input.
17	15	A0	Logic Control Input.
18	16	EN	Active High Digital Input. When this pin is low, the device is disabled and all switches are turned off. When this pin is high, the Ax logic inputs determine which switch is turned on.
19	17	S1	Source Terminal 1. Can be an input or an output.
20	18	S2	Source Terminal 2. Can be an input or an output.
21	19	S3	Source Terminal 3. Can be an input or an output.
22	20	S4	Source Terminal 4. Can be an input or an output.
23	21	S5	Source Terminal 5. Can be an input or an output.
24	22	S6	Source Terminal 6. Can be an input or an output.
25	23	S7	Source Terminal 7. Can be an input or an output.
26	24	S8	Source Terminal 8. Can be an input or an output.
27	25	VSS	Most Negative Power Supply Potential. In single-supply applications, this pin can be connected to ground.
28	29	D	Drain Terminal. Can be an input or an output.
Not applicable	0	EPAD	Exposed Pad. The exposed pad must be tied to the substrate, VSS.

Table 5. ADG1206 Truth Table

A3	A2	A1	A0	EN	On Switch
X	X	X	X	0	None
0	0	0	0	1	1
0	0	0	1	1	2
0	0	1	0	1	3
0	0	1	1	1	4
0	1	0	0	1	5
0	1	0	1	1	6
0	1	1	0	1	7
0	1	1	1	1	8
1	0	0	0	1	9
1	0	0	1	1	10
1	0	1	0	1	11
1	0	1	1	1	12
1	1	0	0	1	13
1	1	0	1	1	14
1	1	1	0	1	15
1	1	1	1	1	16

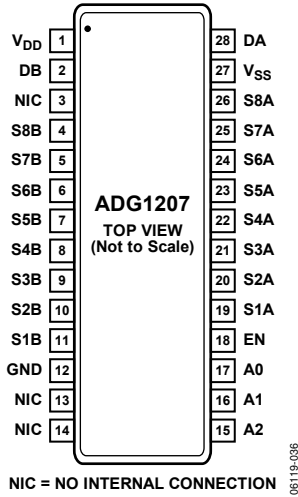

Figure 5. 28-Lead TSSOP Pin Configuration (ADG1207)

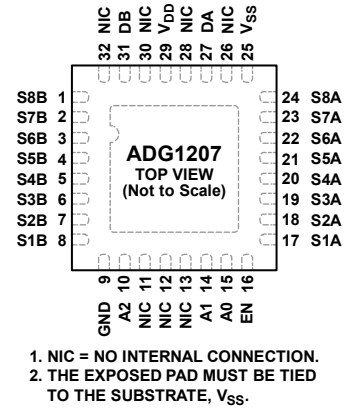

Figure 6. 32-Lead LFCSP Pin Configuration (ADG1207)

Table 6. ADG1207 Pin Function Descriptions

Pin No.		Mnemonic	Description
TSSOP	LFCSP		
1	29	V _{DD}	Most Positive Power Supply Potential.
2	31	DB	Drain Terminal B. Can be an input or an output.
3, 13, 14	11, 12, 13, 26, 28, 30, 32	NIC	No Internal Connection.
4	1	S8B	Source Terminal 8B. Can be an input or an output.
5	2	S7B	Source Terminal 7B. Can be an input or an output.
6	3	S6B	Source Terminal 6B. Can be an input or an output.
7	4	S5B	Source Terminal 5B. Can be an input or an output.
8	5	S4B	Source Terminal 4B. Can be an input or an output.
9	6	S3B	Source Terminal 3B. Can be an input or an output.
10	7	S2B	Source Terminal 2B. Can be an input or an output.
11	8	S1B	Source Terminal 1B. Can be an input or an output.
12	9	GND	Ground (0 V) Reference.
15	10	A2	Logic Control Input.
16	14	A1	Logic Control Input.
17	15	A0	Logic Control Input.
18	16	EN	Active High Digital Input. When this pin is low, the device is disabled and all switches are turned off. When this pin is high, the Ax logic inputs determine which switch is turned on.
19	17	S1A	Source Terminal 1A. Can be an input or an output.
20	18	S2A	Source Terminal 2A. Can be an input or an output.
21	19	S3A	Source Terminal 3A. Can be an input or an output.
22	20	S4A	Source Terminal 4A. Can be an input or an output.
23	21	S5A	Source Terminal 5A. Can be an input or an output.
24	22	S6A	Source Terminal 6A. Can be an input or an output.
25	23	S7A	Source Terminal 7A. Can be an input or an output.
26	24	S8A	Source Terminal 8A. Can be an input or an output.
27	25	V _{SS}	Most Negative Power Supply Potential. In single-supply applications, this pin can be connected to ground.
28	27	DA	Drain Terminal A. Can be an input or an output.
Not applicable	0	EPAD	Exposed Pad. The exposed pad must be tied to the substrate, V _{SS} .

Table 7. ADG1207 Truth Table

A2	A1	A0	EN	On Switch Pair
X	X	X	0	None
0	0	0	1	1
0	0	1	1	2
0	1	0	1	3
0	1	1	1	4
1	0	0	1	5
1	0	1	1	6
1	1	0	1	7
1	1	1	1	8

TYPICAL PERFORMANCE CHARACTERISTICS

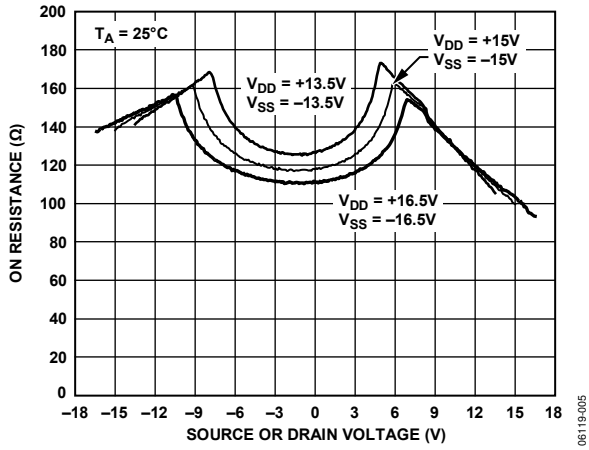

Figure 7. On Resistance as a Function of V_D (V_S) for Dual Supply

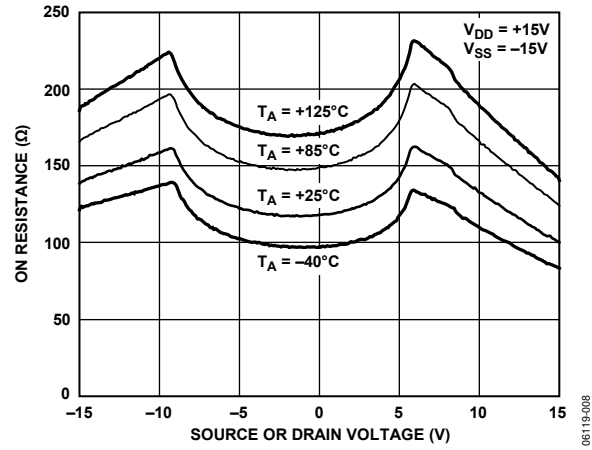

Figure 10. On Resistance as a Function of V_D (V_S) for Different Temperatures, Dual Supply

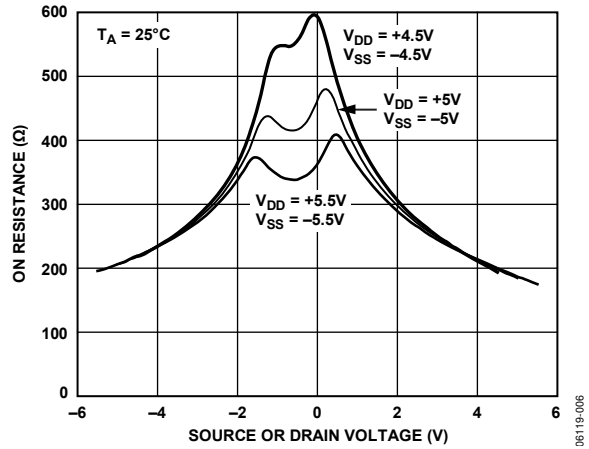

Figure 8. On Resistance as a Function of V_D (V_S) for Dual Supply

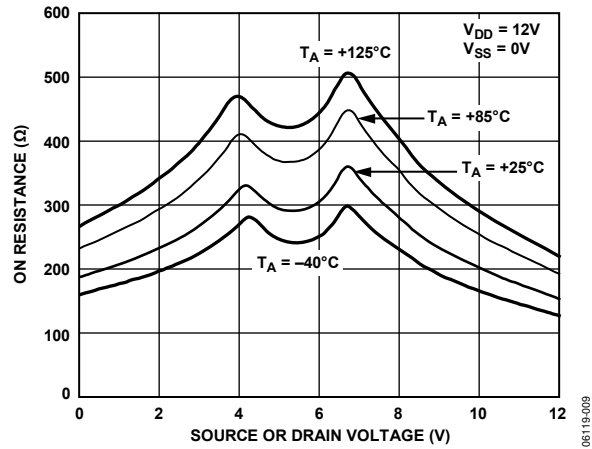

Figure 11. On Resistance as a Function of V_D (V_S) for Different Temperatures, Single Supply

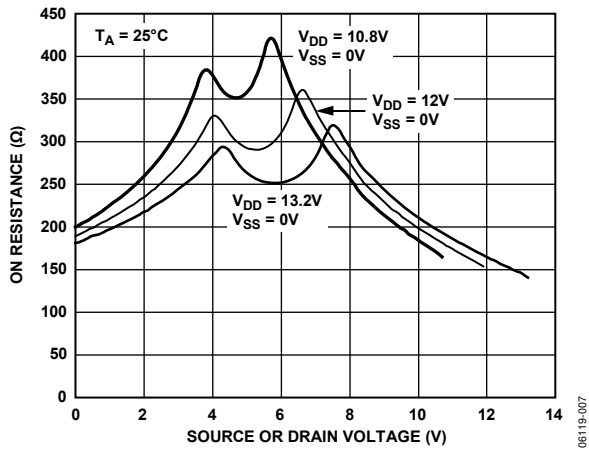

Figure 9. On Resistance as a Function of V_D (V_S) for Single Supply

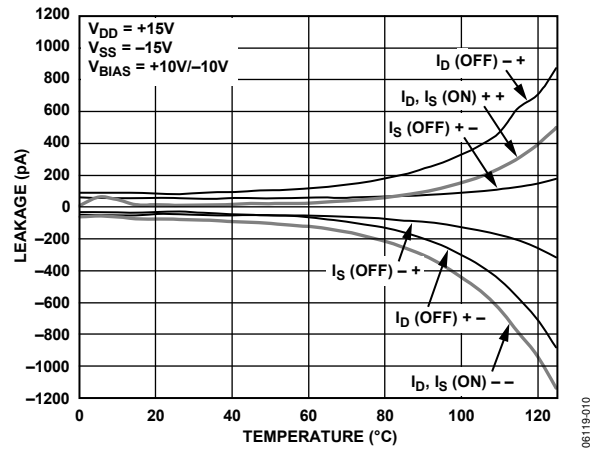

Figure 12. ADG1206 Leakage Currents as a Function of Temperature, Dual Supply

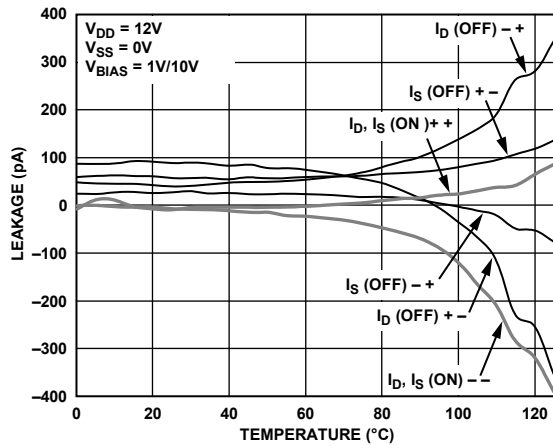

Figure 13. ADG1206 Leakage Currents as a Function of Temperature, Single Supply

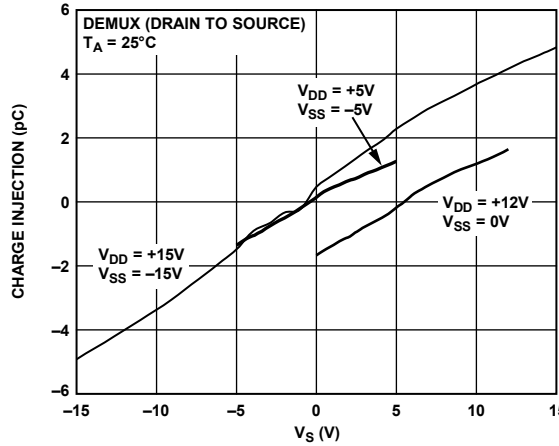

Figure 16. Drain-to-Source Charge Injection vs. Source Voltage

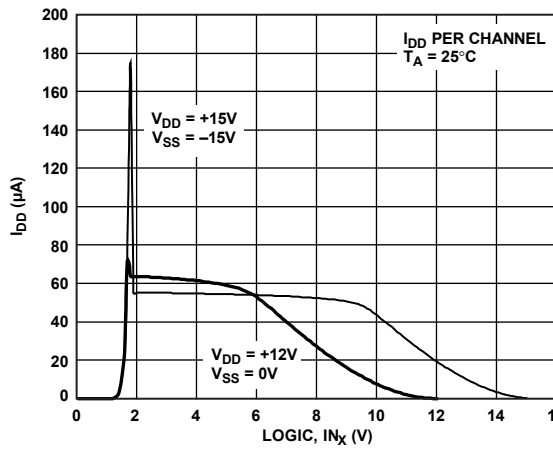

Figure 14. I_{DD} vs. Logic Level

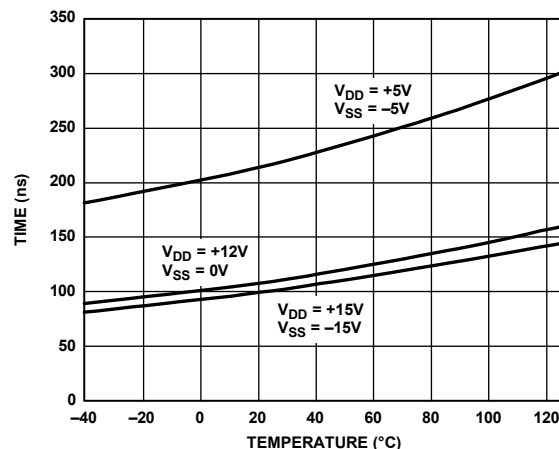

Figure 17. Transition Time vs. Temperature

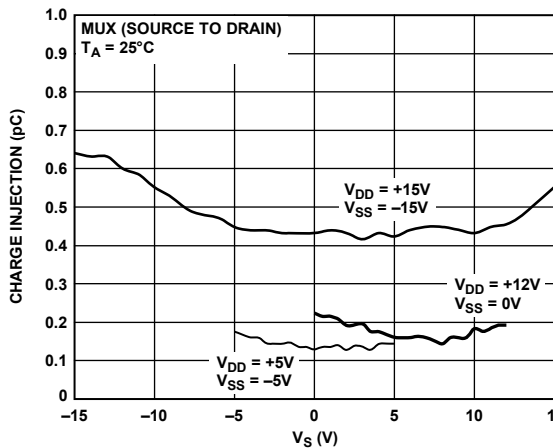

Figure 15. Source-to-Drain Charge Injection vs. Source Voltage

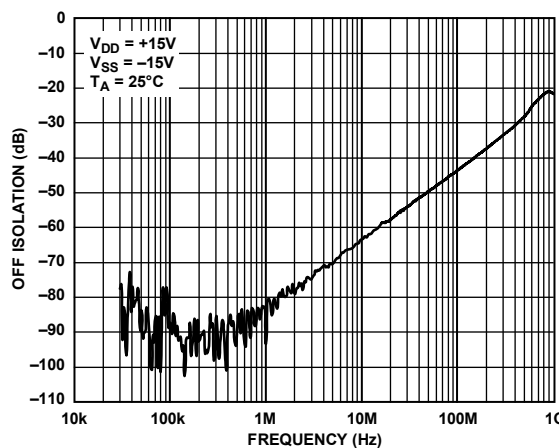

Figure 18. Off Isolation vs. Frequency

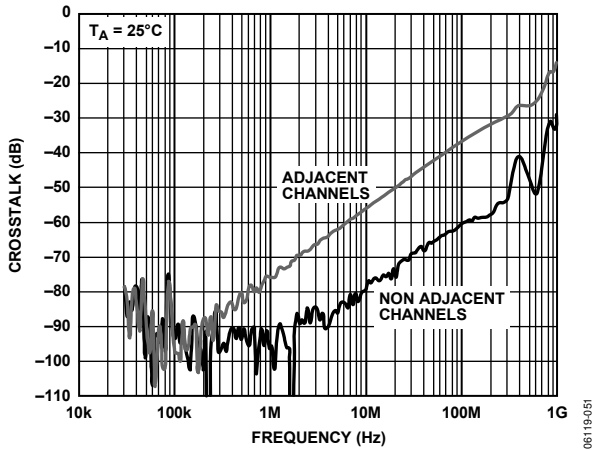

Figure 19. ADG1206 Crosstalk vs. Frequency

06119-051

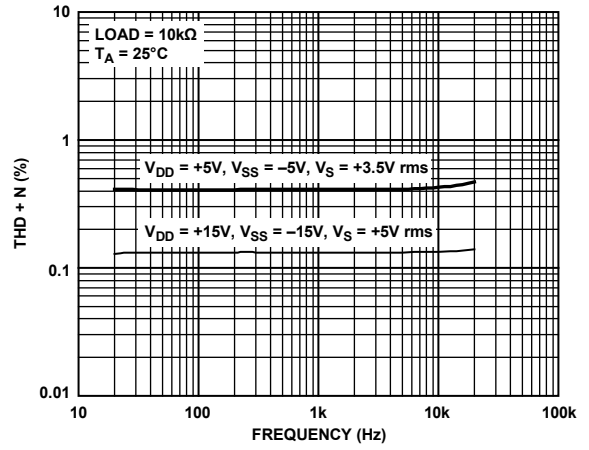

Figure 22. THD + N vs. Frequency

06119-020

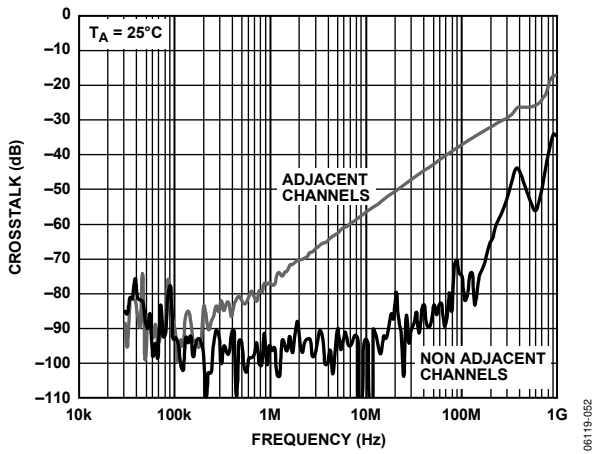

Figure 20. ADG1207 Crosstalk vs. Frequency

06119-052

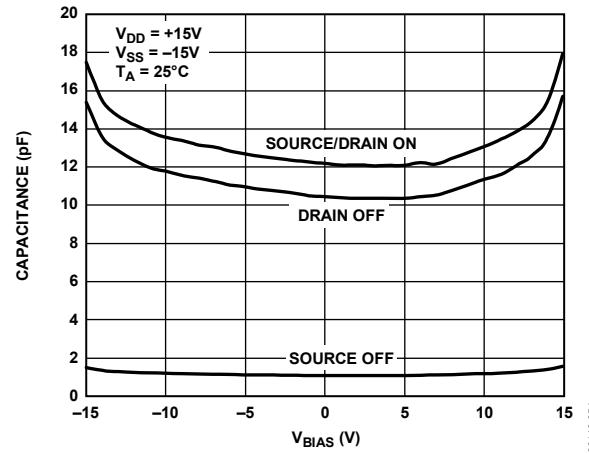

Figure 23. ADG1206 Capacitance vs. Source Voltage, ±15 V Dual Supply

06119-054

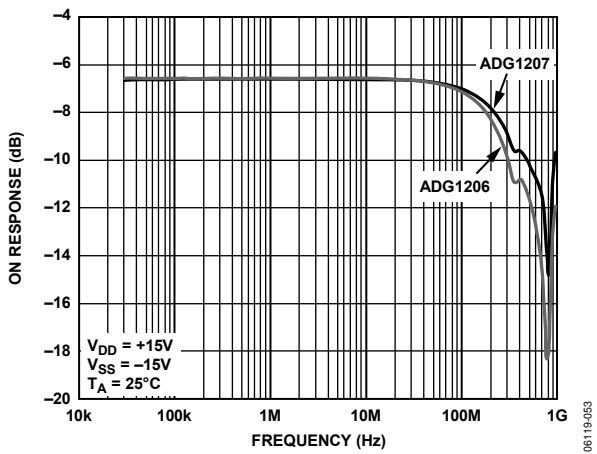

Figure 21. On Response vs. Frequency

06119-053

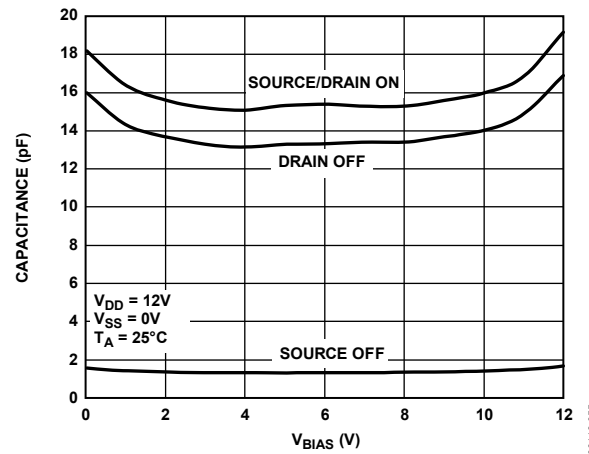

Figure 24. ADG1206 Capacitance vs. Source Voltage, 12 V Single Supply

06119-055

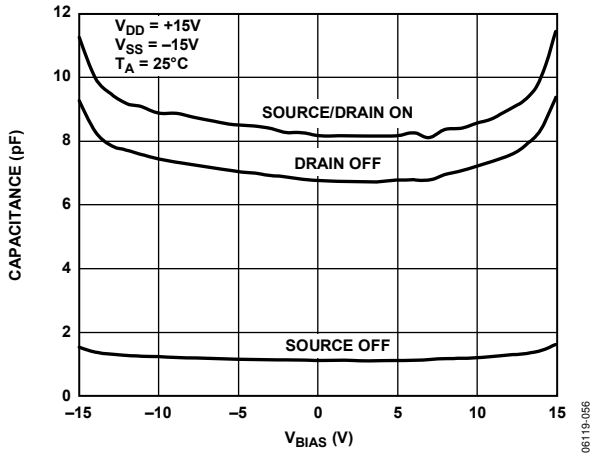

Figure 25. ADG1207 Capacitance vs. Source Voltage, ±15 V Dual Supply

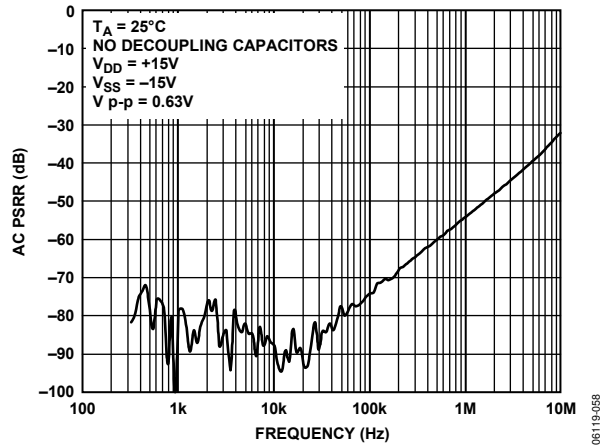

Figure 27. ACPSRR vs. Frequency

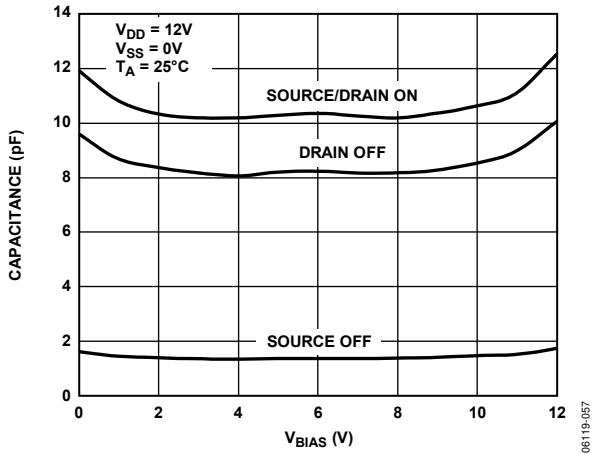

Figure 26. ADG1207 Capacitance vs. Source Voltage, 12 V Single Supply

TERMINOLOGY

R_{ON}

Ohmic resistance between D and S.

ΔR_{ON}

Difference between the R_{ON} of any two channels.

$R_{FLAT(ON)}$

Flatness is defined as the difference between the maximum and minimum value of on resistance as measured.

I_S (Off)

Source leakage current when the switch is off.

I_D (Off)

Drain leakage current when the switch is off.

I_D, I_S (On)

Channel leakage current when the switch is on.

V_D (Vs)

Analog voltage on Terminals D and S.

C_S (Off)

Channel input capacitance for the off condition.

C_D (Off)

Channel output capacitance for the off condition.

C_D, C_S (On)

On switch capacitance.

C_{IN}

Digital input capacitance.

t_{ON} (EN)

Delay time between the 50% and 90% points of the digital input and the switch on condition.

t_{OFF} (EN)

Delay time between the 50% and 90% points of the digital input and the switch off condition.

$t_{TRANSITION}$

Delay time between the 50% and 90% points of the digital inputs and the switch on condition when switching from one address state to another.

T_{BBM}

Off time measured between the 80% points of the switches when switching from one address state to another.

V_{INL}

Maximum input voltage for Logic 0.

V_{INH}

Minimum input voltage for Logic 1.

I_{INL} (I_{INH})

Input current of the digital input.

I_{DD}

Positive supply current.

I_{SS}

Negative supply current.

Off Isolation

A measure of unwanted signal coupling through an off channel.

Charge Injection

A measure of the glitch impulse transferred from the digital input to the analog output during switching.

Bandwidth

The frequency at which the output is attenuated by 3 dB.

On Response

The frequency response of the on switch.

Total Harmonic Distortion Plus Noise (THD + N)

The ratio of the harmonic amplitude plus noise of the signal to the fundamental.

AC Power Supply Rejection Ratio (ACPSRR)

Measures the ability of a device to avoid coupling noise and spurious signals that appear on the supply voltage pin to the output of the switch. The dc voltage on the device is modulated by a sine wave of 0.62 V p-p. The ratio of the amplitude of signal on the output to the amplitude of the modulation is the ACPSRR.

TEST CIRCUITS

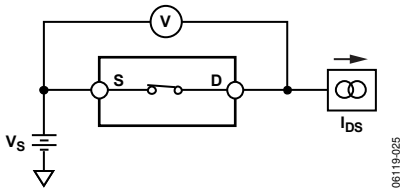

Figure 28. On Resistance

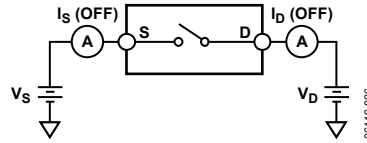

Figure 29. Off Leakage

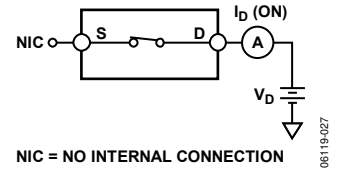

Figure 30. On Leakage

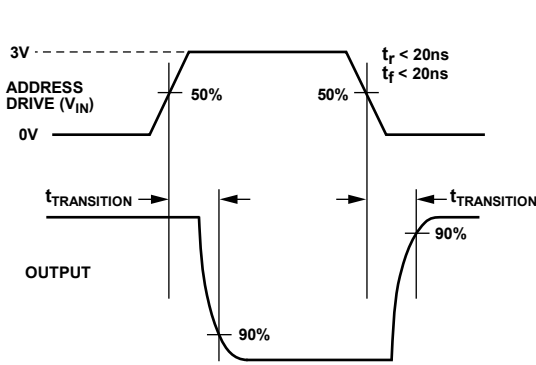
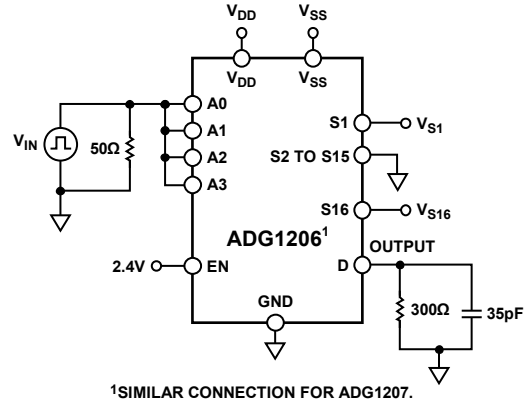

Figure 31. Address to Output Switching Times, $t_{TRANSITION}$



¹SIMILAR CONNECTION FOR ADG1207.

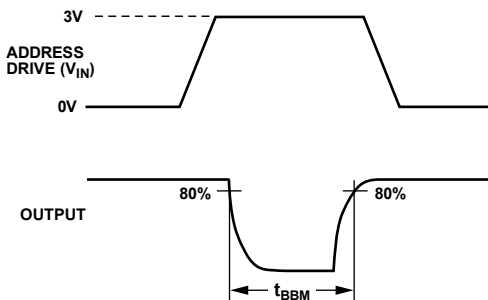
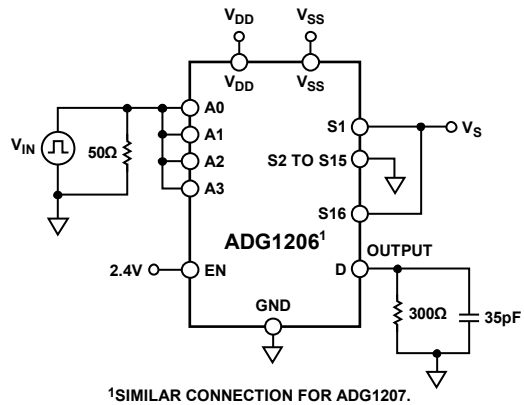

Figure 32. Break-Before-Make Delay, t_{BBM}



¹SIMILAR CONNECTION FOR ADG1207.

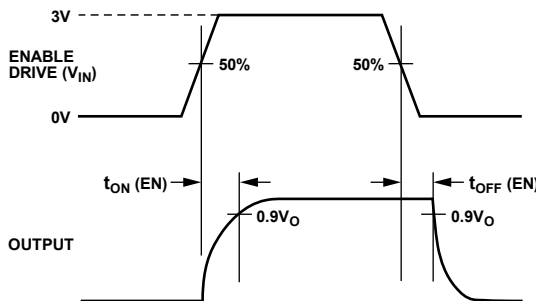
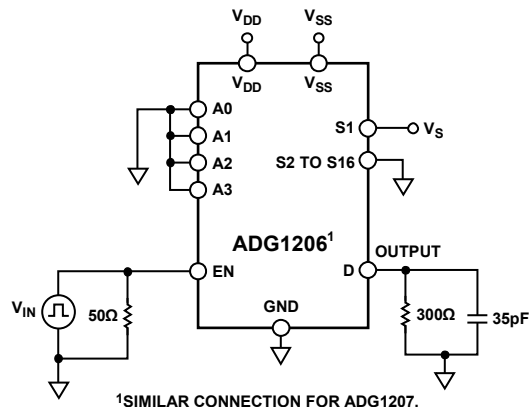
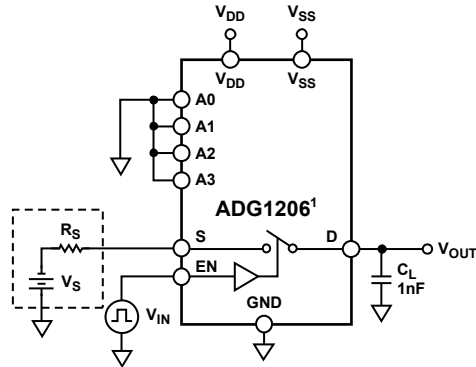
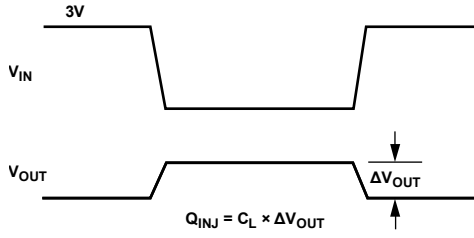

Figure 33. Enable Delay, $t_{ON}(EN)$, $t_{OFF}(EN)$



¹SIMILAR CONNECTION FOR ADG1207.



1SIMILAR CONNECTION FOR ADG1207.

06119-001

Figure 34. Charge Injection

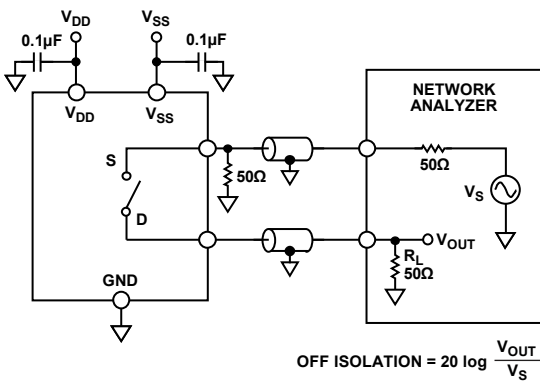

06119-032

Figure 35. Off Isolation

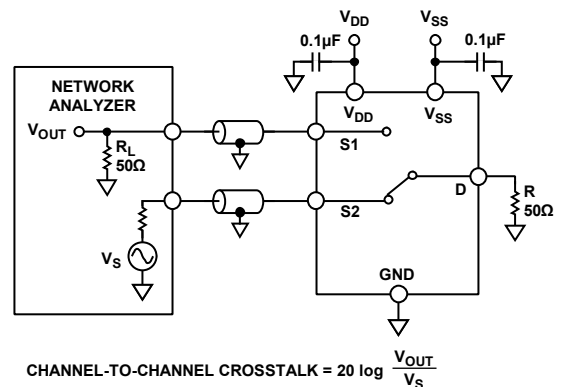

06119-034

Figure 37. Channel-to-Channel Crosstalk

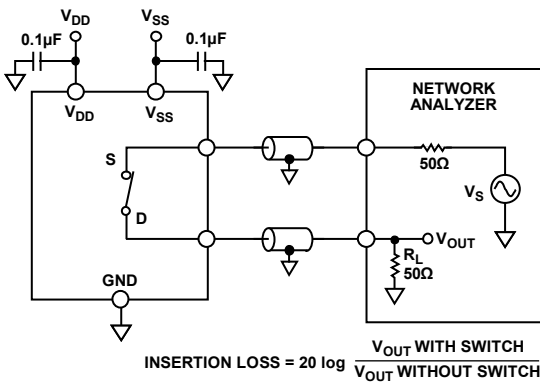

06119-033

Figure 36. Bandwidth

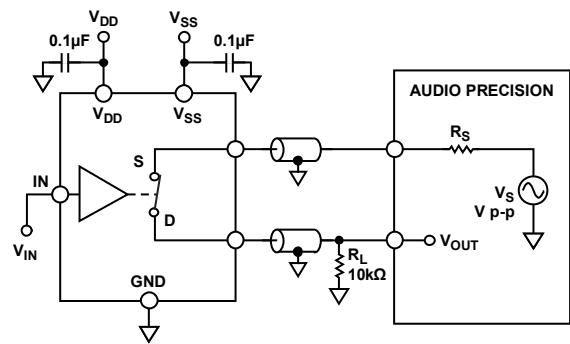

06119-035

Figure 38. THD + N

OUTLINE DIMENSIONS

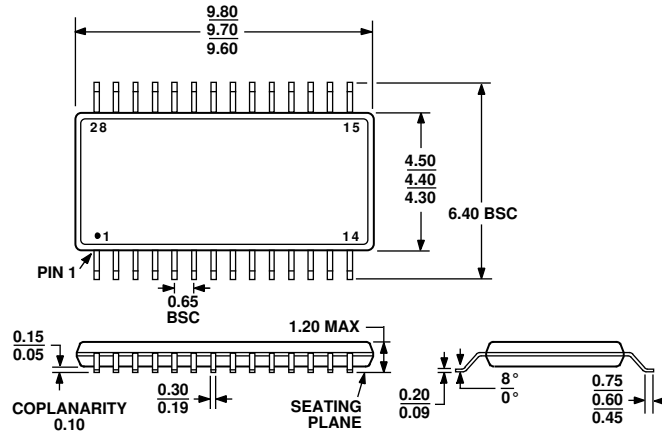

COMPLIANT TO JEDEC STANDARDS MO-153-AE

Figure 39. 28-Lead Thin Shrink Small Outline Package [TSSOP] (RU-28)
Dimensions shown in millimeters

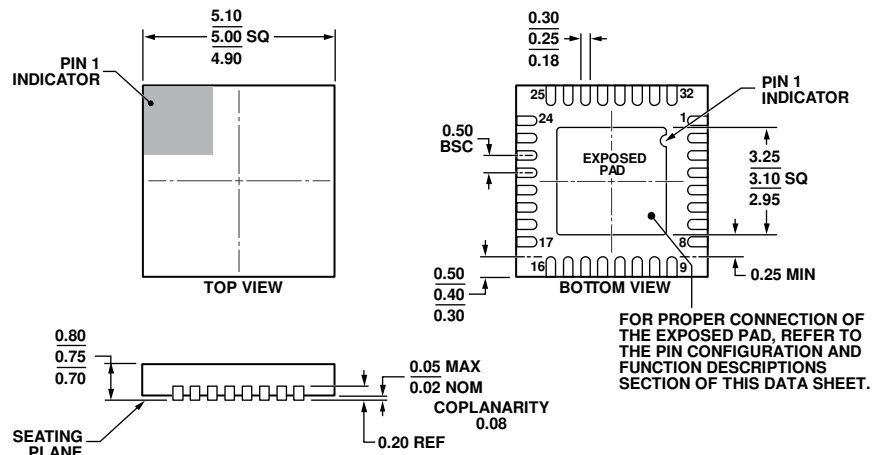

COMPLIANT TO JEDEC STANDARDS MO-220-WHHD.

Figure 40. 32-Lead Lead Frame Chip Scale Package [LFCSP] 5 mm × 5 mm Body and 0.75 mm Package Height (CP-32-7)
Dimensions shown in millimeters

ORDERING GUIDE

Model ¹	Temperature Range	Description	Package Option
ADG1206YRUZ	-40°C to +125°C	28-Lead Thin Shrink Small Outline Package [TSSOP]	RU-28
ADG1206YRUZ-REEL7	-40°C to +125°C	28-Lead Thin Shrink Small Outline Package [TSSOP]	RU-28
ADG1206YCPZ-REEL7	-40°C to +125°C	32-Lead Lead Frame Chip Scale Package [LFCSP]	CP-32-7
ADG1207YRUZ	-40°C to +125°C	28-Lead Thin Shrink Small Outline Package [TSSOP]	RU-28
ADG1207YRUZ-REEL7	-40°C to +125°C	28-Lead Thin Shrink Small Outline Package [TSSOP]	RU-28
ADG1207YCPZ-REEL7	-40°C to +125°C	32-Lead Lead Frame Chip Scale Package [LFCSP]	CP-32-7

¹ Z = RoHS Compliant Part.

NOTES