

FEATURES

- High performance, in-plane roll rate gyroscope**
- Temperature compensated, high precision offset and sensitivity performance**
- 2°/sec rms maximum gyroscope noise**
- Serial port interface (SPI) digital output with 16-bit data word**
- <20 mA quiescent current consumption**
- 3.3 V and 5 V operation**
- −40°C to +105°C temperature range**
- 16-lead SOIC_CAV surface-mount package for in-plane roll rate sensing**
- AEC-Q100 qualified for automotive applications**

APPLICATIONS

- Rollover detection**

GENERAL DESCRIPTION

The ADXRS910 is a high performance in-plane gyroscope, designed for automotive rollover detection applications. The ADXRS910 also has an internal temperature sensor that is used to compensate offset and sensitivity performance, providing excellent stability over the −40°C to +105°C temperature range.

The gyroscope provides a full-scale range of $\pm 300^\circ/\text{sec}$ with a sensitivity of 80 LSB/°/sec. Its resonating disk sensor structure enables angular rate measurement around an in-plane axis. The −3 dB filter corner frequency can be selected to be 27.6 Hz, 51.3 Hz, 109 Hz, or 196.8 Hz. The sensor data output from the device is a 16-bit, two's complement word contained in a 32-bit SPI transaction. SPI communications are compatible up to 10 MHz.

The ADXRS910 is available in a 16-lead inverted SOIC package. The ADXRS910 is specified to operate at 3.3 V and 5 V, with less than 20 mA of current consumption. Its specifications are valid over the −40°C to +105°C temperature range.

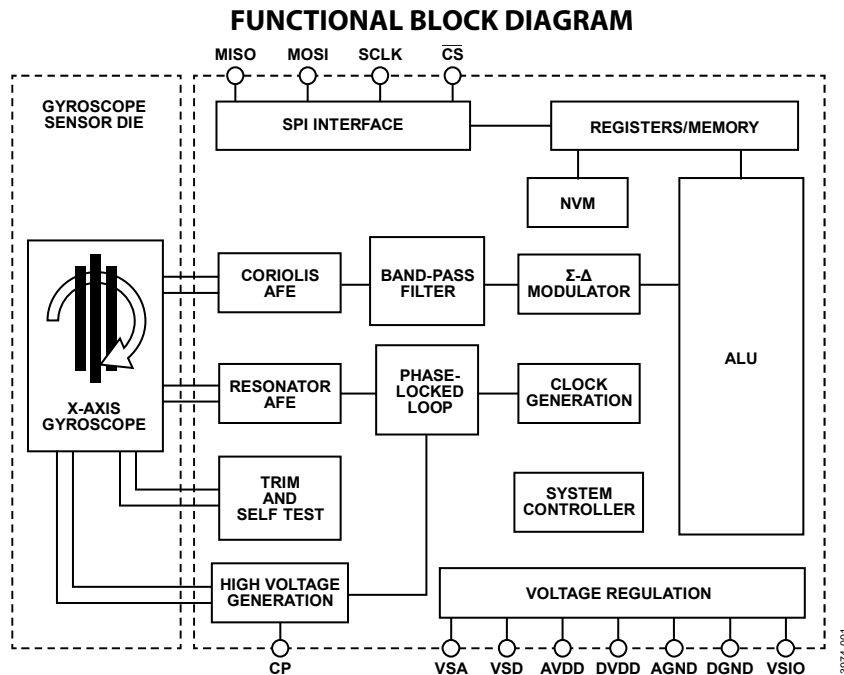

Figure 1.

For more information about the ADXRS910, contact the Analog Devices, Inc., Customer Interaction Center at www.analog.com/technical_support to connect with a technical support specialist.

NOTES