

NOTES:

1. MATERIALS AND FINISHES:
 BODY - BRASS, GOLD PLATING
 CONTACT - BeCu, GOLD PLATING
 INSULATOR - PTFE
2. ELECTRICAL:
 A. IMPEDANCE: 50 OHM
 B. FREQUENCY RANGE: DC - 6 GHz
 C. VSWR(RETURN LOSS): -32 dB TO 3 GHz MAX.; -25 dB TO 6 GHz MAX.
3. MECHANICAL:
 A. DURABILITY: 500 CYCLES MIN.
 B. TEMPERATURE RANGE: -65°C - +165°C
 C. CENTER CONTACT MUST WITHSTAND A 6LB. MIN AXIAL FORCE AND A 4IN. OZ. MIN. TORQUE
5. PACKAGING:
 A. QUANTITY: SINGLE PACK
 B. MARKING: BAG TO BE MARKED
 "AMPHENOL 930-159J-51S, AND DATE CODE YYWW"

THIRD ANGLE PROJ.

REVISIONS

REV	DESCRIPTION	DATE	ECO	APPR
A	RELEASE TO MFG	9/29/08	47121	RR
B	TRANSFER TO KJ	04-Mar-10	47999	SH

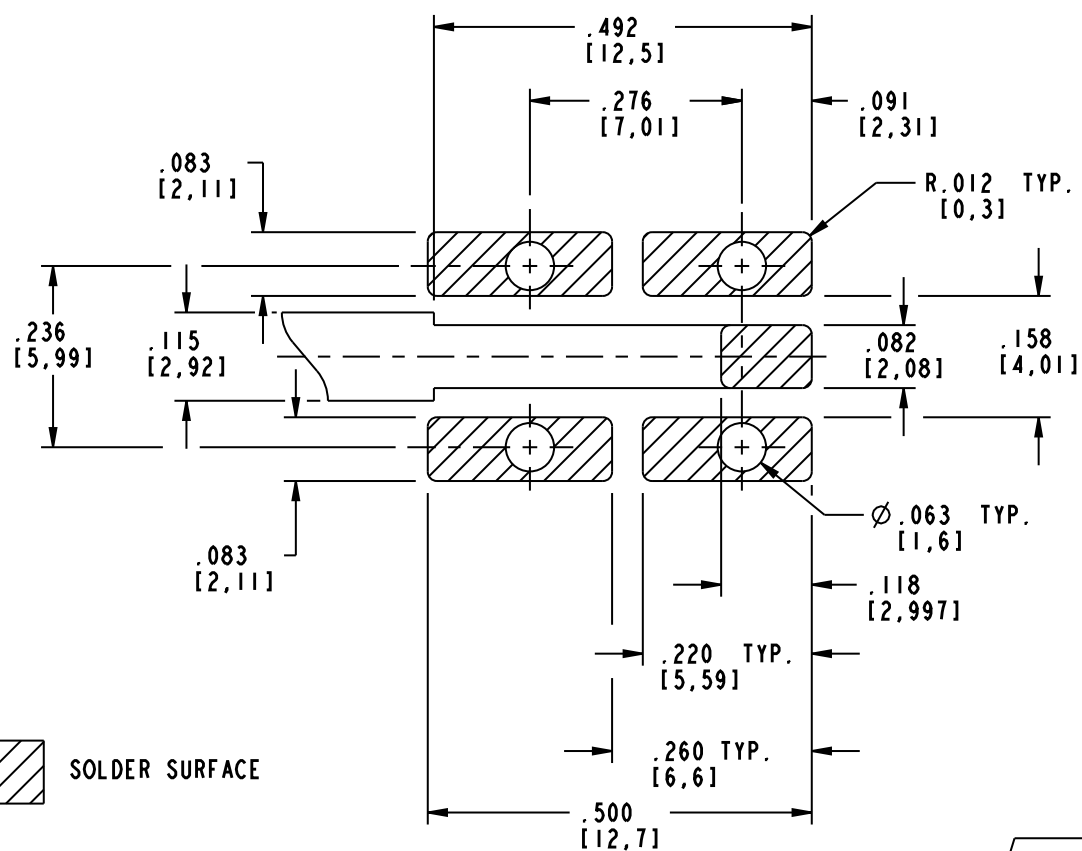

MOUNTING HOLES
 SOLDER SURFACES

SECTION B-B
 SCALE 4.000

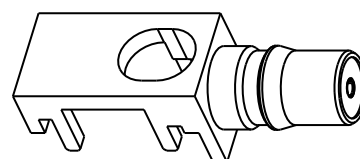

SCALE 2.000

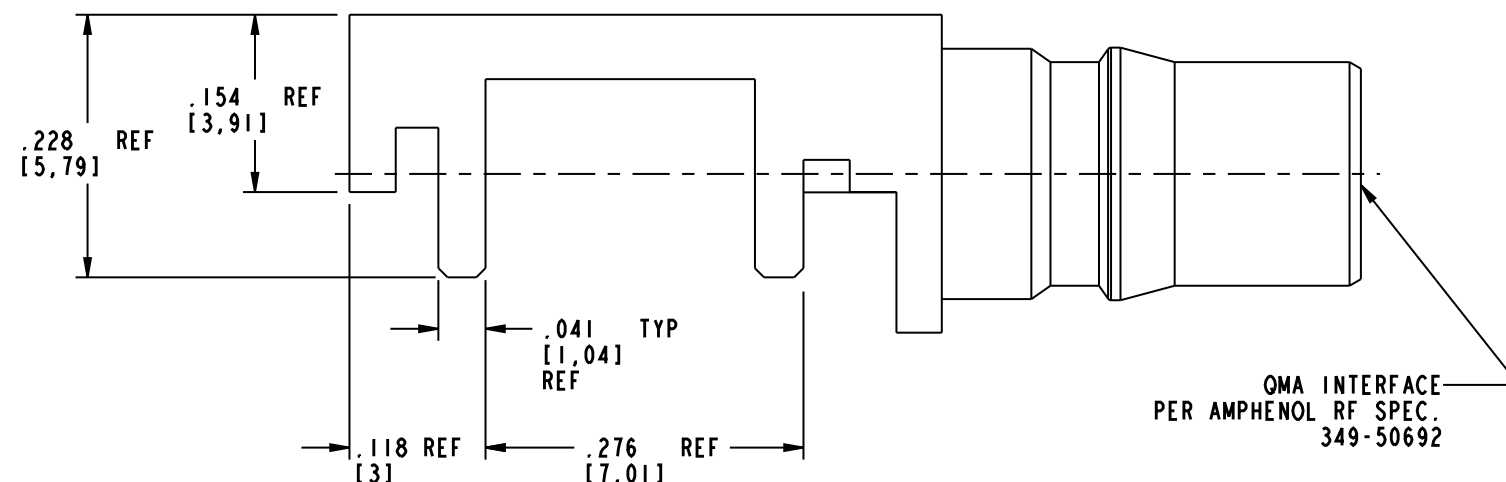
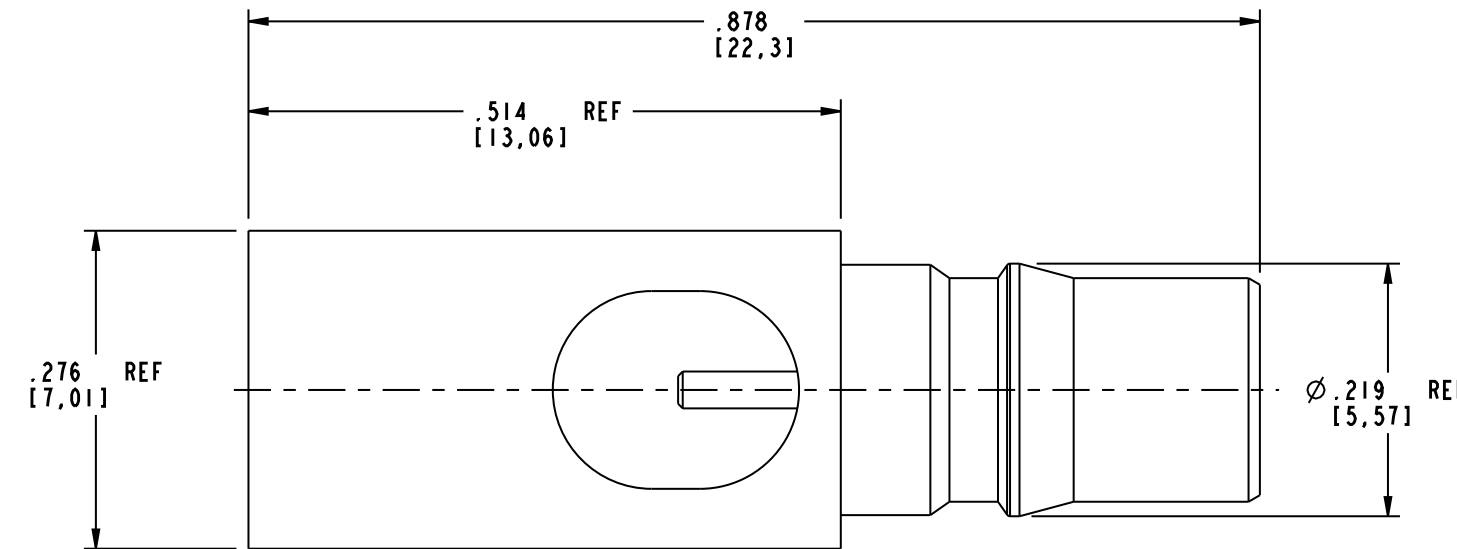

CUSTOMER OUTLINE DRAWING
 ALL OTHER SHEETS ARE FOR INTERNAL USE ONLY

UNLESS OTHERWISE SPECIFIED, DIMENSIONS ARE IN METRIC AND TOLERANCES ARE:
 <0.5mm ±0.05mm 0.5 - 6mm ±0.1mm 6 - 30mm ±0.2mm 30 - 120mm ±0.3mm ANGLES ±1°

NOTICE - These drawings, specifications, or other data (1) are, and remain the property of Amphenol corp. (2) must be returned upon request; and (3) are confidential and not to be disclosed to any person other than those to whom they are given by Amphenol Corp. The furnishing of these drawings, specifications, or other data by Amphenol Corp., or to any other person to anyone for any purpose is not to be regarded by implication or otherwise in any manner licensing, granting rights to permitting such holder or any other person to manufacture, use or sell any product, process or design, patented or otherwise, that may in any way be related to or disclosed by said drawings, specifications, or other data.

MATERIAL	
REFERENCE	EAR # 1932 AND
CONFIGURATION LEVEL:	Released
FINISH	

DRAWN	K.LI	DATE	19-Feb-10
ENGINEER	G.ANTONINI	DATE	25-Aug-04
APPROVED	S.HSIEH	DATE	19-Feb-10
CAD FILE	Root Folder/QMA/930-159J-51S		

TITLE	QMA PCB JACK EDGE MOUNT, THROUGH HOLE		
SCALE:	6.0:1.0	SHEET	2 OF 2
DWG SIZE	B	REV	B

Amphenol RF	
Danbury CT USA, Tainan, Taiwan, Shenzhen, China www.amphenolrf.com	
DRAWING NO. 930-159J-51S	
ITEM NO. 930-159J-51S	
PART NO. 930-159J-51S	