

## Consumer Low Power Wireless Transmitter Controller

### Features

- Low power (5 W) solution for Wireless Power Consortium (WPC) compliant transmitter design
- Conforms to the latest version low power WPC specifications
- Supports wide DC input voltage range starting from 4.2 V, typically 5 V, 12 V and 19 V
- Integrated digital demodulation on chip
- Supports all types of receiver modulation strategies (AC capacitor, AC resistor and DC resistor)
- Supports Foreign Object Detection (FOD)
- Super low standby power by Freescale Touch technology
- Supports any low power consumer power transmitter solutions using frequency and duty cycle control, or rail voltage control or phase shift control
- LED & buzzer for system status indication
- Over-voltage/current/temperature protection
- Supports CAN/IIC/SCI/SPI interfaces
- Software based solution to provide maximum design freedom and product differentiation
- FreeMASTER GUI tool to enable configuration, calibration and debugging

### Applications

- Low Power Wireless Power Transmitter  
Any lower power consumer power transmitter solution with frequency & duty cycle control, or rail voltage control, or phase-shift control (WPC A/B types or customer properties)

### Overview Description

The WCT1101 is a wireless power transmitter controller that integrates all required functions for WPC “Qi” compliant wireless power transmitter design. It’s an intelligent device to work with Freescale touch sensing technology or use periodically analog PING (configurable by user) to detect a mobile device for charging while gaining super low standby power. Once the mobile device is detected, the WCT1101 controls the power transfer by adjusting the operation frequency and duty cycle, or rail voltage, or phase shift of power stage according to message packets sent by mobile device.

To maximize the design freedom and product differentiation, WCT1101 supports any low power consumer power transmitter design (WPC A/B types or customization) using frequency and duty cycle control, or rail voltage control or phase shift control by software based solution. Besides, easy-to-use FreeMASTER GUI tool with configuration, calibration and debugging functions provides user-friendly design experience and speed time-to-market.

The WCT1101 includes digital demodulation module to reduce external components, over-voltage/current/temperature protection, FOD method to protect from overheating by misplaced metallic foreign objects and general CAN/IIC/SCI/SPI interfaces for external communication purpose. It also handles any abnormal condition and operational status, and provides comprehensive indicator outputs for robust system design.

### Wireless Charging System Functional Diagram

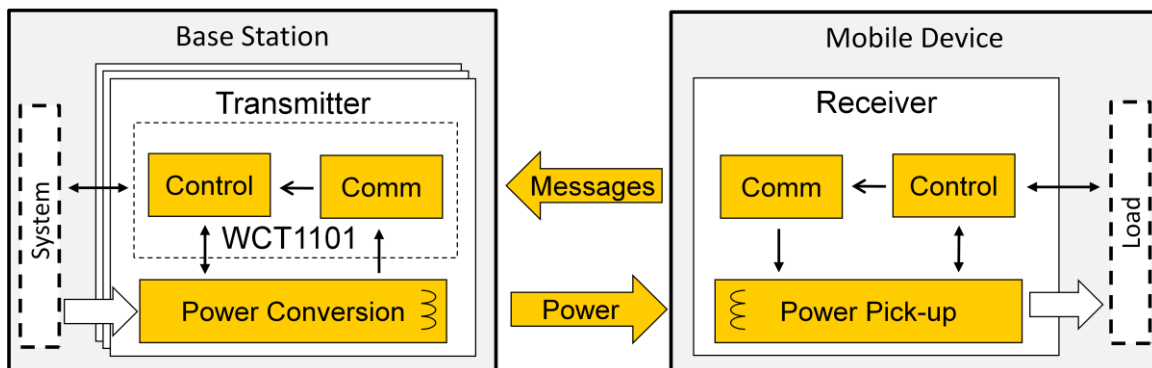

## Contents

<b>1</b>	<b>Absolute Maximum Ratings .....</b>	<b>4</b>
1.1	Electrical Operating Ratings .....	4
1.2	Thermal Handling Ratings .....	5
1.3	ESD Handling Ratings .....	5
1.4	Moisture Handling Ratings .....	5
<b>2</b>	<b>Electrical Characteristics .....</b>	<b>5</b>
2.1	General Characteristics .....	5
2.2	Device Characteristics .....	8
2.3	Thermal Operating Characteristics .....	17
<b>3</b>	<b>Typical Performance Characteristics .....</b>	<b>18</b>
3.1	System Efficiency .....	18
3.2	Standby Power .....	18
3.3	Digital Demodulation .....	18
3.4	Foreign Object Detection .....	18
3.5	Dynamic Input Power Limit .....	19
<b>4</b>	<b>Device Information .....</b>	<b>19</b>
4.1	Functional Block Diagram .....	19
4.2	Product Features Overview .....	20
4.3	Pinout Diagram .....	21
4.4	Pin Function Description .....	22

---

4.5	Ordering Information .....	31
4.6	Package Outline Drawing .....	31
<b>5</b>	<b>Software Library .....</b>	<b>31</b>
5.1	Memory Map .....	32
5.2	Software Library and API Description.....	32
<b>6</b>	<b>Design Considerations .....</b>	<b>32</b>
6.1	Electrical Design Considerations.....	32
6.2	PCB Layout Considerations.....	33
6.3	Thermal Design Considerations.....	34
<b>7</b>	<b>References and Links .....</b>	<b>34</b>
7.1	References .....	34
7.2	Useful Links.....	34

# 1 Absolute Maximum Ratings

## 1.1 Electrical Operating Ratings

**Table 1. Absolute Maximum Electrical Ratings ( $V_{SS} = 0\text{ V}$ ,  $V_{SSA} = 0\text{ V}$ )**

Characteristic	Symbol	Notes <sup>1</sup>	Min.	Max.	Unit
Supply Voltage Range	$V_{DD}$		-0.3	4.0	V
Analog Supply Voltage Range	$V_{DDA}$		-0.3	4.0	V
ADC High Voltage Reference	$V_{REFHx}$		-0.3	4.0	V
Voltage difference $V_{DD}$ to $V_{DDA}$	$\Delta V_{DD}$		-0.3	0.3	V
Voltage difference $V_{SS}$ to $V_{SSA}$	$\Delta V_{SS}$		-0.3	0.3	V
Digital Input Voltage Range	$V_{IN}$	Pin Group 1	-0.3	5.5	V
$\overline{\text{RESET}}$ Input Voltage Range	$V_{IN\_RESET}$	Pin Group 2	-0.3	4.0	V
Oscillator Input Voltage Range	$V_{OSC}$	Pin Group 4	-0.4	4.0	V
Analog Input Voltage Range	$V_{INA}$	Pin Group 3	-0.3	4.0	V
Input clamp current, per pin ( $V_{IN} < V_{SS} - 0.3\text{ V}$ ) <sup>2,3</sup>	$V_{IC}$		-	-5.0	mA
Output clamp current, per pin <sup>4</sup>	$V_{OC}$		-	$\pm 20.0$	mA
Contiguous pin DC injection current—regional limit sum of 16 contiguous pins	$I_{Icont}$		-25	25	mA
Output Voltage Range (normal push-pull mode)	$V_{OUT}$	Pin Group 1,2	-0.3	4.0	V
Output Voltage Range (open drain mode)	$V_{OUTOD}$	Pin Group 1	-0.3	5.5	V
$\overline{\text{RESET}}$ Output Voltage Range	$V_{OUTOD\_RESET}$	Pin Group 2	-0.3	4.0	V
DAC Output Voltage Range	$V_{OUT\_DAC}$	Pin Group 5	-0.3	4.0	V
Ambient Temperature	$T_A$		-40	85	°C
Storage Temperature Range	$T_{STG}$		-55	150	°C

- Default Mode:
  - Pin Group 1: GPIO, TDI, TDO, TMS, TCK
  - Pin Group 2:  $\overline{\text{RESET}}$
  - Pin Group 3: ADC and Comparator Analog Inputs
  - Pin Group 4: XTAL, EXTAL
  - Pin Group 5: DAC analog output
- Continuous clamp current.
- All 5 volt tolerant digital I/O pins are internally clamped to  $V_{SS}$  through an ESD protection diode. There is no diode connection to  $V_{DD}$ . If  $V_{IN}$  greater than  $V_{DIO\_MIN}$  ( $= V_{SS} - 0.3\text{ V}$ ) is observed, then there is no need to provide current limiting resistors at the pads. If this limit cannot be observed, then a current limiting resistor is required.
- I/O is configured as push-pull mode.

## 1.2 Thermal Handling Ratings

**Table 2. Thermal Handling Ratings**

Symbol	Description	Min.	Max.	Unit	Notes
T <sub>STG</sub>	Storage temperature	-55	150	°C	1
T <sub>SDR</sub>	Solder temperature, lead-free	-	260	°C	2

1. Determined according to JEDEC Standard JESD22-A103, *High Temperature Storage Life*.
2. Determined according to IPC/JEDEC Standard J-STD-020, *Moisture/Reflow Sensitivity Classification for Nonhermetic Solid State Surface Mount Devices*.

## 1.3 ESD Handling Ratings

**Table 3. ESD Handling Ratings**

Characteristic <sup>1</sup>	Min.	Max.	Unit
ESD for Human Body Model (HBM)	-2000	+2000	V
ESD for Machine Model (MM)	-200	+200	V
ESD for Charge Device Model (CDM)	-500	+500	V
Latch-up current at TA= 85°C (I <sub>LAT</sub> )	-100	+100	mA

1. Parameter is achieved by design characterization on a small sample size from typical devices under typical conditions unless otherwise noted.

## 1.4 Moisture Handling Ratings

**Table 4. Moisture Handling Ratings**

Symbol	Description	Min.	Max.	Unit	Notes
MSL	Moisture sensitivity level	-	3	-	1

1. Determined according to IPC/JEDEC Standard J-STD-020, *Moisture/Reflow Sensitivity Classification for Nonhermetic Solid State Surface Mount Devices*.

## 2 Electrical Characteristics

### 2.1 General Characteristics

**Table 5. General Electrical Characteristics**

Recommended Operating Conditions (V <sub>REFLx</sub> = 0 V, V <sub>SSA</sub> = 0 V, V <sub>SS</sub> = 0 V)							
Characteristic	Symbol	Notes	Min.	Typ.	Max.	Unit	Test Conditions
Supply Voltage <sup>2</sup>	V <sub>DD</sub> , V <sub>DDA</sub>		2.7	3.3	3.6	V	-

ADC (Cyclic) Reference Voltage High	$V_{REFHA}$ $V_{REFHB}$		3.0		$V_{DDA}$	V	-
Voltage difference $V_{DD}$ to $V_{DDA}$	$\Delta V_{DD}$		-0.1	0	0.1	V	-
Voltage difference $V_{SS}$ to $V_{SSA}$	$\Delta V_{SS}$		-0.1	0	0.1	V	-
Input Voltage High (digital inputs)	$V_{IH}$	1 (Pin Group 1)	$0.7 \times V_{DD}$		5.5	V	-
$\overline{RESET}$ Voltage High	$V_{IH\_RESET}$	1 (Pin Group 2)	$0.7 \times V_{DD}$	-	$V_{DD}$	V	-
Input Voltage Low (digital inputs)	$V_{IL}$	1 (Pin Group 1,2)			$0.35 \times V_{DD}$	V	-
Oscillator Input Voltage High XTAL driven by an external clock source	$V_{IHOSC}$	1 (Pin Group 4)	2.0		$V_{DD} + 0.3$	V	-
Oscillator Input Voltage Low	$V_{ILOSC}$	1 (Pin Group 4)	-0.3		0.8	V	-
Output Source Current High (at $V_{OH}$ min.) <sup>3,4</sup> • Programmed for low drive strength • Programmed for high drive strength	$I_{OH}$	1 (Pin Group 1) 1 (Pin Group 1)	- -		-2 -9	mA	-
Output Source Current Low (at $V_{OL}$ max.) <sup>3,4</sup> • Programmed for low drive strength • Programmed for high drive strength	$I_{OL}$	1 (Pin Group 1,2) 1 (Pin Group 1,2)	- -		2 9	mA	-
Output Voltage High	$V_{OH}$	1 (Pin Group 1)	$V_{DD} - 0.5$	-	-	V	$I_{OH} = I_{OHmax}$
Output Voltage Low	$V_{OL}$	1 (Pin Group 1,2)	-	-	0.5	V	$I_{OL} = I_{OLmax}$
Digital Input Current High pull-up enabled or disabled	$I_{IH}$	1 (Pin Group 1) 1 (Pin Group 2)	-	0	+/-2.5	$\mu A$	$V_{IN} = 2.4 V$ to 5.5 V $V_{IN} = 2.4 V$ to $V_{DD}$
Comparator Input Current High	$I_{IHC}$	1 (Pin Group 3)		0	+/-2	$\mu A$	$V_{IN} = V_{DDA}$
Oscillator Input Current High	$I_{IHOSC}$	1 (Pin Group 4)	-	0	+/-2	$\mu A$	$V_{IN} = V_{DDA}$
Internal Pull-Up Resistance	$R_{Pull-Up}$		20	-	50	k $\Omega$	-
Internal Pull-Down Resistance	$R_{Pull-Down}$		20	-	50	k $\Omega$	-

Comparator Input Current Low	$I_{ILC}$	1 (Pin Group 3)	-	0	+/-2	$\mu\text{A}$	$V_{IN} = 0\text{V}$
Oscillator Input Current Low	$I_{ILOSC}$	1 (Pin Group 4)	-	0	+/-2	$\mu\text{A}$	$V_{IN} = 0\text{V}$
DAC Output Voltage Range	$V_{DAC}$	1 (Pin Group 5)	$V_{SSA} + 0.04$	-	$V_{DDA} - 0.04$	V	$R_{LD} = 3\text{ k}\Omega$ , $C_{LD} = 400\text{ pF}$
Output Current <sup>1</sup> High Impedance State	$I_{OZ}$	1 (Pin Group 1,2)	-	0	+/-1	$\mu\text{A}$	-
Schmitt Trigger Input Hysteresis	$V_{HYS}$	1 (Pin Group 1,2)	$0.06 \times V_{DD}$	-	-	V	-
Input capacitance	$C_{IN}$		-	10	-	pF	-
Output capacitance	$C_{OUT}$		-	10	-	pF	-
GPIO pin interrupt pulse width <sup>5</sup>	$T_{INT\_Pulse}$	6	1.5	-	-	Bus clock	-
Port rise and fall time (high drive strength). Slew disabled.	$T_{Port\_H\_DIS}$	7	5.5	-	15.1	ns	$2.7 \leq V_{DD} \leq 3.6\text{ V}$
Port rise and fall time (high drive strength). Slew enabled.	$T_{Port\_H\_EN}$	7	1.5	-	6.8	ns	$2.7 \leq V_{DD} \leq 3.6\text{ V}$
Port rise and fall time (low drive strength). Slew disabled.	$T_{Port\_L\_DIS}$	8	8.2	-	17.8	ns	$2.7 \leq V_{DD} \leq 3.6\text{ V}$
Port rise and fall time (low drive strength). Slew enabled.	$T_{Port\_L\_EN}$	8	3.2	-	9.2	ns	$2.7 \leq V_{DD} \leq 3.6\text{ V}$
Device (system and core) clock frequency	$f_{SYSCLK}$		0	-	100	MHz	-
Bus clock	$f_{BUS}$		-	-	50	MHz	-

1. Default Mode

- Pin Group 1: GPIO, TDI, TDO, TMS, TCK
- Pin Group 2:  $\overline{\text{RESET}}$
- Pin Group 3: ADC and Comparator Analog Inputs
- Pin Group 4: XTAL, EXTAL
- Pin Group 5: DAC analog output

2. ADC (Cyclic) specifications are not guaranteed when VDDA is below 3.0 V.

3. Total chip source or sink current cannot exceed 75 mA.

4. Contiguous pin DC injection current of regional limit—including sum of negative injection currents or sum of positive injection currents of 16 contiguous pins—is 25 mA.

5. Applies to a pin only when it is configured as GPIO and configured to cause an interrupt by appropriately programming GPIO<sub>n</sub>\_IPOLR and GPIO<sub>n</sub>\_IENR.

6. The greater synchronous and asynchronous timing must be met.

7. 75 pF load.

8. 15 pF load.

## 2.2 Device Characteristics

**Table 6. General Device Characteristics**

<b>Power mode Transition Behavior</b>					
<b>Symbol</b>	<b>Description</b>	<b>Min.</b>	<b>Max.</b>	<b>Unit</b>	<b>Notes</b>
T <sub>POR</sub>	After a POR event, the amount of delay from when VDD reaches 2.7 V to when the first instruction executes (over the operating temperature range).	199	225	μs	
T <sub>S2R</sub>	STOP mode to RUN mode	6.79	7.27	μs	1
T <sub>LPS2LPR</sub>	LPS mode to LPRUN mode	240.9	551	μs	2
T <sub>VLPS2VLPR</sub>	VLPS mode to VLPRUN mode	1424	1459	μs	4
T <sub>W2R</sub>	WAIT mode to RUN mode	0.57	0.62	μs	3
T <sub>LPW2LPR</sub>	LPWAIT mode to LPRUN mode	237.2	554	μs	2
T <sub>VLPW2VLPR</sub>	VLPWAIT mode to VLPRUN mode	1413	1500	μs	4
<b>Power Consumption Operating Behaviors</b>					
<b>Mode</b>	<b>Conditions</b>	<b>Max. Frequency</b>	<b>Typical at 3.3 V, 25 °C</b>		<b>Notes</b>
			<b>I<sub>DD</sub></b>	<b>I<sub>DDA</sub></b>	
RUN1	100 MHz core clock, 50 MHz peripheral clock, regulators are in full regulation, relaxation oscillator on, PLL powered on, continuous MAC instructions with fetches from program Flash, all peripheral modules enabled, TMRs and SCIs using 1× peripheral clock, NanoEdge within eFlexPWM using 2× peripheral clock, ADC/DAC (only one 12-bit DAC and all 6-bit DACs) powered on and clocked, comparator powered on, all ports configured as inputs with input low and no DC loads	100 MHz	38.1 mA	9.9 mA	



RUN2	50 MHz core and peripheral clock, regulators are in full regulation, relaxation oscillator on, PLL powered on, continuous MAC instructions with fetches from program Flash, all peripheral modules enabled, TMRs and SCIs using 1× peripheral clock, NanoEdge within eFlexPWM using 2× peripheral clock, ADC/DAC (only one 12-bit DAC and all 6-bit DACs) powered on and clocked, comparator powered on, all ports configured as inputs with input low and no DC loads	50 MHz	27.6 mA	9.9 mA	
WAIT	50 MHz core and peripheral clock, regulators are in full regulation, relaxation oscillator on, PLL powered on, core in WAIT state, all peripheral modules enabled, TMRs and SCIs using 1× clock, NanoEdge within eFlexPWM using 2× clock, ADC/DAC (one 12-bit DAC, all 6-bit DACs)/comparator powered off, all ports configured as inputs with input low and no DC loads	50 MHz	24.0 mA	-	
STOP	4 MHz core and peripheral clock, regulators are in full regulation, relaxation oscillator on, PLL powered off, core in STOP state, all peripheral module and core clocks are off, ADC/DAC/Comparator powered off, all ports configured as inputs with input low and no DC loads	4 MHz	6.3 mA	-	
LPRUN	200 kHz core and peripheral clock from relaxation oscillator's low speed clock, relaxation oscillator in standby mode, regulators are in standby, PLL disabled, repeat NOP instructions, all peripheral modules enabled, except NanoEdge within eFlexPWM and cyclic ADCs, one 12-bit DAC and all 6-bit DACs enabled, simple loop with running from platform instruction buffer, all ports configured as inputs with input low and no DC loads	2 MHz	2.8 mA	3.1 mA	
LPWAIT	200 kHz core and peripheral clock from relaxation oscillator's low speed clock, relaxation oscillator in standby mode, regulators are in standby, PLL disabled, all peripheral modules enabled, except NanoEdge within eFlexPWM and cyclic ADCs, one 12-bit DAC and all 6-bit DACs enabled, core in WAIT mode, all ports configured as inputs with input low and no DC loads	2 MHz	2.7 mA	3.1 mA	

LPSTOP	200 kHz core and peripheral clock from relaxation oscillator's low speed clock, relaxation oscillator in standby mode, regulators are in standby, PLL disabled, only PITs and COP enabled, other peripheral modules disabled and clocks gated off, core in STOP mode, all ports configured as inputs with input low and no DC loads	2 MHz	1.2 mA	-	
VLPRUN	32 kHz core and peripheral clock from a 64 kHz external clock source, oscillator in power down, all relaxation oscillators disabled, large regulator is in standby, small regulator is disabled, PLL disabled, repeat NOP instructions, all peripheral modules, except COP and EWM, disabled and clocks gated off, simple loop running from platform instruction buffer, all ports configured as inputs with input low and no DC loads	200 kHz	0.7 mA	-	
VLPWAIT	32 kHz core and peripheral clock from a 64 kHz external clock source, oscillator in power down, all relaxation oscillators disabled, large regulator is in standby, small regulator is disabled, PLL disabled, all peripheral modules, except COP, disabled and clocks gated off, core in WAIT mode, all ports configured as inputs with input low and no DC loads	200 kHz	0.7 mA	-	
VLPSTOP	32 kHz core and peripheral clock from a 64 kHz external clock source, oscillator in power down, all relaxation oscillators disabled, large regulator is in standby, small regulator is disabled, PLL disabled, all peripheral modules, except COP, disabled and clocks gated off, core in STOP mode, all ports configured as inputs with input low and no DC loads	200 kHz	0.7 mA	-	

#### Reset and Interrupt Timing

Symbol	Characteristic	Min.	Max.	Unit	Notes
$t_{RA}$	Minimum $\overline{RESET}$ Assertion Duration	16	-	ns	5
$t_{RDA}$	$\overline{RESET}$ desertion to First Address Fetch	$865 \times T_{OSC} + 8 \times T_{SYSCLK}$	-	ns	6
$t_{IF}$	Delay from Interrupt Assertion to Fetch of first instruction (exiting STOP mode)	361.3	570.9	ns	

#### PMC Low-Voltage Detection (LVD) and Power-On Reset (POR) Parameters

Symbol	Characteristic	Min.	Typ.	Max.	Unit
$V_{POR\_A}$	POR Assert Voltage <sup>7</sup>	-	2.0	-	V

V <sub>POR_R</sub>	POR Release Voltage <sup>8</sup>	-	2.7	-	V
V <sub>LVI_2p7</sub>	LVI_2p7 Threshold Voltage	-	2.73	-	V
V <sub>LVI_2p2</sub>	LVI_2p2 Threshold Voltage	-	2.23	-	V
<b>JTAG Timing</b>					
Symbol	Description	Min.	Max.	Unit	Notes
f <sub>OP</sub>	TCK frequency of operation	DC	f <sub>SYSClk</sub> /8	MHz	
t <sub>PW</sub>	TCK clock pulse width	50	-	ns	
t <sub>DS</sub>	TMS, TDI data set-up time	5	-	ns	
t <sub>DH</sub>	TMS, TDI data hold time	5	-	ns	
t <sub>DV</sub>	TCK low to TDO data valid	-	30	ns	
t <sub>TS</sub>	TCK low to TDO tri-state	-	30	ns	
<b>Regulator 1.2 V Parameters</b>					
Symbol	Characteristic	Min.	Typ.	Max.	Unit
V <sub>CAP</sub>	Output Voltage <sup>9</sup>	-	1.22	-	V
I <sub>SS</sub>	Short Circuit Current <sup>10</sup>	-	600	-	mA
T <sub>RSC</sub>	Short Circuit Tolerance (V <sub>CAP</sub> shorted to ground)	-	-	30	Mins
V <sub>REF</sub>	Reference Voltage (after trim)	-	1.21	-	V
<b>External Clock Timing</b>					
Symbol	Characteristic	Min.	Typ.	Max.	Unit
f <sub>OSC</sub>	Frequency of operation (external clock driver)	-	-	50	MHz
t <sub>PW</sub>	Clock pulse width <sup>11</sup>	8			ns
t <sub>rise</sub>	External clock input rise time <sup>12</sup>	-	-	1	ns
t <sub>fall</sub>	External clock input fall time <sup>13</sup>	-	-	1	ns
V <sub>ih</sub>	Input high voltage overdrive by an external clock	0.85×V <sub>DD</sub>	-	-	V
V <sub>il</sub>	Input low voltage overdrive by an external clock	-	-	0.3×V <sub>DD</sub>	V
<b>Phase-Locked Loop (PLL) Timing</b>					
Symbol	Characteristic	Min.	Typ.	Max.	Unit
f <sub>Ref_PLL</sub>	PLL input reference frequency <sup>14</sup>	8	8	16	MHz
f <sub>OP_PLL</sub>	PLL output frequency <sup>15</sup>	200	-	400	MHz
t <sub>Lock_PLL</sub>	PLL lock time <sup>16</sup>	35.5	-	73.2	μs
t <sub>DC_PLL</sub>	Allowed Duty Cycle of input reference	40	50	60	%

External Crystal or Resonator Specifications					
Symbol	Characteristic	Min.	Typ.	Max.	Unit
f <sub>XOSC</sub>	Frequency of operation	4	8	16	MHz
Relaxation Oscillator Electrical Specifications					
Symbol	Characteristic	Min.	Typ.	Max.	Unit
f <sub>ROSC_8M</sub>	8 MHz Output Frequency <sup>17</sup> RUN Mode	7.84	8	8.16	MHz
	• 0 °C to 85 °C	7.76	8	8.24	MHz
	• -40 °C to 85 °C	-	405	-	kHz
f <sub>ROSC_8M_Delta</sub>	8 MHz Frequency Variation over 25 °C RUN Mode	-	+/-1.5	+/-2	%
	Due to temperature	-	+/-1.5	+/-3	%
	• 0 °C to 85 °C • -40 °C to 85 °C	-	-	-	-
f <sub>ROSC_200k</sub> <sup>17</sup>	200 kHz Output Frequency <sup>18</sup> RUN Mode	194	200	206	kHz
f <sub>ROSC_200k_Delta</sub> <sup>17</sup>	200 kHz Output Frequency Variation over 25 °C <sup>18</sup> RUN Mode	-	+/-1.5	+/-2	%
	Due to temperature	-	+/-1.5	+/-3	%
	• 0 °C to 85 °C • -40 °C to 85 °C	-	-	-	-
t <sub>Stab</sub>	Stabilization Time	-	0.12	-	µs
	• 8 MHz output <sup>19</sup> • 200 kHz output <sup>20</sup>	-	10	-	µs
t <sub>DC_ROSC</sub>	Output Duty Cycle	48	50	52	%
Flash Specifications					
Symbol	Description	Min.	Typ.	Max.	Unit
t <sub>hpgm4</sub>	Longword Program high-voltage time	-	7.5	18	µs
t <sub>hversscr</sub>	Sector Erase high-voltage time <sup>21</sup>	-	13	113	ms
t <sub>hversall</sub>	Erase All high-voltage time <sup>21</sup>	-	52	452	ms
t <sub>rd1sec1k</sub>	Read 1s Section execution time (flash sector) <sup>22</sup>	-	-	60	µs
t <sub>pgmchk</sub>	Program Check execution time <sup>22</sup>	-	-	45	µs
t <sub>rdsrc</sub>	Read Resource execution time <sup>22</sup>	-	-	30	µs
t <sub>pgm4</sub>	Program Longword execution time	-	65	145	µs
t <sub>ersscr</sub>	Erase Flash Sector execution time <sup>23</sup>	-	14	114	ms

$t_{rd1all}$	Read 1s All Blocks execution time	-	-	0.9	ms
$t_{rdonce}$	Read Once execution time <sup>22</sup>	-	-	25	$\mu$ s
$t_{pgmonce}$	Program Once execution time	-	65	-	$\mu$ s
$t_{ersall}$	Erase All Blocks execution time <sup>23</sup>	-	70	575	ms
$t_{vfykey}$	Verify Backdoor Access Key execution time <sup>22</sup>	-	-	30	$\mu$ s
$t_{flashret10k}$	Data retention after up to 10 K cycles	5	50 <sup>24</sup>	-	years
$t_{flashret1k}$	Data retention after up to 1 K cycles	20	100 <sup>24</sup>	-	years
$n_{flashcyc}$	Cycling endurance <sup>25</sup>	10 K	50 K <sup>24</sup>	-	cycles

### 12-bit Cyclic ADC Electrical Specifications

Symbol	Characteristic	Min.	Typ.	Max.	Unit
$V_{DDA}$	Supply voltage <sup>26</sup>	3.0	3.3	3.6	V
$V_{REFHX}$	$V_{REFH}$ supply voltage <sup>27</sup>	$V_{DDA} - 0.6$		$V_{DDA}$	V
$f_{ADCCLK}$	ADC conversion clock <sup>28</sup>	0.1	-	10	MHz
$R_{ADC}$	Conversion range <sup>29</sup> <ul style="list-style-type: none"> <li>Fully differential</li> <li>Single-ended/unipolar</li> </ul>	$-(V_{REFH} - V_{REFL})$ $V_{REFL}$	- -	$V_{REFH} - V_{REFL}$ $V_{REFH}$	V V
$V_{ADCI}$	Input voltage range (per input) <sup>30</sup> <ul style="list-style-type: none"> <li>External Reference</li> <li>Internal Reference</li> </ul>	$V_{REFL}$ $V_{SSA}$	- -	$V_{REFH}$ $V_{DDA}$	V V
$t_{ADC}$	Conversion time	-	8	-	$t_{ADCCLK}$
$t_{ADCPU}$	ADC power-up time (from <code>adc_pdn</code> )	-	13	-	$t_{ADCCLK}$
$I_{ADCRUN}$	ADC RUN current (per ADC block)	-	1.8	-	mA
$I_{ADPWRDWN}$	ADC power down current ( <code>adc_pdn</code> enabled)	-	0.1	-	$\mu$ A
$I_{VREFH}$	$V_{REFH}$ current (in external mode)	-	190	225	$\mu$ A
$INL_{ADC}$	Integral non-linearity <sup>31</sup>	-	+/- 1.5	+/- 2.2	LSB <sup>32</sup>
$DNL_{ADC}$	Differential non-linearity <sup>31</sup>	-	+/- 0.5	+/- 0.8	LSB <sup>32</sup>
$V_{OFFSET}$	Offset <sup>33</sup> <ul style="list-style-type: none"> <li>Fully differential</li> <li>Single ended/Unipolar</li> </ul>	- -	+/- 8 +/- 12	- -	mV mV
$E_{GAIN}$	Gain Error	-	0.996 to 1.004	0.99 to 1.101	-
$ENOB$	Effective number of bits	-	10.6	-	bits
$I_{INJ}$	Input injection current <sup>34</sup>	-	-	+/-3	mA
$C_{ADCI}$	Input sampling capacitance	-	4.8	-	pF

### 12-bit DAC Electrical Specifications

Symbol	Characteristic	Min.	Typ.	Max.	Unit
--------	----------------	------	------	------	------

$t_{SETTLE}$	Settling time <sup>35</sup> under $R_{LD} = 3\text{ k}\Omega$ , $C_{LD} = 400\text{ pF}$	-	1	-	$\mu\text{s}$
$t_{DACPU}$	DAC power-up time (from PWRDWN release to valid DACOUT)	-	-	11	$\mu\text{s}$
$INL_{DAC}$	Integral non-linearity <sup>37</sup>	-	+/- 3	+/- 4	LSB <sup>36</sup>
$DNL_{DAC}$	Differential non-linearity <sup>37</sup>	-	+/- 0.8	+/- 0.9	LSB <sup>36</sup>
$MON_{DAC}$	Monotonicity (> 6 sigma monotonicity, < 3.4 ppm non-monotonicity)	Guaranteed			-
$V_{OFFSET}$	Offset error <sup>37</sup> (5% to 95% of full range)	-	+/- 25	+/- 43	mV
$E_{GAIN}$	Gain error <sup>37</sup> (5% to 95% of full range)	-	+/- 0.5	+/- 1.5	%
$V_{OUT}$	Output voltage range	$V_{SSA} + 0.04$	-	$V_{DDA} - 0.04$	V
SNR	Signal-to-noise ratio	-	85	-	dB
ENOB	Effective number of bits	-	11	-	bits

#### Comparator and 6-bit DAC Electrical Specifications

Symbol	Description	Min.	Typ.	Max.	Unit
$V_{DD}$	Supply voltage	2.7	-	3.6	V
$I_{DDHS}$	Supply current, High-speed mode(EN=1, PMODE=1)	-	300	-	$\mu\text{A}$
$I_{DDL S}$	Supply current, Low-speed mode(EN=1, PMODE=0)	-	36	-	$\mu\text{A}$
$V_{AIN}$	Analog input voltage	$V_{SS}$	-	$V_{DD}$	V
$V_{AIO}$	Analog input offset voltage	-	-	20	mV
$V_H$	Analog comparator hysteresis <sup>38</sup> <ul style="list-style-type: none"> <li>• CR0[HYSTCTR]=00</li> <li>• CR0[HYSTCTR]=01</li> <li>• CR0[HYSTCTR]=10</li> <li>• CR0[HYSTCTR]=11</li> </ul>	-	5	13	mV
		-	25	48	mV
		-	55	105	mV
		-	80	148	mV
$V_{CMPOH}$	Output high	$V_{DD} - 0.5$	-	-	V
$V_{CMPOI}$	Output low	-	-	0.5	V
$t_{DHS}$	Propagation delay, high-speed mode(EN=1, PMODE=1) <sup>39</sup>	-	25	50	ns
$t_{DLS}$	Propagation delay, low-speed mode(EN=1, PMODE=0) <sup>39</sup>	-	60	200	ns
$t_{DInit}$	Analog comparator initialization delay <sup>40</sup>	-	40	-	$\mu\text{s}$
$I_{DAC6b}$	6-bit DAC current adder (enabled)	-	7	-	$\mu\text{A}$
$R_{DAC6b}$	6-bit DAC reference inputs	$V_{DDA}$	-	$V_{DD}$	V

INL <sub>DAC6b</sub>	6-bit DAC integral non-linearity	-0.5	-	0.5	LSB <sup>41</sup>	
DNL <sub>DAC6b</sub>	6-bit DAC differential non-linearity	-0.3	-	0.3	LSB <sup>41</sup>	
<b>eFlexPWM Timing Parameters</b>						
Symbol	Characteristic	Min.	Typ.	Max.	Unit	
f <sub>PWM</sub>	PWM clock frequency	-	100	-	MHz	
S <sub>PWMNEP</sub>	NanoEdge Placement (NEP) step size <sup>42,43</sup>	-	312	-	ps	
t <sub>DFLT</sub>	Delay for fault input activating to PWM output deactivated	1	-	-	ns	
t <sub>PWMPU</sub>	Power-up time <sup>44</sup>	-	25	-	μs	
<b>Quad Timer Timing</b>						
Symbol	Characteristic	Min.	Max.	Unit	Notes	
P <sub>IN</sub>	Timer input period	2T <sub>timer</sub> + 6	-	ns	45	
P <sub>INHL</sub>	Timer input high/low period	1T <sub>timer</sub> + 3	-	ns	45	
P <sub>OUT</sub>	Timer output period	2T <sub>timer</sub> - 2	-	ns	45	
P <sub>OUTH</sub>	Timer output high/low period	1T <sub>timer</sub> - 2	-	ns	45	
<b>QSPI Timing</b>						
Symbol	Characteristic	Min.		Max.		Unit
		Master	Slave	Master	Slave	
t <sub>C</sub>	Cycle time	60	60	-	-	ns
t <sub>ELD</sub>	Enable lead time	-	20	-	-	ns
t <sub>ELG</sub>	Enable lag time	-	20	-	-	ns
t <sub>CH</sub>	Clock (SCLK) high time	28	28	-	-	ns
t <sub>CL</sub>	Clock (SCLK) low time	28	28	-	-	ns
t <sub>DS</sub>	Data set-up time required for inputs	20	1	-	-	ns
t <sub>DH</sub>	Data hold time required for inputs	1	3	-	-	ns
t <sub>A</sub>	Access time (time to data active from high-impedance state)		5		-	ns
t <sub>D</sub>	Disable time (hold time to high-impedance state)		5		-	ns
t <sub>DV</sub>	Data valid for outputs	-	-			ns
t <sub>DI</sub>	Data invalid	0	0	-	-	ns
t <sub>R</sub>	Rise time	-	-	1	1	ns
t <sub>F</sub>	Fall time	-	-	1	1	ns
<b>QSCI Timing</b>						
Symbol	Characteristic	Min.	Max.	Unit	Notes	
BR <sub>SCI</sub>	Baud rate	-	(f <sub>MAX_SCI</sub> / 16)	Mbit/s	46	
PW <sub>RXD</sub>	RXD pulse width	0.965/BR <sub>SCI</sub>	1.04/BR <sub>SCI</sub>	ns		

PW <sub>TXD</sub>	TXD pulse width	0.965/BR <sub>SCI</sub>	1.04/BR <sub>SCI</sub>	ns			
<b>CAN Timing</b>							
<b>Symbol</b>	<b>Characteristic</b>	<b>Min.</b>	<b>Max.</b>	<b>Unit</b>	<b>Notes</b>		
BR <sub>CAN</sub>	Baud rate	-	1	Mbit/s			
T <sub>WAKEUP</sub>	CAN Wakeup dominant pulse filtered	-	1.5	µs			
T <sub>WAKEUP</sub>	CAN Wakeup dominant pulse pass	5	-	µs			
<b>IIC Timing</b>							
<b>Symbol</b>	<b>Characteristic</b>	<b>Min.</b>		<b>Max.</b>		<b>Unit</b>	<b>Notes</b>
		<b>Min.</b>	<b>Max.</b>	<b>Min.</b>	<b>Max.</b>		
f <sub>SCL</sub>	SCL clock frequency	0	100	0	400	kHz	
t <sub>HD_STA</sub>	Hold time (repeated) START condition. After this period, the first clock pulse is generated.	4	-	0.6	-	µs	
t <sub>SCL_LOW</sub>	LOW period of the SCL clock	4.7	-	1.3	-	µs	
t <sub>SCL_HIGH</sub>	HIGH period of the SCL clock	4	-	0.6	-	µs	
t <sub>SU_STA</sub>	Set-up time for a repeated START condition	4.7	-	0.6	-	µs	
t <sub>HD_DAT</sub>	Data hold time for IIC bus devices	0 <sup>47</sup>	3.45 <sup>48</sup>	0 <sup>49</sup>	0.9 <sup>47</sup>	µs	
t <sub>SU_DAT</sub>	Data set-up time	250 <sup>50</sup>	-	100 <sup>51</sup>	-	ns	48
t <sub>r</sub>	Rise time of SDA and SCL signals	-	1000	20 + 0.1C <sub>b</sub>	300	ns	52
t <sub>f</sub>	Fall time of SDA and SCL signals	-	300	20 + 0.1C <sub>b</sub>	300	ns	51
t <sub>SU_STOP</sub>	Set-up time for STOP condition	4	-	0.6	-	µs	
t <sub>BUS_Free</sub>	Bus free time between STOP and START condition	4.7	-	1.3	-	µs	
t <sub>SP</sub>	Pulse width of spikes that must be suppressed by the input filter	N/A	N/A	0	50	ns	

- CPU clock = 4 MHz and System running from 8 MHz IRC Applicable to all wakeup times: Wakeup times (in 1,2,3,4) are measured from GPIO toggle for wakeup till GPIO toggle at the wakeup interrupt subroutine from respective stop/wait mode.
- CPU clock = 200 kHz and 8 MHz IRC on standby. Exit via interrupt on Port C GPIO.
- Clock configuration: CPU and system clocks= 100 MHz; Bus Clock = 50 MHz. Exit via an interrupt on PortC GPIO.
- Using 64 KHz external clock; CPU Clock = 32 KHz. Exit via an interrupt on PortC GPIO.
- If the **RESET** pin filter is enabled by setting the RST\_FLT bit in the SIM\_CTRL register to 1, the minimum pulse assertion must be greater than 21 ns.
- TOSC means oscillator clock cycle; TSYCLK means system clock cycle.
- During 3.3 V VDD power supply ramp down.
- During 3.3 V VDD power supply ramp up (gated by LVI\_2p7).
- Value is after trim.
- Guaranteed by design.
- The chip may not function if the high or low pulse width is smaller than 6.25 ns.
- External clock input rise time is measured from 10% to 90%.
- External clock input fall time is measured from 90% to 10%.
- An externally supplied reference clock should be as free as possible from any phase jitter for the PLL to work correctly. The PLL is optimized for 8 MHz input.
- The frequency of the core system clock cannot exceed 100 MHz. If the NanoEdge PWM is available, the PLL output must be set to 400 MHz.



16. This is the time required after the PLL is enabled to ensure reliable operation.
17. Frequency after application of 8 MHz trimmed.
18. Frequency after application of 200 kHz trimmed.
19. Standby to run mode transition.
20. Power down to run mode transition.
21. Maximum time based on expectations at cycling end-of-life.
22. Assumes 25 MHz flash clock frequency.
23. Maximum times for erase parameters based on expectations at cycling end-of-life.
24. Typical data retention values are based on measured response accelerated at high temperature and derated to a constant 25°C use profile. Engineering Bulletin EB618 does not apply to this technology. Typical endurance defined in Engineering Bulletin EB619.
25. Cycling endurance represents number of program/erase cycles at  $-40^{\circ}\text{C} \leq T_j \leq 125^{\circ}\text{C}$ .
26. The ADC functions up to  $V_{DDA} = 2.7\text{ V}$ . When  $V_{DDA}$  is below 3.0 V, ADC specifications are not guaranteed.
27. When the input is at the  $V_{REFL}$  level, the resulting output will be all zeros (hex 000), plus any error contribution due to offset and gain error. When the input is at the  $V_{REFH}$  level the output will be all ones (hex FFF), minus any error contribution due to offset and gain error.
28. ADC clock duty cycle is 45% ~ 55%.
29. Conversion range is defined for x1 gain setting. For x2 and x4 the range is 1/2 and 1/4, respectively.
30. In unipolar mode, positive input must be ensured to be always greater than negative input.
31.  $INL_{ADC}/DNL_{ADC}$  is measured from  $V_{ADCIN} = V_{REFL}$  to  $V_{ADCIN} = V_{REFH}$  using Histogram method at x1 gain setting.
32. Least Significant Bit = 0.806 mV at 3.3 V  $V_{DDA}$ , x1 gain setting.
33. Any off-channel with 50 kHz full-scale input to the channel being sampled with DC input (isolation crosstalk).
34. The current that can be injected into or sourced from an unselected ADC input without affecting the performance of the ADC.
35. Settling time is swing range from  $V_{SSA}$  to  $V_{DDA}$ .
36.  $LSB = 0.806\text{ mV}$ .
37. No guaranteed specification within 5% of  $V_{DDA}$  or  $V_{SSA}$ .
38. Typical hysteresis is measured with input voltage range limited to 0.7 to  $V_{DD}-0.7\text{ V}$ .
39. Signal swing is 100 mV.
40. Comparator initialization delay is defined as the time between software writes to change control inputs (Writes to  $DACEN$ ,  $VRSEL$ ,  $PSEL$ ,  $MSEL$ ,  $VOSEL$ ) and the comparator output settling to a stable level.
41.  $1\text{ LSB} = V_{reference}/64$ .
42. Reference IPbus clock of 100 MHz in NanoEdge Placement mode.
43. Temperature and voltage variations do not affect NanoEdge Placement step size.
44. Powerdown to NanoEdge mode transition.
45.  $T_{timer} = \text{Timer input clock cycle}$ . For 100 MHz operation,  $T_{timer} = 10\text{ ns}$ .
46.  $f_{MAX\_SCI}$  is the frequency of operation of the SCI clock in MHz, which can be selected as the bus clock or 2x bus clock for the device.
47. The master mode IIC deasserts ACK of an address byte simultaneously with the falling edge of SCL. If no slaves acknowledge this address byte, then a negative hold time can result, depending on the edge rates of the SDA and SCL lines.
48. The maximum  $t_{HD\_DAT}$  must be met only if the device does not stretch the LOW period ( $t_{SCL\_LOW}$ ) of the SCL signal.
49. Input signal Slew = 10 ns and Output Load = 50 pF
50. Set-up time in slave-transmitter mode is 1 IPbus clock period, if the TX FIFO is empty.
51. A Fast mode IIC bus device can be used in a Standard mode IIC bus system, but the requirement  $t_{SU\_DAT} \geq 250\text{ ns}$  must then be met. This is automatically the case if the device does not stretch the LOW period of the SCL signal. If such a device does stretch the LOW period of the SCL signal, then it must output the next data bit to the SDA line  $t_{max} + t_{SU\_DAT} = 1000 + 250 = 1250\text{ ns}$  (according to the Standard mode IIC bus specification) before the SCL line is released.
52.  $C_b$  = total capacitance of the one bus line in pF.

## 2.3 Thermal Operating Characteristics

**Table 7. General Thermal Characteristics**

Symbol	Description	Min.	Max.	Unit
$T_J$	Die junction temperature	-40	125	$^{\circ}\text{C}$
$T_A$	Ambient temperature	-40	85	$^{\circ}\text{C}$

## 3 Typical Performance Characteristics

### 3.1 System Efficiency

The typical maximum system efficiency (receiver output power vs. transmitter input power) on Freescale WCT1101 based transmitter solutions can usually reach 70 plus percentage. Of course, the detailed number depends on the specific solution type. For example, Freescale A11 reference solution has more than 75% system efficiency with bq51013AEVM-764 receiver module.

**Note:** Power components are the main factor to determine the system efficiency, such as drivers and MOSFETs.

### 3.2 Standby Power

The purpose of the standby mode of operation is to reduce the power consumption of a wireless power transfer system when power transfer is not required. There are two ways to enter standby mode. The first is when the transmitter doesn't detect the presence of a valid receiver. The second is when the receiver sends only an End Power Transfer Packet. In standby mode, the transmitter only monitors if a receiver is placed on the active charging area of the transmitter or removed there from.

It is recommended that the transmitter's power consumption in standby mode meets the relative regional regulations especially for "No-load power consumption".

In Freescale A11 reference design solution:

- Transmitter power consumption in standby mode with Analog PING technology: < 12 mA (60 mW with 5 V DC input)
- Transmitter power consumption in standby mode with Touch Sensor technology: < 5 mA (25 mW with 5 V DC input)

### 3.3 Digital Demodulation

To optimize system BOM cost, WCT1101 solution employs digital demodulation algorithm to communicate with receiver. This method can achieve high performance, low cost, and very simple coil signal sensing circuit with less component number.

### 3.4 Foreign Object Detection

WCT1101 solution employs flexible, intelligent and easy-to-use FOD algorithm to ensure accurate foreign metal objects detection. With Freescale FreeMASTER GUI tool, FOD algorithm can be easily calibrated to get accurate power loss information especially for very sensitive foreign objects.

---

### 3.5 Dynamic Input Power Limit

When the transmitter is powered by a limited power supply, such as USB power, WCT1101 can limit the transmitter output power and provide necessary margin relative to the input power supply capability. By monitoring the input voltage and input current of the transmitter, when it drops to a specified level and still positive Control Error Packet (CEP) is received, WCT1101 will stop increasing power output and control transmitter operation in input power limit status. Users can know the system is in DIPL control mode by LED indication, LED1 and LED2 will be in fast blinking mode when input power is limited. WCT1101 will exit DIPL control mode and return to normal PID control mode if a negative Control Error Packet (CEP) is received to reduce output power. The input voltage level for DIPL control can be configured in the WCT1101 example project.

## 4 Device Information

### 4.1 Functional Block Diagram

This functional block diagram just shows the functional block pin assignment information of MWCT1101CLH. For the detailed pin multiplexing information, please see Section 4.4 of “Pin Function Description”.

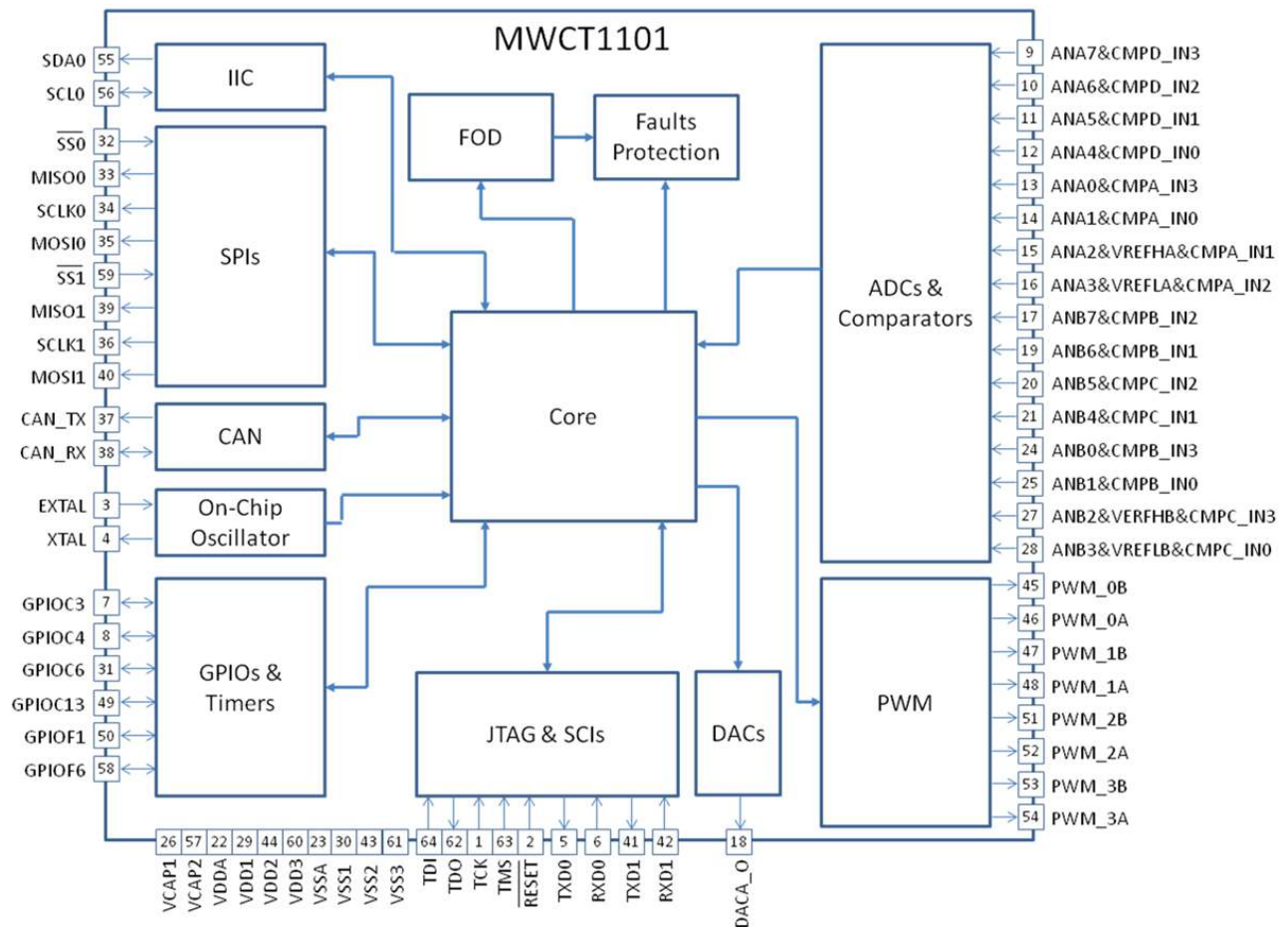

Figure 3. MWCT1101CLH Function Block Diagram

## 4.2 Product Features Overview

The following table highlights the main on-chip resource features of MWCT1101 device.

Table 8. Product Features Overview

Part	WCT1101
Maximum Core/Bus Clock (MHz)	100/50
Maximum Fully Run Current Consumption (mA)	38.1 ( $V_{DD}$ ) + 9.9 ( $V_{DDA}$ )
On-Chip Program Flash Memory Size (KB)	64
On-Chip SRAM Memory Size (KB)	8
Memory Resource Protection	Yes
Inter-Peripheral Crossbar Switches with AOI	Yes
On-Chip Relaxation Oscillator	1 (8 MHz) + 1 (200 kHz)
Windowed Computer Operating Properly	1
External Watchdog Monitor	1
Cyclic Redundancy Check	1

Periodic Interrupt Timer		2
Quad Timer		1 x 4
12-bit Cyclic ADC Channels		2 x 8
PWM Channels	High-Resolution	8
	Standard	4
12-bit DAC		2
Analog Comparator /w 6-bit REF DAC		4
DMA Channels		4
Queued Serial Communications Interface		2
Queued Serial Peripheral Interface		2
Inter-Integrated Circuit		1
Controller Area Network (MSCAN)		1
GPIO		54
Package		64 LQFP

### 4.3 Pinout Diagram

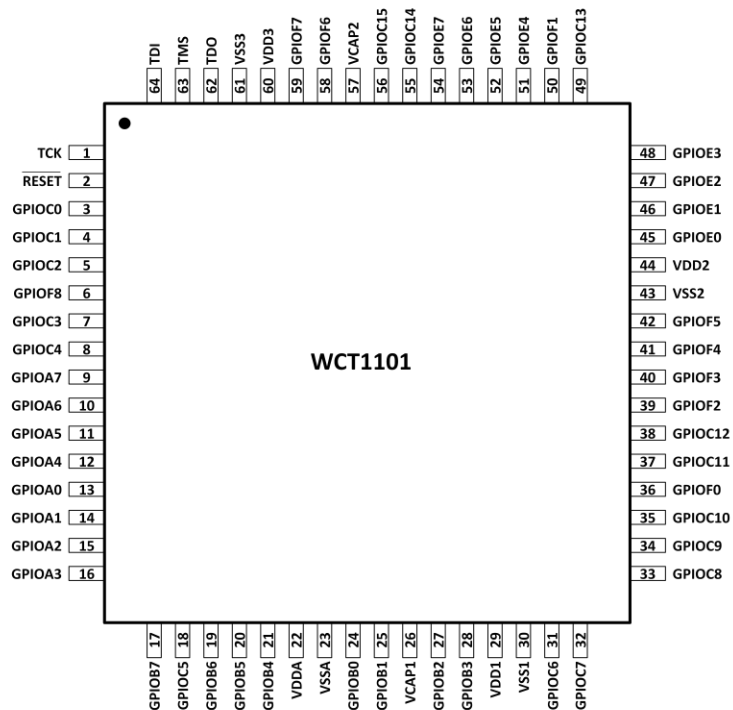

Figure 4. MWCT1101CLH Pinout Diagram

## 4.4 Pin Function Description

By default, each pin is configured for its primary function (listed first). Any alternative functionality, shown in parentheses, can be programmed through GPIO module peripheral enable registers and SIM module GPIO peripheral select registers.

**Table 9. Pin Signal Descriptions**

Signal Name	Pin No.	Multiplexing Signals	Function Description
TCK	1	GPIOD2	<p>Test Clock Input — This input pin provides a gated clock to synchronize the test logic and shift serial data to the JTAG/EOnCE port. The pin is connected internally to a pull-up resistor. A Schmitt-trigger input is used for noise immunity.</p> <p>Port D GPIO — This GPIO pin can be individually programmed as an input or output pin.</p> <p>After reset, the default state is TCK.</p>
$\overline{\text{RESET}}$	2	GPIOD4	<p><math>\overline{\text{RESET}}</math> — This input is a direct hardware reset on the processor. When <math>\overline{\text{RESET}}</math> is asserted low, the device is initialized and placed in the reset state. A Schmitt-trigger input is used for noise immunity. The internal reset signal is de-asserted synchronous with the internal clocks after a fixed number of internal clocks.</p> <p>Port D GPIO — This GPIO pin can be individually programmed as an input or output pin. If <math>\overline{\text{RESET}}</math> functionality is disabled in this mode and the chip can be reset only via POR, COP reset, or software reset.</p> <p>After reset, the default state is <math>\overline{\text{RESET}}</math>.</p>
GPIOC0	3	EXTAL/CLKIN0	<p>Port C GPIO — This GPIO pin can be individually programmed as an input or output pin.</p> <p>EXTAL — External Crystal Oscillator Input. This input connects the internal crystal oscillator input to an external crystal or ceramic resonator.</p> <p>CLKIN0 — This pin serves as an external clock input 0.</p> <p>After reset, the default state is GPIOC0.</p>
GPIOC1	4	XTAL	<p>Port C GPIO — This GPIO pin can be individually programmed as an input or output pin.</p> <p>XTAL — External Crystal Oscillator Output. This output connects the internal crystal oscillator output to an external crystal or ceramic resonator.</p> <p>After reset, the default state is GPIOC1.</p>
GPIOC2	5	TXD0/XB_OUT11/XB_IN2/CLKO0	<p>Port C GPIO — This GPIO pin can be individually programmed as an input or output pin.</p> <p>TXD0 — The SCI0 transmit data output or transmit/receive in single wire operation.</p> <p>XB_OUT11 — Crossbar module output 11.</p> <p>XB_IN2 — Crossbar module input 2.</p> <p>CLKO0 — This is a buffered clock output 0; the clock source is selected by clock out select (CLKOSEL) bits in the clock output select register (CLKOUT) of the SIM.</p>

			After reset, the default state is GPIOC2.
GPIOF8	6	RXD0/XB_OUT10/CMPD_O/PWM_2X	<p>Port F GPIO — This GPIO pin can be individually programmed as an input or output pin.</p> <p>RXD0 — The SCI0 receive data input.</p> <p>XB_OUT10 — Crossbar module output 10.</p> <p>CMPD_O — Analog comparator D output.</p> <p>PWM_2X — NanoEdge eFlexPWM sub-module 2 output X or input capture X.</p> <p>After reset, the default state is GPIOF8.</p>
GPIOC3	7	TA0/CMPA_O/RXD0/CLKIN1	<p>Port C GPIO — This GPIO pin can be individually programmed as an input or output pin.</p> <p>TA0 — Quad timer module A channel 0 input/output.</p> <p>CMPA_O — Analog comparator A output.</p> <p>RXD0 — The SCI0 receive data input.</p> <p>CLKIN1 — This pin serves as an external clock input 1.</p> <p>After reset, the default state is GPIOC3.</p>
GPIOC4	8	TA1/CMPB_O/XB_IN6/EWM_OUT	<p>Port C GPIO — This GPIO pin can be individually programmed as an input or output pin.</p> <p>TA1 — Quad timer module A channel 1 input/output.</p> <p>CMPB_O — Analog comparator B output.</p> <p>XB_IN6 — Crossbar module input 6.</p> <p>EWM_OUT — External watchdog monitor output.</p> <p>After reset, the default state is GPIOC4.</p>
GPIOA7	9	ANA7&CMPD_IN3	<p>Port A GPIO — This GPIO pin can be individually programmed as an input or output pin.</p> <p>ANA7&amp;CMPD_IN3 — Analog input to channel 7 of ADCA and input 3 of analog comparator D. When used as an analog input, the signal goes to the ANA7 and CMPD_IN3.</p> <p>After reset, the default state is GPIOA7.</p>
GPIOA6	10	ANA6&CMPD_IN2	<p>Port A GPIO — This GPIO pin can be individually programmed as an input or output pin.</p> <p>ANA6&amp;CMPD_IN2 — Analog input to channel 6 of ADCA and input 2 of analog comparator D. When used as an analog input, the signal goes to the ANA6 and CMPD_IN2.</p> <p>After reset, the default state is GPIOA6.</p>
GPIOA5	11	ANA5&CMPD_IN1	<p>Port A GPIO — This GPIO pin can be individually programmed as an input or output pin.</p> <p>ANA5&amp;CMPD_IN1 — Analog input to channel 5 of ADCA and input 1 of analog comparator D. When used as an analog input, the signal goes to the</p>

			ANA5 and CMPD_IN1. After reset, the default state is GPIOA5.
GPIOA4	12	ANA4&CMPD_IN0	Port A GPIO — This GPIO pin can be individually programmed as an input or output pin. ANA4&CMPD_IN0 — Analog input to channel 4 of ADCA and input 0 of analog comparator D. When used as an analog input, the signal goes to the ANA4 and CMPD_IN0. After reset, the default state is GPIOA4.
GPIOA0	13	ANA0&CMPA_IN3/CMPC_O	Port A GPIO — This GPIO pin can be individually programmed as an input or output pin. ANA0&CMPA_IN3 — Analog input to channel 0 of ADCA and input 3 of analog comparator A. When used as an analog input, the signal goes to the ANA0 and CMPA_IN3. CMPC_O — Analog comparator C output. After reset, the default state is GPIOA0.
GPIOA1	14	ANA1&CMPA_IN0	Port A GPIO — This GPIO pin can be individually programmed as an input or output pin. ANA1 and CMPA_IN0 — Analog input to channel 1 of ADCA and input 0 of analog comparator A. When used as an analog input, the signal goes to the ANA1 and CMPA_IN0. After reset, the default state is GPIOA1.
GPIOA2	15	ANA2&VREFHA&CMPA_IN1	Port A GPIO — This GPIO pin can be individually programmed as an input or output pin. ANA2&VREFHA&CMPA_IN1 — Analog input to channel 2 of ADCA and analog references high of ADCA and input 1 of analog comparator A. When used as an analog input, the signal goes to ANA2 and VREFHA and CMPA_IN1. ADC control register configures this input as ANA2 or VREFHA. After reset, the default state is GPIOA2.
GPIOA3	16	ANA3&VREFLA&CMPA_IN2	Port A GPIO — This GPIO pin can be individually programmed as an input or output pin. ANA3&VREFLA&CMPA_IN2 — Analog input to channel 3 of ADCA and analog references low of ADCA and input 2 of analog comparator A. When used as an analog input, the signal goes to ANA3 and VREFLA and CMPA_IN2. ADC control register configures this input as ANA3 or VREFLA. After reset, the default state is GPIOA3.
GPIOB7	17	ANB7&CMPB_IN2	Port B GPIO — This GPIO pin can be individually programmed as an input or output pin. ANB7&CMPB_IN2 — Analog input to channel 7 of ADCB and input 2 of analog comparator B. When used as an analog input, the signal goes to the ANB7 and CMPB_IN2. After reset, the default state is GPIOB7.
GPIOC5	18	DACA_O/XB_IN7	Port C GPIO — This GPIO pin can be individually programmed as an input or output pin. DACA_O — 12-bit Digital-to-Analog Converter A output.



			<p>XB_IN7 — Crossbar module input 7.</p> <p>After reset, the default state is GPIOC5.</p>
GPIOB6	19	ANB6&CMPB_IN1	<p>Port B GPIO — This GPIO pin can be individually programmed as an input or output pin.</p> <p>ANB6&amp;CMPB_IN1 — Analog input to channel 6 of ADCB and input 1 of analog comparator B. When used as an analog input, the signal goes to ANB6 and CMPB_IN1.</p> <p>After reset, the default state is GPIOB6.</p>
GPIOB5	20	ANB5&CMPC_IN2	<p>Port B GPIO — This GPIO pin can be individually programmed as an input or output pin.</p> <p>ANB5&amp;CMPC_IN2 — Analog input to channel 5 of ADCB and input 2 of analog comparator C. When used as an analog input, the signal goes to ANB5 and CMPC_IN2.</p> <p>After reset, the default state is GPIOB5.</p>
GPIOB4	21	ANB4&CMPC_IN1	<p>Port B GPIO — This GPIO pin can be individually programmed as an input or output pin.</p> <p>ANB4&amp;CMPC_IN1 — Analog input to channel 4 of ADCB and input 1 of analog comparator C. When used as an analog input, the signal goes to ANB4 and CMPC_IN1.</p> <p>After reset, the default state is GPIOB4.</p>
VDDA	22	-	Analog Power — This pin supplies 3.3 V power to the analog modules. It must be connected to a clean analog power supply.
VSSA	23	-	Analog Ground — This pin supplies an analog ground to the analog modules. It must be connected to a clean power supply.
GPIOB0	24	ANB0&CMPB_IN3	<p>Port B GPIO — This GPIO pin can be individually programmed as an input or output pin.</p> <p>ANB0&amp;CMPB_IN3 — Analog input to channel 0 of ADCB and input 3 of analog comparator B. When used as an analog input, the signal goes to ANB0 and CMPB_IN3.</p> <p>After reset, the default state is GPIOB0.</p>
GPIOB1	25	ANB1&CMPB_IN0/DACB_O	<p>Port B GPIO — This GPIO pin can be individually programmed as an input or output pin.</p> <p>ANB1&amp;CMPB_IN0 — Analog input to channel 1 of ADCB and input 0 of analog comparator B. When used as an analog input, the signal goes to ANB1 and CMPB_IN0.</p> <p>DACB_O — 12-bit Digital-to-Analog Converter B output.</p> <p>After reset, the default state is GPIOB1.</p>
VCAP1	26	-	Connect a 2.2 $\mu$ F or greater bypass capacitor between this pin and VSS to stabilize the core voltage regulator output required for proper device operation.
GPIOB2	27	ANB2&VREFHB&CMPC_IN3	<p>Port B GPIO — This GPIO pin can be individually programmed as an input or output pin.</p> <p>ANB2&amp;VREFHB&amp;CMPC_IN3 — Analog input to channel 2 of ADCB and analog references high of ADCB and input 3 of analog comparator C. When used as an analog input, the signal goes to ANB2 and VREFHB and CMPC_IN3. ADC control register configures this input as ANB2 or VREFHB.</p>

			After reset, the default state is GPIOB2.
GPIOB3	28	ANB3&VREFLB &CMPC_IN0	Port B GPIO — This GPIO pin can be individually programmed as an input or output pin.  ANB3&VREFLB&CMPC_IN0 — Analog input to channel 3 of ADCB and analog references low of ADCB and input 0 of analog comparator C. When used as an analog input, the signal goes to ANB3 and VREFLB and CMPC_IN0. ADC control register configures this input as ANB3 or VREFLB.  After reset, the default state is GPIOB3.
VDD1	29	-	I/O Power — Supplies 3.3 V power to on-chip digital module.
VSS1	30	-	I/O Ground — Provides ground on-chip digital module.
GPIOC6	31	TA2/XB_IN3/C MP_REF/SS0	Port C GPIO — This GPIO pin can be individually programmed as an input or output pin.  TA2 — Quad timer module A channel 2 input/output.  XB_IN3 — Crossbar module input 3.  CMP_REF — Input 5 of analog comparator A and B and C and D.  $\overline{SS0}$ — $\overline{SS0}$ is used in slave mode to indicate to the SPI0 module that the current transfer is to be received.  After reset, the default state is GPIOC6.
GPIOC7	32	$\overline{SS0}$ /TXD0/XB_I N8	Port C GPIO — This GPIO pin can be individually programmed as an input or output pin.  $\overline{SS0}$ — $\overline{SS0}$ is used in slave mode to indicate to the SPI0 module that the current transfer is to be received.  TXD0 — SCI0 transmit data output or transmit/receive in single wire operation.  XB_IN8 — Crossbar module input 8.  After reset, the default state is GPIOC7.
GPIOC8	33	MISO0 /RXD0/XB_IN9/ XB_OUT6	Port C GPIO — This GPIO pin can be individually programmed as an input or output pin.  MISO0 — Master in/slave out. In master mode, this pin serves as the data input. In slave mode, this pin serves as the data output. The MISO0 line of a slave device is placed in the high-impedance state if the slave device is not selected.  RXD0 — SCI0 receive data input.  XB_IN9 — Crossbar module input 9.  XB_OUT6 — Crossbar module output 6.  After reset, the default state is GPIOC8.
GPIOC9	34	SCLK0/XB_IN4/ TXD0/XB_OUT 8	Port C GPIO — This GPIO pin can be individually programmed as an input or output pin.  SCLK0 — The SPI0 serial clock. In master mode, this pin serves as an output, clocking slaved listeners. In slave mode, this pin serves as the data clock input.

			<p>XB_IN4 — Crossbar module input 4.</p> <p>TXD0 — SCI0 transmit data output or transmit/receive in single wire operation.</p> <p>XB_OUT8 — Crossbar module output 8.</p> <p>After reset, the default state is GPIOC9.</p>
GPIOC10	35	MOSI0 /XB_IN5/MISO0 /XB_OUT9	<p>Port C GPIO — This GPIO pin can be individually programmed as an input or output pin.</p> <p>MOSI0 — Master out/slave in. In master mode, this pin serves as the data output. In slave mode, this pin serves as the data input.</p> <p>XB_IN5 — Crossbar module input 5.</p> <p>MISO0 — Master in/slave out. In master mode, this pin serves as the data input. In slave mode, this pin serves as the data output. The MISO0 line of a slave device is placed in the high-impedance state if the slave device is not selected.</p> <p>XB_OUT9 — Crossbar module output 9.</p> <p>After reset, the default state is GPIOC10.</p>
GPIOF0	36	XB_IN6/SCLK1	<p>Port F GPIO — This GPIO pin can be individually programmed as an input or output pin.</p> <p>XB_IN6 — Crossbar module input 6.</p> <p>SCLK1 — The SPI1 serial clock. In master mode, this pin serves as an output, clocking slaved listeners. In slave mode, this pin serves as the data clock input.</p> <p>After reset, the default state is GPIOF0.</p>
GPIOC11	37	CAN_TX/SCL0/ TXD1	<p>Port C GPIO — This GPIO pin can be individually programmed as an input or output pin.</p> <p>CANTX — CAN transmit data output.</p> <p>SCL0 — IIC0 serial clock.</p> <p>TXD1 — SCI1 transmit data output or transmit/receive in single wire operation.</p> <p>After reset, the default state is GPIOC11.</p>
GPIOC12	38	CAN_RX/SDA0/ RXD1	<p>Port C GPIO — This GPIO pin can be individually programmed as an input or output pin.</p> <p>CANRX — CAN receive data input.</p> <p>SDA0 — IIC0 serial data line.</p> <p>RXD1 — SCI1 receive data input.</p> <p>After reset, the default state is GPIOC12.</p>
GPIOF2	39	SCL0/XB_OUT 6/MISO1	<p>Port F GPIO — This GPIO pin can be individually programmed as an input or output pin.</p> <p>SCL0 — IIC0 serial clock.</p> <p>XB_OUT6 — Crossbar module output 6.</p>

			<p>MISO1 — Master in/slave out. In master mode, this pin serves as the data input. In slave mode, this pin serves as the data output. The MISO1 line of a slave device is placed in the high-impedance state if the slave device is not selected.</p> <p>After reset, the default state is GPIOF2.</p>
GPIOF3	40	SDA0/XB_OUT7/MOSI1	<p>Port F GPIO — This GPIO pin can be individually programmed as an input or output pin.</p> <p>SDA0 — IIC0 serial data line.</p> <p>XB_OUT7 — Crossbar module output 7.</p> <p>MOSI1 — Master out/slave in. In master mode, this pin serves as the data output. In slave mode, this pin serves as the data input.</p> <p>After reset, the default state is GPIOF3.</p>
GPIOF4	41	TXD1/XB_OUT8/PWM_0X/PWM_FAULT6	<p>Port F GPIO — This GPIO pin can be individually programmed as an input or output pin.</p> <p>TXD1 — The SCI1 transmit data output or transmit/receive in single wire operation.</p> <p>XB_OUT8 — Crossbar module output 8.</p> <p>PWM_0X — NanoEdge eFlexPWM sub-module 0 output X or input capture X.</p> <p>PWM_FAULT6 — NanoEdge eFlexPWM fault input 6.</p> <p>After reset, the default state is GPIOF4.</p>
GPIOF5	42	RXD1/XB_OUT9/PWM_1X/PWM_FAULT7	<p>Port F GPIO — This GPIO pin can be individually programmed as an input or output pin.</p> <p>RXD1 — The SCI1 receive data input.</p> <p>XB_OUT9 — Crossbar module output 9.</p> <p>PWM_1X — NanoEdge eFlexPWM sub-module 1 output X or input capture X.</p> <p>PWM_FAULT7 — NanoEdge eFlexPWM fault input 7.</p> <p>After reset, the default state is GPIOF5.</p>
VSS2	43	-	I/O Ground — Provides ground to on-chip digital module.
VDD2	44	-	I/O Power — Supplies 3.3 V power to on-chip digital module.
GPIOE0	45	PWM_0B	<p>Port E GPIO — This GPIO pin can be individually programmed as an input or output pin.</p> <p>PWM_0B — NanoEdge eFlexPWM sub-module 0 output B or input capture B.</p> <p>After reset, the default state is GPIOE0.</p>
GPIOE1	46	PWM_0A	<p>Port E GPIO — This GPIO pin can be individually programmed as an input or output pin.</p> <p>PWM_0A — NanoEdge eFlexPWM sub-module 0 output A or input capture A.</p>

			After reset, the default state is GPIOE1.
GPIOE2	47	PWM_1B	Port E GPIO — This GPIO pin can be individually programmed as an input or output pin. PWM_1B — NanoEdge eFlexPWM sub-module 1 output B or input capture B. After reset, the default state is GPIOE2.
GPIOE3	48	PWM_1A	Port E GPIO — This GPIO pin can be individually programmed as an input or output pin. PWM_1A — NanoEdge eFlexPWM sub-module 1 output A or input capture A. After reset, the default state is GPIOE3.
GPIOC13	49	TA3/XB_IN6/ EWM_OUT	Port C GPIO — This GPIO pin can be individually programmed as an input or output pin. TA3 — Quad timer module A channel 3 input/output. XB_IN6 — Crossbar module input 6. EWM_OUT — External watchdog monitor output. After reset, the default state is GPIOC13.
GPIOF1	50	CLKO1/XB_IN7/ CMPD_O	Port F GPIO — This GPIO pin can be individually programmed as an input or output pin. CLKO1 — This is a buffered clock output 1; the clock source is selected by clock out select (CLKOSEL) bits in the clock output select register (CLKOUT) of the SIM. XB_IN7 — Crossbar module input 7. CMPD_O — Analog comparator D output. After reset, the default state is GPIOF1.
GPIOE4	51	PWM_2B/XB_I N2	Port E GPIO — This GPIO pin can be individually programmed as an input or output pin. PWM_2B — NanoEdge eFlexPWM sub-module 2 output B or input capture B. XB_IN2 — Crossbar module input 2. After reset, the default state is GPIOE4.
GPIOE5	52	PWM_2A/XB_I N3	Port E GPIO — This GPIO pin can be individually programmed as an input or output pin. PWM_2A — NanoEdge eFlexPWM sub-module 2 output A or input capture A. XB_IN3 — Crossbar module input 3. After reset, the default state is GPIOE5.
GPIOE6	53	PWM_3B/XB_I N4	Port E GPIO — This GPIO pin can be individually programmed as an input or output pin. PWM_3B — NanoEdge eFlexPWM sub-module 3 output B or input capture B.

			<p>XB_IN4 — Crossbar module input 4.</p> <p>After reset, the default state is GPIOE6.</p>
GPIOE7	54	PWM_3A/XB_IN5	<p>Port E GPIO — This GPIO pin can be individually programmed as an input or output pin.</p> <p>PWM_3A — NanoEdge eFlexPWM sub-module 3 output A or input capture A.</p> <p>XB_IN5 — Crossbar module input 5.</p> <p>After reset, the default state is GPIOE7.</p>
GPIOC14	55	SDA0/XB_OUT4/PWM_FAULT4	<p>Port C GPIO — This GPIO pin can be individually programmed as an input or output pin.</p> <p>SDA0 — IIC0 serial data line.</p> <p>XB_OUT4 — Crossbar module output 4.</p> <p>PWM_FAULT4 — NanoEdge eFlexPWM fault input 4.</p> <p>After reset, the default state is GPIOC14.</p>
GPIOC15	56	SCL0/XB_OUT5/PWM_FAULT5	<p>Port C GPIO — This GPIO pin can be individually programmed as an input or output pin.</p> <p>SCL0 — IIC0 serial clock.</p> <p>XB_OUT5 — Crossbar module output 5.</p> <p>PWM_FAULT5 — NanoEdge eFlexPWM fault input 5.</p> <p>After reset, the default state is GPIOC15.</p>
VCAP2	57	-	<p>Connect a 2.2 <math>\mu</math>F or greater bypass capacitor between this pin and VSS to stabilize the core voltage regulator output required for proper device operation.</p>
GPIOF6	58	PWM_3X/XB_IN2	<p>Port F GPIO — This GPIO pin can be individually programmed as an input or output pin.</p> <p>PWM_3X — NanoEdge eFlexPWM sub-module 3 output X or input capture X.</p> <p>XB_IN2 — Crossbar module input 2.</p> <p>After reset, the default state is GPIOF6.</p>
GPIOF7	59	CMPC_O/ $\overline{SS1}$ /XB_IN3	<p>Port F GPIO — This GPIO pin can be individually programmed as an input or output pin.</p> <p>CMPC_O — Analog comparator C output.</p> <p><math>\overline{SS1}</math> — <math>\overline{SS1}</math> is used in slave mode to indicate to the SPI1 module that the current transfer is to be received.</p> <p>XB_IN3 — Crossbar module input 3.</p> <p>After reset, the default state is GPIOF7.</p>
VDD3	60	-	I/O Power — Supplies 3.3 V power to on-chip digital module.
VSS3	61	-	I/O Ground — Provides ground to on-chip digital module.
TDO	62	GPIOD1	<p>Test Data Output — This tri-stateable output pin provides a serial output data stream from the JTAG/EOnCE port. It is driven in the shift-IR and</p>

			<p>shift-DR controller states, and changes on the falling edge of TCK.</p> <p>Port D GPIO — This GPIO pin can be individually programmed as an input or output pin.</p> <p>After reset, the default state is TDO.</p>
TMS	63	GPIOD3	<p>Test Mode Select Input — This input pin is used to sequence the JTAG TAP controller's state machine. It is sampled on the rising edge of TCK and has an on-chip pull-up resistor.</p> <p>Port D GPIO — This GPIO pin can be individually programmed as an input or output pin.</p> <p>After reset, the default state is TMS.</p> <p>NOTE: Always tie the TMS pin to VDD through a 2.2 kΩ resistor if need to keep on-board debug capability. Otherwise, directly tie to VDD.</p>
TDI	64	GPIOD0	<p>Test Data Input — This input pin provides a serial input data stream to the JTAG/EOnCE port. It is sampled on the rising edge of TCK and has an on-chip pull-up resistor.</p> <p>Port D GPIO — This GPIO pin can be individually programmed as an input or output pin.</p> <p>After reset, the default state is TDI.</p>

## 4.5 Ordering Information

Table 1 lists the pertinent information needed to place an order. Consult a Freescale Semiconductor sales office to determine availability and to order this device.

**Table 10 MWCT1101CLH Ordering Information**

Device	Supply Voltage	Package Type	Pin Count	Ambient Temp.	Order Number
MWCT1101CLH	3.0 to 3.6V	LQFP	64	-40 to +85°C	MWCT1101CLH

## 4.6 Package Outline Drawing

To find a package drawing, go to [freescale.com](http://freescale.com) and perform a keyword search for the drawing's document number of 98ASS23234W.

## 5 Software Library

WCT1101 can not only run the core wireless charging function, but also allow user to add user application functions. Freescale provides two Wireless Charging Transmitter (WCT) software libraries (WCT1000 TX library and WCT1200 TX library) for different solutions design on WCT1101. In these libraries, low level drivers of HAL (Hardware Abstract Layer), callback functions for library access are open to user. For the software API and library details, see *WCT1000 TX Library User Guide.pdf* (WCT1000LIBUG).

## 5.1 Memory Map

WCT1101 has large on-chip Flash memory and RAM for user design. Besides for wireless charging transmitter library code, the user can develop private functions and link it to library through predefined APIs.

**Table 11. WCT1101 Memory Footprint**

Part	Memory	Total Size	Library Size	FreeMASTER Size	EEPROM Size	Free Size
WCT1101	Flash	64 Kbytes	19 Kbytes	1.5 Kbytes	1 Kbytes	42.5 Kbytes
	RAM	8 Kbytes	5.8 Kbytes	0.1 Kbytes	0 Kbytes	2.1 Kbytes

## 5.2 Software Library and API Description

For more and detailed information about WCT software library and API definition, see *WCT1000 TX Library User Guide.pdf* (WCT1000LIBUG).

# 6 Design Considerations

## 6.1 Electrical Design Considerations

Use the following list of considerations to assure correct operation of the device and system:

- The minimum bypass requirement is to place 0.01 - 0.1  $\mu$  F capacitors positioned as near as possible to the package supply pins. The recommended bypass configuration is to place one bypass capacitor on each of the VDD/VSS pairs, including VDDA/VSSA. Ceramic and tantalum capacitors tend to provide better tolerances.
- Bypass the VDD and VSS with approximately 10  $\mu$  F, plus the number of 0.1  $\mu$  F ceramic capacitors.
- Consider all device loads as well as parasitic capacitance due to PCB traces when calculating capacitance. This is especially critical in systems with higher capacitive loads that could create higher transient currents in the VDD and VSS circuits.
- Take special care to minimize noise levels on the VDDA, and VSSA pins.
- Using separate power planes for VDD and VDDA and separate ground planes for VSS and VSSA are recommended. Connect the separate analog and digital power and ground planes as near as possible to power supply outputs. If an analog circuit and digital circuit are powered by the same power supply, you should connect a small inductor or ferrite bead in serial with VDDA trace.
- If desired, connect an external RC circuit to the RESET pin. The resistor value should be in the range of 4.7 k $\Omega$  – 10 k $\Omega$ ; and the capacitor value should be in the range of 0.1  $\mu$  F – 4.7  $\mu$  F.



- Add a 2.2 kΩ external pull-up on the TMS pin of the JTAG port to keep device in a restate during normal operation if JTAG converter is not present.
- During reset and after reset but before I/O initialization, all I/O pins are at input mode with internal weak pull-up.
- To eliminate PCB trace impedance effect, each ADC input should have a no less than 33pF/10 Ω RC filter.
- To assure chip reliable operation, please reserve enough margin for chip electrical design. The figure 6 shows the relationship between electrical ratings and electrical operating characteristics for correct chip operation.

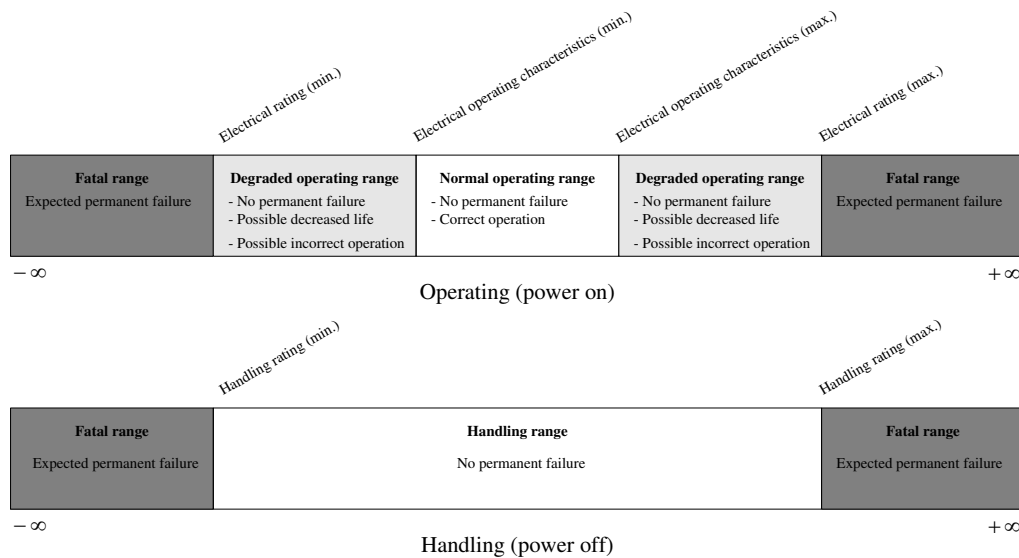

**Figure 6. Relationship between Ratings and Operating Characteristics**

## 6.2 PCB Layout Considerations

- Provide a low-impedance path from the board power supply to each VDD pin on the device and from the board ground to each VSS pin.
- Ensure that capacitor leads and associated printed circuit traces that connect to the chip VDD and VSS pins are as short as possible.
- PCB trace lengths should be minimal for high-frequency signals.
- Physically separate analog components from noisy digital components by ground planes. Do not place an analog trace in parallel with digital traces. Place an analog ground trace around an analog signal trace to isolate it from digital traces.
- The decoupling capacitors of 0.1 μ F must be placed on the VDD pins as close as possible, and place those ceramic capacitors on the same PCB layer with WCT1101 device. VIA is not recommend between the VDD pins and decoupling capacitors.

- The WCT1101 bottom EP pad should be soldered to the ground plane, which will make the system more stable, and VIA matrix method can be used to connect this pad to the ground plane.
- As the Wireless Charging system functions as a switching-mode power supply, the power components layout is very important for the whole system power transfer efficiency and EMI performance. The power routing loop should be small and short as can as possible, especially for the resonant network, the traces of this circuit should be short and wide, and the current loop should be optimized smaller for the MOSFETs, resonant capacitor and primary coil. Another important thing is that the control circuit and power circuit should be separated.

## 6.3 Thermal Design Considerations

WCT1101 power consumption is not so critical, so there is not additional part needed for power dissipation. However, the power inverter needs the additional PCB Cu copper to dissipate the heat, so good thermal package MOSFET is recommended to select, such as DFN package, and for the resonant capacitor, COG material, and 1206 or 1210 package are recommended to meet the thermal requirement. And the worst thermal case is on the inverter, so the user should make some special actions to dissipate the heat for good transmitter system thermal performance.

## 7 References and Links

### 7.1 References

- *WCT1000 All Reference Design System User Guide* (WCT1000SYSUG)
- *WCT1000 TX Library User Guide* (WCT1000LIBUG)
- *WCT Runtime Debug User Guide* (WCT1XXXRTDUG)
- *WCT1000 All Reference Design Calibration User Guide* (WCT1000CALUG)
- *WPC Low Power Wireless Transfer System Description Part 1: Interface Definition Version 1.1*

### 7.2 Useful Links

- [freescale.com](http://freescale.com)
- [freescale.com/wirelesscharging](http://freescale.com/wirelesscharging)
- [www.wirelesspowerconsortium.com](http://www.wirelesspowerconsortium.com)

**How to Reach Us:**

**Home Page:**

freescale.com

**Web Support:**

freescale.com/support

Information in this document is provided solely to enable system and software implementers to use Freescale products. There are no express or implied copyright licenses granted hereunder to design or fabricate any integrated circuits based on the information in this document.

Freescale reserves the right to make changes without further notice to any products herein. Freescale makes no warranty, representation, or guarantee regarding the suitability of its products for any particular purpose, nor does Freescale assume any liability arising out of the application or use of any product or circuit, and specifically disclaims any and all liability, including without limitation consequential or incidental damages. "Typical" parameters that may be provided in Freescale data sheets and/or specifications can and do vary in different applications, and actual performance may vary over time. All operating parameters, including "typicals," must be validated for each customer application by customer's technical experts. Freescale does not convey any license under its patent rights nor the rights of others. Freescale sells products pursuant to standard terms and conditions of sale, which can be found at the following address: [freescale.com/SalesTermsandConditions](http://freescale.com/SalesTermsandConditions).

Freescale and the Freescale logo are trademarks of Freescale Semiconductor, Inc., Reg. U.S. Pat. & Tm. Off. All other product or service names are the property of their respective owners.

©2014 Freescale Semiconductor, Inc.