

Description

Designed for digital, ECL, and analog application, the DFC6 Series will provide up to 6 watts in an industry standard package. Ultra-wide input voltage range allows operation from battery power as well as system power. The output is electrically isolated, thereby allowing the output to be configured as a positive or negative output voltage. Fully-isolated and filtered outputs permit usage in sensitive and low noise circuits.

The 100 kHz operating frequency of the DFC6 Series allows an increased power density while including adequate heatsinking and input/output filtering. This eliminates the need for external components in most applications.

Features

- RoHS lead solder exemption compliant
- Ultra-wide 3.5 to 16 volt input range
- Input filtered
- 6 watts of output power
- Efficiencies to 77%
- 700 V isolation
- Low input-to-output capacitance
- Ultra-wide input range (4:1)



Selection Chart				
Model	Input Range VDC (4)		Output VDC	Output mA
	Min	Max		
DFC6U5S5	3.5	16	5	1200
DFC6U5S5.2	3.5	16	5.2	1200
DFC6U5S12	3.5	16	12	500
DFC6U5S15	3.5	16	15	400

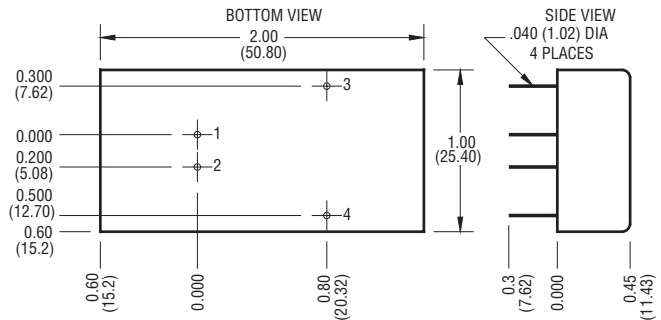

Mechanical tolerances unless otherwise noted:

X.XX dimensions: ±0.020 inches

X.XXX dimensions: ±0.005 inches

General Specifications (1)			
All Models			Units
Isolation			
Isolation Voltage Input to Output 10 A Leakage	MIN	700	VDC
Input to Output Capacitance	TYP	300	pF
Environmental			
Case Operating Range, Tc No Derating	MIN	-40	°C
	MAX	85	
Case Functional Range (2)	MIN	-50	°C
	MAX	100	
Storage Range	MIN	-55	°C
	MAX	105	
Thermal Impedance (3)	TYP	19	°C/Watt
General			
MTBF (Calculated)	TYP	800,000	HRS
Unit Weight	TYP	0.9 / 25.6	oz / gm
Chassis Mounting Kit	CM2B1		

Pin	Function
1	+INPUT
2	-INPUT
3	+OUT
4	-OUT

NOTES

- (1) All parameters measured at Tc=25 °C, nominal input voltage and full rated load unless otherwise noted.
- (2) The functional temperature range is intended to give an additional data point for use in evaluating this power supply. At the low functional temperature the power supply will function with no side effects. However, sustained operation at the high functional temperature will reduce expected operational life. The data sheet specifications are not guaranteed beyond the case operating range.
- (3) The case thermal impedance is specified as the case temperature rise over ambient per package dissipated.
- (4) Reduced output power available with 3.5 V input. Full power is available above 4.6 V input. See input voltage derating curve for more information.

Input Parameters (1)						
Model		DFC6U5S5	DFC6U5S5.2	DFC6U5S12	DFC6U5S15	Units
Voltage Range (2)	MIN	3.5				VDC
	MAX	16				
Input Current	Full Load	1680	1750	1680	1670	mA
	No Load	10	10	10	20	
Switching Frequency	TYP	100				kHz
Maximum Input Overvoltage, 100ms Maximum	MAX	20				VDC
Turn-on Time, 1% Output Error	TYP	10				ms

Output Parameters (1)						
Model		DFC6U5S5	DFC6U5S5.2	DFC6U5S12	DFC6U5S15	Units
Output Voltage		5	5.2	12	15	VDC
Output Voltage Accuracy	MIN	4.95	5.15	11.900	14.900	VDC
	TYP	5.00	5.20	12.000	15.000	
	MAX	5.05	5.25	12.100	15.100	
Rated Load Range (5)	MIN	0	0	0	0	mA
	MAX	1200	1200	500	400	
Load Regulation 25% Max Load - Max Load	TYP	0.3	0.3	0.1	0.1	%
	MAX	0.7	0.7	0.5	0.5	
Line Regulation Vin = Min-Max VDC	TYP	0.1				%
	MAX	0.2				
Short Term Stability (4)	TYP	< 0.05				%/24Hrs
Long Term Stability	TYP	< 0.1				%/kHrs
Noise, Peak - Peak (3)	TYP	75	75	50	40	mV _{pp}
RMS Noise	TYP	20	20	10	8	mV _{rms}
Temperature Coefficient	TYP	50				ppm/°C
	MAX	150				
Short Circuit Protection to Common for all Outputs		Short Term Current Limit				

NOTES

- (1) All parameters measured at Tc=25 °C, nominal input voltage and full rated load unless otherwise noted.
- (2) Reduced output power available at 3.5 V input. Full output power is available above 4.6 V input. See input voltage derating curve for more information.
- (3) Noise measurement bandwidth is 0-20 MHz for peak-to-peak measurements, 10 kHz to 1 MHz for RMS measurements. Output noise is measured with a 1µF/35V Tantalum capacitor located 1" away from the converter to simulate PCB standard decoupling.
- (4) Short term stability is specified after a 30-minute warmup at full load, constant line, and recording the drift over a 24-hour period.
- (5) No minimum load required for operation. Dynamic regulation may degrade when run with less than 5% load.

DFC6 Series Application Notes:

External Capacitance Requirements

No external capacitance is required for operation of the DFC6 Series. To meet the reflected ripple requirements of the converter, an input impedance of less than 0.15 Ohms from DC to 200 kHz is required. If a capacitive input source is farther than 1" from the converter, an additional

capacitor may be required at the input pins for proper operation. External output capacitance is not required for operation, however it is recommended that 1 µF to 10 µF of tantalum and 0.001 to 0.1 µF ceramic capacitance be selected for reduced system noise. Additional output capacitance may be added for increased filtering, but should not exceed 400 µF.

Output Power

The available output power of the DFC6 Series is reduced when operating below 4.6 volts. See Input Voltage Derating curve. Below 4.6 volts the output power is linearly derated from 100% at 4.6 volts to 50% at 3.5 volts.

Negative Outputs

A negative output voltage may be obtained by connecting the +OUT to circuit ground and connecting -OUT as the negative output.

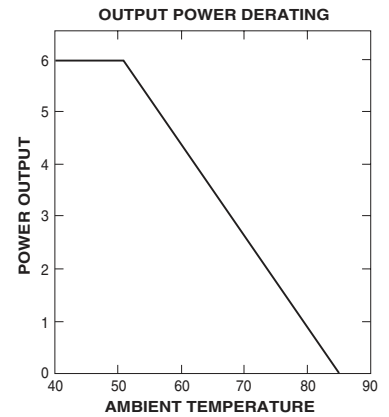
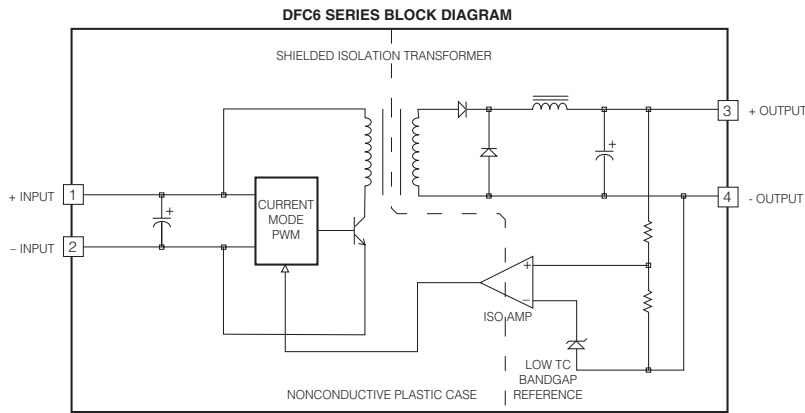

Typical Performance: (Tc=25°C, Vin=Nom VDC, Rated Load)

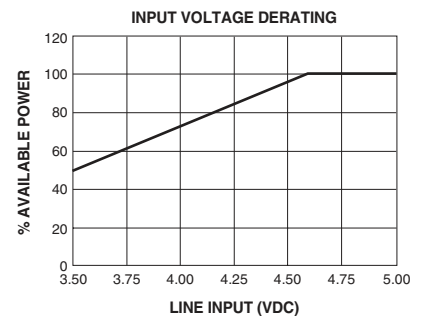
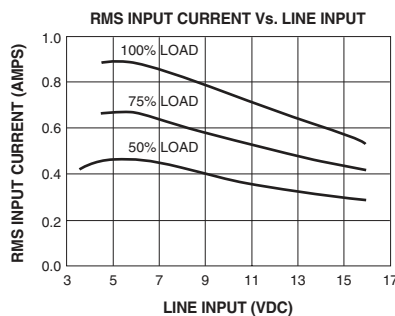
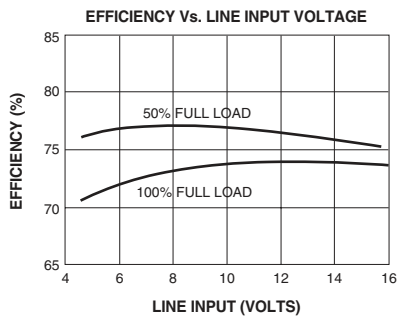
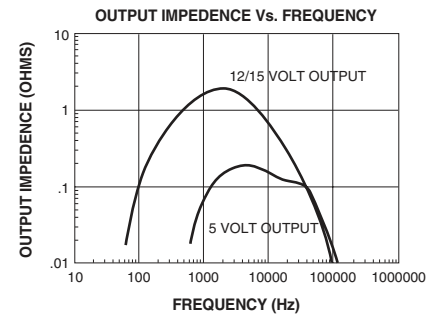
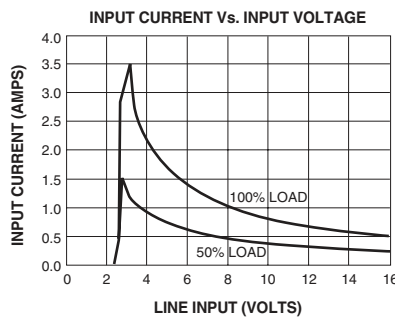
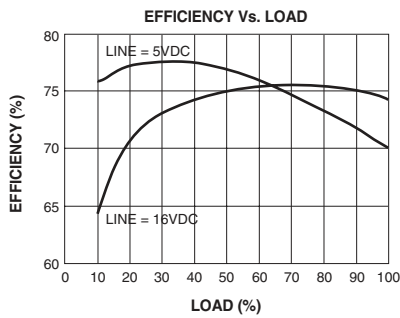

NUCLEAR AND MEDICAL APPLICATIONS - Power-One products are not designed, intended for use in, or authorized for use as critical components in life support systems, equipment used in hazardous environments, or nuclear control systems without the express written consent of the respective divisional president of Power-One, Inc.

TECHNICAL REVISIONS - The appearance of products, including safety agency certifications pictured on labels, may change depending on the date manufactured. Specifications are subject to change without notice.