

PART NUMBER	REVISION	DESCRIPTION	FEED TYPE
2150053-2	G	FINE CRIMP HEIGHT ADJUST	PNEUMATIC
7-2150053-2	G	PNEUMATIC AND CRIMP TOOLING KIT	PNEUMATIC
7-2150053-7	A	CRIMP TOOLING KIT	-

ATLANTIC VERSION TERMINATOR INTERFACE ADAPTER

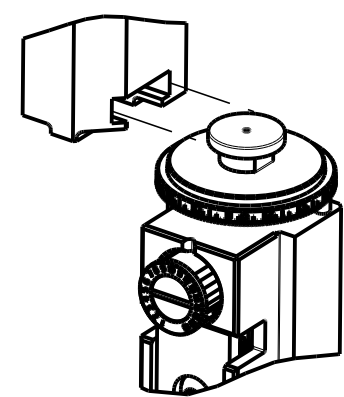

APPLICATOR DATA		
CRIMP	SIZE	TYPE
WIRE	3.30 mm [.130]	F
INSUL	3.94 mm [.155]	OV
APPLICATOR INSTRUCTIONS 408-35043		

TERMINAL DATA: TE TERMINAL TE CRIMP SPECIFICATION			
TERMINAL NAME: RING TONGUE			
WIRE STRIP LENGTH		INSULATION DIAMETER RANGE	
6.00-6.00 mm [.236-.236 IN]		∅2.10-3.10 mm [.083-.122 IN]	
TERMINAL APPLICATION SPECIFICATION	114-2084		
TERMINALS APPLIED			
TE TERMINAL	TE TERMINAL	TE TERMINAL	TE TERMINAL
346103-1	346103-2	346103-3	346103-4

WIRE SIZE	CRIMP HEIGHT mm [INCH]	CRIMP HEIGHT REFERENCE SETTING
2.50mm2	2.40 +/- 0.05 [.094 +/- .002]	7.4
2.00mm2	2.28 +/- 0.05 [.090 +/- .002]	9.0
1.50mm2	2.16 +/- 0.05 [.085 +/- .002]	9.8

- RECOMMENDED SPARE PARTS
- REFER TO SUPPLIED INSTRUCTION SHEET FOR CLEANING, LUBRICATION AND STORAGE OF APPLICATOR.
- APPLY PART NUMBER 2-23419-6 LOCTITE TO THREADS OF ITEM 242.
- CRIMP HEIGHT REFERENCE SETTING WAS THE SETTING USED WHEN THE APPLICATOR WAS QUALIFIED AT THE FACTORY. ADJUSTMENT MAY BE NECESSARY WHEN RUNNING APPLICATOR IN THE FIELD.
- TERMINAL PITCH NOT COMPATIBLE WITH MECHANICAL FEED.
- 6. UNLESS SPECIFIED OTHERWISE TORQUE VALUES SHALL BE USED PER DOCUMENT, 101-35000.
- TERMINAL LUBRICANT IS RECOMMENDED.

**\*WARNING**  
ON INSTALLATION, SET WIRE DISC TO CRIMP HEIGHT REFERENCE SETTING FOR LARGEST WIRE SIZE. CRIMP HEIGHT REFERENCE SETTINGS GREATER THAN THE VALUE SHOWN MAY CAUSE DAMAGE TO THE CRIMP TOOLING, REFER TO THE INSTRUCTION SHEET FOR PROPER SETUP AND ADJUSTMENTS.

ATLANTIC VERSION  
Shown on sheets 1 of 4 & 2 of 4  
(Pacific version shown on sheets 3 of 4 & 4 of 4)

LOC	DIST	REV	LTN	DESCRIPTION	DATE	OWN	APVD
A	66						
		D2		ECR-18-015886	08OCT2018	KH	CT
		E		ECR-19-011869	27JUL2019	TB	TE
		F		ECR-19-018138	20NOV2019	FZ	RK
		G		ECR-21-005746	26MAY2021	FZ	RK

-	1	1	2119641-1	FEED CAM, AIR FEED	248
-	1	1	2119082-9	CAM, SNAIL, INSULATION ADJUSTMENT	244
-	1	1	2079764-1	WASHER, WAVE SPRING, CREST-TO-CREST	243
-	1	1	2119083-1	RETAINER, INSULATION DIAL	242
-	1	1	2844940-4	AIR FEED MODULE	238
-	1	1	1-18028-0	WASHER, FLAT, REG M8	192
-	REF	REF	994970-2	COUNTER, MAGNETIC	164
-	1	1	2119955-2	ASSY, LUBRICATOR, END FEED	84
-	1	1	455888-5	SPACER, CRIMPER	82
-	1	1	1803607-4	DOCUMENTATION PACKAGE	71
-	2	2	2-18032-2	SCR, SET, FLT PNT, M3 X 10.0	70
-	1	1	2119740-1	TAG, IDENTIFICATION	67
-	2	2	2168078-1	SCREW, DRIVE, RH, RoHS, 2 x .188	66
-	1	1	2168083-2	SCR, SKT HD CAP, RoHS, M4 X 8.0	60
-	1	1	5-18022-5	SCR, HEX HD CAP, M4 X 6.0	59
-	4	4	2168400-4	SHCS, LOW HEAD, RoHS, M4 X 8	57
-	2	2	2168083-8	SCR, SKT HD CAP, RoHS, M4 X 16	56
-	2	2	5018030-1	NUT, HEX, REG, RoHS, M3	54
-	2	2	986965-8	NUT, LOCK, HEX, TORQUE (M4)	53
-	1	1	2063961-9	FEED FINGER	51
-	1	1	18023-9	SCR, SKT HD CAP M4 X 6.0	49
-	1	1	2119655-5	APPLICATOR BASIC ASSEMBLY, EF	46
-	1	1	1803517-1	RAM ASSEMBLY, EF ATLANTIC	44
-	1	1	1803602-1	SCR, BHSC, RoHS (M8 X 25)	41
-	8	8	1-18028-2	WASHER, FLAT, REG M4	33
-	2	2	2168083-9	SCR, SKT HD CAP, RoHS, M4 X 20	31
-	2	2	2168083-2	SCR, SKT HD CAP, RoHS, M4 X 8.0	29
-	1	1	240639-1	STRIPPER (MACHINING)	27
-	2	2	1-2168083-5	SCR, SKT HD CAP, RoHS, M4 X 30	25
-	1	1	1752371-5	PLATE, STRIP GUIDE	24
-	2	2	2-22281-3	SPRING, COMPRESSION	22
-	1	1	1803292-1	DRAG	20
-	1	1	1901696-4	STRIP GUIDE, REAR	19
-	1	1	1901695-4	STRIP GUIDE, FRONT	18
-	4	4	1-2079383-1	SCR, BHSC, RoHS (M6 X 12)	17
-	1	1	240641-9	SPACER	16
-	1	1	240644-1	PLATE, REAR SHEAR	11
-	-	-	-	-	10
-	1	1	690482-5	PLATE, FRONT SHEAR	9
-	1	2	1333221-4	ANVIL, EF .130	8
-	1	1	2217206-8	BLADE, SLUG	7
-	1	1	6-240641-0	SPACER	5
-	1	1	238011-2	BLOCK, CRIMPER SPACER	4
-	1	2	1-2119785-6	CRIMPER, INSULATION OVERLAP PREMIUM	3
-	1	1	1-455888-3	SPACER, CRIMPER	2
-	1	2	3-456410-0	CRIMPER, WIRE PREMIUM	1
-	77	72	2	PART NO	ITEM NO

DIMENSIONS:		TOLERANCES UNLESS OTHERWISE SPECIFIED:		OWN: C. MOYER 30NOV2011		TE Connectivity	
mm		0 PLC ±		CHK: G. BAILEY 30NOV2011		Harrisburg, PA 17105-3608	
		1 PLC ±		APVD: G. BAILEY 30NOV2011		NAME: Ocean End Feed Applicator	
		2 PLC ±		PRODUCT SPEC		SIZE: CAGE CODE DRAWING NO	
		3 PLC ±		APPLICATION SPEC		RESTRICTED TO	
		4 PLC ±		WEIGHT		A1 00779 C=2150053	
		ANGLES		CUSTOMER ACCESSIBLE PRODUCTION DRAWING		SCALE: 1:1 SHEET 1 OF 4 REV G	

LOC	DIST	REV	DATE	BY	APPD	
A	66					
REVISIONS			DESCRIPTION	DATE	DWN	APPD
			SEE SHEET 1			

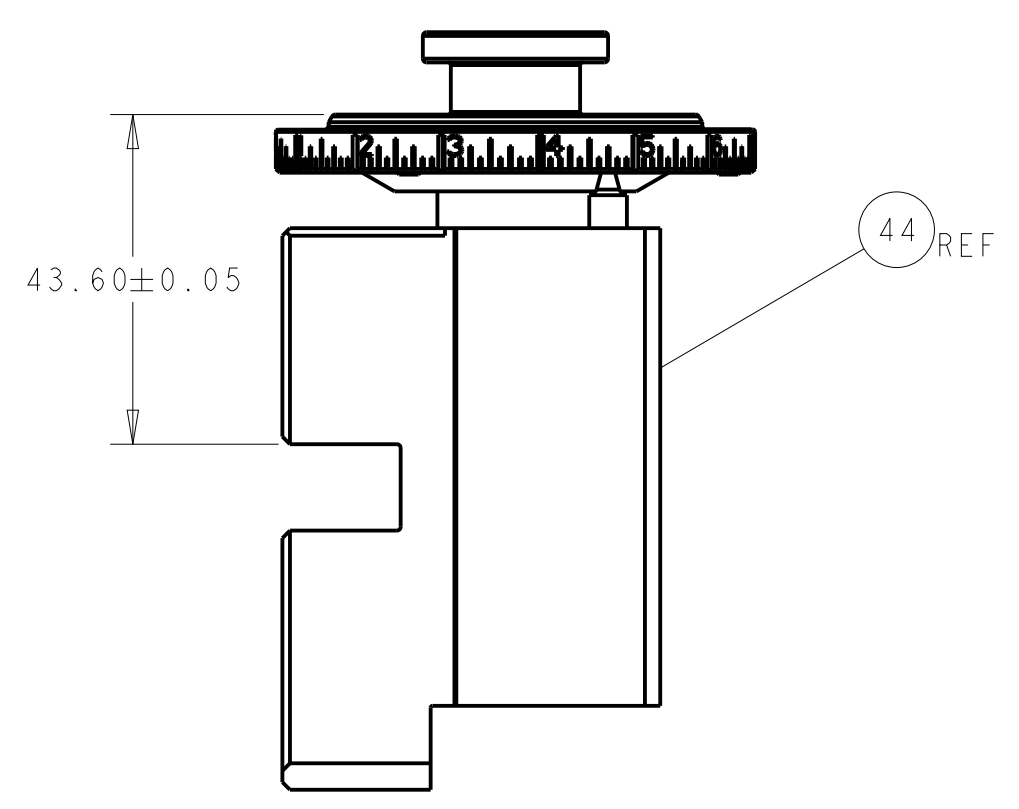

RAM SET-UP

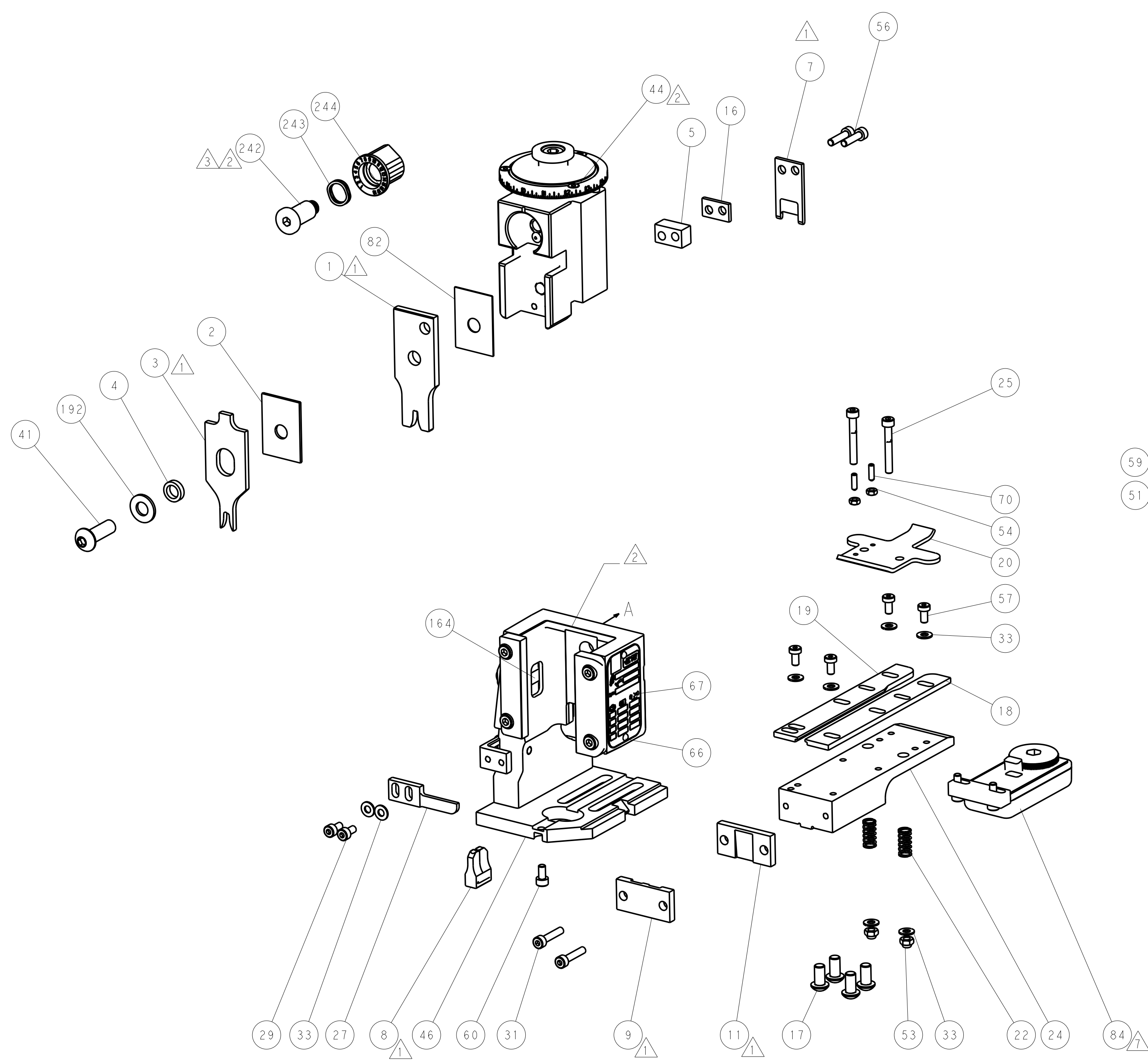

FEED TYPE

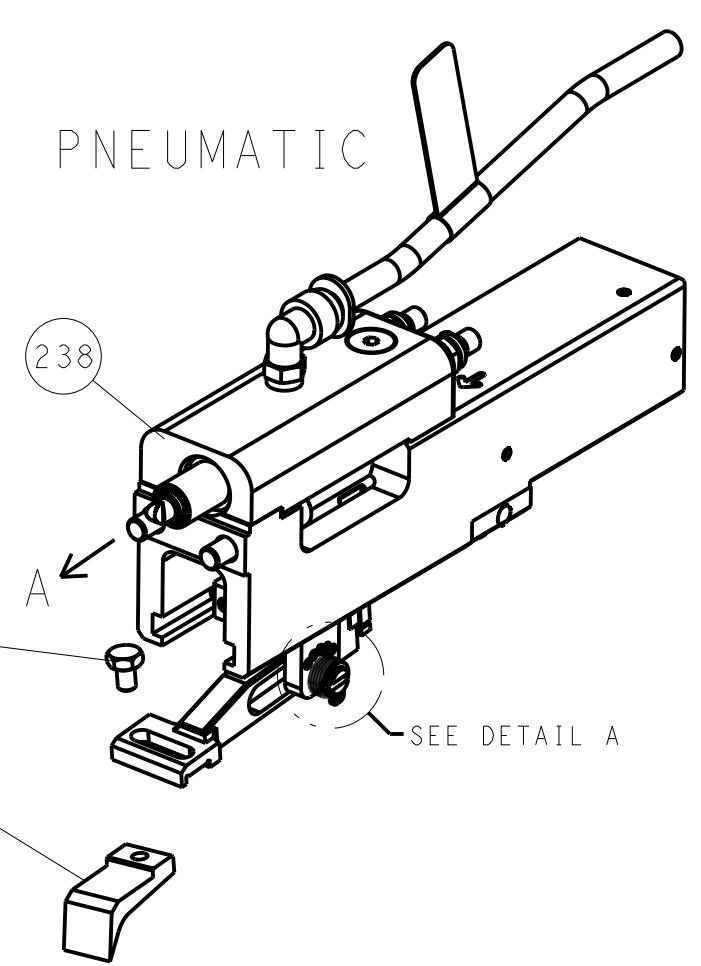

CAM POSITION

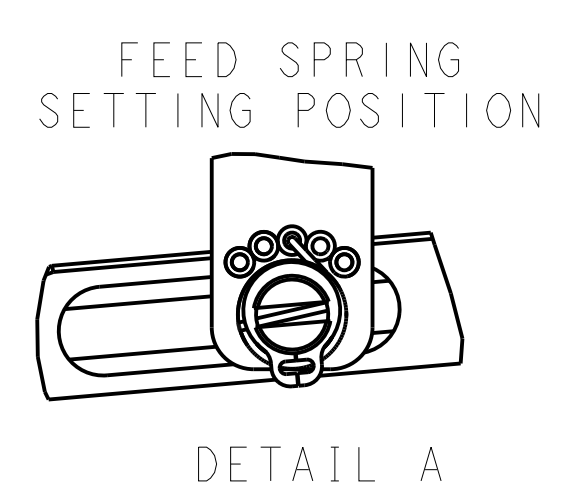
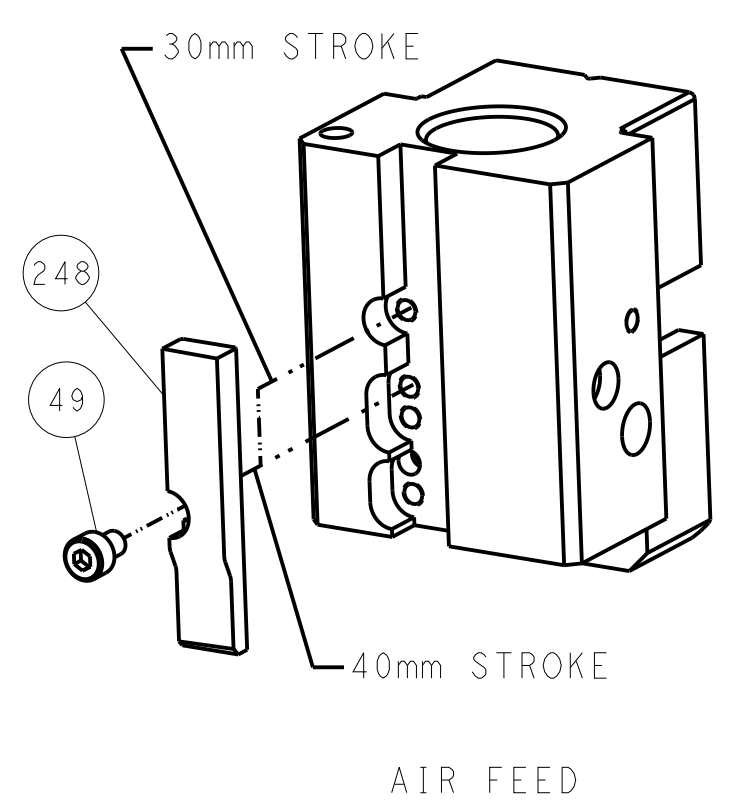

ATLANTIC VERSION  
 Shown on sheets 1 of 4 & 2 of 4  
 (Pacific version shown on sheets 3 of 4 & 4 of 4)

DIMENSIONS: mm 		TOLERANCES UNLESS OTHERWISE SPECIFIED: 0 PLC ± 1 PLC ± 2 PLC ± 3 PLC ± 4 PLC ± ANGLES ±		DWN C. MOYER 30NOV2011 CHK G. BAILEY 30NOV2011 APVD G. BAILEY 30NOV2011 PRODUCT SPEC APPLICATION SPEC WEIGHT CUSTOMER ACCESSIBLE PRODUCTION DRAWING		NAME Ocean End Feed Applicator SIZE CAGE CODE DRAWING NO A1 00779 C=2150053 SCALE 1:1 SHEET 2 OF 4 REV G		RESTRICTED TO	
MATERIAL FINISH		FINISH		SCALE 1:1		SHEET 2 OF 4		REV G	

THIS DRAWING IS UNPUBLISHED.	RELEASED FOR PUBLICATION		
COPYRIGHT © BY TYCO ELECTRONICS CORPORATION. ALL RIGHTS RESERVED.			
PART NUMBER	REVISION	DESCRIPTION	FEED TYPE
2-2150053-2	G	FINE CRIMP HEIGHT ADJUST	PNEUMATIC
7-2150053-7	A	CRIMP TOOLING KIT	-

PACIFIC VERSION TERMINATOR  
INTERFACE ADAPTER

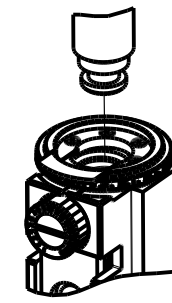

APPLICATOR DATA		
CRIMP	SIZE	TYPE
WIRE	3.30 mm [.130]	F
INSUL	3.94 mm [.155]	OV
APPLICATOR INSTRUCTIONS 408-35043		

TERMINAL DATA: TE TERMINAL		TE CRIMP SPECIFICATION	
TERMINAL NAME: RING TONGUE			
WIRE STRIP LENGTH 6.00-6.00 mm [.236-.236 IN]		INSULATION DIAMETER RANGE Ø2.10-3.10 mm [.083-.122 IN]	
TERMINAL APPLICATION SPECIFICATION	114-2084	-	-
TERMINALS APPLIED			
TE TERMINAL	TE TERMINAL	TE TERMINAL	TE TERMINAL
346103-1	346103-2	346103-3	346103-4

WIRE SIZE	CRIMP HEIGHT mm [INCH]	CRIMP HEIGHT REFERENCE SETTING
2.50mm2	2.40 +/- 0.05 [.094 +/- .002]	7.4
2.00mm2	2.28 +/- 0.05 [.090 +/- .002]	9.0
1.50mm2	2.16 +/- 0.05 [.085 +/- .002]	9.8

- RECOMMENDED SPARE PARTS
- REFER TO SUPPLIED INSTRUCTION SHEET FOR CLEANING, LUBRICATION AND STORAGE OF APPLICATOR.
- APPLY PART NUMBER 2-23419-6 LOCTITE TO THREADS OF ITEM 242.
- CRIMP HEIGHT REFERENCE SETTING WAS THE SETTING USED WHEN THE APPLICATOR WAS QUALIFIED AT THE FACTORY. ADJUSTMENT MAY BE NECESSARY WHEN RUNNING APPLICATOR IN THE FIELD.
- TERMINAL PITCH NOT COMPATIBLE WITH MECHANICAL FEED.
- UNLESS SPECIFIED OTHERWISE TORQUE VALUES SHALL BE USED PER DOCUMENT, 101-35000.
- TERMINAL LUBRICANT IS RECOMMENDED.

**\*WARNING**  
ON INSTALLATION, SET WIRE DISC TO CRIMP HEIGHT REFERENCE SETTING FOR LARGEST WIRE SIZE. CRIMP HEIGHT REFERENCE SETTINGS GREATER THAN THE VALUE SHOWN MAY CAUSE DAMAGE TO THE CRIMP TOOLING, REFER TO THE INSTRUCTION SHEET FOR PROPER SETUP AND ADJUSTMENTS.

PACIFIC VERSION  
Shown on sheets 3 of 4 & 4 of 4  
(Atlantic version shown on sheets 1 of 4 & 2 of 4)

LOC	DIST	REV	LTN	DESCRIPTION	DATE	OWN	APVD
A	66	-	-	SEE SHEET 1	-	-	-

-	1	2119082-9	CAM, SNAIL, INSULATION ADJUSTMENT	244
-	1	2079764-1	WASHER, WAVE SPRING, CREST-TO-CREST	243
-	1	2119083-1	RETAINER, INSULATION DIAL	242
-	1	2844940-4	AIR FEED MODULE	238
-	1	1-18028-0	WASHER, FLAT, REG M8	192
-	4	2079383-9	SCR, BHSC, RoHS (M6 X 20)	186
-	REF	994970-2	COUNTER, MAGNETIC	164
-	1	2119641-2	FEED CAM, AIR FEED	152
-	1	2168083-8	SCR, SKT HD CAP, RoHS, M4 X 16	144
-	1	2119655-6	APPLICATOR BASIC ASSEMBLY, EF	141
-	1	1803518-1	RAM ASSEMBLY, EF PACIFIC	140
-	1	2119955-2	ASSY, LUBRICATOR, END FEED	84
-	1	455888-5	SPACER, CRIMPER	82
-	1	1803607-4	DOCUMENTATION PACKAGE	71
-	2	2-18032-2	SCR, SET, FLT PNT, M3 X 10.0	70
-	1	2119740-1	TAG, IDENTIFICATION	67
-	2	2168078-1	SCREW, DRIVE, RH, RoHS, 2 x .188	66
-	1	5-18022-5	SCR, HEX HD CAP, M4 X 6.0	59
-	4	2168400-4	SHCS, LOW HEAD, RoHS, M4 X 8	57
-	2	2168083-8	SCR, SKT HD CAP, RoHS, M4 X 16	56
-	2	5018030-1	NUT, HEX, REG, RoHS, M3	54
-	2	986965-8	NUT, LOCK, HEX, TORQUE (M4)	53
-	1	2063961-9	FEED FINGER	51
-	1	18023-9	SCR, SKT HD CAP M4 X 6.0	49
-	1	1803602-1	SCR, BHSC, RoHS (M8 X 25)	41
-	8	1-18028-2	WASHER, FLAT, REG M4	33
-	2	2168083-9	SCR, SKT HD CAP, RoHS, M4 X 20	31
-	2	2168083-2	SCR, SKT HD CAP, RoHS, M4 X 8.0	29
-	1	240639-1	STRIPPER (MACHINING)	27
-	2	1-2168083-5	SCR, SKT HD CAP, RoHS, M4 X 30	25
-	1	1752371-5	PLATE, STRIP GUIDE	24
-	2	2-22281-3	SPRING, COMPRESSION	22
-	1	1803292-1	DRAG	20
-	1	1901696-4	STRIP GUIDE, REAR	19
-	1	1901695-4	STRIP GUIDE, FRONT	18
-	1	240641-9	SPACER	16
-	1	240644-1	PLATE, REAR SHEAR	11
-	-	-	-	10
-	1	690482-5	PLATE, FRONT SHEAR	9
1	1	1333221-4	ANVIL, EF .130	8
-	1	2217206-8	BLADE, SLUG	7
-	1	6-240641-0	SPACER	5
-	1	238011-2	BLOCK, CRIMPER SPACER	4
1	1	1-2119785-6	CRIMPER, INSULATION OVERLAP PREMIUM	3
-	1	1-455888-3	SPACER, CRIMPER	2
1	1	3-456410-0	CRIMPER, WIRE PREMIUM	1
-	77-22	PART NO	DESCRIPTION	ITEM NO

DIMENSIONS: mm		TOLERANCES UNLESS OTHERWISE SPECIFIED:		DWN C. MOYER 30NOV2011		CHK G. BAILEY 30NOV2011		APVD G. BAILEY 30NOV2011		NAME	
0 PLC ±		1 PLC ±		2 PLC ±		3 PLC ±		4 PLC ±		PRODUCT SPEC	
ANGLES		FINISH		WEIGHT		SCALE		SHEET		REV	
MATERIAL		FINISH		WEIGHT		SCALE		SHEET		REV	
CUSTOMER ACCESSIBLE PRODUCTION DRAWING		SCALE 1:1		SHEET 3 OF 4		REV G		00779		©=2150053	

LOC	DIST	REV	DATE	BY	APPV	
A	66					
REVISIONS			DESCRIPTION	DATE	DWN	APPV
			SEE SHEET 1			

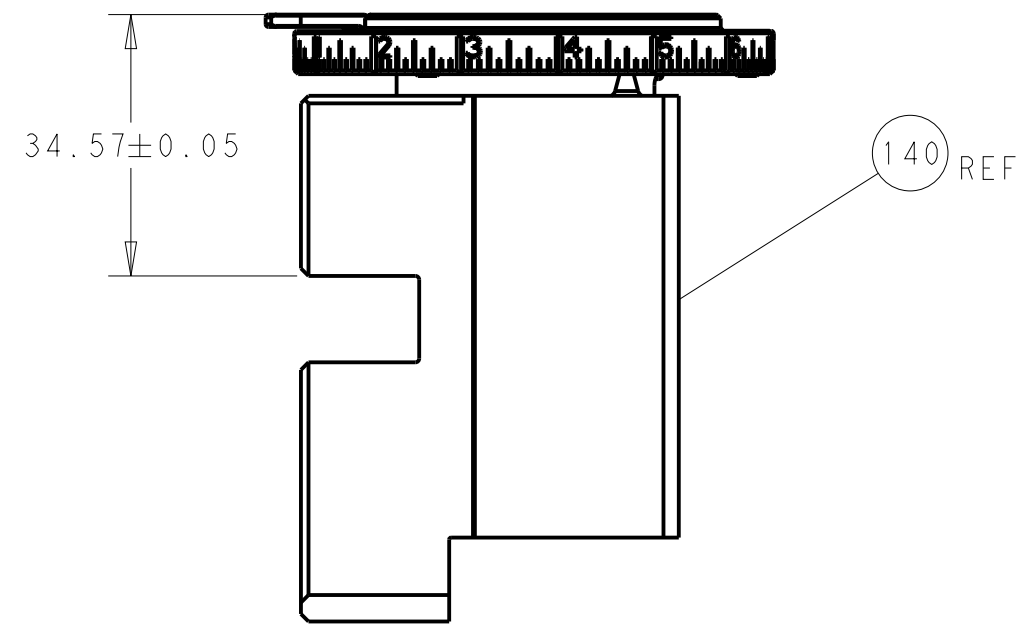

RAM SET-UP

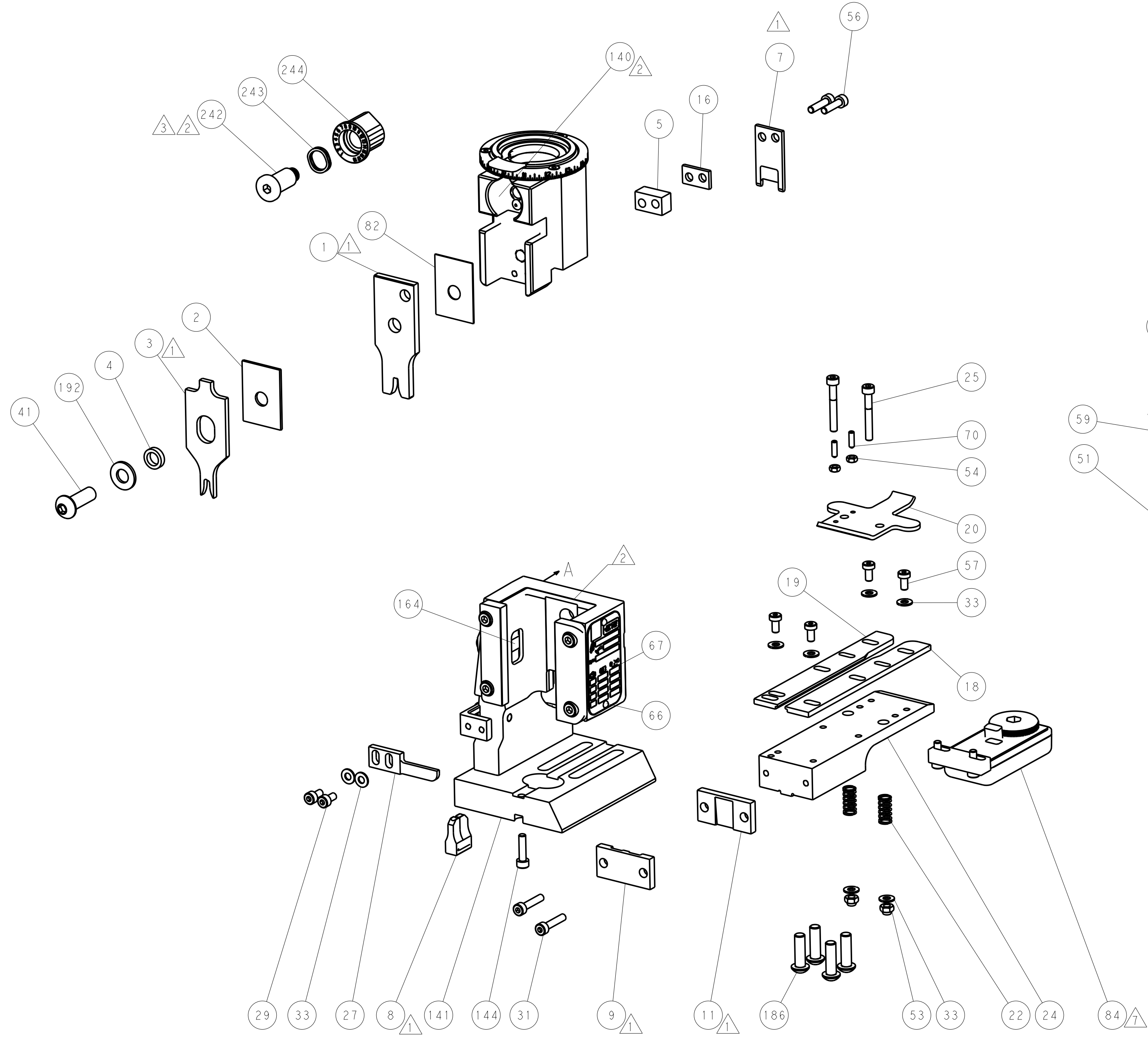

FEED TYPE

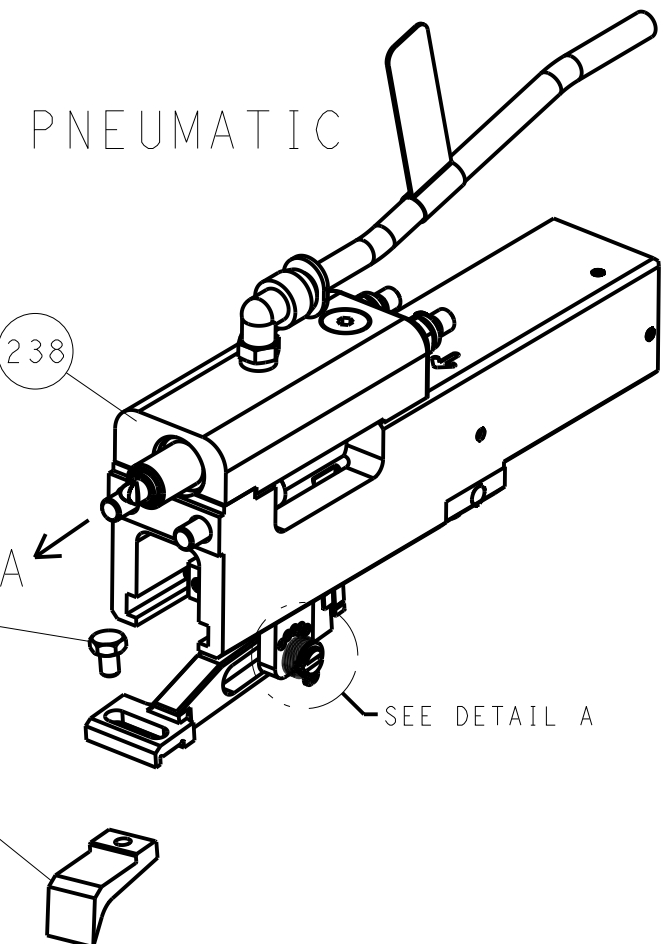

FEED SPRING SETTING POSITION

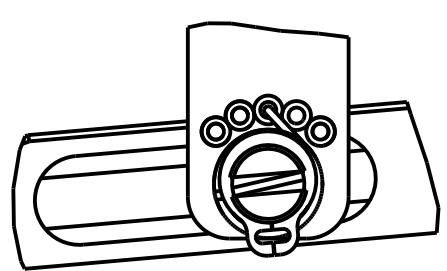

DETAIL A

CAM POSITION

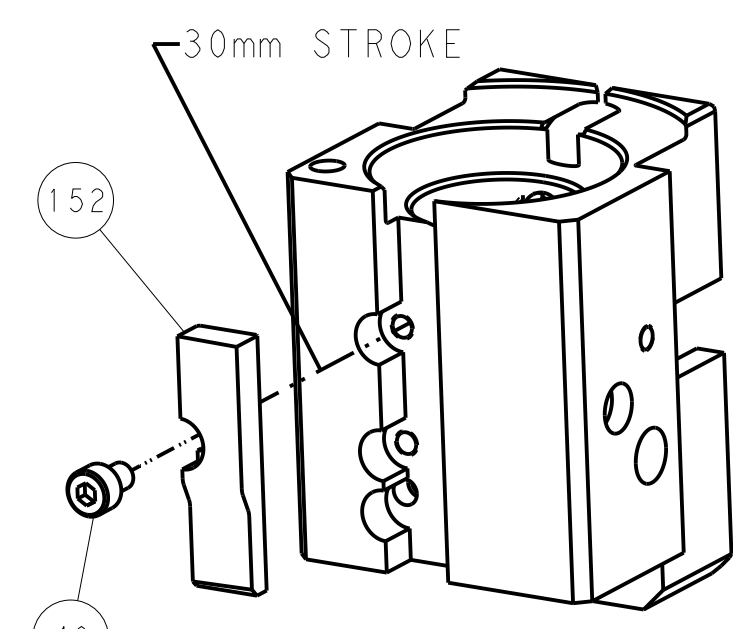

AIR FEED

PACIFIC VERSION  
 Shown on sheets 3 of 4 & 4 of 4  
 (Atlantic version shown on sheets 1 of 4 & 2 of 4)

DIMENSIONS:		TOLERANCES UNLESS OTHERWISE SPECIFIED:		DWN C. MOYER 30NOV2011		STE TE Connectivity	
mm	0 PLC ±	1 PLC ±	2 PLC ±	3 PLC ±	4 PLC ±	Harrisburg, PA 17105-3608	
	ANGLES ±			CHK G. BAILEY 30NOV2011		NAME Ocean End Feed Applicator	
MATERIAL	FINISH			APPV G. BAILEY 30NOV2011		SIZE CAGE CODE DRAWING NO RESTRICTED TO	
				PRODUCT SPEC		A 00779 C=2150053	
				APPLICATION SPEC		SCALE 1:1 SHEET 4 OF 4 REV G	
				WEIGHT		CUSTOMER ACCESSIBLE PRODUCTION DRAWING	