

# T4400 Load Sharer

- Automatic load sharing with voltage based speed control
- Adaptable to most speed controllers
- 2-wire communication with other T4400 Load Sharers
- Built-in frequency control
- Load / unload facility with ramp function
- Reverse power and unloaded trip
- Visual indication of voltage, generator C/B state and unload signal
- Cost effective and highly reliable compact design
- 50 hours burn-in before final test
- Operating temperature range: -20°C to +70°C
- Flame retardant enclosure
- DIN rail or screw mounting

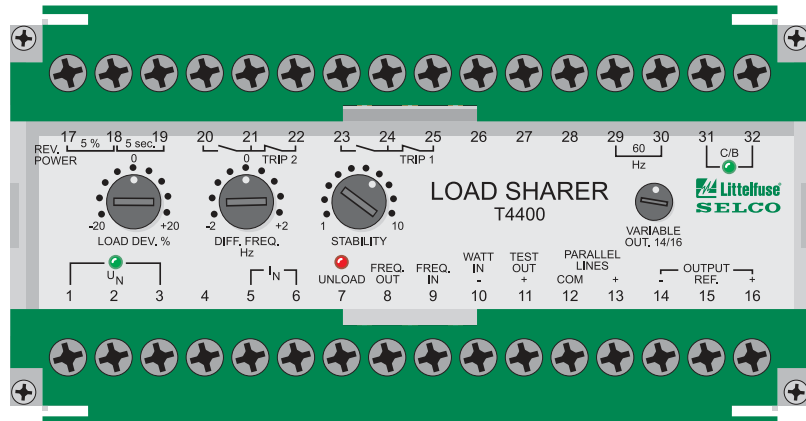

## Application

The T4400 Load Sharer provides automatic load sharing and frequency control for parallel running generators. The load sharing is proportional, meaning that the generators will be loaded equally compared to their individual capacity.

The T4400 works in connection with most electronic speed controllers.

The load on each generator is compared with the load on the other generators and corrected until balance is obtained.

Load sharing is necessary after synchronization in order to re-establish load balance and to obtain long term stability of load and system frequency.

When applied with the B9300 Power Reference Unit, one or several generators can be operated in parallel with the grid (utility).

Together with the T4000 Auto Synchronizer, the T4400 provides the optimal solution for generator control, both in land and marine-based applications. The T4900 VAR-Load Sharer can be used as a supplement. The combination of the T4400 and the T4900 will provide complete load sharing of both active load and reactive load.

## Function

The input to the T4400 is the voltage and current, from which the active load and frequency are determined.

The T4400 calculates  $I \times \cos \phi$ , representing the active load. The load on each generator is compared with the load on the other generators and calculated into a control signal that is connected to the electronic speed controller for regulating the load with optimal speed and stability.

The T4400 includes a built-in frequency control and an integration function. These two features provide a very high overall stability and compensate for any drift within the speed controller.

A soft load / unload function is also provided. When activated, the T4400 will

slowly increase or decrease speed to transfer load to or from the generator. A built-in relay can automatically trip the circuit breaker when the unload procedure is completed.

The T4400 has a built-in reverse power protection with selectable limits and time delays.

Fig. 1 shows how to connect to most Woodward and Heinzmann speed controllers. For connection to other makes please refer to the section "Interfacing" on the following page.

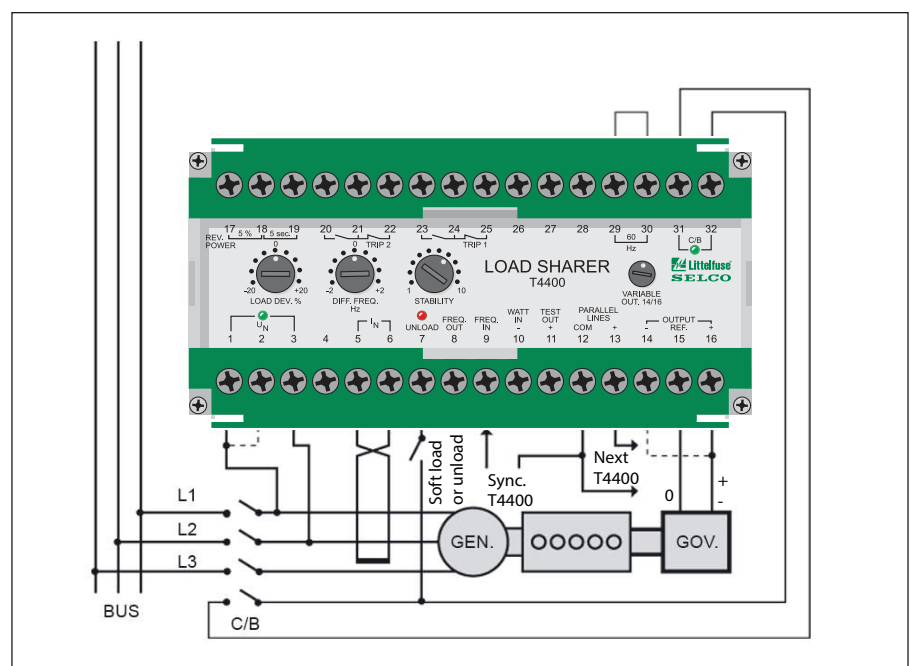

Fig. 1. Application diagram for T4400 and speed controller with -5V to +5V DC input.

### Supply voltage / current

The supply voltage from L1 and L2 is connected to terminals 1 and 3 or 2 and 3, depending on the system voltage.

The measuring current from L3 is connected to terminals 5 and 6 with 5 referring to the generator (see the application diagram on page 3). The current measurement must be taken from the same phase on all generators.

The current is measured in the phase that is not supplying the unit. It is important to ensure that the phase sequence is correct.

This relation between the connections of voltage and current must be correct in order to achieve a correct load measurement. It can be checked on terminal 11 (TEST OUT), where an input of nominal current (1A or 5A) and power factor 1.0 gives +6V for correct connection.

### Ramp function

The T4400 includes a ramp function. With this function activated, the unit will smoothly take over the load up to load balance.

In order to activate this function, terminals 7 (UNLOAD) and 32 should initially be bridged and so should terminals 31 (C/B) and 32 (for example with an aux. contact of the circuit breaker). Now the ramp function can be activated by opening the connection between terminals 7 (UNLOAD) and 32.

### Common reference

Terminal 12 (COM.) is the common reference for terminals 8 to 13.

### Unload facility

The unload facility will smoothly unload the generator. This facility works like an inverted ramp function. If activated, the load on the generator will be reduced and *maintained* at a low level.

In order to activate, terminals 31 (C/B) and 32 should initially be bridged. The unload function is then activated by connecting terminal 7 (UNLOAD) to 32.

### Unload trip

When the load passes below 5% load, a trip signal is provided as a normally open (NO) contact on terminal 20-21 and a normally closed (NC) contact on 21-22. This trip signal can be used to trip the circuit breaker.

### Reverse power trip

The reverse power trip operates at 10% with a delay of 10 sec., but it can be reduced to 5% by bridging terminals 17 and 18 and to 5 sec. delay by bridging 18 and 19. A resistor of 510k $\Omega$  between 17 and 18 gives 7.5%, a resistor of 2.7M $\Omega$  between 18 and 19 gives 7.5 sec. delay. The trip signal is provided as a normally open (NO) contact on term. 23-24 and a normally closed (NC) contact on 24-25.

### Frequency control

The electronic speed controller will control the frequency of the generator. However, the frequency control of some speed controllers will drift with time. In order to compensate for this, the T4400 includes frequency control.

The system frequency can be set to 60Hz with terminals 29 and 30 bridged or 50Hz with these terminals open. Further adjustment of the frequency is possible using the potentiometer DIFF. FREQ. on the front panel.

Connecting terminal 8 (FREQ. OUT) to 12 will disable the frequency control. This is used when running parallel with the grid, where the frequency is fixed by the grid.

### Input from synchronizer

Between terminals 9 (FREQ. IN) and 12 the SELCO T4000 Auto Synchronizer or most other synchronizer makes can be connected. The synchronizer will then give the synchronizing output through the T4400. This signal is not affected by the output adjustments on the T4400.

### External power measurement

Between terminals 10 (WATT IN) and 12 a negative voltage (0 to -1V DC from a watt converter) can be connected to substitute the internal load measuring circuit. In this case no input on terminals 5 and 6 is needed. Most standard measuring signals can be adapted with external resistors.

0-10V : series resistor 510k $\Omega$

0-5mA : parallel resistor 200 $\Omega$

### Communication between load sharers

For communication between the load sharers all terminals 12 (COM.) are interconnected, as well as all terminals 13 (+).

### Output to the speed controller

Output to the electronic speed controller is taken from terminals 15 (REF.) and 16 (+) with terminal 15 as reference. If an

inverse signal is needed, use terminals 15 (REF.) and 14 (-) rather than changing wires to 15 and 16. The output signal is an integrated signal. This means, the output signal will change as long as there is a load deviation. When load balance is obtained the output signal will stay at its current level.

### Adjustments

LOAD DEV. can be used for fine adjustments of the load balance. LOAD DEV. should also be used to obtain balance with generators of different size and with different types of current transducers (CTs). For generators of same size and with same type of CT, the setting 0 should be used on all load sharers.

DIFF. FREQ. is used for adjustment of system frequency as described on page 2 in the section about frequency control. If the system frequency should be exactly 50 Hz or 60 Hz, the setting 0 should be used.

STABILITY is used for adjusting the regulation time. A high setting of STABILITY will give a slow but accurate regulation. A low setting will give a fast regulation. However, a too low setting may cause instability.

VARIABLE OUT is intended for adjusting the size of the output signal to the speed controller. The output increases with higher setting on the potentiometer. Too much output can result in instability. If this is the case, turn the potentiometer anti clockwise until stability is restored.

### Interfacing

A detailed note on interfacing the T4000 and the T4400 to a wide number of different electronic speed controllers is available from SELCO. This note can also be downloaded from our web-site [www.selco.com](http://www.selco.com).

### Trouble Shooting

#### If load balance is not obtainable

If load balance is not obtainable and the power goes to maximum or reverse power, one of the signals is inverted due to wrong polarity or interchanged wires. If this is the case, the following should be checked:

1. The polarity of the power measuring signals on terminal 11 (TEST OUT) must be positive with the generator on load. If the polarity is negative, change the voltage connections 1 and 3 or 2 and 3 or the current connections 5 and 6.

- Output from terminals 15 (REF) and 16 (+) must be connected to the speed controller input. Terminal 16 is going positive for increased load. If a negative voltage for increased load is needed, then terminal 14 (-) should be used rather than terminal 16 (+).
- The parallel lines connected to terminals 12 (COM.) and 13 (+) between load sharers must not be interchanged.

**If the load balance is incorrect**

If there is a balance point, but the load balance is incorrect, the following should be checked:

- Load deviation shall be set to 0 for same size of generators and same type of current transducers (CTs).
- The frequency of the generators before paralleling should be the same.
- The output adjustment must have the same setting on all load sharers.
- If the deviation from other generators is approximately two times, it is likely that the current on terminals 5 and 6 is measured in one of the phases supplying the T4400. The current must be measured in the phase that is not supplying the unit (see the application diagram in fig. 1).

Check the voltage on terminal 11 (TEST OUT) to be +6V DC for nominal current input ( $I_N=1A$  or  $I_N=5A$ ) and power factor = 1.0. A current measurement in a wrong phase will give +3V DC.

**Example:**

If the current in terminals 5 and 6 is 2.0A, the nominal current  $I_N$  is 5A, and the power factor is 0.8, then the voltage for correct connection is:

$$6 \times \frac{2}{5} \times 0.8 = +1.9V.$$

**If the load is fluctuating up and down**

If there is a correct balance point, but the load is fluctuating up and down, the STABILITY should be turned clockwise in order to obtain stability, but not more than necessary.

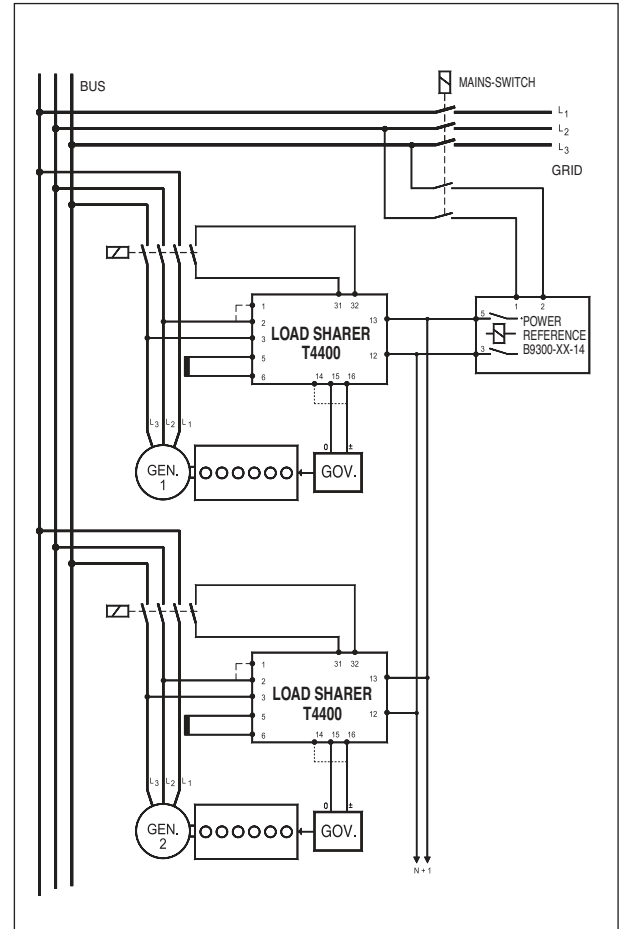

Fig. 2. Application Diagram: B9300 with T4400.

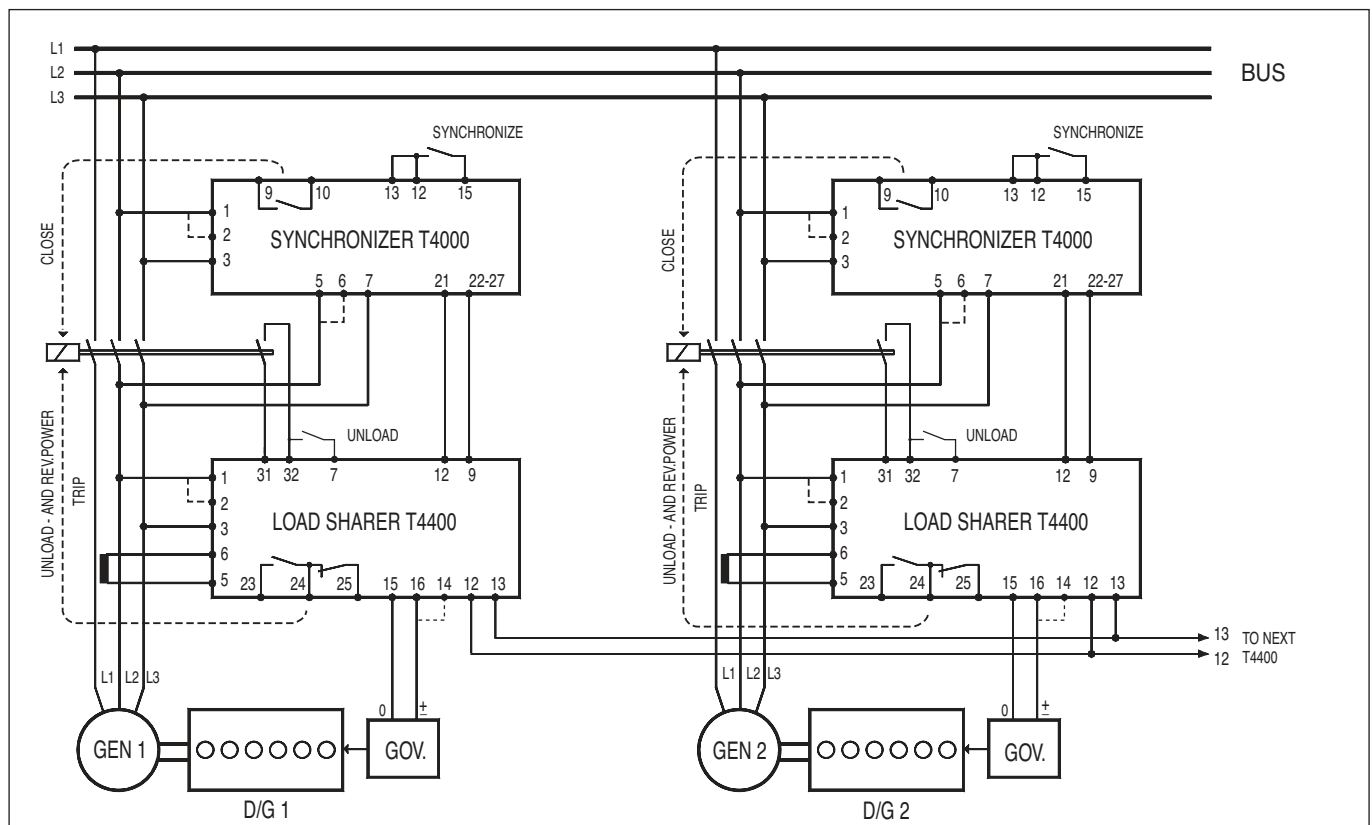

Fig. 3. Application Diagram. Synchronization and load sharing with the T4000, T4400 and a speed controller with -5V to +5V DC input.

# Specifications

## T4400 Load Sharer

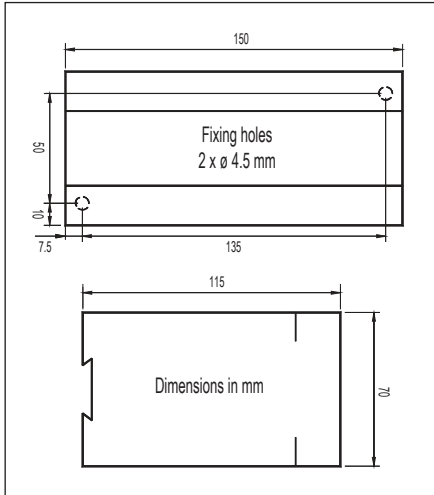

Fig. 4. Dimensions.

### Type Approvals and Certificates

The T4400 has been designed and tested for use in harsh environments. The unit is based on standard components, providing long term durability.

The T4400 carries the CE label and has been approved by the Russian Maritime Register of Shipping.



<b>Max voltage</b>	660V
<b>Voltage range</b>	70 - 110%
<b>Consumption</b>	Voltage 4VA at $U_N$ Current 0.4VA at $I_N$
<b>Continuous current</b>	$2 \times I_N$
<b>Frequency range</b>	35 - 70Hz
<b>Output voltage</b>	Max. $\pm 6V$ DC
<b>Contact rating</b>	AC: 400V, 2A, 250VA DC: 110V, 2A, 100W
<b>Operating temperature</b>	-20°C to +70°C
<b>EMC</b>	CE according to EN50081-1, EN50082-1, EN50081-2, EN50082-2, EN61000/6/2:1999
<b>Approvals</b>	Certified by the Russian Maritime Register of Shipping
<b>Burn-in</b>	50 hours before final test
<b>Enclosure material</b>	Polycarbonate, flame retardant
<b>Weight</b>	0.7kg
<b>Dimensions</b>	70 x 150 x 115mm (H x W x D)
<b>Installation</b>	35 DIN rail or two 4mm (3/16") screws

The specifications are subject to change without notice.

### Type Description

Type	Terminals		
	1-3	2-3	$I_N$
T4400.0010	450V	400V	5A
T4400.0020	230V		5A
T4400.0030	480V	415V	5A
T4400.0040	110V	100V	1A
T4400.0050	450V	400V	1A
T4400.0060	127V	120V	5A
T4400.0070	110V	100V	5A

Other supply voltages, nominal currents and combinations are available on request.

Main office:  
SELCO A/S  
Betonvej 10  
DK-4000 Roskilde  
Denmark  
Phone: + 45 7026 1122  
Fax: + 45 7026 2522  
e-mail: selco.dk@selco.com  
www.selco.com