

WORLD-BEAM® QS18LD Laser Diffuse Series Sensors



Datasheet



- Visible Class 1 laser
- Visible Class 1 laser for diffuse sensing
- Narrow effective beam provides small-object detection and precise position control
- Crosstalk rejection algorithm protects against optical disturbance from adjacent sensors
- Excellent optical performance throughout sensing range, even close up
- 10 V dc to 30 V dc operation, with complementary (SPDT) NPN or PNP outputs, depending on model
- Bright LED operating status indicators are visible from 360°
- Compact, rugged sealed housing, protected circuitry
- Mounting versatility – popular 18 mm threaded barrel or side-mount
- Choose 2 m (6.5 ft) or 9 m (30 ft) cable or one of four QD options



WARNING: Not To Be Used for Personnel Protection

Never use this device as a sensing device for personnel protection. Doing so could lead to serious injury or death. This device does not include the self-checking redundant circuitry necessary to allow its use in personnel safety applications. A sensor failure or malfunction can cause either an energized or de-energized sensor output condition.

Models

Model	Sensing Range	Spot Size at Focus	Cable	Output
QS18VN6LD	650 nm Visible Red Class 1 Laser 300 mm (12 in)	Approximately 1 mm at 300 mm (0.039 in at 12 in)	4-wire, 2 m (6.5 ft) integral cable	NPN
QS18VP6LD				PNP

Integral 2 m (6.5 ft) unterminated cable models are listed. To order the 9 m (30 ft) PVC cable model, add the suffix "W/30" to the cabled model number. For example, QS18VN6LD W/30. Models with a quick disconnect require a mating cordset. To order the QD models:

- To order the 4-pin M12/Euro-style integral quick disconnect model, add the suffix "Q8" to the model number. For example, QS18VN6LDQ8.
- To order the 4-pin M8/Pico-style integral quick disconnect model, add the suffix "Q7" to the model number. For example, QS18VN6LDQ7
- To order the 150 mm (6 in) PVC cable model with a 4-pin M12/Euro-style quick disconnect, add the suffix "Q5" to the model number. For example, QS18VN6LDQ5.
- To order the 150 mm (6 in) PVC cable model with a 4-pin M8/Pico-style quick disconnect, add the suffix "Q" to the model number. For example, QS18VN6LDQ.

Wiring Diagrams

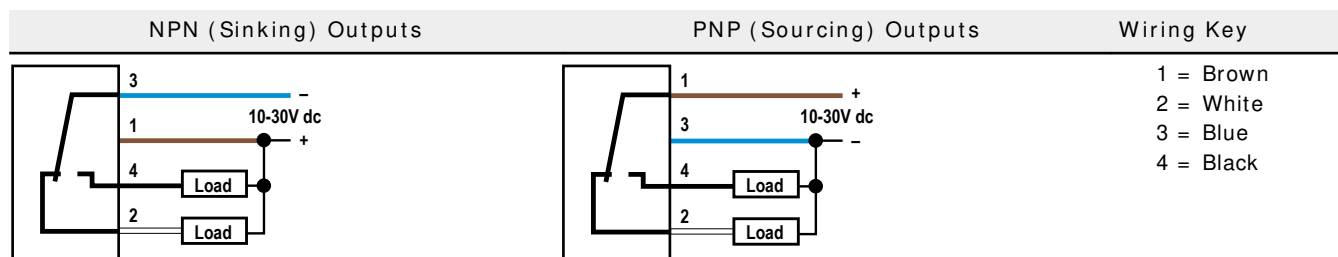

Cabled wiring diagrams are shown. Quick disconnect (QD) wiring diagrams are functionally identical.



Specifications

Supply Voltage
10 to 30 V dc (10% maximum ripple) at less than 15 mA, exclusive of load

Sensing Beam
Visible red LED, 650 nm

Laser Characteristics
Wavelength: 650 nm visible red Class 1 laser
Pulse Width: 7 microseconds
Rep Rate: 130 microseconds
Average Output Power: 0.065 mW

Supply Protection Circuitry
Protected against reverse polarity and transient voltages

Output Configuration
Solid-state complementary (SPDT): NPN or PNP (current sinking or sourcing), depending on model;
Rating: 100 mA maximum each output at 25 °C
Off-state leakage current:
NPN: less than 200 µA at 30 V dc (See Application Note 1)
PNP: less than 10 µA at 30 V dc
ON-state saturation voltage:
NPN: less than 1.6 V at 100 mA
PNP: less than 3.0 V at 100 mA

Output Protection Circuitry
Protected against false pulse on power-up and continuous overload or short circuit of outputs

Laser Classification
Class 1 laser product; Complies with IEC 60825-1:2001 and 21 CFR 1040.10, except for deviations pursuant to Laser Notice 50, dated 7-26-01

Environmental Ratings
IEC IP67; NEMA 6; UL Type 1

Operating Conditions
-10 °C to +50 °C (+ 14 °F to + 122 °F)
95% at +50 °C maximum relative humidity (non-condensing)

Application Notes
NPN off-state leakage current is < 200 µA for load resistances > 3 kΩ or optically isolated loads. For load current of 100 mA, leakage is < 1% of load current.

Certifications



Output Response
700 microseconds ON/OFF
Note: 200 millisecond delay on power-up; outputs do not conduct during this time

Repeatability
130 microseconds

Sensing Hysteresis
15% of range typical

Adjustments
Single-turn sensitivity (Gain) adjustment potentiometer

Indicators
2 LED indicators on sensor top:
Green solid: Power on
Amber solid: Light sensed
Amber flashing: Marginal excess gain (1 to 1.5x excess gain)

Construction
ABS housing, acrylic lens cover, 3 mm mounting hardware included

Connections
2 m (6.5 ft) 4-wire PVC cable, 9 m (30 ft) 4-wire PVC cable, 4-pin Pico-style or Euro-style QD, 4-pin Pico-style or Euro-style 150 mm (6 in) pigtail QD, depending on model

Required Overcurrent Protection



WARNING: Electrical connections must be made by qualified personnel in accordance with local and national electrical codes and regulations.

Overcurrent protection is required to be provided by end product application per the supplied table.
Overcurrent protection may be provided with external fusing or via Current Limiting, Class 2 Power Supply.
Supply wiring leads < 24 AWG shall not be spliced.
For additional product support, go to www.bannerengineering.com.

Supply Wiring (AWG)	Required Overcurrent Protection (Amps)
20	5.0
22	3.0
24	2.0
26	1.0
28	0.8
30	0.5

Dimensions

All measurements are listed in millimeters [inches], unless noted otherwise.

Cabled Models

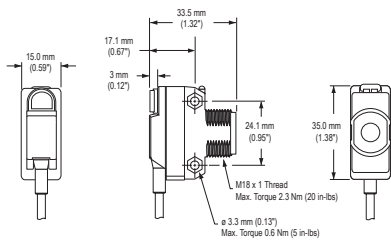

Pico-Style QD Models

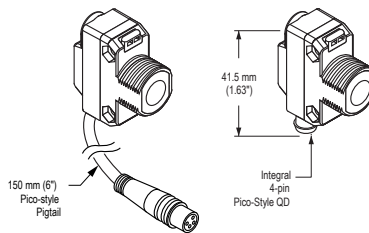

Euro-Style QD Models

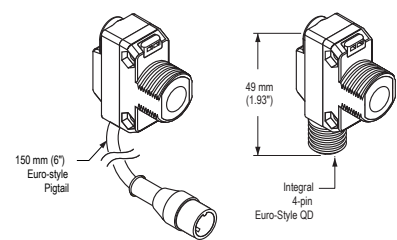

Locknut (included with all models)

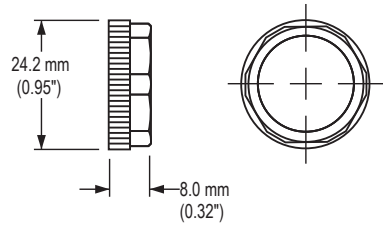

Washer (included with all models)

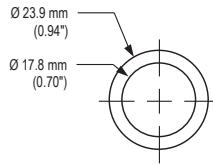

M3 Hardware Packet Contents:

- 2 – M3 x 0.5 x 20 mm SS Screw
- 2 – M3 x 0.5 SS Hex Nut
- 2 – M3 SS Washer

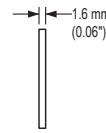

Performance Curves

Performance is based on a 90% reflectance white test card.

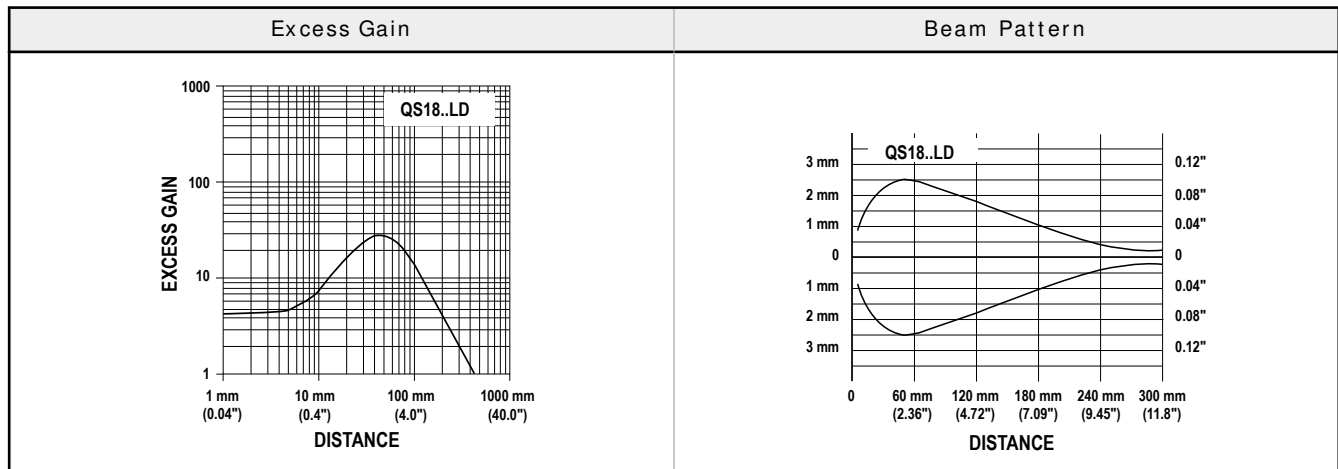

Description of Laser Classes

Class 1 Lasers

Class 1 lasers are lasers that are safe under reasonably foreseeable conditions of operation, including the use of optical instruments for intrabeam viewing.

Reference IEC 60825-1:2001, Section 8.2.

Class 1 Laser Characteristics: See Specifications.



CAUTION: Do Not Disassemble for Repair

This device contains no user-serviceable components. Do not attempt to disassemble for repair. Use of controls or adjustments or performance of procedures other than those specified herein may result in hazardous radiation exposure. A defective unit must be returned to the manufacturer.



For Safe Laser Use (Class 1 or Class 2):

- Do not stare at the laser.
- Do not point the laser at a person's eye.
- Mount open laser beam paths either above or below eye level, where practical.
- Terminate the beam emitted by the laser product at the end of its useful path.

Accessories

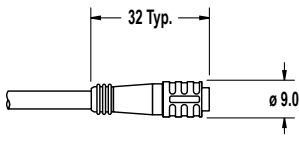
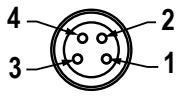
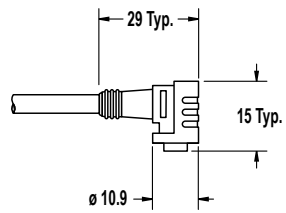
4-Pin Snap-on M8/ Pico-Style Cordsets				
Model	Length	Style	Dimensions	Pinout (Female)
PKG4-2	2 m (6.56 ft)	Straight		 <p>1 = Brown 2 = White 3 = Blue 4 = Black</p>
PKW4Z-2	2 m (6.56 ft)	Right-Angle		

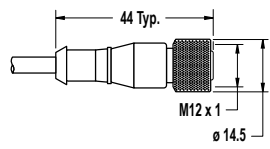
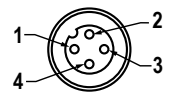
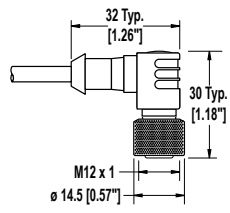
4-Pin Threaded M12/ Euro-Style Cordsets				
Model	Length	Style	Dimensions	Pinout (Female)
MQDC-406	1.83 m (6 ft)	Straight		 <p>1 = Brown 2 = White 3 = Blue 4 = Black</p>
MQDC-415	4.57 m (15 ft)			
MQDC-430	9.14 m (30 ft)			
MQDC-406RA	1.83 m (6 ft)	Right-Angle		
MQDC-415RA	4.57 m (15 ft)			
MQDC-430RA	9.14 m (30 ft)			
MQDC-450RA	15.2 m (50 ft)			

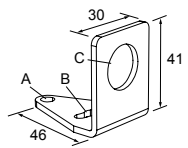
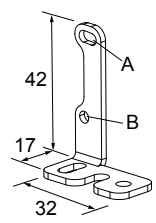
Mounting Brackets	
<p>SMB18A</p> <ul style="list-style-type: none"> Right-angle mounting bracket with a curved slot for versatile orientation 12-ga. stainless steel 18 mm sensor mounting hole Clearance for M4 (#8) hardware  <p>Hole center spacing: A to B = 24.2 Hole size: A = ø 4.6, B = 17.0 x 4.6, C = ø 18.5</p>	<p>SMBQS18RA</p> <ul style="list-style-type: none"> Right-angle mounting bracket 14-ga. 304 stainless steel  <p>Hole center spacing: A to B = 20.3 Hole size: A = 4.3 x 9.3, B = ø 4.3</p>

Mounting Brackets

SMB312S

- Stainless steel 2-axis, side-mount bracket

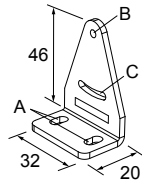

A = 4.3 x 7.5, B = diam. 3, C = 3 x 15.3

SMB18FA..

- Swivel bracket with tilt and pan movement for precision adjustment
- Easy sensor mounting to extruded rail T-slots
- Metric and inch size bolts available
- 18 mm sensor mounting hole

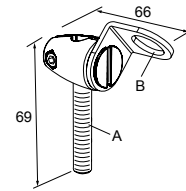

Hole size: B= ø 18.1

Model	Bolt Thread (A)
SMB18FA	3/8 - 16 x 2 in
SMB18FAM10	M10 - 1.5 x 50
SMB18FAM12	n/a; no bolt included. Mounts directly to 12 mm (½ in) rods

SMB46A

- 2-piece 12-ga. stainless steel bracket assembly with precision sensor alignment adjustment
- 2 mm hex key included

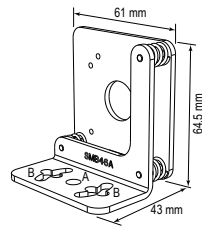

Hole center spacing: A to B = 18.5, B = 30.5
Hole size: A = ø 6.6, B = 7.1 x 20.3

SMBQS18Y

- Die-cast bracket for 18 mm holes
- Includes metal hex nut and lock washer
- Allows ± 8° for cabled sensors

Hole size: A = ø 15.3

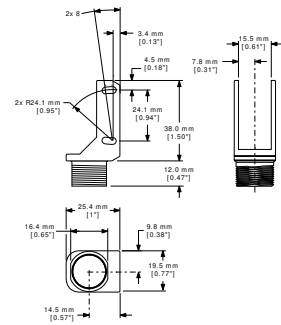

SMB18SF

- 18 mm swivel bracket with M18 x 1 internal thread
- Black thermoplastic polyester
- Stainless steel swivel locking hardware included

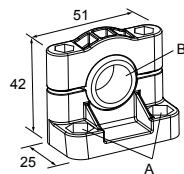

Hole center spacing: A = 36.0
Hole size: A = ø 5.3, B = ø 18.0

SMBQS18A

- Wrap-around protection bracket
- Die-cast bracket
- Base fits 18 mm threaded hole
- Metal hex nut, lock washer and grommet included
- Mounting holes specially designed for QS18AF sensors

Hole size: A = ø 15.3

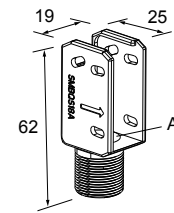

SMB3018SC

- 18 mm swivel side or barrel-mount bracket
- Black reinforced thermoplastic polyester
- Stainless steel swivel locking hardware included

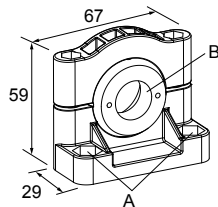

Hole center spacing: A = 50.8
Hole size: A = ø 7.0, B = ø 18.0

Banner Engineering Corp. Limited Warranty

Banner Engineering Corp. warrants its products to be free from defects in material and workmanship for one year following the date of shipment. Banner Engineering Corp. will repair or replace, free of charge, any product of its manufacture which, at the time it is returned to the factory, is found to have been defective during the warranty period. This warranty does not cover damage or liability for misuse, abuse, or the improper application or installation of the Banner product.

THIS LIMITED WARRANTY IS EXCLUSIVE AND IN LIEU OF ALL OTHER WARRANTIES WHETHER EXPRESS OR IMPLIED (INCLUDING, WITHOUT LIMITATION, ANY WARRANTY OF MERCHANTABILITY OR FITNESS FOR A PARTICULAR PURPOSE), AND WHETHER ARISING UNDER COURSE OF PERFORMANCE, COURSE OF DEALING OR TRADE USAGE.

This Warranty is exclusive and limited to repair or, at the discretion of Banner Engineering Corp., replacement. IN NO EVENT SHALL BANNER ENGINEERING CORP. BE LIABLE TO BUYER OR ANY OTHER PERSON OR ENTITY FOR ANY EXTRA COSTS, EXPENSES, LOSSES, LOSS OF PROFITS, OR ANY INCIDENTAL, CONSEQUENTIAL OR SPECIAL DAMAGES RESULTING FROM ANY PRODUCT DEFECT OR FROM THE USE OR INABILITY TO USE THE PRODUCT, WHETHER ARISING IN CONTRACT OR WARRANTY, STATUTE, TORT, STRICT LIABILITY, NEGLIGENCE, OR OTHERWISE.

Banner Engineering Corp. reserves the right to change, modify or improve the design of the product without assuming any obligations or liabilities relating to any product previously manufactured by Banner Engineering Corp. Any misuse, abuse, or improper application or installation of this product or use of the product for personal protection applications when the product is identified as not intended for such purposes will void the product warranty. Any modifications to this product without prior express approval by Banner Engineering Corp will void the product warranties. All specifications published in this document are subject to change; Banner reserves the right to modify product specifications or update documentation at any time. Specifications and product information in English supersede that which is provided in any other language. For the most recent version of any documentation, refer to: www.bannerengineering.com.