

LOWER ROW

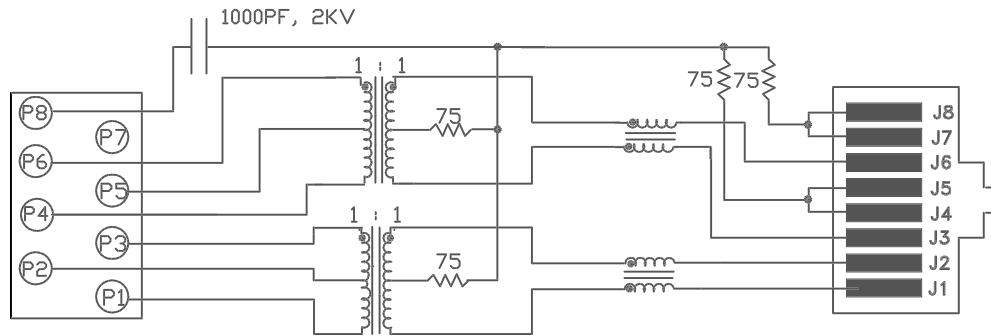

UPPER ROW

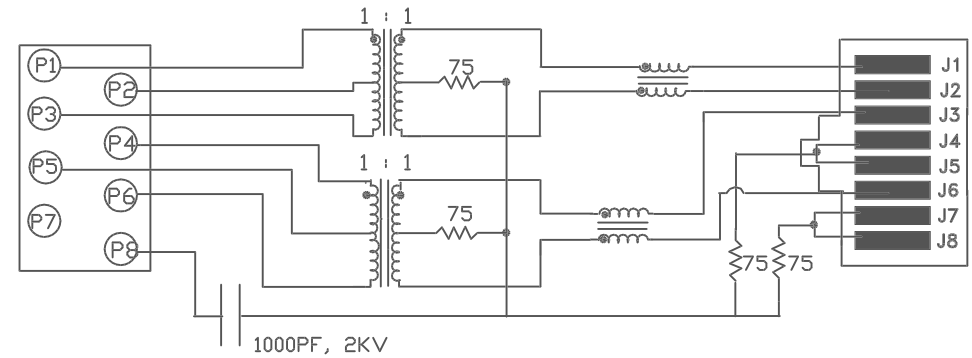

ELECTRICAL SPECIFICATIONS:

1.0 TURNS RATIO (P1-P2-P3) : (J1-J2)	: 1CT : $1 \pm 3\%$
(P4-P5-P6) : (J3-J6)	: 1CT : $1 \pm 3\%$
2.0 INDUCTANCE (P6-P4)	: 350uH MIN. @ 0.1V , 100KHz, 8mA DC Bias
(P3-P1)	: 350uH MIN. @ 0.1V, 100KHz, 8mA DC Bias
3.0 LEAKAGE INDUCTANCE P6-P4 (WITH J6 AND J3 SHORT)	: 0.3uH MAX. @ 1MHz
P3-P1 (WITH J2 AND J1 SHORT)	: 0.3uH MAX. @ 1MHz
4.0 INTERWINDING CAPACITANCE (P6,P5,P4) TO (J6,J3)	: 25pf TYP @ 1MHz
(P3,P2,P1) TO (J2,J1)	: 25pf TYP @ 1MHz
5.0 DC RESISTANCE (J6-J3)=(J1-J2)	: 1.2 ohms Max.
(P6-P4)	: .7 ohms Max.
(P3-P1)	: .7 ohms Max.

NOTES

1.0 PINS WITHOUT ELECTRICAL CONNECTION ARE OMITTED.

InNet Technologies Inc.

<http://www.innet-tech.com>

Stewart Connector Systems

<http://www.stewartconnector.com>

SHEET
1 of 4

DRAWING NO. SI-30006 REV. 02

6.0 RETURN LOSS:

1MHz TO 30MHz : 18dB MIN.
60MHz TO 80MHz : 12dB MIN.

7.0 VOLTAGE WITHSTAND:

(J1, J2) TO (P1, P2) : 1500 VAC
(J3, J6) TO (P3,P6) : 1500 VAC

8.0 INSERTION LOSS:

100KHz TO 100MHz : 1.1 dB TYP

9.0 RISE TIME:

OUTPUT VOLTAGE = 1 V peak : 3.0 nS TYP
PULSE WIDTH= 112nS : 3.0 nS TYP

10.0 CROSS TALK:

1MHz TO 100MHz : 40 dB TYP

11.0 COMMON TO COMMON MODE ATTENUATION:

1MHz TO 100MHz : 35dB TYP

InNet Technologies Inc.

<http://www.innet-tech.com>

Stewart Connector Systems

<http://www.stewartconnector.com>

SHEET
2 of 4

DRAWING NO. SI-30006 REV. 02

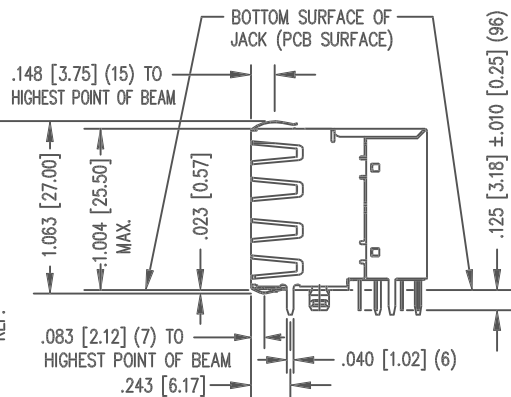
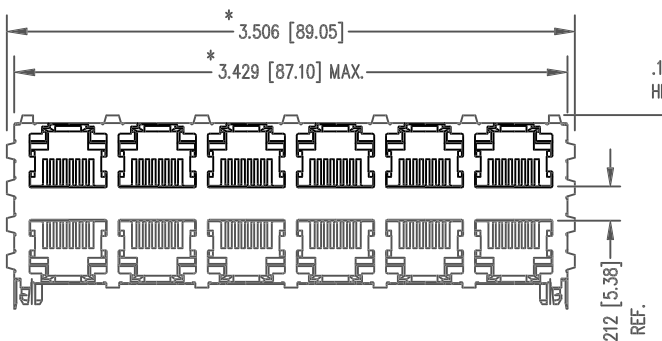
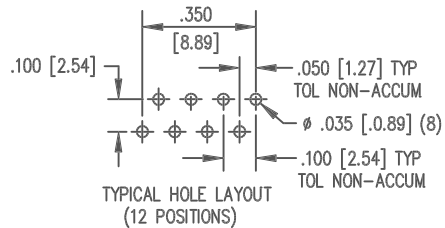
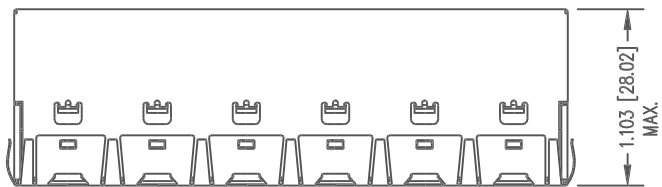

NOTES:

- TOLERANCES COMPLY WITH F.C.C. DIMENSION REQUIREMENTS.
- DIMENSIONS SHOWN WITH "*" TO BE CENTRAL ABOUT THE CENTER LINE.
- PINS NOT ELECTRICALLY CONNECTED MAYBE OMITTED. SEE ELECTRICAL DRAWING FOR OMITTED PINS.

AVAILABLE WITH:

- STANDARD 50 MICRO-INCH SELECTIVE GOLD PLATING.

REF : SS-723-PG4

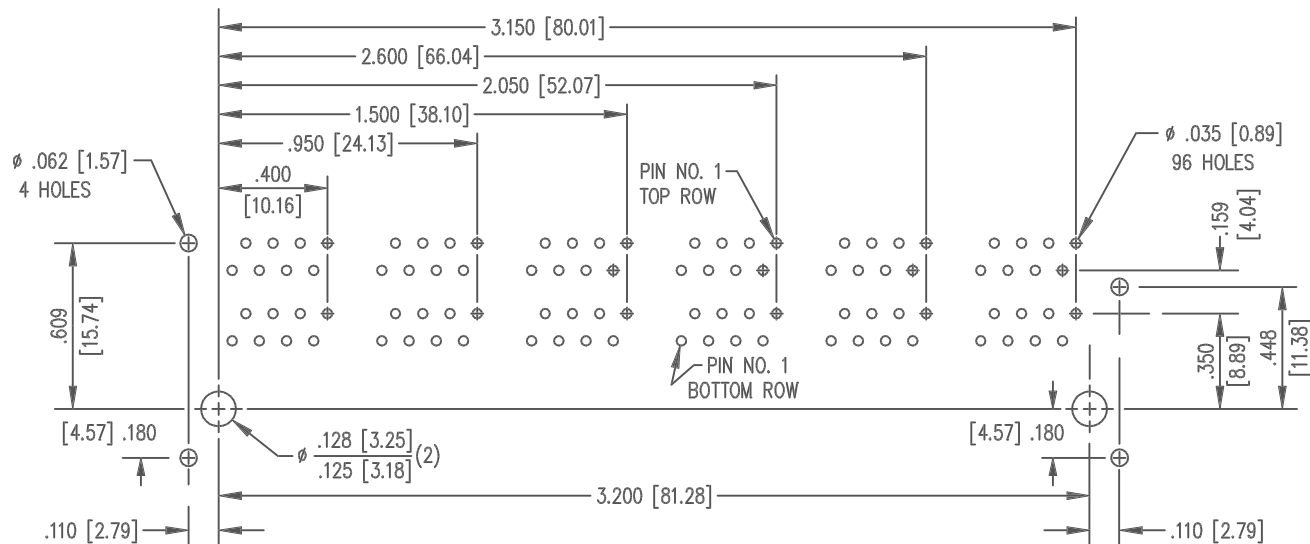

P.C.B. RECOMMENDED HOLE LAYOUT
SEEN FROM COMPONENT SIDE
TOLERANCE ±.003 [0.08] UNLESS OTHERWISE SPECIFIED

InNet Technologies Inc.

<http://www.innet-tech.com>

Stewart Connector Systems

<http://www.stewartconnector.com>

SHEET

3 OF 4

DRAWING NO.

SI-30006

REV.

03

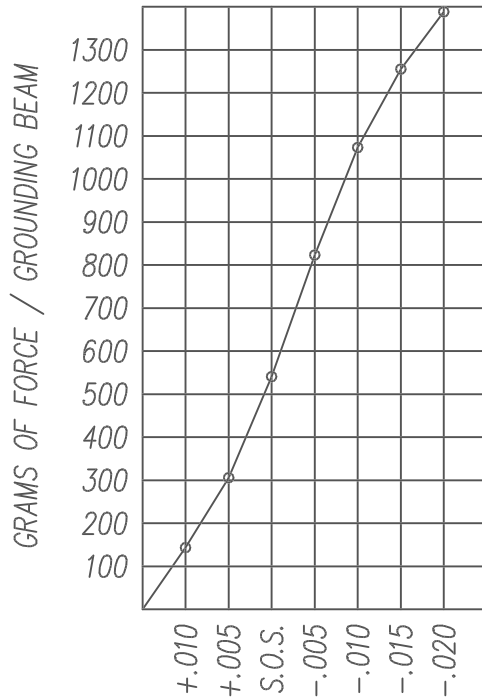

PANEL GROUNDING BEAM DEFLECTION
TOP AND SIDE BEAMS
S.O.S. = SUGGESTED OPENING SIZE

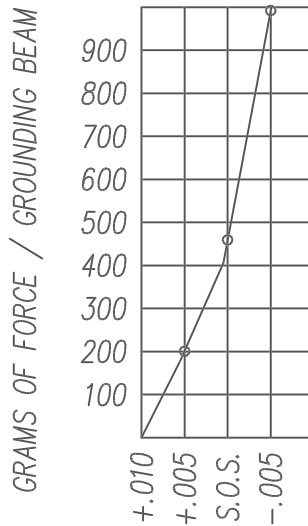

PANEL GROUNDING BEAM DEFLECTION
BOTTOM BEAMS ONLY
S.O.S. = SUGGESTED OPENING SIZE

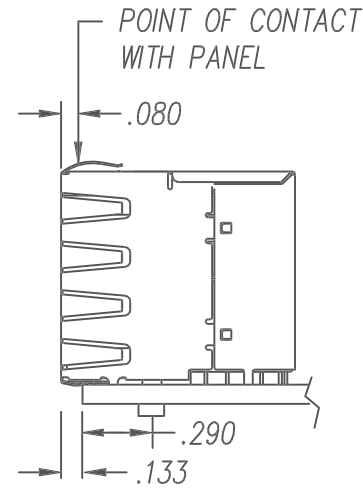

THE SUGGESTED PANEL OPENING IS INTENDED TO GIVE THE USER THE ABILITY TO HAVE REASONABLE JACK / PANEL CLEARANCES YET MAINTAIN RELIABLE GROUNDING CAPABILITY. THESE VARIABLES CAN BE ADJUSTED IN EITHER DIRECTION BUT MAY CARRY SOME CONSEQUENCES IN THE FORM OF LOWER MATING FORCES OR TIGHTER ASSEMBLY TOLERANCES. FORCE VALUES ON THE GRAPH(S) ARE GENERAL AVERAGES TAKEN AT A POINT OF CONTACT SHOWN ABOVE. THE SUGGESTED PANEL OPENING INCLUDES APPROXIMATELY .020 CLEARANCE ON THE TOP AND SIDES, WITH .015 CLEARANCE ON THE BOTTOM.

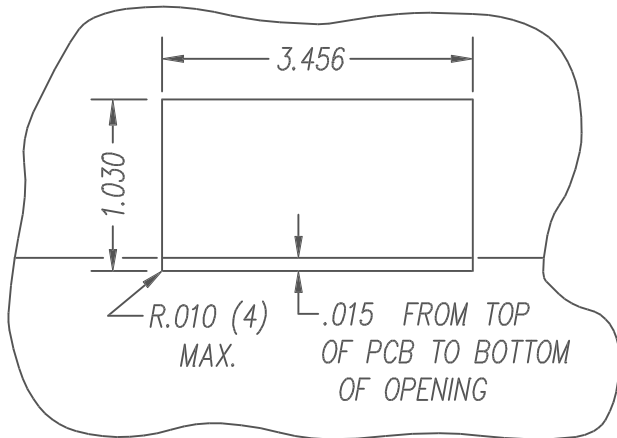

SUGGESTED PANEL OPENING
(N.T.S.)

InNet Technologies Inc.
<http://www.innet-tech.com>
Stewart Connector Systems
<http://www.stewartconnector.com>

SHEET
4 OF 4

DRAWING NO. SI-30006 REV. 03