

CUSTOMER DRAWING

REVISIONS					
REV#	ECN#	REVISION ACTION	REV.BY:	APPR.BY:	DATE
A	--	INITIAL RELEASE	Fred	JL	10/21/2020
B	--	Add dust cap, oring and M6 PM8 specifications	Star	James	12/30/2020

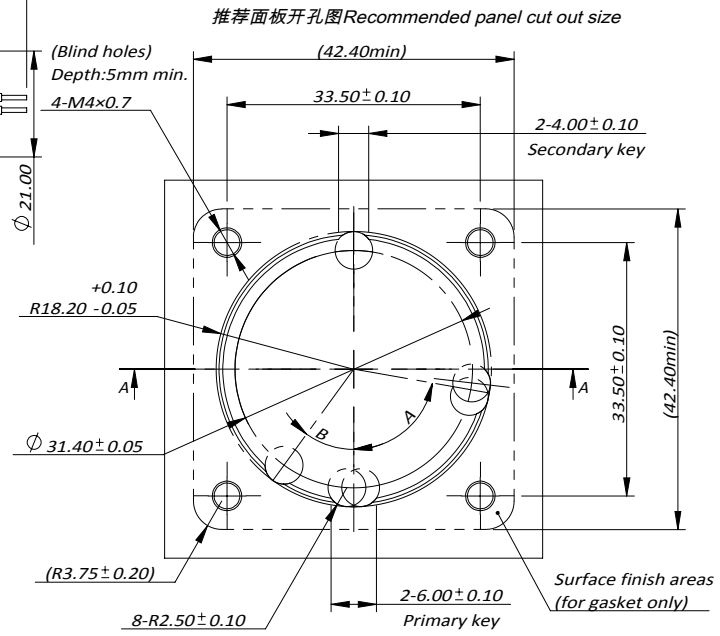

键位 Key	A	B
X	80°	36°
Y	50°	86°
U	36°	76°
V	100°	56°
W	130°	60°
T	144°	96°

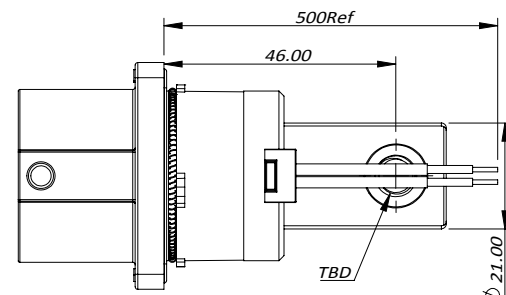
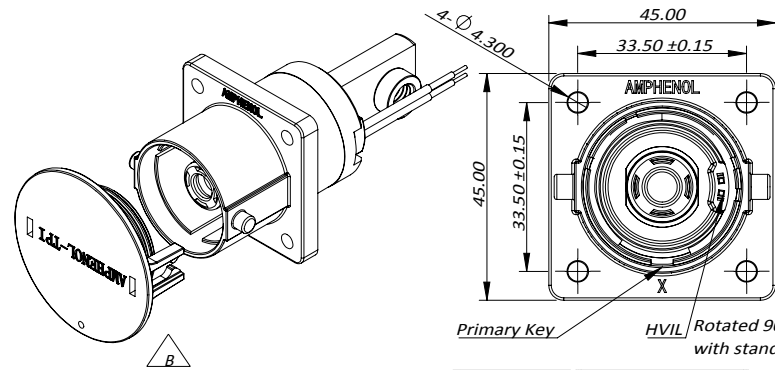
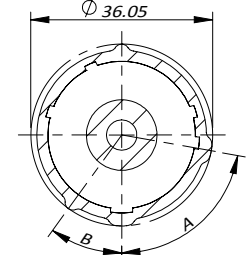
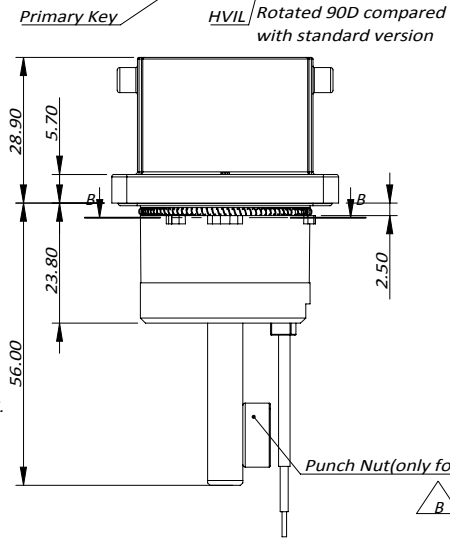

剖面 B-B
比例 1 : 1.5

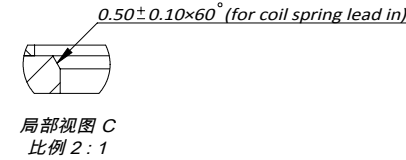

局部视图 C
比例 2 : 1

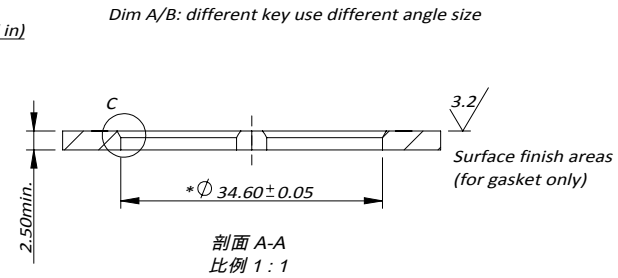

剖面 A-A
比例 1 : 1

规格参数(Spec.):

1. 工作温度 Operating temperature : -40°C ~ +125°C.
2. 带高压互锁 Electrical interlock (HVIL).
3. 额定电流 Current rating:
Power: 500A; HVIL: 5A.
4. 额定电压 Operating voltage:
Power: 1000 VDC; Signal: 60 VDC.
5. 耐压 Dielectric withstanding voltage:
A. 与插头对插后, Pin与铁壳之间
When mated, between pin and metal shell: 5000 VDC.
B. 与插头对插后, Pin与HVIL之间
When mated, between pin and HVIL: 5000 VDC.
C. 与插头对插后, HVIL与铁壳之间
When mated, between HVIL and metal shell: 500 VDC.
D. 与插头对插前, 两个HVIL端子之间耐压
Before mating, between two HVIL terminals: 500 VDC.
6. 防护等级 Protection class: Mated-IP6k9k & IP67, unmated-IP2X.
7. 电磁屏蔽 360° full Shielding.
8. 机械寿命 Mating cycle: 100 Min.
9. 绝缘材料满足 UL94V-0 Inner insulation material satisfy UL94V-0.
10. 推荐法兰盘螺丝安装扭矩 Recommended Screw Assembly Torque on Flange : 1.6~2.4Nm
11. 推荐铜排安装扭矩 Recommended Fasten Torque on Lug:
M6: 3.6~4.4Nm, M8: 7.2~8.8Nm, M10: 17.1~20.9Nm
12. 镀灰锌/镍合金, 符合RoHS, 满足500H中性盐雾实验
Gray Zinc/Nickel(ZnNi)Plating, RoHS compliant, Rated at 500hours salt spray.

订购信息 Ordering Information

PL 00 X - 50X - 90X X - 2

Key and Color	HVIL	Hole Type	Hole Size
"X", Orange	"0", NO HVIL	"D", Through Hole	"D", Through Hole
"Y", Black	"1", With HVIL	"M", thread hole	"M", thread hole
"U", Yellow		"H", slot hole	"H", slot hole
"V", Green		"PM", Punch Nut	"PM", Punch Nut
"W", Red			
"T", Blue			

	Amphenol Technical Products International Asia.					
	第三角投影 THIRD ANGLE PROJECTION	页面 SHEET	幅面 SIZE	版次 REV.	比例 SCALE	PART NAME: PL14mm G2 Rcpt Lug 90Degree
签名 SIGNATURE	日期 DATE	UNLESS OTHERWISE SPECIFIED 1) All dimensions are in metric(mm). 2) Tolerances are as follows: 1.PL DEC ± 1.00 2.PL DEC ± 0.50 3.PL DEC ± 0.20			DWG NO: PL00X-50X-90XX-2	CUST PART #
制图 DRAWN	审核 CHECKED	批准 APPROVAL	Star	12/30/2020	Angles ±1°	CUST REV.

THIS DRAWING IS SUPPLIED FOR INFORMATION ONLY. DESIGN FEATURES, SPECIFICATIONS AND PERFORMANCE DATA SHOWN HEREON ARE THE PROPERTY OF THE AMPHENOL CORPORATION. NO RIGHTS OF REPRODUCTION ARE IMPLIED. ALL DIMENSIONS ARE SUBJECT TO NORMAL MANUFACTURING VARIATIONS.

THIS DRAWING IS SUPPLIED FOR INFORMATION ONLY. DESIGN FEATURES, SPECIFICATIONS AND PERFORMANCE DATA SHOWN HEREON ARE THE PROPERTY OF THE AMPHENOL CORPORATION. NO RIGHTS OF REPRODUCTION ARE IMPLIED. ALL DIMENSIONS ARE SUBJECT TO NORMAL MANUFACTURING VARIATIONS.

1	2	3	4	5	6	7	8																																																																																																																																																																										
<table border="1" style="width:100%; border-collapse: collapse;"> <thead> <tr> <th>型号 Model</th> <th>AC P/N</th> </tr> </thead> <tbody> <tr><td>PL00X-500-90M8-2</td><td>AC-HA014517</td></tr> <tr><td>PL00Y-500-90M8-2</td><td>AC-HA014518</td></tr> <tr><td>PL00U-500-90M8-2</td><td>AC-HA014519</td></tr> <tr><td>PL00V-500-90M8-2</td><td>AC-HA014520</td></tr> <tr><td>PL00W-500-90M8-2</td><td>AC-HA014521</td></tr> <tr><td>PL00T-500-90M8-2</td><td>AC-HA014522</td></tr> <tr><td>PL00X-500-90M10-2</td><td>AC-HA014523</td></tr> <tr><td>PL00Y-500-90M10-2</td><td>AC-HA014524</td></tr> <tr><td>PL00U-500-90M10-2</td><td>AC-HA014525</td></tr> <tr><td>PL00V-500-90M10-2</td><td>AC-HA014526</td></tr> <tr><td>PL00W-500-90M10-2</td><td>AC-HA014527</td></tr> <tr><td>PL00T-500-90M10-2</td><td>AC-HA014528</td></tr> <tr><td>PL00X-500-90D8-2</td><td>AC-HA014529</td></tr> <tr><td>PL00Y-500-90D8-2</td><td>AC-HA014530</td></tr> <tr><td>PL00U-500-90D8-2</td><td>AC-HA014531</td></tr> <tr><td>PL00V-500-90D8-2</td><td>AC-HA014532</td></tr> <tr><td>PL00W-500-90D8-2</td><td>AC-HA014533</td></tr> <tr><td>PL00T-500-90D8-2</td><td>AC-HA014534</td></tr> <tr><td>PL00X-500-90D10-2</td><td>AC-HA014535</td></tr> <tr><td>PL00Y-500-90D10-2</td><td>AC-HA014536</td></tr> <tr><td>PL00U-500-90D10-2</td><td>AC-HA014537</td></tr> <tr><td>PL00V-500-90D10-2</td><td>AC-HA014538</td></tr> <tr><td>PL00W-500-90D10-2</td><td>AC-HA014539</td></tr> <tr><td>PL00T-500-90D10-2</td><td>AC-HA014540</td></tr> <tr><td>PL00X-501-90M8-2</td><td>AC-HA014541</td></tr> <tr><td>PL00Y-501-90M8-2</td><td>AC-HA014542</td></tr> <tr><td>PL00U-501-90M8-2</td><td>AC-HA014543</td></tr> <tr><td>PL00V-501-90M8-2</td><td>AC-HA014544</td></tr> <tr><td>PL00W-501-90M8-2</td><td>AC-HA014545</td></tr> <tr><td>PL00T-501-90M8-2</td><td>AC-HA014546</td></tr> <tr><td>PL00X-501-90M10-2</td><td>AC-HA014547</td></tr> <tr><td>PL00Y-501-90M10-2</td><td>AC-HA014548</td></tr> <tr><td>PL00U-501-90M10-2</td><td>AC-HA014549</td></tr> <tr><td>PL00V-501-90M10-2</td><td>AC-HA014550</td></tr> <tr><td>PL00W-501-90M10-2</td><td>AC-HA014551</td></tr> <tr><td>PL00T-501-90M10-2</td><td>AC-HA014552</td></tr> <tr><td>PL00X-501-90D8-2</td><td>AC-HA014553</td></tr> <tr><td>PL00Y-501-90D8-2</td><td>AC-HA014554</td></tr> <tr><td>PL00U-501-90D8-2</td><td>AC-HA014555</td></tr> <tr><td>PL00V-501-90D8-2</td><td>AC-HA014556</td></tr> <tr><td>PL00W-501-90D8-2</td><td>AC-HA014557</td></tr> <tr><td>PL00T-501-90D8-2</td><td>AC-HA014558</td></tr> <tr><td>PL00X-501-90D10-2</td><td>AC-HA014559</td></tr> <tr><td>PL00Y-501-90D10-2</td><td>AC-HA014560</td></tr> <tr><td>PL00U-501-90D10-2</td><td>AC-HA014561</td></tr> <tr><td>PL00V-501-90D10-2</td><td>AC-HA014562</td></tr> <tr><td>PL00W-501-90D10-2</td><td>AC-HA014563</td></tr> <tr><td>PL00T-501-90D10-2</td><td>AC-HA014564</td></tr> </tbody> </table>		型号 Model	AC P/N	PL00X-500-90M8-2	AC-HA014517	PL00Y-500-90M8-2	AC-HA014518	PL00U-500-90M8-2	AC-HA014519	PL00V-500-90M8-2	AC-HA014520	PL00W-500-90M8-2	AC-HA014521	PL00T-500-90M8-2	AC-HA014522	PL00X-500-90M10-2	AC-HA014523	PL00Y-500-90M10-2	AC-HA014524	PL00U-500-90M10-2	AC-HA014525	PL00V-500-90M10-2	AC-HA014526	PL00W-500-90M10-2	AC-HA014527	PL00T-500-90M10-2	AC-HA014528	PL00X-500-90D8-2	AC-HA014529	PL00Y-500-90D8-2	AC-HA014530	PL00U-500-90D8-2	AC-HA014531	PL00V-500-90D8-2	AC-HA014532	PL00W-500-90D8-2	AC-HA014533	PL00T-500-90D8-2	AC-HA014534	PL00X-500-90D10-2	AC-HA014535	PL00Y-500-90D10-2	AC-HA014536	PL00U-500-90D10-2	AC-HA014537	PL00V-500-90D10-2	AC-HA014538	PL00W-500-90D10-2	AC-HA014539	PL00T-500-90D10-2	AC-HA014540	PL00X-501-90M8-2	AC-HA014541	PL00Y-501-90M8-2	AC-HA014542	PL00U-501-90M8-2	AC-HA014543	PL00V-501-90M8-2	AC-HA014544	PL00W-501-90M8-2	AC-HA014545	PL00T-501-90M8-2	AC-HA014546	PL00X-501-90M10-2	AC-HA014547	PL00Y-501-90M10-2	AC-HA014548	PL00U-501-90M10-2	AC-HA014549	PL00V-501-90M10-2	AC-HA014550	PL00W-501-90M10-2	AC-HA014551	PL00T-501-90M10-2	AC-HA014552	PL00X-501-90D8-2	AC-HA014553	PL00Y-501-90D8-2	AC-HA014554	PL00U-501-90D8-2	AC-HA014555	PL00V-501-90D8-2	AC-HA014556	PL00W-501-90D8-2	AC-HA014557	PL00T-501-90D8-2	AC-HA014558	PL00X-501-90D10-2	AC-HA014559	PL00Y-501-90D10-2	AC-HA014560	PL00U-501-90D10-2	AC-HA014561	PL00V-501-90D10-2	AC-HA014562	PL00W-501-90D10-2	AC-HA014563	PL00T-501-90D10-2	AC-HA014564	<table border="1" style="width:100%; border-collapse: collapse;"> <thead> <tr> <th>型号 Model</th> <th>AC P/N</th> </tr> </thead> <tbody> <tr><td>PL00X-500-90M6-2</td><td>AC-HA017798</td></tr> <tr><td>PL00Y-500-90M6-2</td><td>AC-HA017799</td></tr> <tr><td>PL00U-500-90M6-2</td><td>AC-HA017800</td></tr> <tr><td>PL00V-500-90M6-2</td><td>AC-HA017801</td></tr> <tr><td>PL00W-500-90M6-2</td><td>AC-HA017802</td></tr> <tr><td>PL00T-500-90M6-2</td><td>AC-HA017803</td></tr> <tr><td>PL00X-501-90M6-2</td><td>AC-HA017804</td></tr> <tr><td>PL00Y-501-90M6-2</td><td>AC-HA017805</td></tr> <tr><td>PL00U-501-90M6-2</td><td>AC-HA017806</td></tr> <tr><td>PL00V-501-90M6-2</td><td>AC-HA017807</td></tr> <tr><td>PL00W-501-90M6-2</td><td>AC-HA017808</td></tr> <tr><td>PL00T-501-90M6-2</td><td>AC-HA017809</td></tr> <tr><td>PL00X-500-90PM8-2</td><td>AC-HA017810</td></tr> <tr><td>PL00Y-500-90PM8-2</td><td>AC-HA017811</td></tr> <tr><td>PL00U-500-90PM8-2</td><td>AC-HA017812</td></tr> <tr><td>PL00V-500-90PM8-2</td><td>AC-HA017813</td></tr> <tr><td>PL00W-500-90PM8-2</td><td>AC-HA017814</td></tr> <tr><td>PL00T-500-90PM8-2</td><td>AC-HA017815</td></tr> <tr><td>PL00X-501-90PM8-2</td><td>AC-HA017816</td></tr> <tr><td>PL00Y-501-90PM8-2</td><td>AC-HA017817</td></tr> <tr><td>PL00U-501-90PM8-2</td><td>AC-HA017818</td></tr> <tr><td>PL00V-501-90PM8-2</td><td>AC-HA017819</td></tr> <tr><td>PL00W-501-90PM8-2</td><td>AC-HA017820</td></tr> <tr><td>PL00T-501-90PM8-2</td><td>AC-HA017821</td></tr> </tbody> </table>		型号 Model	AC P/N	PL00X-500-90M6-2	AC-HA017798	PL00Y-500-90M6-2	AC-HA017799	PL00U-500-90M6-2	AC-HA017800	PL00V-500-90M6-2	AC-HA017801	PL00W-500-90M6-2	AC-HA017802	PL00T-500-90M6-2	AC-HA017803	PL00X-501-90M6-2	AC-HA017804	PL00Y-501-90M6-2	AC-HA017805	PL00U-501-90M6-2	AC-HA017806	PL00V-501-90M6-2	AC-HA017807	PL00W-501-90M6-2	AC-HA017808	PL00T-501-90M6-2	AC-HA017809	PL00X-500-90PM8-2	AC-HA017810	PL00Y-500-90PM8-2	AC-HA017811	PL00U-500-90PM8-2	AC-HA017812	PL00V-500-90PM8-2	AC-HA017813	PL00W-500-90PM8-2	AC-HA017814	PL00T-500-90PM8-2	AC-HA017815	PL00X-501-90PM8-2	AC-HA017816	PL00Y-501-90PM8-2	AC-HA017817	PL00U-501-90PM8-2	AC-HA017818	PL00V-501-90PM8-2	AC-HA017819	PL00W-501-90PM8-2	AC-HA017820	PL00T-501-90PM8-2	AC-HA017821	<table border="1" style="width:100%; border-collapse: collapse;"> <thead> <tr> <th colspan="6">REVISIONS</th> </tr> <tr> <th>REV#</th> <th>ECN#</th> <th>REVISION ACTION</th> <th>REV.BY:</th> <th>APPR.BY:</th> <th>DATE</th> </tr> </thead> <tbody> <tr> <td>A</td> <td>--</td> <td>INITIAL RELEASE</td> <td>Fred</td> <td>JL</td> <td>10/21/2020</td> </tr> <tr> <td>B</td> <td>--</td> <td>Add dust cap, oring and M6 PM8 specifications</td> <td>Star</td> <td>James</td> <td>12/30/2020</td> </tr> </tbody> </table>		REVISIONS						REV#	ECN#	REVISION ACTION	REV.BY:	APPR.BY:	DATE	A	--	INITIAL RELEASE	Fred	JL	10/21/2020	B	--	Add dust cap, oring and M6 PM8 specifications	Star	James	12/30/2020
型号 Model	AC P/N																																																																																																																																																																																
PL00X-500-90M8-2	AC-HA014517																																																																																																																																																																																
PL00Y-500-90M8-2	AC-HA014518																																																																																																																																																																																
PL00U-500-90M8-2	AC-HA014519																																																																																																																																																																																
PL00V-500-90M8-2	AC-HA014520																																																																																																																																																																																
PL00W-500-90M8-2	AC-HA014521																																																																																																																																																																																
PL00T-500-90M8-2	AC-HA014522																																																																																																																																																																																
PL00X-500-90M10-2	AC-HA014523																																																																																																																																																																																
PL00Y-500-90M10-2	AC-HA014524																																																																																																																																																																																
PL00U-500-90M10-2	AC-HA014525																																																																																																																																																																																
PL00V-500-90M10-2	AC-HA014526																																																																																																																																																																																
PL00W-500-90M10-2	AC-HA014527																																																																																																																																																																																
PL00T-500-90M10-2	AC-HA014528																																																																																																																																																																																
PL00X-500-90D8-2	AC-HA014529																																																																																																																																																																																
PL00Y-500-90D8-2	AC-HA014530																																																																																																																																																																																
PL00U-500-90D8-2	AC-HA014531																																																																																																																																																																																
PL00V-500-90D8-2	AC-HA014532																																																																																																																																																																																
PL00W-500-90D8-2	AC-HA014533																																																																																																																																																																																
PL00T-500-90D8-2	AC-HA014534																																																																																																																																																																																
PL00X-500-90D10-2	AC-HA014535																																																																																																																																																																																
PL00Y-500-90D10-2	AC-HA014536																																																																																																																																																																																
PL00U-500-90D10-2	AC-HA014537																																																																																																																																																																																
PL00V-500-90D10-2	AC-HA014538																																																																																																																																																																																
PL00W-500-90D10-2	AC-HA014539																																																																																																																																																																																
PL00T-500-90D10-2	AC-HA014540																																																																																																																																																																																
PL00X-501-90M8-2	AC-HA014541																																																																																																																																																																																
PL00Y-501-90M8-2	AC-HA014542																																																																																																																																																																																
PL00U-501-90M8-2	AC-HA014543																																																																																																																																																																																
PL00V-501-90M8-2	AC-HA014544																																																																																																																																																																																
PL00W-501-90M8-2	AC-HA014545																																																																																																																																																																																
PL00T-501-90M8-2	AC-HA014546																																																																																																																																																																																
PL00X-501-90M10-2	AC-HA014547																																																																																																																																																																																
PL00Y-501-90M10-2	AC-HA014548																																																																																																																																																																																
PL00U-501-90M10-2	AC-HA014549																																																																																																																																																																																
PL00V-501-90M10-2	AC-HA014550																																																																																																																																																																																
PL00W-501-90M10-2	AC-HA014551																																																																																																																																																																																
PL00T-501-90M10-2	AC-HA014552																																																																																																																																																																																
PL00X-501-90D8-2	AC-HA014553																																																																																																																																																																																
PL00Y-501-90D8-2	AC-HA014554																																																																																																																																																																																
PL00U-501-90D8-2	AC-HA014555																																																																																																																																																																																
PL00V-501-90D8-2	AC-HA014556																																																																																																																																																																																
PL00W-501-90D8-2	AC-HA014557																																																																																																																																																																																
PL00T-501-90D8-2	AC-HA014558																																																																																																																																																																																
PL00X-501-90D10-2	AC-HA014559																																																																																																																																																																																
PL00Y-501-90D10-2	AC-HA014560																																																																																																																																																																																
PL00U-501-90D10-2	AC-HA014561																																																																																																																																																																																
PL00V-501-90D10-2	AC-HA014562																																																																																																																																																																																
PL00W-501-90D10-2	AC-HA014563																																																																																																																																																																																
PL00T-501-90D10-2	AC-HA014564																																																																																																																																																																																
型号 Model	AC P/N																																																																																																																																																																																
PL00X-500-90M6-2	AC-HA017798																																																																																																																																																																																
PL00Y-500-90M6-2	AC-HA017799																																																																																																																																																																																
PL00U-500-90M6-2	AC-HA017800																																																																																																																																																																																
PL00V-500-90M6-2	AC-HA017801																																																																																																																																																																																
PL00W-500-90M6-2	AC-HA017802																																																																																																																																																																																
PL00T-500-90M6-2	AC-HA017803																																																																																																																																																																																
PL00X-501-90M6-2	AC-HA017804																																																																																																																																																																																
PL00Y-501-90M6-2	AC-HA017805																																																																																																																																																																																
PL00U-501-90M6-2	AC-HA017806																																																																																																																																																																																
PL00V-501-90M6-2	AC-HA017807																																																																																																																																																																																
PL00W-501-90M6-2	AC-HA017808																																																																																																																																																																																
PL00T-501-90M6-2	AC-HA017809																																																																																																																																																																																
PL00X-500-90PM8-2	AC-HA017810																																																																																																																																																																																
PL00Y-500-90PM8-2	AC-HA017811																																																																																																																																																																																
PL00U-500-90PM8-2	AC-HA017812																																																																																																																																																																																
PL00V-500-90PM8-2	AC-HA017813																																																																																																																																																																																
PL00W-500-90PM8-2	AC-HA017814																																																																																																																																																																																
PL00T-500-90PM8-2	AC-HA017815																																																																																																																																																																																
PL00X-501-90PM8-2	AC-HA017816																																																																																																																																																																																
PL00Y-501-90PM8-2	AC-HA017817																																																																																																																																																																																
PL00U-501-90PM8-2	AC-HA017818																																																																																																																																																																																
PL00V-501-90PM8-2	AC-HA017819																																																																																																																																																																																
PL00W-501-90PM8-2	AC-HA017820																																																																																																																																																																																
PL00T-501-90PM8-2	AC-HA017821																																																																																																																																																																																
REVISIONS																																																																																																																																																																																	
REV#	ECN#	REVISION ACTION	REV.BY:	APPR.BY:	DATE																																																																																																																																																																												
A	--	INITIAL RELEASE	Fred	JL	10/21/2020																																																																																																																																																																												
B	--	Add dust cap, oring and M6 PM8 specifications	Star	James	12/30/2020																																																																																																																																																																												
A		B		C		D																																																																																																																																																																											



	Amphenol Technical Products International Asia.					PART NAME: PL14mm G2 Rcpt Lug 90Degree
	第三角投影 THIRD ANGLE PROJECTION	页面 SHEET	幅面 SIZE	版次 REV.	比例 SCALE	
签名 SIGNATURE	日期 DATE	UNLESS OTHERWISE SPECIFIED 1) All dimensions are in metric(mm). 2) Tolerances are as follows: 1.PL DEC ± 1.00 2.PL DEC ± 0.50 3.PL DEC ± 0.20			DWG NO: PL00X-50X-90XX-2	
制图 DRAWN	审核 CHECKED	批准 APPROVAL	Angles ±1°			CUST PART #
					CUST REV.	