

THIS COPY IS PROVIDED ON A RESTRICTED BASIS AND IS NOT TO BE USED IN ANY WAY DETRIMENTAL TO THE INTERESTS OF PANDUIT CORP.

PANDUIT PART NUMBER	WEIGHT
FKS	.14 LB./EACH [ 65.5 GRAMS/EACH ]

NOTES:

1. SEE CURRENT CATALOG FOR ADDITIONAL PART NUMBER SUFFIXES TO INDICATE PACKAGE QUANTITIES.
2. THE TOOL IS CONSTRUCTED OF CARBON STEEL FRAMES WITH A BLACK FINISH AND RUBBER HAND GRIPS.
3. THE CUTTING EDGE IS SERRATED AND HARDENED.
4. THE TOOL HAS A SPRING THAT ALLOWS THE TOOL TO SPRING OPEN AFTER EACH CUT CYCLE.
5. ALL DIMENSIONS IN BRACKETS ARE METRIC [ mm ]

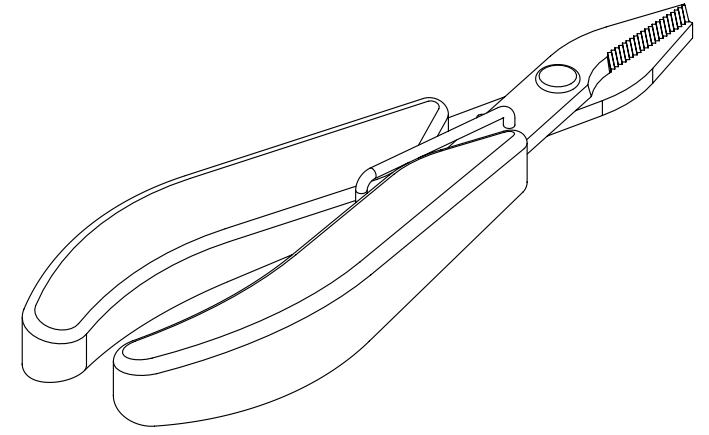
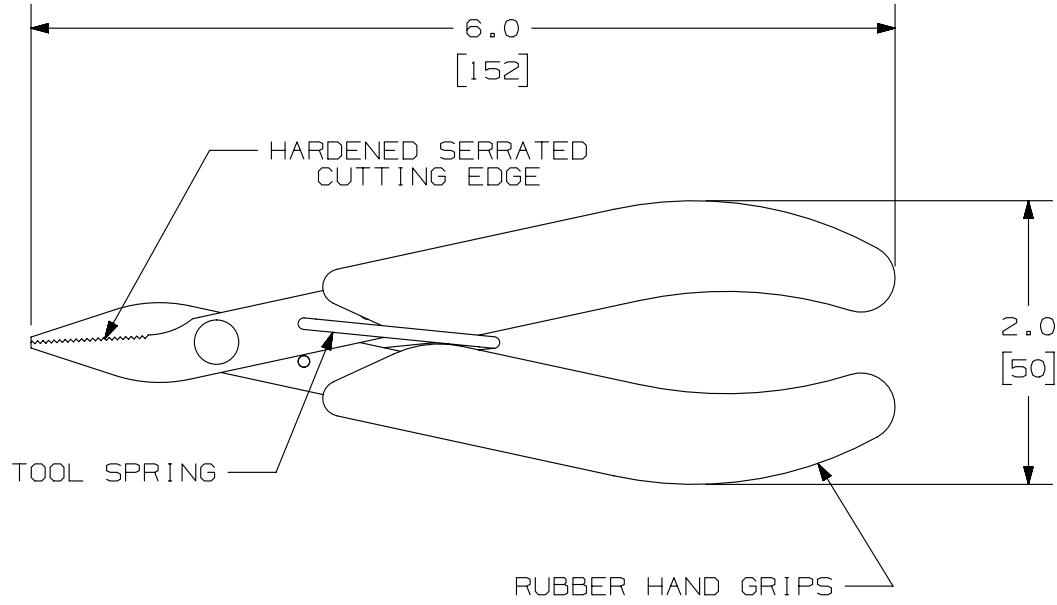

PART NUMBER		FKS							
TITLE									
KEVLAR FIBER CUTTERS									
CUSTOMER DRAWING									
ITEM REVISION NAME		M01190BZ/02							
DATASET FILE NAME		M01190BZ_DC/00B							
UNLESS OTHERWISE SPECIFIED, DIMENSIONAL TOLERANCES ARE: IN [ mm ]				<b>PANDUIT</b>					
.x ±		.xxx ± .010 [ .3 ]							
.xx ± .03 [ .8 ]		ANGLES ±		MATERIAL:					
THIRD ANGLE PROJECTION				DRAWING NUMBER:					
				01190-24					
DRAWN BY	DATE	CHK	SCALE	SIZE					
EFK	07-24-03	RTF I	NONE	A					
REV		DATE		BY	CHK	APR	DESCRIPTION	ECN	SHT 1 OF 1
2	2/6/15	JSP	WJM	RWB	A. REVISED DRAWING TITLE BLOCK.			01190-24	

D10100DA/14