

MATERIAL NUMBER (STD.)	MATERIAL NUMBER (-50)	NO. OF CIRCUITS	A	B
386300602	386301802	2	25.9 (1.02)	11.13 (.438)
386300603	386301803	3	37.1 (1.46)	22.22 (.875)
386300604	386301804	4	48.3 (1.90)	33.35 (1.313)
386300605	386301805	5	59.2 (2.33)	44.45 (1.750)
386300606	386301806	6	70.4 (2.77)	55.57 (2.188)
386300607	386301807	7	81.5 (3.21)	66.67 (2.625)
386300608	386301808	8	92.7 (3.65)	77.80 (3.063)
386300609	386301809	9	103.6 (4.08)	88.90 (3.500)
386300610	386301810	10	114.8 (4.52)	100.03 (3.938)
386300611	386301811	11	125.9 (4.96)	111.13 (4.375)
386300612	386301812	12	137.2 (5.40)	122.25 (4.813)
386300613	386301813	13	148.1 (5.83)	133.35 (5.250)
386300614	386301814	14	159.3 (6.27)	144.45 (5.687)
386300615	386301815	15	170.4 (6.71)	155.58 (6.125)
386300616	386301816	16	181.6 (7.15)	166.70 (6.563)

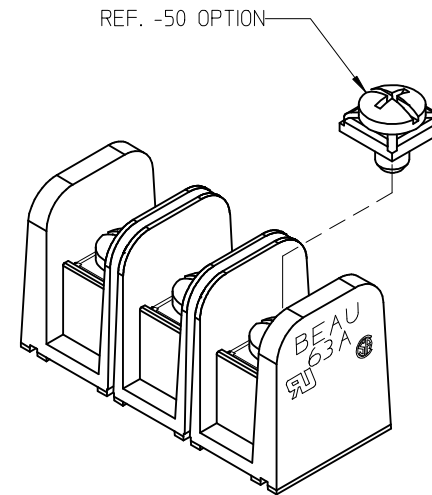
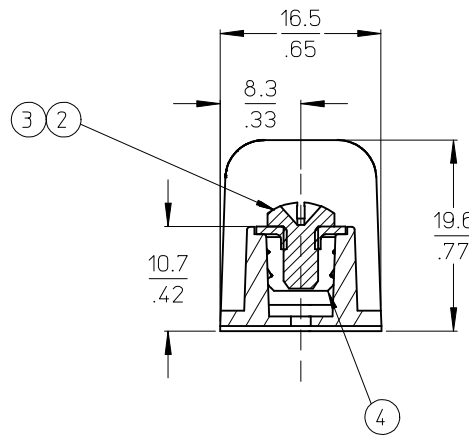
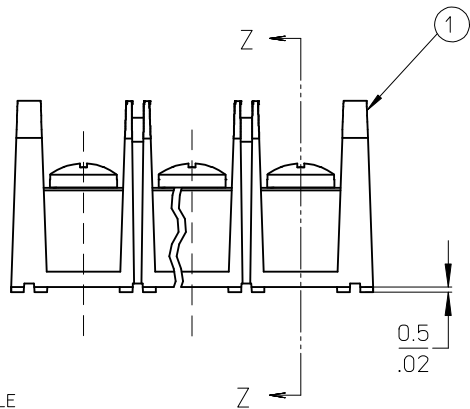

- NOTES:
1. MATERIAL: SEE TABLE
  2. FINISHES: SEE TABLE
  3. PRODUCT SPECIFICATION: NOT REQUIRED
  4. PACKAGING: NOT REQUIRED
  5. MATES WITH: NONE
  6. \*XX\* REFERS TO QTY. OF CIRCUITS
  7. ROHS COMPLIANT (B)

SECTION Z-Z

ITEM	QTY.	DESCRIPTION	MATERIAL	FINISH
4	XX	TERMINAL, CLOSED BACK	BRASS	TIN PLATE
3	XX	SCREW/WSHR #6-32X.250 PAN, PH-SL (-50)	STEEL (B)	ZN, CLEAR CHROMATE
2	XX	SCREW #6-32X.250 BHD, PH-SL (STD.)	STEEL (B)	ZN, CLEAR CHROMATE
1	1	BARRIER TERMINAL STRIP	(B) POLYESTER (PBT)	BLACK

UPDATE MAT. DESCRIP.  
 EC NO: WNA2009-0085  
 DRAWN: ENC INAS 2008/11/25  
 CHKD: CYORK 2008/12/15  
 APPR: JMACNE IL 2008/12/15

QUALITY SYMBOLS  
 ▽=0  
 ▽=0

	GENERAL TOLERANCES (UNLESS SPECIFIED)	
	mm	INCH
4 PLACES	± ---	± ---
3 PLACES	± ---	± .005
2 PLACES	± 0.13	± .01
1 PLACE	± 0.3	± ---
ANGULAR ± 2 °		

DRAFT WHERE APPLICABLE MUST REMAIN WITHIN DIMENSIONS

DIMENSION STYLE  
**MM/IN**

SCALE  
**2:1**

DESIGN UNITS  
**INCH**

THIRD ANGLE PROJECTION

DRAWN BY: R. STONE DATE: 2003/03/25  
 CHECKED BY: R. KEMP DATE: 2003/03/26  
 APPROVED BY: P. WALTZ DATE: 2003/03/28

MATERIAL NO.  
**SEE CHART**

SIZE  
**B**

TITLE  
**11.13/.438" PCB BTS 600V  
 CLOSED BACKS NO MTG ENDS  
 (63A1XX-C)**

**MOLEX INCORPORATED**

DOCUMENT NO.  
**SD-38630-002**

SHEET NO.  
**1 OF 1**

THIS DRAWING CONTAINS INFORMATION THAT IS PROPRIETARY TO MOLEX INCORPORATED AND SHOULD NOT BE USED WITHOUT WRITTEN PERMISSION