

June 1995

8A, 100V - 200V Ultrafast Diodes

Features

- Ultrafast with Soft Recovery <25ns
- Operating Temperature +175°C
- Reverse Voltage Up To 200V
- Avalanche Energy Rated
- Planar Construction

Applications

- Switching Power Supplies
- Power Switching Circuits
- General Purpose

Description

MUR810, MUR815, MUR820, RURP810, RURP815 and RURP820 are ultrafast diodes with soft recovery characteristics ($t_{RR} < 25ns$). They have low forward voltage drop and are silicon nitride passivated ion-implanted epitaxial planar construction.

These devices are intended for use as freewheeling/clamping diodes and rectifiers in a variety of switching power supplies and other power switching applications. Their low stored charge and ultrafast soft recovery minimize ringing and electrical noise in many power switching circuits reducing power loss in the switching transistors.

PACKAGE AVAILABILITY

PART NUMBER	PACKAGE	BRAND
MUR810	TO-220AC	MUR810
MUR815	TO-220AC	MUR815
MUR820	TO-220AC	MUR820
RURP810	TO-220AC	RURP810
RURP815	TO-220AC	RURP815
RURP820	TO-220AC	RURP820

NOTE: When ordering, use the entire part number.

Formerly developmental type TA09223.

Package

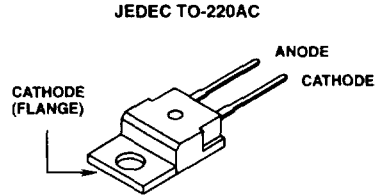

Symbol



Absolute Maximum Ratings $T_C = +25^\circ C$, Unless Otherwise Specified

	MUR810 RURP810	MUR815 RURP815	MUR820 RURP820	UNITS
Peak Repetitive Reverse Voltage V_{RRM}	100	150	200	V
Working Peak Reverse Voltage V_{RWM}	100	150	200	V
DC Blocking Voltage V_R	100	150	200	V
Average Rectified Forward Current $I_{F(AV)}$ ($T_C = +157^\circ C$)	8	8	8	A
Repetitive Peak Surge Current I_{FSM} (Square Wave, 20kHz)	16	16	16	A
Nonrepetitive Peak Surge Current I_{FSM} (Halfwave, 1 Phase, 60Hz)	100	100	100	A
Maximum Power Dissipation P_D	50	50	50	W
Avalanche Energy (See Figures 10 and 11) E_{AVL}	20	20	20	mJ
Operating and Storage Temperature T_{STG}, T_J	-65 to +175	-65 to +175	-65 to +175	$^\circ C$

51
ULTRAFAST
SINGLE DIODES

Specifications MUR810, MUR815, MUR820, RURP810, RURP815, RURP820

Electrical Specifications $T_C = +25^\circ\text{C}$, Unless Otherwise Specified

SYMBOL	TEST CONDITION	MUR810, RURP810			MUR815, RURP815			MUR820, RURP820			UNITS
		MIN	TYP	MAX	MIN	TYP	MAX	MIN	TYP	MAX	
V_F	$I_F = 8\text{A}, T_C = +25^\circ\text{C}$	-	-	0.975	-	-	0.975	-	-	0.975	V
	$I_F = 8\text{A}, T_C = +150^\circ\text{C}$	-	-	0.895	-	-	0.895	-	-	0.895	V
I_R	$V_R = 100\text{V}, T_C = +25^\circ\text{C}$	-	-	100	-	-	-	-	-	-	μA
	$V_R = 150\text{V}, T_C = +25^\circ\text{C}$	-	-	-	-	-	100	-	-	-	μA
	$V_R = 200\text{V}, T_C = +25^\circ\text{C}$	-	-	-	-	-	-	-	-	100	μA
I_R	$V_R = 100\text{V}, T_C = +150^\circ\text{C}$	-	-	500	-	-	-	-	-	-	μA
	$V_R = 150\text{V}, T_C = +150^\circ\text{C}$	-	-	-	-	-	500	-	-	-	μA
	$V_R = 200\text{V}, T_C = +150^\circ\text{C}$	-	-	-	-	-	-	-	-	500	μA
t_{RR}	$I_F = 1\text{A}, dI_F/dt = 200\text{A}/\mu\text{s}$	-	-	25	-	-	25	-	-	25	ns
	$I_F = 8\text{A}, dI_F/dt = 200\text{A}/\mu\text{s}$	-	-	30	-	-	30	-	-	30	ns
t_A	$I_F = 8\text{A}, dI_F/dt = 200\text{A}/\mu\text{s}$	-	13	-	-	13	-	-	13	-	ns
t_B	$I_F = 8\text{A}, dI_F/dt = 200\text{A}/\mu\text{s}$	-	5	-	-	5	-	-	5	-	ns
Q_{RR}	$I_F = 8\text{A}, dI_F/dt = 200\text{A}/\mu\text{s}$	-	25	-	-	25	-	-	25	-	nC
C_J	$V_R = 10\text{V}, I_F = 0\text{A}$	-	60	-	-	60	-	-	60	-	pF
$R_{\theta JC}$		-	-	3	-	-	3	-	-	3	$^\circ\text{C}/\text{W}$

DEFINITIONS

V_F = Instantaneous forward voltage (pw = 300 μs , D = 2%).

I_R = Instantaneous reverse current.

t_{RR} = Reverse recovery time (See Figure 2), summation of $t_A + t_B$.

t_A = Time to reach peak reverse current (See Figure 2).

t_B = Time from peak I_{RM} to projected zero crossing of I_{RM} based on a straight line from peak I_{RM} through 25% of I_{RM} (See Figure 2).

Q_{RR} = Reverse recovery charge.

C_J = Junction Capacitance.

$R_{\theta JC}$ = Thermal resistance junction to case.

E_{AVL} = Controlled Avalanche Energy (See Figures 10 and 11).

pw = pulse width.

D = duty cycle.

V_1 AMPLITUDE CONTROLS I_F
 V_2 AMPLITUDE CONTROLS dI_F/dt
 L_1 = SELF INDUCTANCE OF
 $R_4 + L_{\text{LOOP}}$

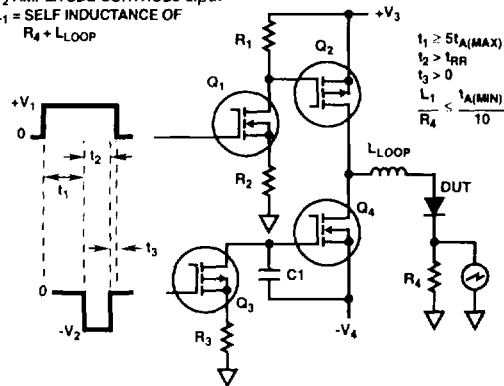

FIGURE 1. t_{RR} TEST CIRCUIT

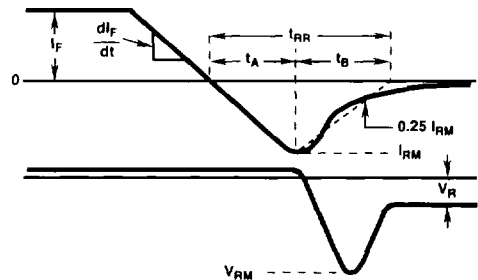

FIGURE 2. t_{RR} WAVEFORMS AND DEFINITIONS

Typical Performance Curves

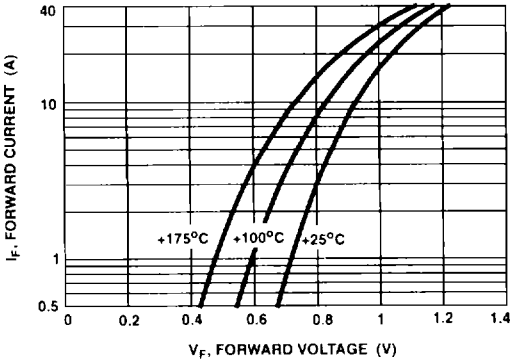

FIGURE 3. TYPICAL FORWARD CURRENT vs FORWARD VOLTAGE DROP

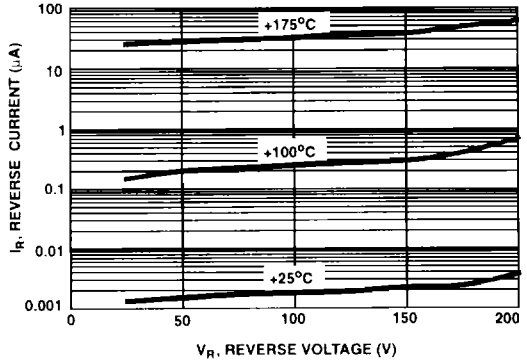

FIGURE 4. TYPICAL REVERSE CURRENT vs REVERSE VOLTAGE

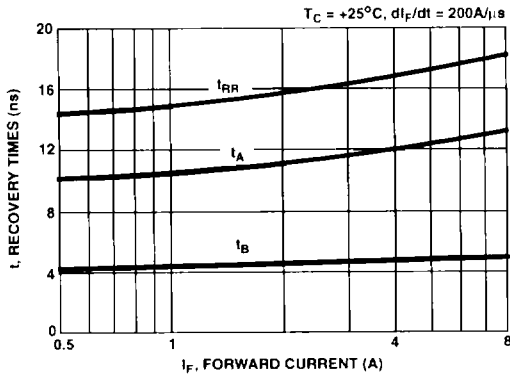

FIGURE 5. TYPICAL t_{RR} , t_A AND t_B CURVES vs FORWARD CURRENT AT +25°C

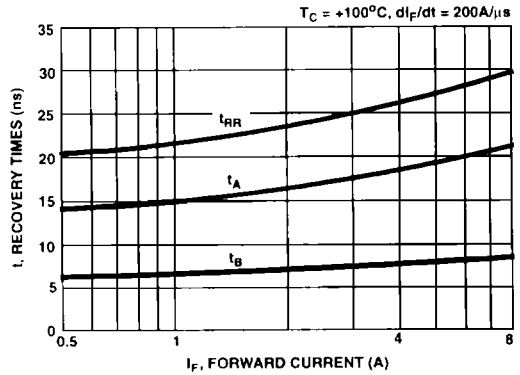

FIGURE 6. TYPICAL t_{RR} , t_A AND t_B CURVES vs FORWARD CURRENT AT +100°C

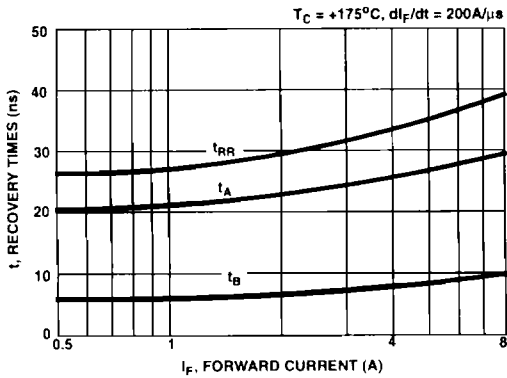

FIGURE 7. TYPICAL t_{RR} , t_A AND t_B CURVES vs FORWARD CURRENT AT +175°C

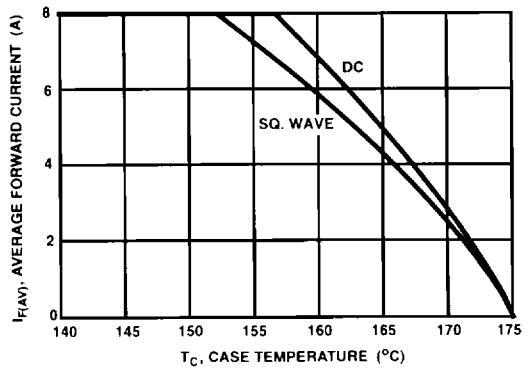

FIGURE 8. CURRENT DERATING CURVE FOR ALL TYPES

5
ULTRAFAST
SINGLE DIODES

Typical Performance Curves (Continued)

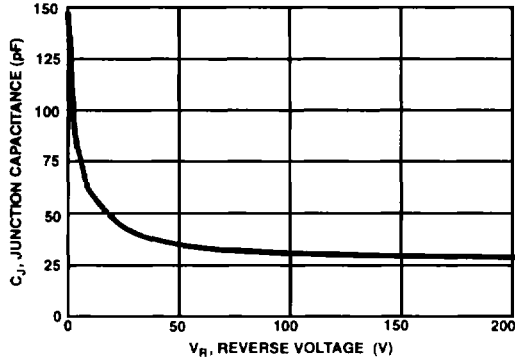

FIGURE 9. TYPICAL JUNCTION CAPACITANCE vs REVERSE VOLTAGE

Test Circuit and Waveforms

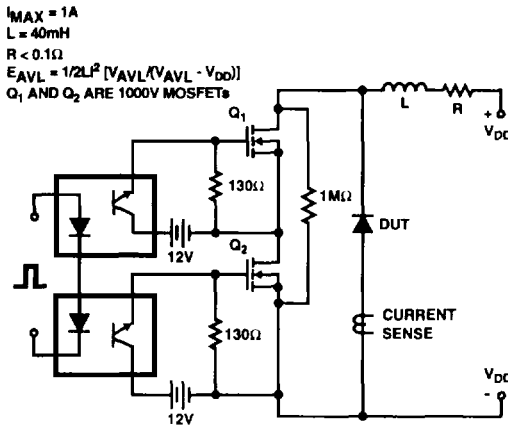

FIGURE 10. AVALANCHE ENERGY TEST CIRCUIT

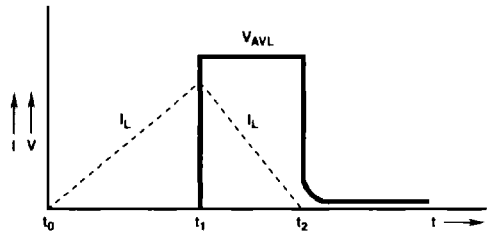

FIGURE 11. AVALANCHE CURRENT AND VOLTAGE WAVEFORMS