

In case of consideration for using Automotive equipment / device which demand high reliability, kindly contact our sales window correspondents.

TO

DESCRIPTION OF REVISIONS	BY	CHKD	DATE	COUNT	DESCRIPTION OF REVISIONS	BY	CHKD	DATE
Δ				Δ				
Δ				Δ				
Δ				Δ				

APPLICABLE STANDARD		OPERATING TEMPERATURE RANGE		STORAGE TEMPERATURE RANGE	
		- 3 5 °C TO 8 5 °C(NOTE1)		- 1 0 °C TO 6 0 °C	
RATING	VOLTAGE	3 0 V A C		APPLICABLE CONNECTOR	DF30*-70DP-0.4V (**)
	CURRENT	0. 3 A			

SPECIFICATIONS			
ITEM	TEST METHOD	REQUIREMENTS	QT / AT
CONSTRUCTION			
GENERAL EXAMINATION	VISUALLY AND BY MEASURING INSTRUMENT.	ACCORDING TO DRAWING.	X / X
MARKING	CONFIRMED VISUALLY.		X / X
ELECTRICAL CHARACTERISTICS			
CONTACT RESISTANCE	1 0 0 mA (DC OR 1000 Hz).	1 0 0 mΩ MAX.	X / -
INSULATION RESISTANCE	1 0 0 V DC.	5 0 MΩ MIN.	X / -
VOLTAGE PROOF	1 0 0 V AC FOR 1 min.	NO FLASHOVER OR BREAKDOWN.	X / -
MECHANICAL CHARACTERISTICS			
MECHANICAL OPERATION	5 0 TIMES INSERTIONS AND EXTRactions.	① CONTACT RESISTANCE: 1 0 0 mΩ MAX. ② NO DAMAGE, CRACK AND LOOSENESS, OF PARTS.	X / -
VIBRATION	FREQUENCY 1 0 TO 5 5 Hz, SINGLE AMPLITUDE 0. 7 5 mm, 1 0 CYCLES OF EACH 3 AXIAL DIRECTION FOR 5 min.	① NO ELECTRICAL DISCONTINUITY OF 1 μs. ② NO DAMAGE, CRACK AND LOOSENESS, OF PARTS.	X / -
SHOCK	4 9 0 m/s ² DURATION OF PULSE 1 1 ms AT 3 TIMES FOR 3 DIRECTIONS.	① NO ELECTRICAL DISCONTINUITY OF 1 μs. ② NO DAMAGE, CRACK AND LOOSENESS, OF PARTS.	X / -
ENVIRONMENTAL CHARACTERISTICS			
DAMP HEAT (STEADY STATE)	EXPOSED AT 4 0 ± 2 °C, 9 0 TO 9 5 %, 9 6 h.	① CONTACT RESISTANCE: 1 0 0 mΩ MAX. ② INSULATION RESISTANCE: 2 5 MΩ MIN. ③ NO DAMAGE, CRACK AND LOOSENESS, OF PARTS.	X / -
RAPID CHANGE OF TEMPERATURE	TEMPERATURE -55 → 5 TO 35 → 85 → 5 TO 35 °C TIME 30 → 10 TO 15 → 30 → 10 TO 15 min UNDER 5 CYCLES.	① CONTACT RESISTANCE: 1 0 0 mΩ MAX. ② INSULATION RESISTANCE: 5 0 MΩ MIN. ③ NO DAMAGE, CRACK AND LOOSENESS, OF PARTS.	X / -
CORROSION SALT MIST	EXPOSED IN 5% SALT WATER SPRAY FOR 48 h (TEST STANDARD:IEC60068)	① CONTACT RESISTANCE: 1 0 0 mΩ MAX. ② NO HEAVY CORROSION.	X / -
SULPHUR DIOXIDE	EXPOSED IN 25 PPM FOR 96h. (TEST STANDARD:IEC60068)	① CONTACT RESISTANCE: 1 0 0 mΩ MAX. ② NO HEAVY CORROSION.	X / -

REMARKS	DRAWN	DESIGNED	CHECKED	APPROVED	RELEASED
NOTE1: INCLUDE THE TEMPERATURE RISING BY CURRENT.	F.MATSUKI	<i>A. Takahashi</i>	<i>T. Saito</i>	<i>T. Saito</i>	
	'05.01.28	'05.01.31	'05.01.31	'05.01.31	

Unless otherwise specified, refer to IEC60512.

Note QT: Qualification Test AT: Assurance Test X: Applicable Test

HRS HIROSE ELECTRIC CO., LTD.	SPECIFICATION SHEET	PART NO.
CODE NO.(OLD) :	DRAWING NO.	DF30FC-70DS-0.4V(81)
CL	ELC4-303467-03	CL684-1115-0-81

FORM No.231-1

In case of consideration for using Automotive equipment / device which demand high reliability, kindly contact our sales window correspondents.

COUNT	DESCRIPTION OF REVISIONS	BY	CHKD	DATE	COUNT	DESCRIPTION OF REVISIONS	BY	CHKD	DATE
4	RE-H-06664	Y.M	T.S	04.12.17					..
									..
									..

■ NOTES WHEN MATING DF30 SERIES CONNECTORS.

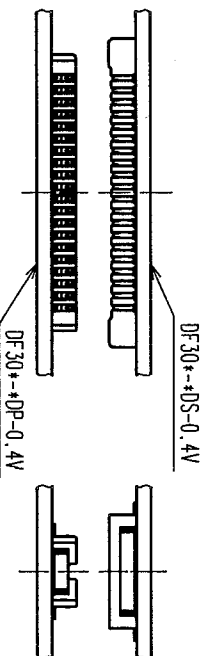

FIGURE - 1

PLEASE LOCATE EACH CONNECTOR IN PARALLEL WHEN YOU PUT THEM IN MATING POSITION.

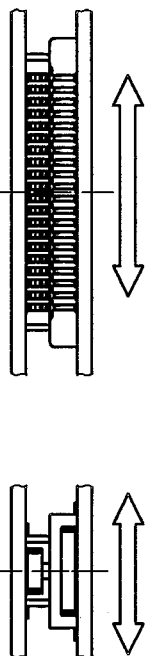

FIGURE - 2

THE INSULATOR WILL BE DAMAGED AND THE CONTACTS WILL BE DEFORMED IF THE CONNECTORS ARE LOCATED INCLINED AND MATED BY EXCESSIVE FORCE.

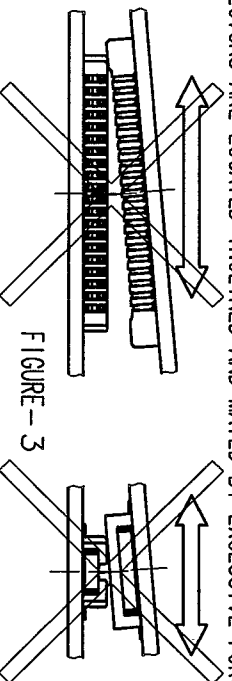

FIGURE - 3

WHEN YOU LOCATE TWO CONNECTORS IN A PROPER POSITION, THEY WILL GO DOWN SLIGHTLY AT A LOWER LEVEL AND YOU WILL FIND THAT THEY GET LOCATED CORRECTLY. PLEASE MATE EACH CONNECTOR IN PARALLEL AFTER YOU CONFIRMED THAT THEY GO DOWN LOWER TO SOME EXTENT.

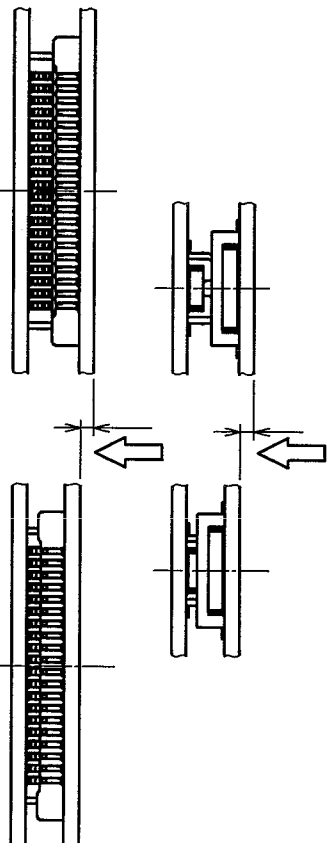

FIGURE - 4

THE MATED CONDITIONS CAN BE RELEASED BY A DROP IMPACT OR THE APPLIED FORCE CAUSED BY FCC-HANDLING. FIX THE CONNECTORS BY APPLYING PRESSURE IN THE MATING DIRECTION WITH THE DEVICE OR A BUFFER MATERIAL.

CODE NO. (OLD)

DRAWN

Y.MICHIDA

DESIGNED

A.TAKAHASHI

CHECKED

T.SAKATA

APPROVED

T.OMA

RELEASED

NOTES WHEN MATING

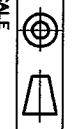

DRAWING NO.

EDSC4-830174

PART NO.

DF30 Series

SCALE

FREE : 1

UNITS

MM

CODE NO.

CL684

1/3

TO

1

2

3

4

In case of consideration for using Automotive equipment / device which demand high reliability, kindly contact our sales window correspondents.

COUNT	DESCRIPTION OF REVISIONS	BY	CHKD	DATE	COUNT	DESCRIPTION OF REVISIONS	BY	CHKD	DATE

■ NOTES WHEN EXTRACTING

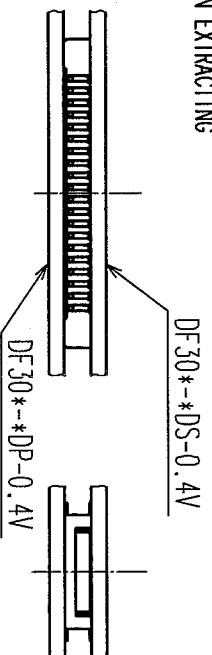

FIGURE-5

WHEN YOU EXTRACT CONNECTORS, PLEASE EXTRACT IN PARALLEL.

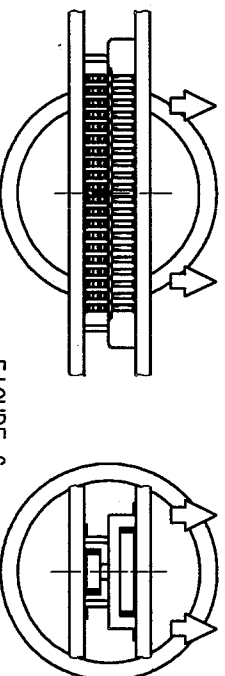

FIGURE-6

△ IF YOU'RE UNABLE TO EXTRACT IN PARALLEL DUE TO SET STRUCTURE OR SPACE, PLEASE EXTRACT AS FIGURE-7 (IN LONGER DIMENSION). PLEASE BE CAREFUL NOT TO DAMAGE CONTACTS AT SIDES, WHERE STRESS IS LIKELY TO GATHER WHEN CONNECTORS ARE MOUNTED ON SOFT FPC.

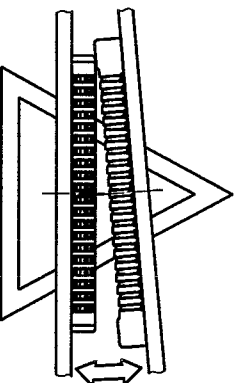

FIGURE-7

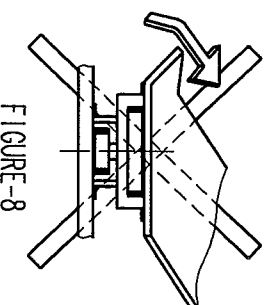

FIGURE-8

△ ESPECIALLY, PLEASE DO NOT EXTRACT FROM THE CORNER AS FIGURE-8. IT GIVES CRITICAL STRESS TO THE CONTACTS ON THE CROSS CORNER.

△ PLEASE DO NOT EXTRACT AS FIGURE-9. THE STRESS CONCENTRATES ON ONE ROW, AND MIGHT DAMAGE CONNECTORS TO MALFUNCTION.

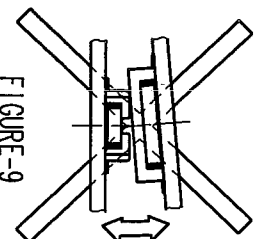
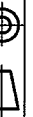

FIGURE-9

CODE NO. (OLD)

NOTES WHEN EXTRACTING	DRAWN	DESIGNED	CHECKED	APPROVED	RELEASED
	Y. MICHIDA 04.12.16	A. TAKAHASHI 04.12.16	T. SAKATA 04.12.16	T. OMA 04.12.16	



SCALE
FREE : 1
UNITS
mm

DRAWING NO.

EDSC4-830174

PART NO.

DF30 Series

CODE NO.

CL684

HRS

HIROSE ELECTRIC CO., LTD.

TO

1

2

3

4



In case of consideration for using Automotive equipment / device which demand high reliability, kindly contact our sales window correspondents.

1	2	3	4
COUNT	DESCRIPTION OF REVISIONS	BY CHKD	DATE

△ WHEN FPC IS SOFT, STRESS IS CONCENTRATED ON THE CONTACTS AT CORNERS. PLEASE PAY ATTENTION TO THIS POINT AND DO NOT UNMATE CONNECTORS FROM CORNERS AS FIGURE-10. THIS GIVES SERIOUS DAMAGE ON CONTACTS, AND OCCURS SOLDER PEEL-OFF OR CONTACT COME-OFF.

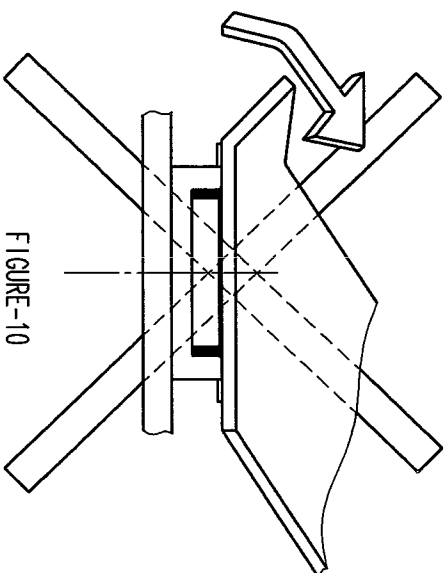

FIGURE-10

IF YOU MOUNT PLUG CONNECTOR ON FPC, CONTACTS MIGHT COME OFF FROM HOUSING MOLD.

CONTACT MIGHT COME OFF FROM HOUSING MOLD.

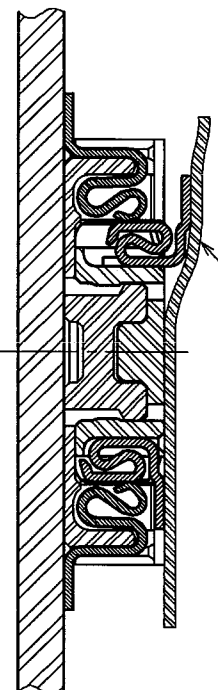

FIGURE-11

IN CASE YOU MOUNT RECEPTACLE CONNECTOR ON FPC, THERE IS NO RISK OF CONTACT COME-OFF. HIROSE RECOMMEND THAT RECEPTACLE IS MOUNTED ON FPC.

IN ORDER TO AVOID THIS RISK, IT IS RECOMMENDED THAT YOU MOUNT RECEPTACLE CONNECTOR ON FPC.

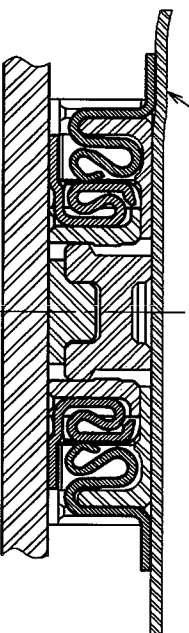

FIGURE-12

CODE NO. (OLD)		DRAWN				DESIGNED		CHECKED		APPROVED		RELEASED	
NOTES WHEN EXTRACTING (SUPPLEMENTARY DATA)		Y.MICHIDA		A.TAKAHASHI		T.SAKATA		T.OMA					
		04.12.16		04.12.16		04.12.16		04.12.16					
SCALE FREE : 1		DRAWING NO. EDSC4-830174		PART NO. DF30 Series		CODE NO. CL684							
UNITS mm		HIROSE ELECTRIC CO.,LTD.											

TO

1

2

3

4

In case of consideration for using Automotive equipment / device which demand high reliability, kindly contact our sales window correspondents.

TO

COUNT	DESCRIPTION OF REVISIONS	BY	CHKD	DATE	COUNT	DESCRIPTION OF REVISIONS	BY	CHKD	DATE
△					△				..
△					△				..
△					△				..

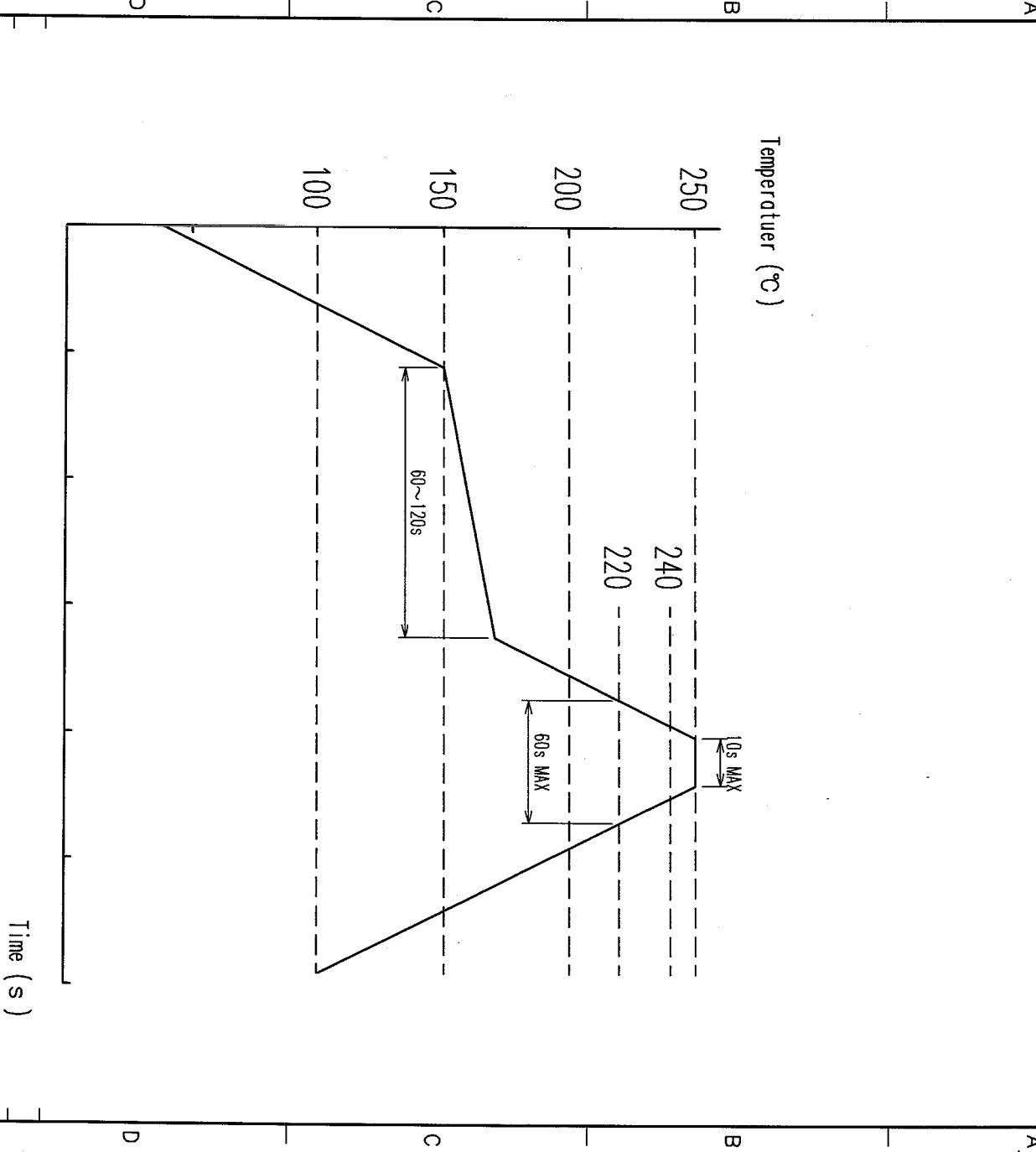

NOTE 1. REFLOW SYSTEM : IR REFLOW (AIR OR N₂ GAS)
 2. PERFORMING REFLOW : TWICE MAX

NO. MATERIAL	FINISH, REMARKS	NO. MATERIAL	FINISH, REMARKS
CODE NO. (OLD)			
RECOMMENDED TEMPERATURE PROFILE		DRAWN	DESIGNED
		T. NISHI 03.08.19	W. Takahashi 03.08.19
		CHECKED	APPROVED
		<i>[Signature]</i> 03.08.20	T. Ono 03.08.20
		RELEASED	
SCALE FREE	DRAWING NO. EDC4-830116	PART NO. DF30-*DS/DP-0.4V	CODE NO. CL684
UNITS mm	HRS HIROSE ELECTRIC CO., LTD.		

