

FEATURES

Single-ended and differential input capability
**Small size board allows easy integration into custom
space-constrained applications (6.6 mm × 6.6 mm)**

GENERAL DESCRIPTION

The SSM2317 is a fully integrated, single-chip, mono Class-D audio amplifier. It is designed to maximize performance for mobile phone applications. The application circuit requires a minimum of external components and operates from a single 2.5 V to 5.5 V supply. It is capable of delivering 1.4 W of continuous output power with less than 1% THD + N, driving an 8 Ω load from a single 5.0 V supply.

The SSM2317 is equipped with a differential mode input port and a high efficiency, full H-bridge at the output that enables direct coupling of the audio power signal to the loudspeaker. The differential mode input stage allows for cancelling of common-mode noise.

The part also features a high efficiency, low noise output modulation scheme that does not require external LC output filters when attached to an inductive load. It operates with 85% efficiency at 1.4 W into 8 Ω from a 5.0 V supply and has a signal-to-noise ratio (SNR) that is better than 93 dB.

Spread-spectrum modulation is used to provide lower EMI-radiated emissions. The modulation provides high efficiency even at low output power. Filterless operation also helps to decrease distortion due to the nonlinearities of output LC filters.

This data sheet describes how to configure and use the SSM2317 mini evaluation board to test the SSM2317. It is recommended that this data sheet be read in conjunction with the [SSM2317](#) data sheet, which provides more detailed information about the specifications, internal block diagrams, and application guidance for the amplifier IC.

EVALUATION BOARD DESCRIPTION

The SSM2317 mini evaluation board is a small form factor board (6.6 mm × 6.6 mm) with a pair of differential audio input terminals (IN+ and IN-), a pair of audio signal output terminals (OUT+ and OUT-), a ground terminal, and a VDD terminal. It is designed for easy integration into the SSM2317 application board.

The SSM2317 mini evaluation board carries a complete application circuit for driving a loudspeaker. Figure 1 shows the top view of the evaluation board, and Figure 2 shows the bottom view.



Figure 1. SSM2317 Evaluation Board Top View

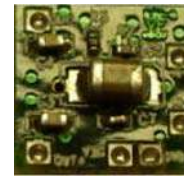

Figure 2. SSM2317 Evaluation Board Bottom View

Rev. 0

Evaluation boards are only intended for device evaluation and not for production purposes. Evaluation boards are supplied "as is" and without warranties of any kind, express, implied, or statutory including, but not limited to, any implied warranty of merchantability or fitness for a particular purpose. No license is granted by implication or otherwise under any patents or other intellectual property by application or use of evaluation boards. Information furnished by Analog Devices is believed to be accurate and reliable. However, no responsibility is assumed by Analog Devices for its use, nor for any infringements of patents or other rights of third parties that may result from its use. Analog Devices reserves the right to change devices or specifications at any time without notice. Trademarks and registered trademarks are the property of their respective owners. Evaluation boards are not authorized to be used in life support devices or systems.

EVAL-SSM2317-MINI

TABLE OF CONTENTS

Features	1	PCB Layout Guidelines.....	4
General Description	1	Getting Started.....	4
Evaluation Board Description.....	1	Evaluation Board Schematic and Artwork.....	5
Revision History	2	Ordering Information	8
Evaluation Board Hardware.....	3	Bill of Materials.....	8
Input and Output Configuration.....	3	Ordering Guide	8
Component Selection.....	3	ESD Caution.....	8

REVISION HISTORY

5/09—Revision 0: Initial Version

EVALUATION BOARD HARDWARE

INPUT AND OUTPUT CONFIGURATION

On the bottom side of the board, there are two pad terminals, IN+ and IN–, as shown in Figure 5. They are used to feed the audio signal into the board. The two output terminals, marked OUT+ and OUT– in Figure 5, drive a loudspeaker whose impedance should not be less than 4 Ω.

Although the SSM2317 does not require external LC output filters to operate because it has a low noise modulation scheme, if the speaker length is >10 cm, it is recommended to put a ferrite bead (L1 and L2) near each output pin of the SSM2317 to reduce electromagnetic interference (EMI), as shown in the schematic in Figure 3. For optimal performance, as specified in the SSM2317 data sheet (in particular, for THD and SNR), remove the entire EMI filter, short across the ferrite bead terminals, and open the capacitor terminals.

COMPONENT SELECTION

Selecting the right components is the key to achieving the performance required at the budgeted cost.

ALC Threshold Setting Resistor—R3

The maximum output amplitude threshold (V_{TH}) during the limiting operation can be changed from 90% to 45% of V_{DD} by inserting an external resistor, R_{TH} , between the VTH pin and GND. Shorting the VTH pin to GND sets V_{TH} to 90% of V_{DD} . Leaving the VTH pin unconnected sets V_{TH} to 45% of V_{DD} . The relation of R_{TH} to V_{TH} is shown by the following equation:

$$V_{TH} = 0.9 \times \frac{50 \text{ k}\Omega + R_{TH}}{50 \text{ k}\Omega + 2 \times R_{TH}} \times V_{DD}$$

Maximum output power is derived from V_{TH} by the following equation:

$$P_{OUT} = \frac{\left(\frac{V_{TH}}{\sqrt{2}}\right)^2}{R_{SP}}$$

where R_{SP} is the speaker impedance.

Input Coupling Capacitor Selection—C1 and C2

The input coupling capacitors, C1 and C2, should be large enough to couple the low frequency components in the incoming signal but small enough to filter out unnecessary lower frequency signals. For music signals, the cutoff frequency is, typically, between 20 Hz and 30 Hz.

The cutoff frequency is calculated by

$$C = 1/(2\pi R f_c),$$

where:

$R = 10 \text{ k}\Omega + R_{ext}$ (the external resistor used to fine-tune the desired gain; on the schematics (see Figure 3), this is the 0 Ω resistor at the input pins).

f_c is the cutoff frequency.

Output Ferrite Beads—L1 and L2

The L1 and L2 output beads are necessary components for filtering out the EMI caused at the switching output nodes when the length of the speaker wire is greater than 10 cm. The penalty for using ferrite beads for EMI filtering is slightly worse noise and distortion performance at the system level due to the non-linearity of the beads. Make sure that these beads have enough current conducting capability while providing sufficient EMI attenuation.

The current rating needed for an 8 Ω load is about 420 mA. Impedance for the beads at 100 MHz must be 220 Ω. In addition, the lower the dc resistance (DCR) of the beads, the better for minimizing their power consumption. Table 1 shows the recommended beads.

Output Shunting Capacitors—C3 and C4

Two capacitors, C3 and C4, work with the L1 and L2 ferrite beads. Use small size (0603 or 0402), multilayer ceramic capacitors made from X7R or COG (NPO) materials.

Note that the capacitors can be used in pairs: a capacitor with small capacitance (up to 100 pF) plus a capacitor with bigger capacitance (1 nF). This configuration provides better EMI reduction for the whole frequency spectrum. For BOM cost reduction and capable performance, a single capacitor of approximately 470 pF can be used.

Table 1. Recommended Beads

Part No.	Manufacturer	Z (Ω)	I _{MAX} (mA)	DCR (Ω)	Size (mm)
BLM18PG121SN1D	Murata	120	2000	0.05	1.6 × 0.8 × 0.8
MPZ1608S101A	TDK	100	3000	0.03	1.6 × 0.8 × 0.8
MPZ1608S221A	TDK	220	2000	0.05	1.6 × 0.8 × 0.8
BLM18EG221SN1D	Murata	220	2000	0.05	1.6 × 0.8 × 0.8

EVAL-SSM2317-MINI

PCB LAYOUT GUIDELINES

To keep the EMI under the allowable limit and ensure that the amplifier chip operates under the temperature limit, PCB layout is critical in application design. The SSM2317 works well only if the following techniques are implemented in the PCB design to keep EMI and the amplifier temperature low.

Layer Stacks and Grounding

Use a 4-layer structure in the stack-up for the evaluation board, as follows:

- Top layer—component layer with power and output copper land and ground copper pouring.
- Second layer—dedicated ground plane.
- Third layer—dedicated power plane.
- Bottom layer—bottom layer with ground copper pouring.

Component Placement and Clearance

Place all related components except decoupling capacitors on the same side as the SSM2317 to avoid vias and as close as possible to the chip (see Figure 4).

Place the decoupling capacitors, C5 and C7, on the bottom side as close as possible to the VDD and GND pins (see Figure 5).

Place the C3 and C4 capacitors and the R1 pull-up resistor on the bottom layer (see Figure 5).

Traces and Solder Resist

All traces between adjacent pads must be covered with solder resist. Traces should come symmetrically off the pads.

Use 5 mils traces at the SSM2317 pads to prevent the solder from escaping.

Top Layer Copper Land and Ground Pouring

The output peak current of this amplifier is more than 1 A; therefore, PCB traces should be wide (>2 mm) to handle high current. For the best performance, use symmetrical copper lands as large as space allows, instead of traces for output pins (see Figure 3).

Pour ground copper on the top side and use many vias to connect the top layer ground copper to the dedicated ground plane. The copper pouring land on the top layer serves as both the EMI shielding ground plane and the heat sink for the SSM2317.

Power Land

Connect Pin B2 directly to Pin A2 by a 5 mil trace and make a copper land for the power near A2. If space allows, use four 12/24 mil vias to connect the top layer power land to the dedicated power plane (Layer 3).

GETTING STARTED

To ensure proper operation, carefully follow Step 1 through Step 3.

1. Connect the load to the audio output terminals, OUT+ and OUT-.
2. Connect the audio input to the audio input terminals, IN+ and IN-.
3. Connect the power supply to VDD and GND.

EVALUATION BOARD SCHEMATIC AND ARTWORK

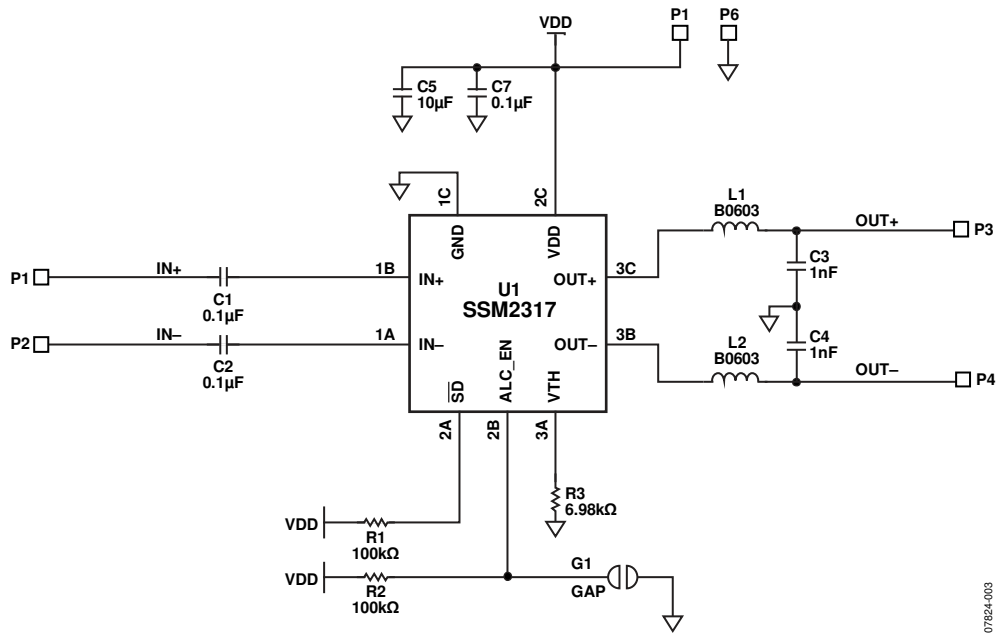

Figure 3. Schematic of the SSM2317-MINI Evaluation Board

07824-003

EVAL-SSM2317-MINI

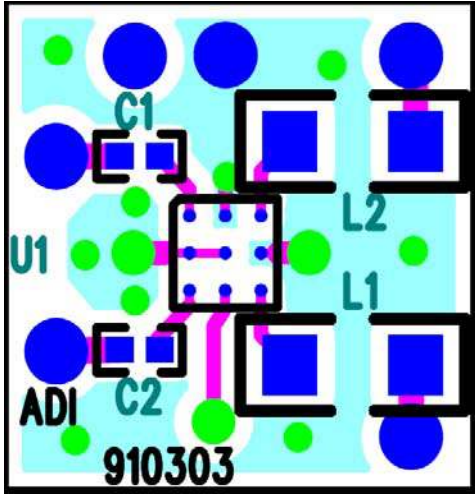

Figure 4. Top Layer with Top Silkscreen

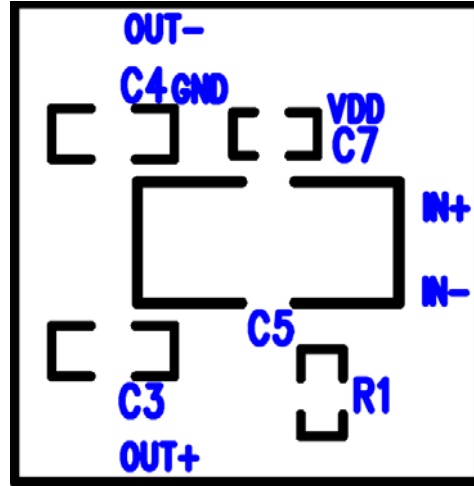

Figure 7. Top Layer

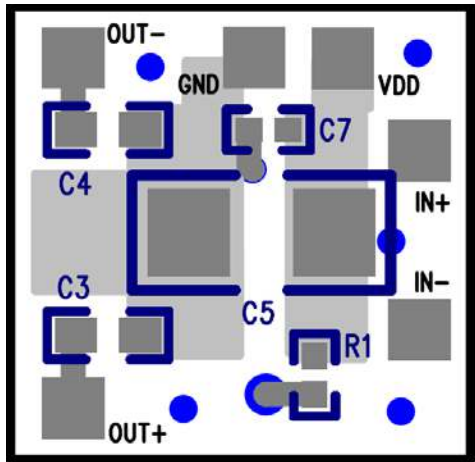

Figure 5. Bottom Layer with Bottom Silkscreen (Mirror Image)

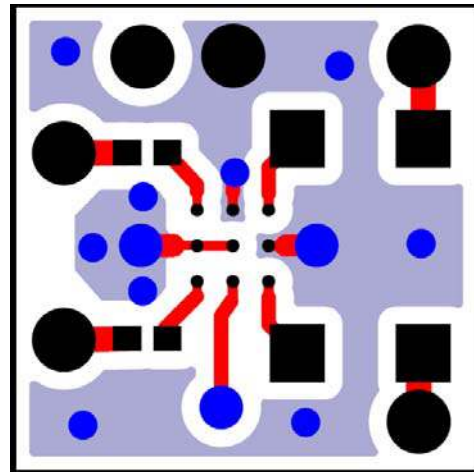

Figure 8. Top Layer

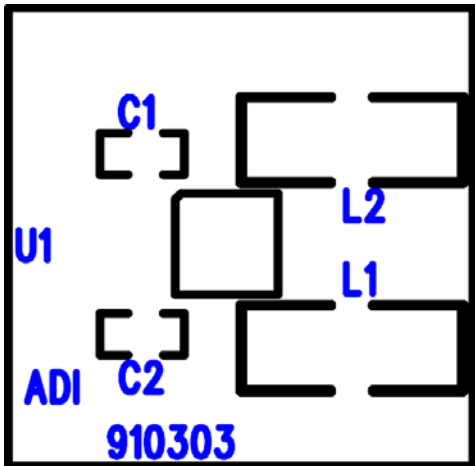

Figure 6. Top Silkscreen

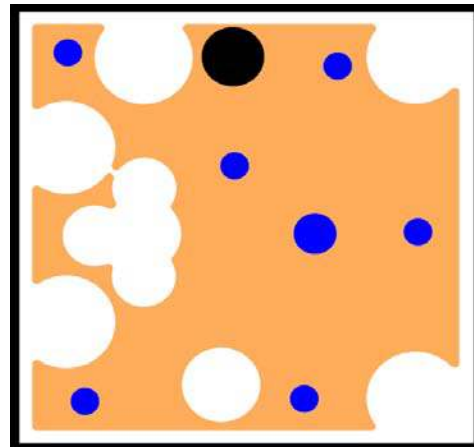
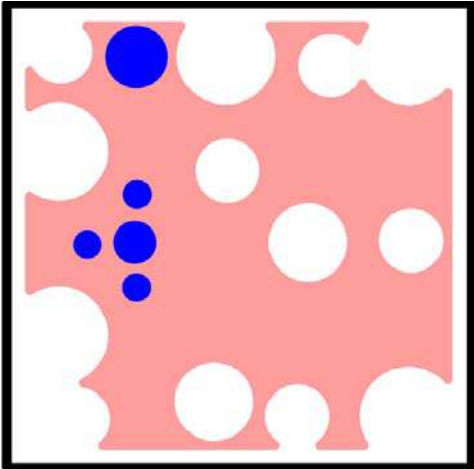
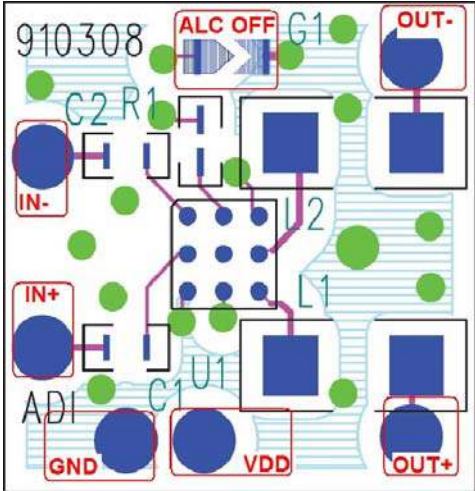

Figure 9. Layer 2 (Ground Plane)



07824-010

Figure 10. Layer 3 (Power Plane)



07824-012

Figure 12. All Layer Silkscreen

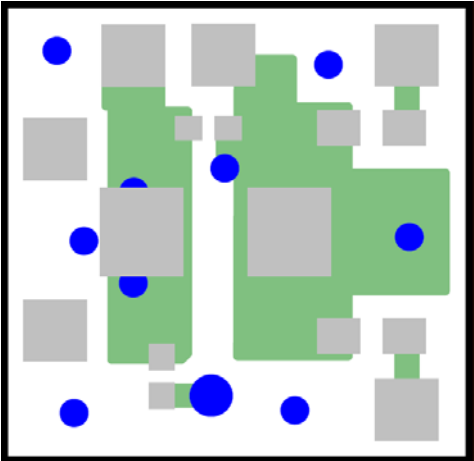

07824-011

Figure 11. Bottom Layer

EVAL-SSM2317-MINI

ORDERING INFORMATION

BILL OF MATERIALS

Table 2.

Qty	Reference Designator	Description	Supplier/Part No.
3	C1, C2, C7	Ceramic capacitor, 0.1 μ F, 6.3 V	Murata, GRM033R60J104KE19D
2	C3, C4	Ceramic capacitor, 1 nF, 10%, 5 V	Kemet, C0603C102J5GACTU
1	C5	Ceramic capacitor, 10 μ F, 10 V	Murata, GRM31MF51A106ZA01L
1	G1	GAP	N/A
2	L1,L2	Ferrite chip, B0603, 220 Ω , 2 A	TDK, MPZ1608S221A
6	P1, P2, P3, P4, P5, P6	PAD1	N/A
2	R1, R2	Resistor, 100 k Ω	Panasonic, ERJ-1GEF1003C
1	R3	Resistor, 6.98 k Ω	Panasonic, ERJ-1GEF6981C
1	U1	SSM2317	Analog Devices, SSM2317

ORDERING GUIDE

Model	Description
SSM2317-MINI-EVALZ ¹	Evaluation Board

¹ Z = RoHS Compliant Part.

ESD CAUTION



ESD (electrostatic discharge) sensitive device.

Charged devices and circuit boards can discharge without detection. Although this product features patented or proprietary protection circuitry, damage may occur on devices subjected to high energy ESD. Therefore, proper ESD precautions should be taken to avoid performance degradation or loss of functionality.