

PART NUMBER	REV	FIRST USED	POWER UNIT	FEED TYPE	DESCRIPTION
1855604-1	B	122500-1	LEADMAKER	AIR FEED	CUTS CARRIER
1855604-2	B	565435-5	BENCH MODEL K	AIR FEED	CUTS CARRIER
1855604-3	B	354500-1	BENCH MODEL G	AIR FEED	CUTS CARRIER
7-1855604-7	A	-	-	-	SPARE PARTS

TEC PN		MFG PN		TEC TERMINAL - TEC CRIMP SPECS		REF SETTING*	
2113158	4	BOSCH		CRIMP HEIGHT	WIRE SIZE		
-	-	192849824	3/4	A	.065±.002 [1.70±0.05mm]	2.5mm <sup>2</sup>	A-5
-	-	-	-	B	.061±.002 [1.55±0.05mm]	2.0mm <sup>2</sup>	B-4
-	-	-	-	C	.055±.002 [1.40±0.05mm]	1.5mm <sup>2</sup>	C-6
-	-	-	-	D	-	-	-
		CRIMP	SIZE	TYPE	RANGE		
-	-	WIRE	.095	F	1.5mm <sup>2</sup> - 2.5mm <sup>2</sup>		
-	-	INSUL	.130	O	2.4mm <sup>2</sup> - 3.0mm <sup>2</sup>		
WIRE STRIP LENGTH		TERM APPL SPEC		FEED	APPL INSTRUCTIONS	SET UP GAGE	
.211-.226		-		1.160	408-8039	458638-1	

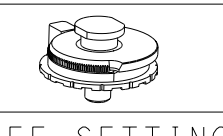

- △ RECOMMENDED SPARE PARTS.
- △ GREASE LIGHTLY.
- △ GUARD MUST BE IN PLACE WHEN OPERATING APPLICATOR IN A BENCH MACHINE.
- △ TERMINAL LUBRICANT IS RECOMMENDED.

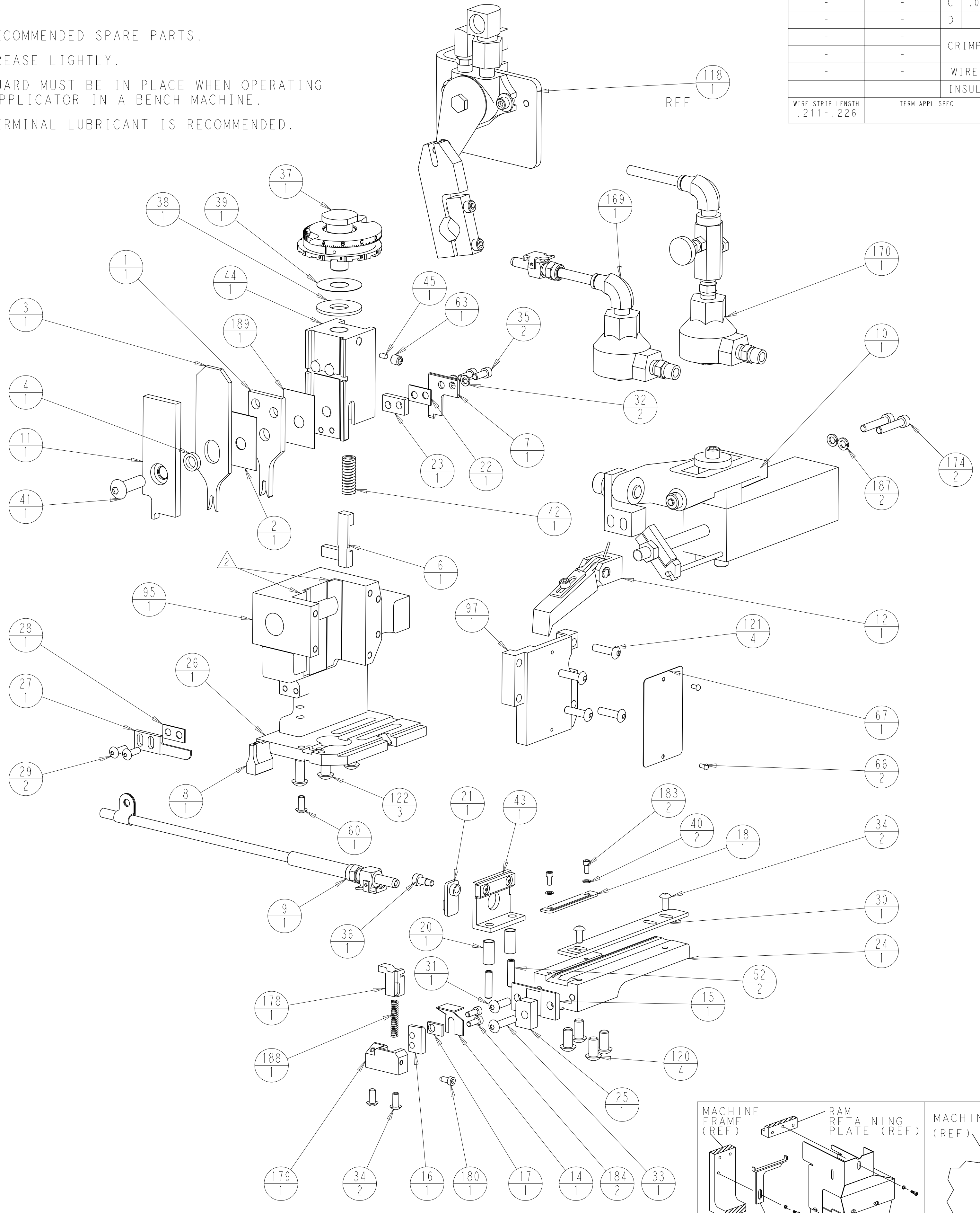

SCALE 3:5

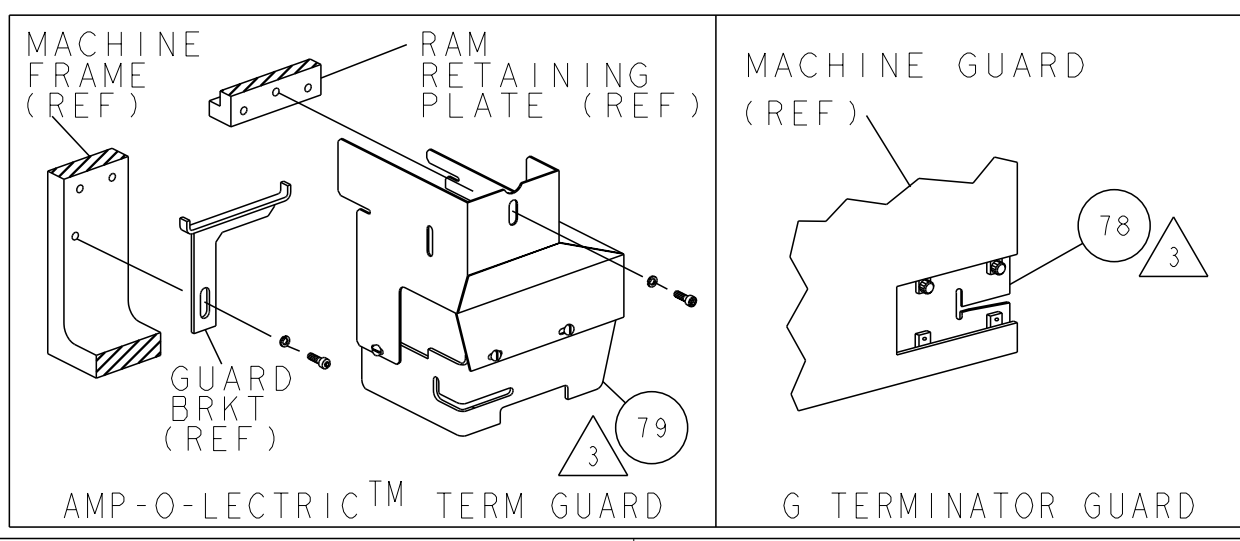

REF	REF	REF	REF	REF	DESCRIPTION	ITEM NO	
-	REF	REF	-	..	679532-1	INSERT, GUARD	78
-	1	1	1	-	217238-1	GENERAL INSTRUCTION PKG	72
-	1	1	1	-	4088039	EF APPL INST 408-8039	71
-	1	1	1	-	461264-5	PLATE, IDENTIFICATION	67
-	2	2	2	-	21017-2	SCREW, DRIVE	66
-	1	1	1	-	21009-2	SCR, SET, SELF LOCKING 1/4-20 X .250	63
-	3	3	1	-	22733-8	SCR, BHSC, SELF-LOCKING, 8-32 X .375	60
-	2	2	2	-	5-21006-6	SCR, SET, CUP POINT 10-32 X .750	52
-	1	1	1	-	690191-1	PLUG, NYLON	45
-	1	1	1	-	1338281-7	RAM	44
-	1	1	1	-	679754-1	STOCK DRAG ASSEMBLY	43
-	1	1	1	-	23846-1	SPRING, DIE	42
-	1	1	1	-	7-21002-9	SCR, BTN SKT HD CAP 5/16-24 X 1.00	41
-	2	2	2	-	21024-2	WASHER, SPRG LOCK, REG NO 4	40
-	1	1	1	-	690125-1	SHIM SUB-ASSY	39
-	1	1	1	-	469367-6	SHIM	38
-	1	1	1	-	879103-2	FINE ADJUST HEAD SUBASSY	37
-	1	1	1	-	21989-8	SCR, SKT HD SHLDR 3/16 DIA X .250	36
-	2	2	2	-	9-21000-9	SCR, SKT HD CAP 8-32 X .438	35
-	2	2	4	-	2-21002-1	SCR, BTN SKT HD CAP 8-32 X .375	34
-	1	1	1	-	3-21002-0	SCR, BTN SKT HD CAP 10-32 X .875	33
-	3	3	2	-	21024-4	WASHER, SPRG LOCK, REG NO 8	32
-	1	1	1	-	2-21002-8	SCR, BTN SKT HD CAP 10-32 X .625	31
-	1	1	1	-	454204-3	GUIDE, LOWER STRIP	30
-	2	2	2	-	2-21002-2	SCR, BTN SKT HD CAP 8-32 X .500	29
-	1	1	1	-	1-690451-3	SPACER, STRIPPER	28
-	1	1	1	-	240639-4	STRIPPER (MACHINING)	27
-	1	1	1	-	1320117-1	PLATE, BASE	26
-	1	1	1	-	3-690481-5	SPACER, HOLD DOWN	25
-	1	1	1	-	2161152-1	PLATE, STRIP GUIDE	24
-	1	1	1	-	5-240641-0	SPACER	23
-	1	1	1	-	1-240641-9	SPACER	22
-	1	1	1	-	356835-1	LEVER, DRAG RELEASE	21
-	2	2	2	-	22281-9	SPRING, COMPRESSION	20
-	1	1	1	-	690438-1	FRONT STRIP GUIDE	18
-	1	1	1	-	4-240645-8	SPACER, SHEAR PLATE	17
△	1	1	1	1	2161155-1	PLATE, SHEAR	16
△	1	1	1	1	240833-1	PLATE, REAR SHEAR	15
-	1	1	1	1	1633998-1	GUARD, CHIP MINI APPLICATOR	14
-	1	1	1	1	460680-1	FEED FINGER ASSEMBLY	12
-	1	1	1	1	1-455889-4	DEPRESSOR, SHEAR	11
-	1	1	1	1	460277-2	AIR FEED ASSY	10
-	1	1	1	1	318848-1	AIR BLAST ASSEMBLY	9
△	1	1	1	1	1-853224-2	ANVIL, COMBINATION	8
△	1	1	1	1	2161156-1	BLADE, SLUG, RIGHT HAND	7
-	1	1	1	1	9-455892-0	HOLD DOWN, TERMINAL	6
-	1	1	1	1	238011-2	BLOCK, CRIMPER SPACER	4
-	1	1	1	1	1-456135-6	CRIMPER, INSULATION O PREMIUM	3
-	1	1	1	1	455888-6	SPACER, CRIMPER	2
△	1	1	1	1	4-1633609-3	CRIMPER, WIRE	1

LOC	DIST	REV	DATE	BY	CHK	APPV	DESCRIPTION	SCALE	SIZE	DRAWING NO	SHEET	REV
A	00						RELEASED	1:2	A1	1855604	1	B

LOC  
A  
DIST  
00

-	1	1	1	-	455888-1	SPACER, CRIMPER	189
-	1	1	1	-	6-22279-6	SPRING, COMPRESSION	188
-	2	2	2	-	21024-5	WASHER, SPRG LOCK, REG NO 10	187
-	2	2	2	-	1-21000-9	SCR, SKT HD CAP 6-32 X .375	184
-	2	2	2	-	1-21000-3	SCR, SKT HD CAP 4-40 X .250	183
-	1	1	1	-	690461-2	STOP, SHEAR	180
-	1	1	1	-	2161154-1	HOUSING, SHEAR, FLOATING	179
1	1	1	1	-	2161153-1	FLOATING SHEAR, FRONT	178
-	2	2	2	-	3-21000-9	SCR, SKT HD CAP 10-32 X 1.000	174
-	-	1	-	-	692655-5	AIR FEED VALVE ASSEMBLY	170
-	1	-	1	-	692655-7	AIR FEED VALVE ASSEMBLY	169
-	3	3	3	-	2-22733-8	SCR, BHSC, SELF-LOCKING, 1/4-20 X .625	122
-	4	4	4	-	2-21002-9	SCR, BTN SKT HD CAP 10-32 X .750	121
-	4	4	4	-	3-21002-3	SCR, BTN SKT HD CAP 1/4-20 X .500	120
-	-	REF	-	..	692655-6	AIR FEED VALVE ASSEMBLY	118
-	1	1	1	-	454220-1	CAP, RAM	97
-	1	1	1	-	453736-1	HOUSING, APPLICATOR	95
-	REF	REF	-	..	455745-1	GUARD WINDOW	79



P LTR		REVISION RECORD		DATE	DN	APVD	DIMENSIONS: IN		TOLERANCES UNLESS OTHERWISE SPECIFIED: 0 PLC ±. 1 PLC ±. 2 PLC ±.01 3 PLC ±.001 4 PLC ±.0001		DWN K. STAKEM 25OCT2010		MATERIAL		HEAT TREAT	
- SEE SHEET 1									ANGLE: 0° 30'		CHK G. BAILEY 25OCT2010					
							SURFACE TEXTURE 125		SCALE 1:2		SIZE A1		DRAWING NO 1855604		SHEET 2 OF 2	
											APVD T. ELBIN 25OCT2010				REV B	
											NAME FINE ADJUST END FEED HDM APPLICATOR					