

P.C.B. HOLE DRILLINGS  
(P.C.B. TOP SIDE)

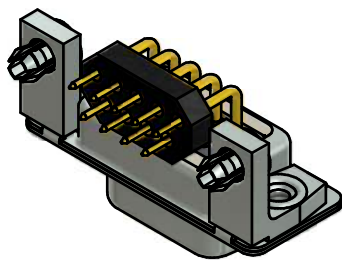
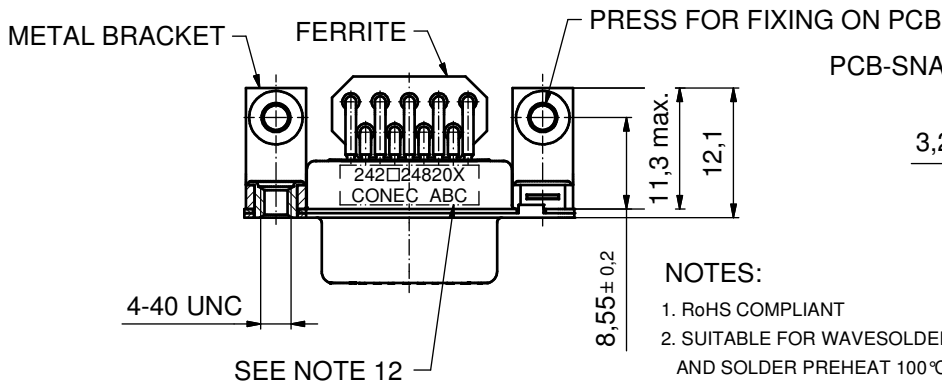
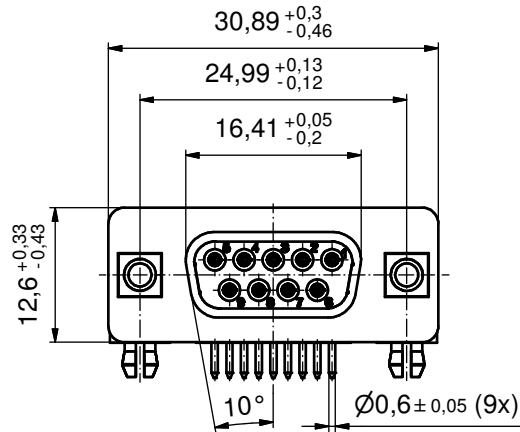
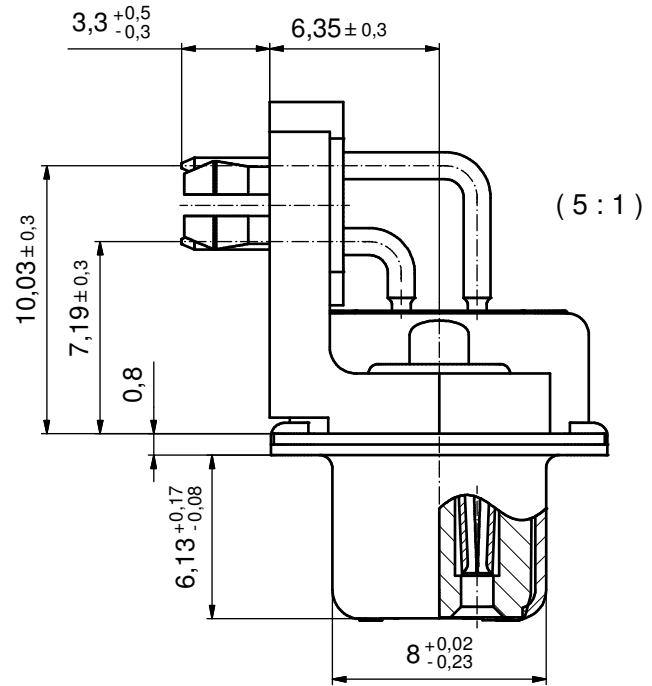

NOTES:

1. RoHS COMPLIANT
2. SUITABLE FOR WAVESOLDERING (SOLDER BATH TEMPERATURE 260°C FOR 5 SEC. AND SOLDER PREHEAT 100°C FOR 30 SEC.)
3. METALSHELLS: STEEL; min. 315µm TIN over 40-80µm NICKEL
4. INSULATOR: HIGH TEMPERATURE PLASTIC UL 94 V-0; BLACK
5. CONTACTS: COPPER ALLOY; PLATING (SEE PART NO.):
  - PLEASE ADD C for 30µm HARD GOLD over min. 50µm NICKEL
  - PLEASE ADD B for 20µm HARD GOLD over min. 50µm NICKEL
  - PLEASE ADD A for GOLD FLASH over min. 50µm NICKEL (PREFERRED TYPE)
6. METAL BRACKETS: ZINC DIE CAST; 300µm COPPER/40-120µm NICKEL/120-200µm TIN
7. THREADED INSERTS: COPPER ALLOY; min. 200µm TIN over 80µm NICKEL
8. PCB-SNAPS: COPPER ALLOY; min. 200µm TIN over 80µm NICKEL  
PCB-HOLE: Ø3,1±0,1; PCB THICKNESS 1,6mm
9. CAPACITANCE: 180pF ±20%
10. DIELECTRIC WITHSTANDING VOLTAGE: 424 VDC
11. MAXIMUM TORQUE VALUE FOR THREAD: 6 in.LB
12. CONNECTOR IS PART MARKED: 242□24820X CONEC ABC (see note 5)

Directive 2002/95/EC RoHS compliant

THIS DRAWING MAY NOT BE COPIED OR REPRODUCED IN ANY WAY, AND MAY NOT BE PASSED ON TO A THIRD PARTY WITHOUT WRITTEN PERMISSION. OWNERSHIP AND COPYRIGHT OF CONEC GmbH DO NOT ALTER CAD DRAWING BY HAND	tolerance		dim. in mm	scale: 2:1 (5:1)	
				material: SEE NOTES	
	drawn	09.07.12	Henneboel	title: <b>D-SUB LC FILTER FEMALE 90°</b> 9pos. SOLDER PIN ANGLED 0.318inch with threaded insert, metal bracket and ferrite	
	appd.	09.07.12	Koch		
norm		d-old		dwg no:	
a	Original			24K1A1395	
rev.	description			date	name
				DIN-A3	
				sh: 1	