

REVISIONS					
REV	ECO	DESCRIPTION	DATE	BY	APPR
B1	-	RELEASE NEW DWG FORMAT	06/16/14	TOD	TOMMY

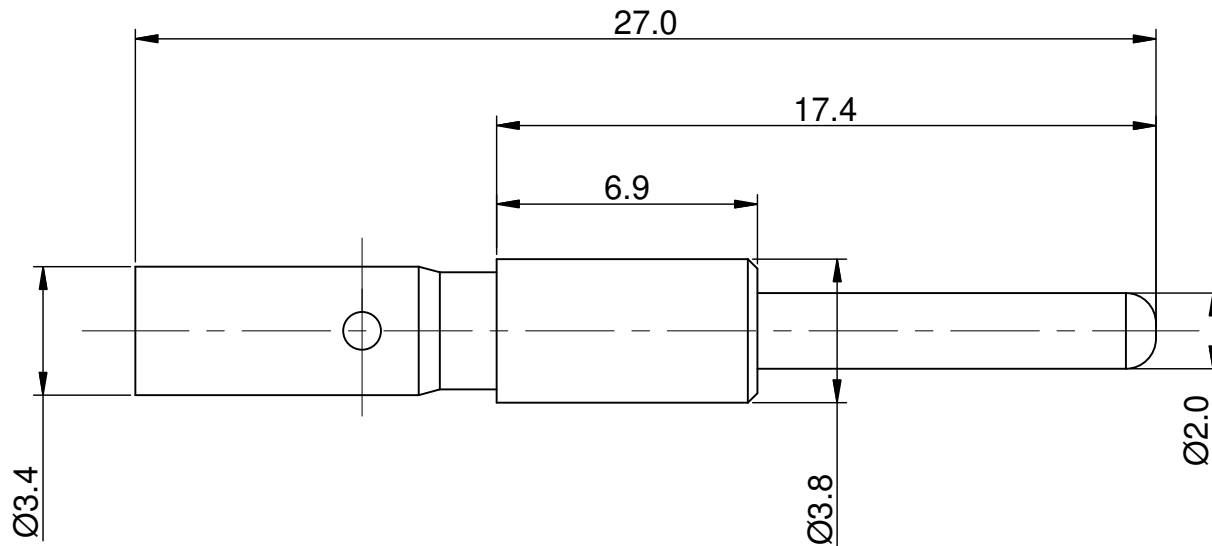
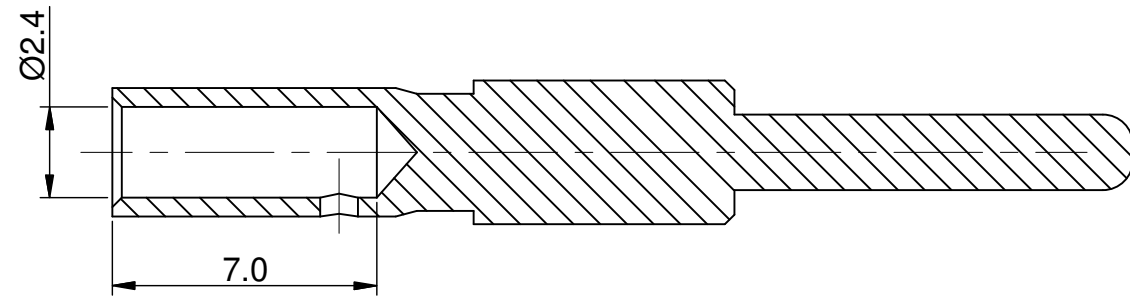

NOTES: UNLESS OTHERWISE SPECIFIED

1. MATERIAL: COPPER ALLOY, GOLD PLATED

2. SPECIFICATIONS:

2.1 RATED CURRENT: 30 AMPS

2.2 CONTACT RESISTANCE: <3 milliohm

2.3 AVAILABLE WIRE RANGE: 18AWG~14AWG

2.4 RoHS COMPLIANT

3. ALL DIMENSIONS ARE FOR REFERENCE USE ONLY.

TITLE: Pin contact, 14# Crimp 18~14AWG

DWG NO: SC000036

REV: B1

SH: 1

OF: 1

QUANTITY	SEE PART NUMBER CHART PART NUMBER	DESCRIPTION	ITEM
<b>MATERIALS LIST</b>			
UNLESS OTHERWISE SPECIFIED 1) All dimensions are in metric(mm). 2) Tolerances are as follows: 1 PL DEC ±0.30 2 PL DEC ±0.15 3 PL DEC ±0.08 Fractions ±1/64 Angles ±1° 3) Note reference =		<b>SIGNATURES</b> DRAWN: Tod CHECKED: ENGINEER: APPROVAL: <b>DATE</b> 06/16/14	<h1 style="text-align: center;">Amphenol</h1> <p style="text-align: center;">Sine Systems - www.amphenol-sine.com            44724 Morley Drive            Clinton Township, MI 48036</p>
MATERIAL SPECIFICATIONS:		CUSTOMER:	Pin contact, 14#, Crimp 18~14AWG
PROCESS SPECIFICATIONS:		THIS DRAWING IS SUPPLIED FOR INFORMATION ONLY. DESIGN FEATURES, SPECIFICATIONS AND PERFORMANCE DATA SHOWN HEREON ARE THE PROPERTY OF THE AMPHENOL CORPORATION. NO RIGHTS OF REPRODUCTION ARE IMPLIED. ALL DIMENSIONS ARE SUBJECT TO NORMAL MANUFACTURING VARIATIONS.	
NEXT ASSY:		SIZE: <b>B</b> TYPE: <b>C-</b> SCALE: NONE	DWG NO: <b>SC000036</b> REVISION: <b>B1</b> SHEET <b>1</b> OF <b>1</b>