

ISL91211A, ISL91211B

Triple/Quad Output PMIC with SPI/I²C Interface

FN8922
Rev.3.01
Mar 5, 2020

The [ISL91211A](#) is a 4-phase, three output programmable Power Management IC (PMIC) and the [ISL91211B](#) is a 4-phase, four output programmable PMIC. They are optimized with highly efficient synchronous buck converters capable of multiphase and single-phase operations that can deliver up to 5A per phase continuous output current. It features four buck controllers and has the capability to reconfigure its power stages to these controllers. This flexibility allows seamless design-in for a wide range of applications that require high output power and small solution size.

ISL91211A and ISL91211B integrate low ON-resistance MOSFETs and programmable PWM frequency, allowing the use of very small external inductors and capacitors. They feature automatic Diode Emulation and Pulse Skipping modes under light-load conditions to further improve efficiency and maximize battery life. The ISL91211A and ISL91211B deliver a highly robust power solution by featuring a controller based on the Renesas proprietary R5 Technology that provides tight output accuracy and load regulation, ultra-fast transient response, seamless DCM/CCM transitions, and requires no external compensation.

In addition to the standard interrupt, chip enable, and watchdog reset functions, ISL91211A and ISL91211B also feature four MPIOs and three GPIOs capable of supporting SPI, I²C communication protocol, and various other pin mode functions.

Applications

- Smartphones, AR/VR Glasses, Drones
- Optical Transceiver Modules
- Artificial Intelligence (AI) Processors
- Client/Enterprise/Data Center SSD, NAS

Features

- Triple output 2+1+1 phases (ISL91211A) or quad output single phase (ISL91211B)
- 2.5V to 5.5V supply voltage
- 5A per phase output current capability
- Small solution size (for four phase design)
- High efficiency (94.7% for 3.8V_{IN}/1.8V_{OUT})
- Low I_Q in low power mode
- Proprietary control scheme reduces output capacitor and supports fast load transient (such as 50A/μs per phase)
- ±0.7% system accuracy, remote voltage sensing
- Programmable PWM frequency from 2MHz to 6MHz
- I²C programmable output from 0.3V to 2V
- Independent Dynamic Voltage Scaling (DVS) for each output
- Soft-start and fault detection (UV, OV, OC, OT), short-circuit protection
- 2.551mmx3.67mm 54 ball WLCSP with 0.4mm pin pitch

Related Literature

For a full list of related documents, visit our website:

- [ISL91211A, ISL91211B](#) device pages
- UG111, “ISL91211AII-EV1Z Evaluation Board User Guide”
- UG116, “ISL91211BII-EV1Z Evaluation Board User Guide”

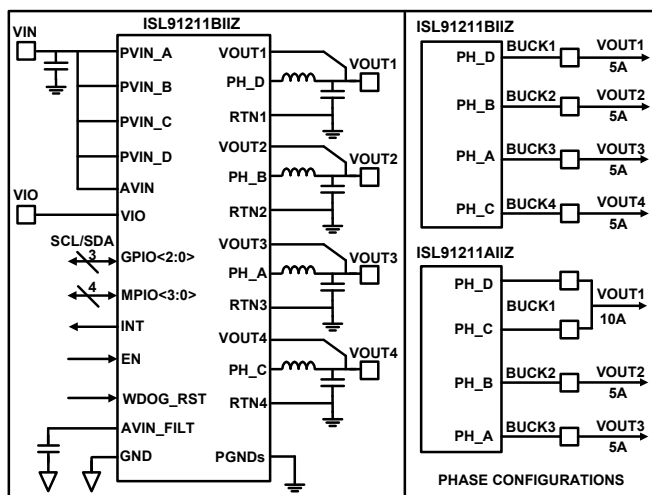

Figure 1. Simplified Block Diagram

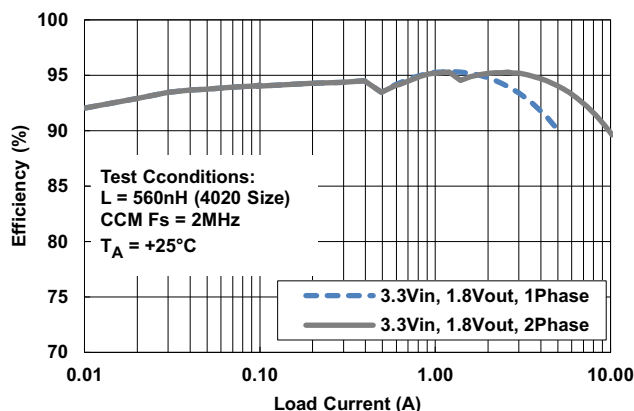

Figure 2. Efficiency vs Load Current

Contents

1. Overview	4
1.1 Typical Application Diagrams	4
1.2 Block Diagram	5
1.3 Ordering Information	6
1.4 Pin Configuration	7
1.5 Pin Descriptions	8
1.6 I/O Pin Configuration	9
2. Specifications	10
2.1 Absolute Maximum Ratings	10
2.2 Thermal Information	10
2.3 Recommended Operating Conditions	10
2.4 Analog Specifications	11
3. Output Configurations	13
4. Typical Operating Performance	15
5. Applications Information	21
5.1 Inductor Selection	21
5.2 Output Capacitor Selection	21
5.3 Input Capacitor Selection	22
5.4 Dynamic Voltage Scaling (DVS)	22
5.5 Configuring DVS Speed	25
5.6 Output Voltage Setting	25
5.7 Power Sequencing	25
5.8 Watchdog Time (WDOG_RST Pin)	27
5.9 Interrupt Pin	28
6. Protection Features (FAULTS)	29
6.1 Over-Temperature Protection	29
6.2 Overcurrent Protection Mode	29
6.3 Overvoltage (OV)/Undervoltage (UV) Protection	29
7. Serial Communication Interface	30
7.1 The SPI Interface	30
7.2 The I ² C Interface	33
8. Board Layout Recommendations	37
8.1 PCB Layout Summary	38
8.2 PCB Design for WLCSP Recommendations	39

9.	Register Address Map	40
10.	Register Description by Address	41
11.	Revision History	55
12.	Package Outline Drawing	56

1. Overview

1.1 Typical Application Diagrams

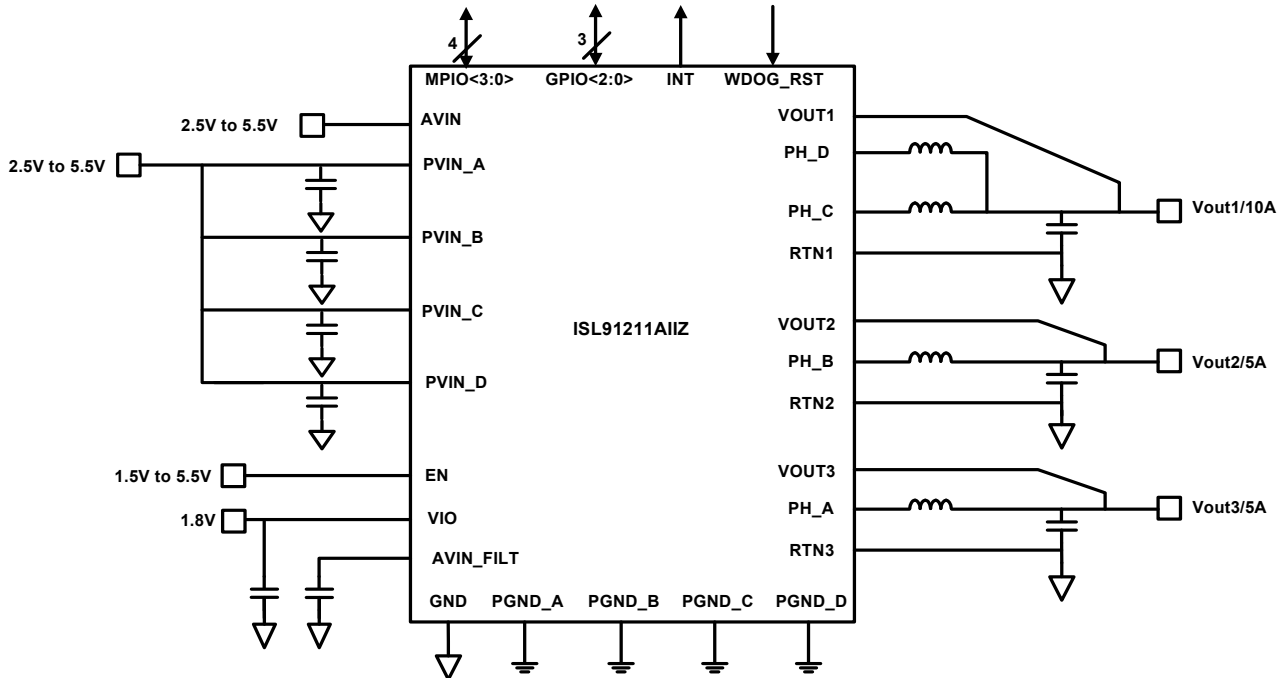

Figure 3. 2 Phase + 1 Phase + 1 Phase

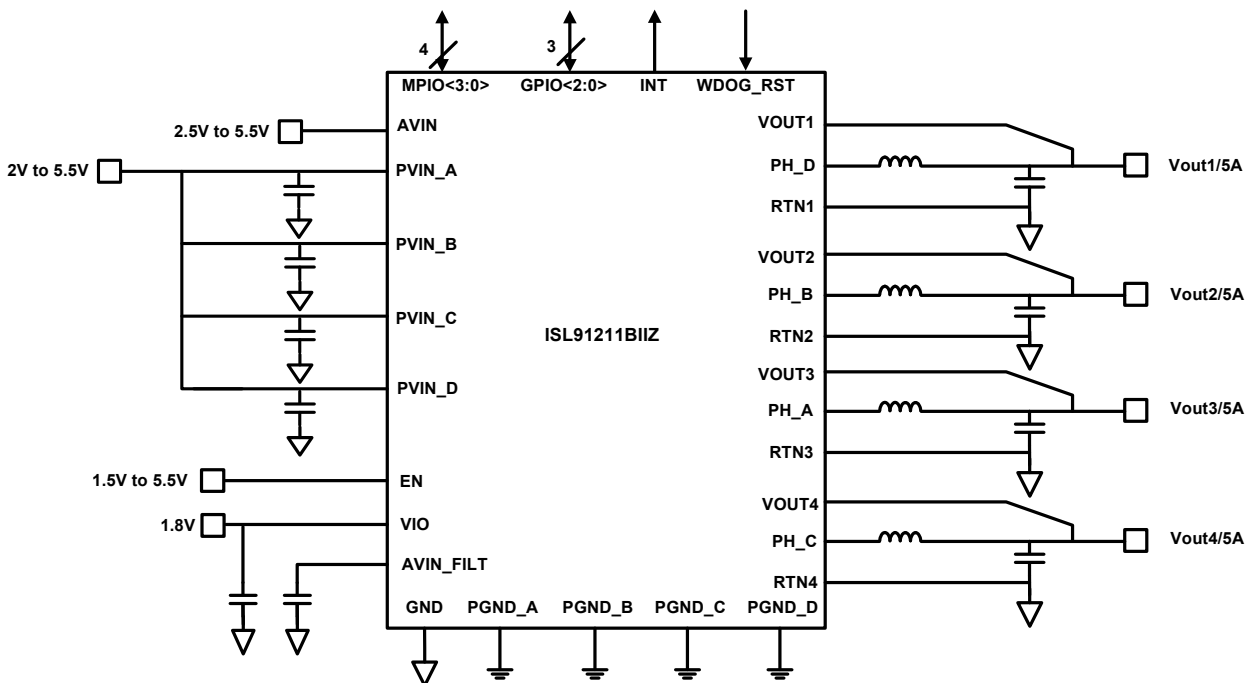

Figure 4. 1 Phase + 1 Phase + 1 Phase + 1 Phase

1.2 Block Diagram

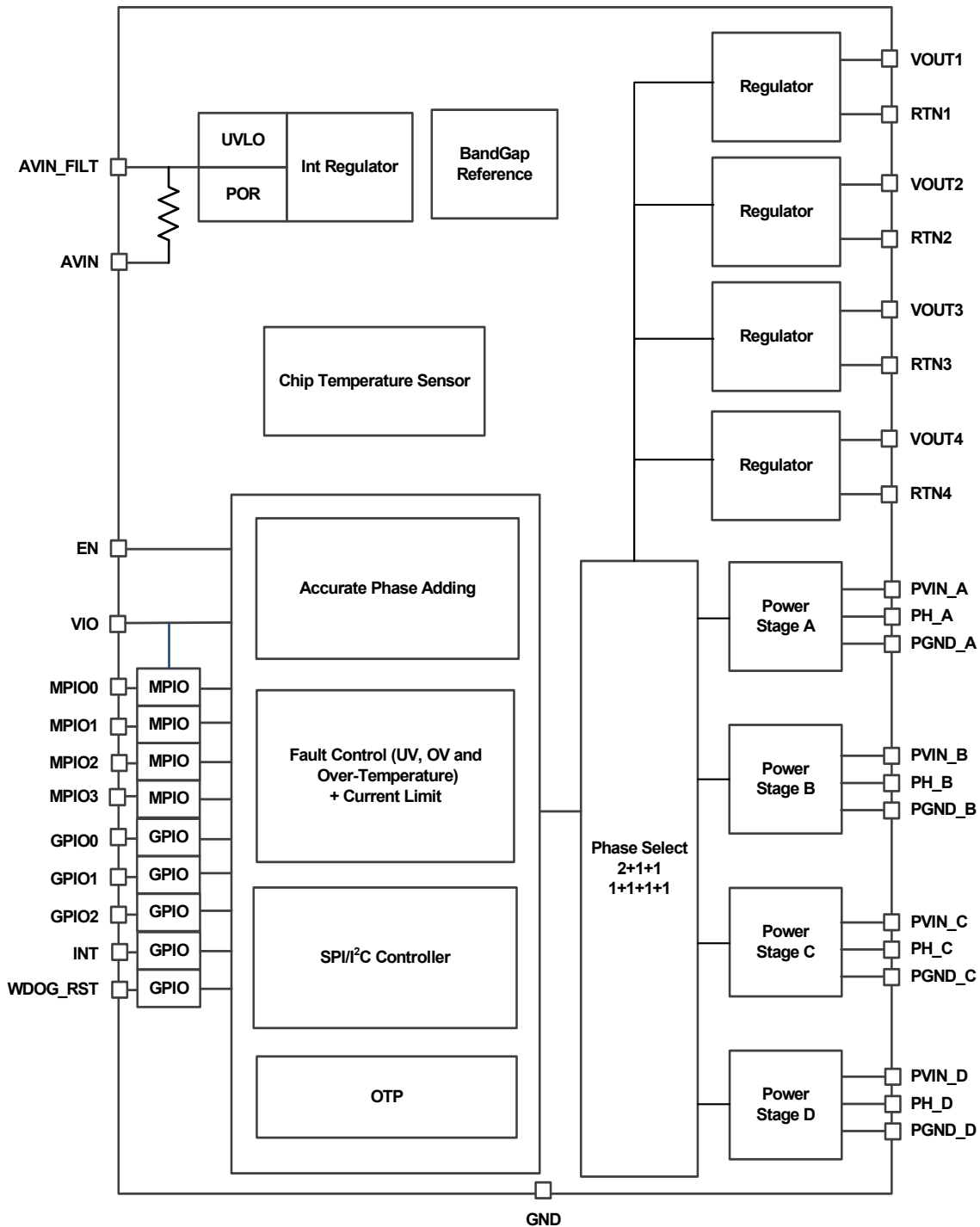

Figure 5. Block Diagram

1.3 Ordering Information

Part Number (Notes 1, 3, 4)	Part Marking	Temp Range (°C)	Tape and Reel (Units) (Note 2)	Package (RoHS Compliant)	Pkg. Dwg #
ISL91211AIIZ-T	211A	-40 to +85	3k	2.551mmx3.670mm, 54 Ball WLCSP	W6x9.54
ISL91211BIIZ-T	211B	-40 to +85	3k	2.551mmx3.670mm, 54 Ball WLCSP	W6x9.54
ISL91211AII-EV1Z	Evaluation Board				
ISL91211BII-EV1Z	Evaluation Board				

Notes:

- For additional part options contact your local sales office.
- See [TB347](#) for details about reel specifications.
- These Pb-free WLCSP packaged products employ special Pb-free material sets; molding compounds/die attach materials and SnAgCu - e6 solder ball terminals, which are RoHS compliant and compatible with both SnPb and Pb-free soldering operations. Pb-free WLCSP packaged products are MSL classified at Pb-free peak reflow temperatures that meet or exceed the Pb-free requirements of IPC/JEDEC J-STD-020.
- For Moisture Sensitivity Level (MSL), see the [ISL91211A](#), [ISL91211B](#) device pages. For more information about MSL, see [TB363](#).

Table 1. Key Differences Between Family of Parts

Part Number	Pin Configuration	Pitch	Output Configuration	Load per Phase
ISL91302B	54 Ball 6x9 WLCSP	0.4mm	Single Output (4 + 0 Phase)	5A
	54 Ball 6x9 WLCSP	0.4mm	Dual Output (3 + 1 Phase)	5A
	54 Ball 6x9 WLCSP	0.4mm	Dual Output (2 + 2 Phase)	5A
ISL91301A	42 Ball 6x7 WLCSP	0.4mm	Triple Output (2+1+1 Phase)	4A
ISL91301B	42 Ball 6x7 WLCSP	0.4mm	Quad Output (1+1+1+1 Phase)	4A
ISL91211A	54 Ball 6x9 WLCSP	0.4mm	Triple Output (2+1+1 Phase)	5A
ISL91211B	54 Ball 6x9 WLCSP	0.4mm	Quad Output (1+1+1+1 Phase)	5A
ISL91212A	35 Ball 5x7 WLCSP	0.5mm	Triple Output (2+1+1 Phase)	5A
ISL91212B	35 Ball 5x7 WLCSP	0.5mm	Quad Output (1+1+1+1 Phase)	5A

1.4 Pin Configuration

54 Ball 6x9 WLCSP
Top View

JEDEC Standard:
Balls Down, A1 Top Left Corner

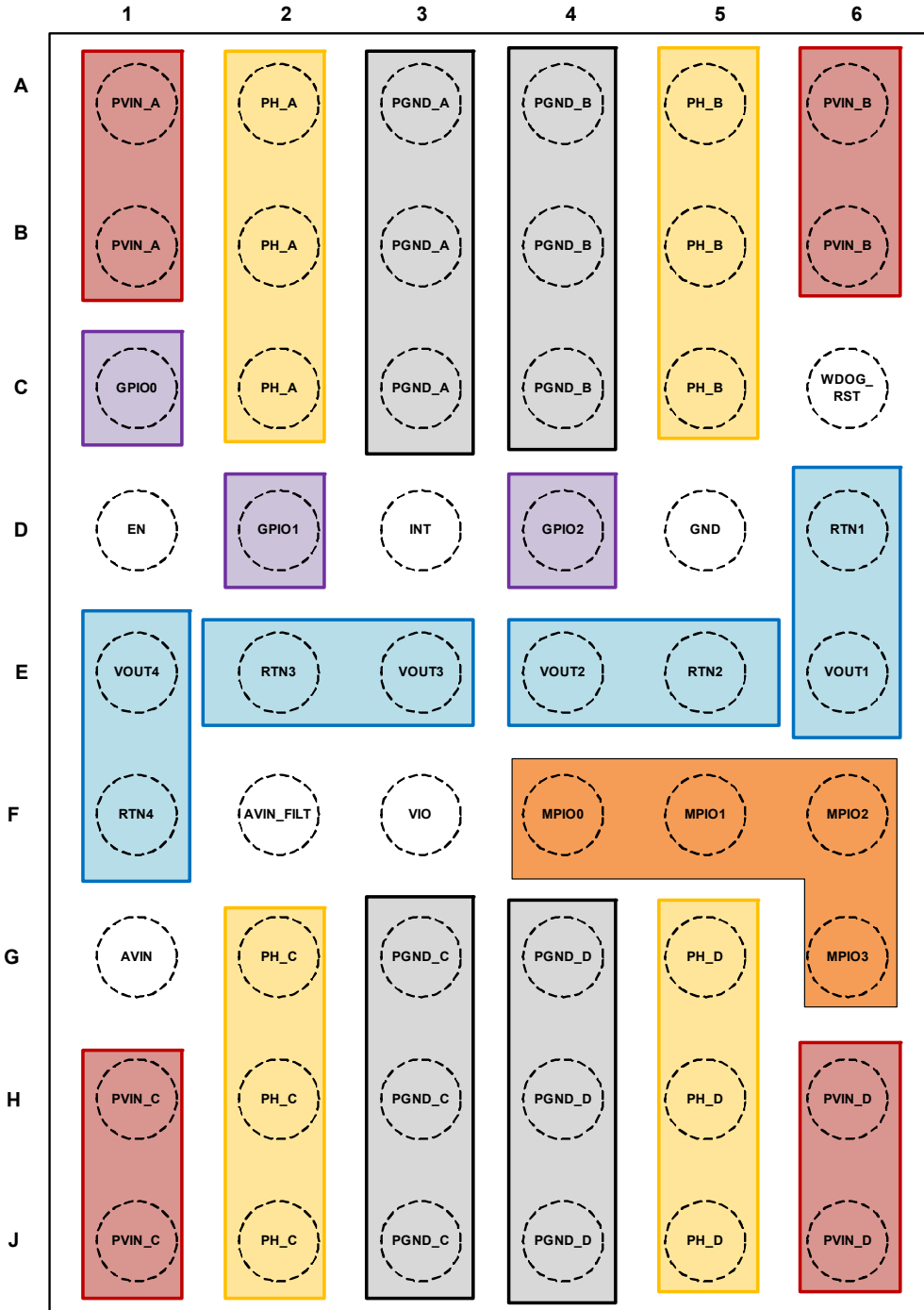

1.5 Pin Descriptions

Pin Location	Pin Name	Type	Description
A1, B1	PVIN_A	Input	Power supply for Power Stage A.
A2, B2, C2	PH_A	Output	Switching node for Power Stage A.
A3, B3, C3	PGND_A	Input	Ground connection for Power Stage A.
A4, B4, C4	PGND_B	Input	Ground connection for Power Stage B.
A5, B5, C5	PH_B	Output	Switching node for Power Stage B.
A6, B6	PVIN_B	Input	Power supply for Power Stage B.
C1	GPIO0	Input	GPIO0. See Table 2 on page 9 . This pin is I ² C clock for pinmodes 0x0, 0x2, 0x4 through 0x7 and 0xC.
C6	WDOG_RST	Input	Digital input, resets bucks to default output voltage.
D1	EN	Input	Master chip enable input, NMOS logic threshold.
D2	GPIO1	Input/Output	GPIO1. See Table 2 on page 9 . This pin is I ² C data for pinmodes 0x0, 0x2, 0x4 through 0x7 and 0xC.
D3	INT	Output	Interrupt line.
D4	GPIO2	Input	GPIO2. See Table 2 on page 9 .
D5	GND	Input	Analog chip ground.
D6	RTN1	Input	Remote ground sense for Buck1.
E1	VOUT4	Input	Buck4 output voltage sense for ISL91211B. NOTE: Short to ground for ISL91211A.
E2	RTN3	Input	Remote ground sense for Buck3.
E3	VOUT3	Input	Output voltage sense for Buck3.
E4	VOUT2	Input	Output voltage sense for Buck2.
E5	RTN2	Input	Remote ground sense for Buck2.
E6	VOUT1	Input	Remote output voltage sense for Buck1.
F1	RTN4	Input	Buck4 output voltage sense for ISL91211B. NOTE: Short to ground for ISL91211A.
F2	AVIN_FILT	Output	Filtered analog supply voltage, 2.5V to 5.5V. Place a decoupling capacitor close to the IC.
F3	VIO	Input	I/O supply voltage for digital communications. Nominally connected to 1.8V supply.
F4	MPIO0	Input/Output	Multipurpose I/O, see Table 2 on page 9 . Can be NC if not used.
F5	MPIO1	Input/Output	Multipurpose I/O, see Table 2 on page 9 . Can be NC if not used. Must be pulled up to VIO if using I ² C.
F6	MPIO2	Input/Output	Multipurpose I/O, see Table 2 on page 9 . Can be NC if not used.
G1	AVIN	Input	Analog supply voltage, 2.5V to 5.5V.
G2, H2, J2	PH_C	Output	Switching node for Power Stage C.
G3, H3, J3	PGND_C	Input	Ground connection for Power Stage C.
G4, H4, J4	PGND_D	Input	Ground connection for Power Stage D.
G5, H5, J5	PH_D	Output	Switching node for Power Stage D.
G6	MPIO3	Input/Output	Multipurpose I/O, see Table 2 on page 9 . Can be NC if not used.
H1, J1	PVIN_C	Input	Power supply connection for Power Stage C.
H6, J6	PVIN_D	Input	Power supply connection for Power Stage D.

1.6 I/O Pin Configuration

The ISL91211 features three “General Purpose” I/O pins for I²C and other functions along with four “Multipurpose” I/O pins. These pins can perform different functions depending on the “IO_PINMODE” setting. The default factory setting for IO_PINMODE is 0x0. For features that require “IO_PINMODE” to be different than the default value, contact [Renesas](#) for factory OTP programming.

Table 2. I/O Pin Mode

IO_PINMODE	MPIO0	MPIO1	MPIO2	MPIO3	GPIO0	GPIO1	GPIO2	Description
0x0	SCK	SS_B	MOSI	MISO	I2C_CLK	I2C_SDA	N/A	I ² C/SPI both available
0x1	SCK	SS_B	MOSI	MISO	EN_A	EN_B	EN_C	SPI mode with hardware enables for Bucks 1-3
0x2	PGOOD1	PGOOD2	PGOOD3	PGOOD4	I2C_CLK	I2C_SDA	N/A	I ² C with Individual PGOODs for Bucks1-4
0x3	SCK	SS_B	MOSI	MISO	DVS_A	DVS_B	DVS_C	SPI with hardware DVS pins
0x4	DVS_PIN1	DVS_PIN0	PGOOD1	PGOOD2	I2C_CLK	I2C_SDA	N/A	I ² C with Global DVS mode with PGOOD1 and PGOOD2
0x5	BUCK1_DVS0	BUCK1_DVS1	BUCK2_DVS0	BUCK2_DVS1	I2C_CLK	I2C_SDA	N/A	I ² C with full pin controlled DVS for BUCK1/BUCK2
0x6	BUCK1_DVS0	BUCK1_DVS1	BUCK2_DVS0	BUCK3_DVS0	I2C_CLK	I2C_SDA	N/A	I ² C with full DVS for Buck 1, 1-pin DVS for BUCK2/BUCK3
0x7	BUCK1_DVS0	BUCK2_DVS0	BUCK3_DVS0	BUCK4_DVS0	I2C_CLK	I2C_SDA	N/A	I ² C with 1-pin DVS for each buck
0xC	MPIO_DATA [0]	MPIO_DATA [1]	MPIO_DATA [2]	MPIO_DATA [3]	I2C_CLK	I2C_SDA	N/A	I ² C with 4 parallel controllable data lines.

NOTE: Pinmodes 0x8 through 0xB and 0xD through 0xF are reserved.

Table 3. Pin Mode Description

Name	Definition
SCK	SPI clock
SS_B	SPI/I ² C selector. Low = SPI, High = I ² C.
MOSI	SPI master out, slave in
MISO	SPI master in, slave out
I2C_CLK	I ² C clock
I2C_SDA	I ² C data
PGOOD1, PGOOD2, PGOOD3, PGOOD4	Four power-good out pins (one per buck)
EN_A, EN_B, EN_C	Three buck enable input pins. A single buck enable pin can enable/disable up to four bucks. A buck's enable/disable can be controlled from only one enable pin (EN_A, EN_B, or EN_C).
DVS_A, DVS_B, DVS_C	Three DVS input pins. A single DVS pin can control the DVS voltage for up to four bucks. A buck's DVS voltage can be controlled from only one DVS pin (DVS_A, DVS_B, or DVS_C).
DVS_PIN1, DVS_PIN0	DVS look-up table to allow two pins to control up to four bucks.

2. Specifications

2.1 Absolute Maximum Ratings

Parameter	Minimum	Maximum	Unit
PVIN and AVIN Pins to PGND	-0.3	6	V
VOUT Pin (BUCKx_VOUTFBDIV[1:0] = 0x00)	-0.3	+2.0	V
VOUT Pin (BUCKx_VOUTFBDIV[1:0] = 0x01)	-0.3	+2.4	V
VOUT Pin (BUCKx_VOUTFBDIV[1:0] = 0x02)	-0.3	+3.0	V
PH to PGND	-0.3	0.3 + PVIN	V
VIO, EN Pins to GND	-0.3	0.3 + AVIN	V
RTN, GND to PGND	-0.3	0.3	V
INT, MPIO, GPIO Pins to GND	-0.3	+0.3 + VIO	V
ESD Rating (Note 5)	Value		Unit
Human Body Model (Tested per JESD22-A114E)	2		kV
Charged Device Model (Tested per JESD22-C101)	750		V
Latch-Up (Tested per JESD-78B; Class 2, Level A)	100		mA

CAUTION: Do not operate at or near the maximum ratings listed for extended periods of time. Exposure to such conditions can adversely impact product reliability and result in failures not covered by warranty.

Note:

5. ESD ratings apply to external pins only.

2.2 Thermal Information

Thermal Resistance (Typical)	θ_{JA} (°C/W)	θ_{JC} (°C/W)
54 Ball 6x9 WLCSP Package (Notes 6, 7)	42	0.5

Notes:

6. θ_{JA} is measured in free air with the component mounted on a high-effective thermal conductivity test board with direct attach features. See [TB379](#).
 7. For θ_{JC} , the case temperature location is taken at the package top center.

Parameter	Minimum	Maximum	Unit
Maximum Junction Temperature		+150	°C
Maximum Storage Temperature Range	-65	+150	°C
Pb-Free Reflow Profile	See TB493		

2.3 Recommended Operating Conditions

Parameter	Minimum	Maximum	Unit
Junction Temperature	-40	+125	°C
Supply Voltage			
(AVIN to GND)	2.5	5.5	V
(PVIN to GND)	2.5	5.5	V
VIO Voltage (VIO to PGND)	1.7	AVIN	V
INT, MPIO, GPIO Pins to GND	0	VIO	V

2.4 Analog Specifications

AVIN/PVIN = 3.7V, V_{OUT} = 1V, L = 220nH, Frequency = 4MHz, V_{IO} = 1.8V, T_A = +25°C. **Boldface limits apply across the operating temperature range, -40°C to +85°C.**

Parameter	Symbol	Test Conditions	Min (Note 8)	Typ	Max (Note 8)	Unit	
Input Supply							
Supply Voltage	AVIN		2.5		5.5	V	
Supply Voltage	PVIN		2.5		5.5	V	
AVIN Supply Current	I _Q	EN = 0V		0.1	1	μA	
AVIN + PVINx Supply Current		EN = 0V		<1	6	μA	
AVIN + PVINx Supply Current EN = AVIN = PVINx = 3.7V		All BUCK's EN[0] = 0x0			17		μA
		BUCK1_EN[0] = 0x1, all other BUCK's EN[0] = 0x0, not switching DCM operation			82		μA
		BUCK2, 3 or 4_EN[0] = 0x1, all other BUCK's EN[0] = 0x0, not switching DCM operation			62		μA
		BUCK1_EN[0] = 0x1, all other BUCK's EN[0] = 0x0, not switching, forced CCM operation			1.2		mA
		BUCK2, 3 or 4_EN[0] = 0x1, all other BUCK's EN[0] = 0x0, not switching, forced CCM operation			1		mA
AVIN UVLO Rising Threshold	VUVLOR		2.50	2.58	2.65	V	
AVIN UVLO Falling Threshold	VUVLOF		2.29	2.34	2.39	V	
Buck Regulation							
Buck Output Voltage Range (Each Output)	V _{OUT}	BUCKx_VOUTFBDIV[1:0] = 0x00	0.300		1.2	V	
		BUCKx_VOUTFBDIV[1:0] = 0x01	0.375		1.5	V	
		BUCKx_VOUTFBDIV[1:0] = 0x02	0.500		2.0	V	
Output Voltage Step Size	V _{STEP}	10-bit control, BUCKx_VOUTFBDIV[1:0] = 0x00		1.2		mV	
		10-bit control, BUCKx_VOUTFBDIV[1:0] = 0x01		1.5		mV	
		10-bit control, BUCKx_VOUTFBDIV[1:0] = 0x02		2.0		mV	
Output Voltage Accuracy (Note 9)	V _{ACC}	CCM, V _{OUT} > 0.6V	-0.3		0.3	%	
		CCM, V _{OUT} > 0.6V T _A = -10°C to +85°C	-0.7		0.7	%	
		CCM, V _{OUT} < 0.6V	-4		4	mV	
		CCM, V _{OUT} < 0.6V T _A = -10°C to +85°C	-5.5		5.5	mV	
Current Matching	I _{MATCH}	I _{OUT} = 5A per phase in ISL91211A		10		%	
Dynamic Response							
Boot-Up Time	V _{BT}	Delay time from when PVIN, AVIN, and EN are asserted to Buck1 PWM switching. This time includes internal reference startup, OTP load, and Buck controller calibration time.		1.4		ms	
Dynamic Voltage Scaling (Output Slew Rate)	V _{DVS}	2.5V < V _{IN} < 5.5V 3mV/μs	-15		15	%	

AVIN/PVIN = 3.7V, V_{OUT} = 1V, L = 220nH, Frequency = 4MHz, V_{IO} = 1.8V, T_A = +25°C. **Boldface limits apply across the operating temperature range, -40°C to +85°C. (Continued)**

Parameter	Symbol	Test Conditions	Min (Note 8)	Typ	Max (Note 8)	Unit
Frequency						
Switching Frequency (CCM)	f _{sw}			4		MHz
CCM Frequency Tolerance	f _{sw_TOL}		-15		15	%
Power Stage						
Buck Output Current (Each Phase)		2.5V < V _{IN} < 5.5V			5	A
High-Side Switch ON-Resistance	HS r _{DS(ON)}			23		mΩ
Low-Side Switch ON-Resistance	LS r _{DS(ON)}			9		mΩ
MPIO/GPIO						
MPIO/GPIO Operating Conditions						
Allowable Range of Supply for Operation	V _{IO}		1.7	1.8	AV_{IN}	V
Chip Enable Logic Threshold Level						
Low-Level Input Voltage Range	V _{IL}				0.5	V
High-Level Input Voltage	V _{IH}		1.35			V
MPIO/GPIO Logic Threshold Levels						
Low-Level Input Voltage Range	V _{IL}				0.25 * V_{IO}	V
High-Level Input Voltage	V _{IH}		0.75 * V_{IO}			V
Hysteresis On Input	V _{HYS}		0.1 * V_{IO}			V
Low-Level Output	V _{OL}	1mA			0.4	V
High-Level Output	V _{OH}	1mA	V_{IO} - 0.4			V
Serial Interfaces						
I ² C Frequency Capability	f _{I2C}				3.4	MHz
SPI Frequency Capability	f _{SPI}			26		MHz
Protection						
HSD Current Limit	I _{LIMIT}	2.5V < V _{IN} < 5.5V ISL91211A Phase D, OC = 12A	-10		10	%
		2.5V < V _{IN} < 5.5V ISL91211A Phase A, B, OC = 8A	-10		10	%
		2.5V < V _{IN} < 5.5V ISL91211B Phase A, B, C, D, OC = 8A	-10		10	%
Output UVP Threshold Accuracy	V _{UVP}	Thresholds: -250mV	-35		35	mV
Output OVP Threshold Accuracy	V _{OVP}	Thresholds: +250mV	-35		35	mV
Thermal Shutdown Threshold	T _{SPS}	2.5V < V _{IN} < 5.5V	143		162	°C
		Hysteresis		55		°C

Notes:

8. Parameters with MIN and/or MAX limits established by test, characterization, and/or design.
9. V_{OUT} feedback divider ratio equals 1 (BUCKx_VOUTFBDIV[1:0] = 0x00).

3. Output Configurations

Table 4. Output Configurations

Output Configuration	Power Stage Assignment	Diagram
2-phase + 1-phase + 1-phase Connect: VOUT4/RTN4 to PGND Plane	2-phase: Controller #1 (VOUT1) • Ph1: PH_D • Ph2: PH_C 1-phase: Controller #2 (VOUT2) • Ph1: PH_B 1-phase: Controller #3 (VOUT3) • Ph1: PH_A	<p style="text-align: center;">ISL91211A Configuration</p> <p>The diagram shows a 6x8 pin grid for the ISL91211A. The pins are labeled as follows:</p> <ul style="list-style-type: none"> Row 1: PVIN_A, PH_A, PGND_A, PGND_B, PH_B, PVIN_B Row 2: PVIN_A, PH_A, PGND_A, PGND_B, PH_B, PVIN_B Row 3: GPIO0, PH_A, PGND_A, PGND_B, PH_B, WDOG_RST Row 4: EN, GPIO1, INT, GPIO2, GND, RTN4 Row 5: VOUT4, RTN3, VOUT3, VOUT2, RTN2, VOUT1 Row 6: RST4, AVIN_FILT, VIO, MPIO0, MPIO1, MPIO2 Row 7: AVIN, PH_C, PGND_C, PGND_D, PH_D, MPIO3 Row 8: PVIN_C, PH_C, PGND_C, PGND_D, PH_D, PVIN_D Row 9: PVIN_C, PH_C, PGND_C, PGND_D, PH_D, PVIN_D <p>Connections shown in the diagram:</p> <ul style="list-style-type: none"> Blue connections: VOUT1 and RTN1 are connected to PH_D and PH_C. RTN4 is connected to VOUT4 and RST4. A ground symbol is connected to RTN4. Red connections: VOUT2 and RTN2 are connected to PH_B. Green connections: VOUT3 and RTN3 are connected to PH_A.

Table 4. Output Configurations (Continued)

Output Configuration	Power Stage Assignment	Diagram
1-phase + 1-phase + 1-phase + 1-phase	1-phase: Controller #1 (VOUT1) • Ph1: PH_D 1-phase: Controller #2 (VOUT2) • Ph1: PH_B 1-phase: Controller #3 (VOUT3) • Ph1: PH_A 1-phase: Controller #4 (VOUT4) • Ph1: PH_C	<p style="text-align: center;">ISL91211B Configuration</p> <p>The diagram shows a 10x6 grid of pins. Connections are as follows: - VOUT1 (blue) connects to PH_D (blue) and RTN1 (blue). - VOUT2 (red) connects to PH_B (red) and RTN2 (red). - VOUT3 (green) connects to PH_A (green) and RTN3 (green). - VOUT4 (purple) connects to PH_C (purple) and RTN4 (purple).</p>

4. Typical Operating Performance

Unless otherwise noted, operating conditions are: $V_{IN} = 3.8V$, $V_{OUT} = 1V$, V_{IO} and $Enable = 1.8V$, $T_A = +25^\circ C$, $f_{SW} = 4MHz$, 2+1+1 configuration, $L = 220nH$ per phase, SW1: $C_{OUT} = 2 \times 22\mu F + 2 \times 4.3\mu F + 4 \times 1\mu F$, SW2-3: $C_{OUT} = 1 \times 22\mu F + 4 \times 4.3\mu F$.

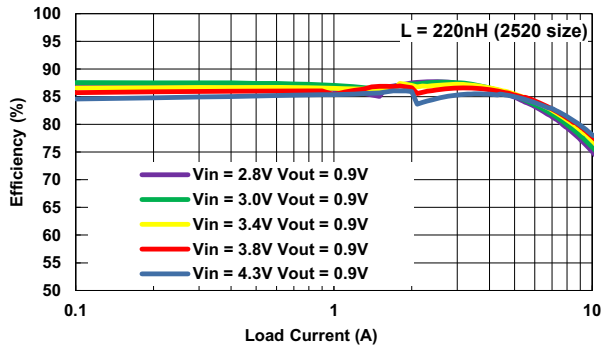

Figure 6. Dual-Phase Efficiency ($V_{OUT} = 0.9V$), Continuous Load Sweep (0.1A to 10A)

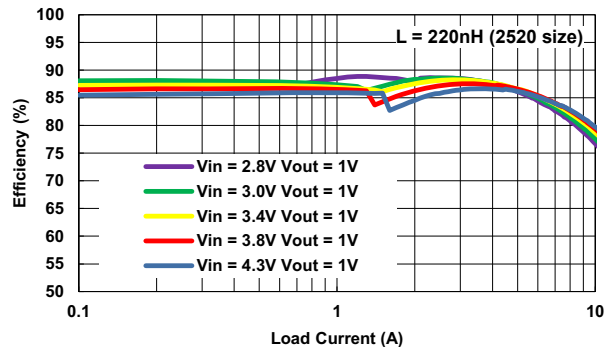

Figure 7. Dual-Phase Efficiency ($V_{OUT} = 1V$), Continuous Load Sweep (0.1A to 10A)

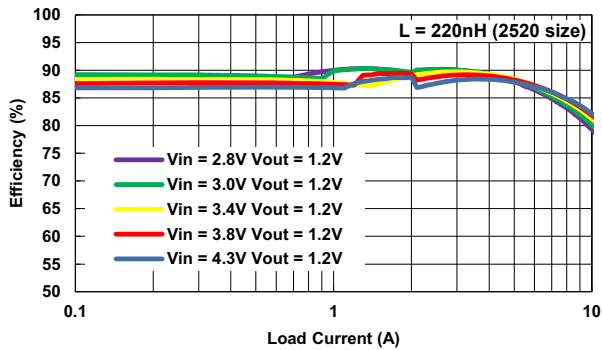

Figure 8. Dual-Phase Efficiency ($V_{OUT} = 1.2V$), Continuous Load Sweep (0.1A to 10A)

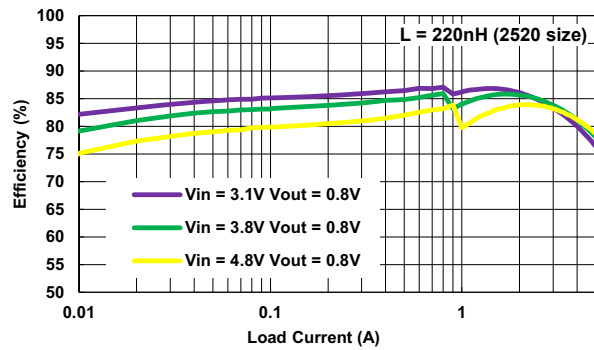

Figure 9. Single-Phase Efficiency ($V_{OUT} = 0.8V$), Continuous Load Sweep (0.01A to 5A)

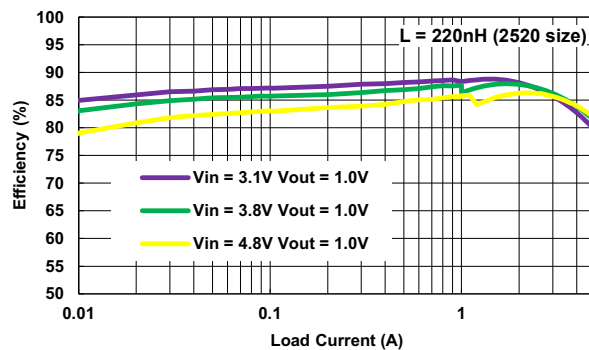

Figure 10. Single-Phase Efficiency ($V_{OUT} = 1V$), Continuous Load Sweep (0.01A to 5A)

Unless otherwise noted, operating conditions are: $V_{IN} = 3.8V$, $V_{OUT} = 1V$, V_{IO} and Enable = 1.8V, $T_A = +25^\circ C$, $f_{SW} = 4MHz$, 2+1+1 configuration, $L = 220nH$ per phase, SW1: $C_{OUT} = 2x22\mu F + 2x4.3\mu F + 4x1\mu F$, SW2-3: $C_{OUT} = 1x22\mu F + 4x4.3\mu F$. (Continued)

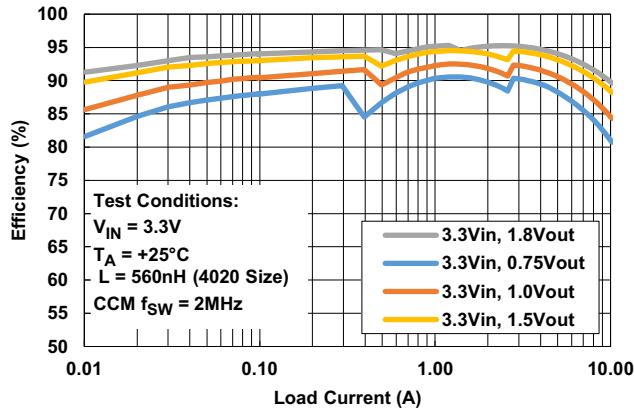

Figure 11. 2 Phase Efficiency $V_{IN} = 3.3V$

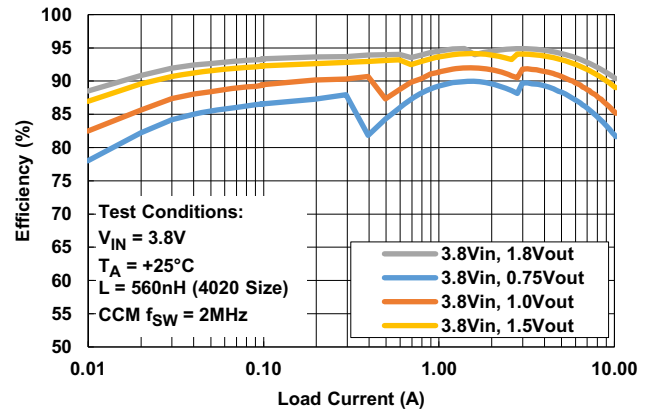

Figure 12. 2 Phase Efficiency $V_{IN} = 3.8V$

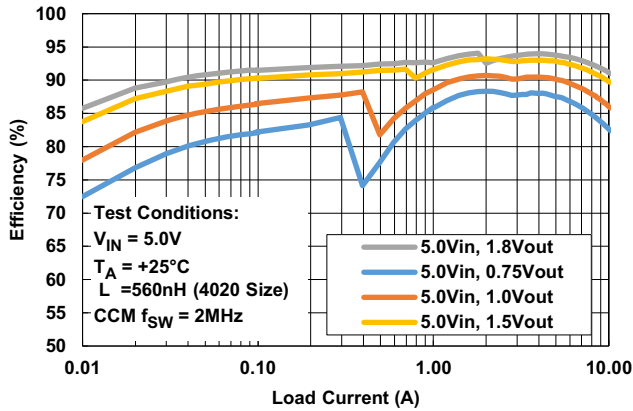

Figure 13. 2 Phase Efficiency $V_{IN} = 5.0V$

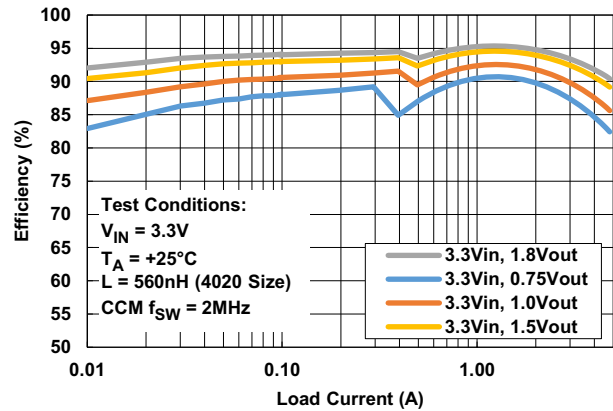

Figure 14. Single Phase Efficiency $V_{IN} = 3.3V$

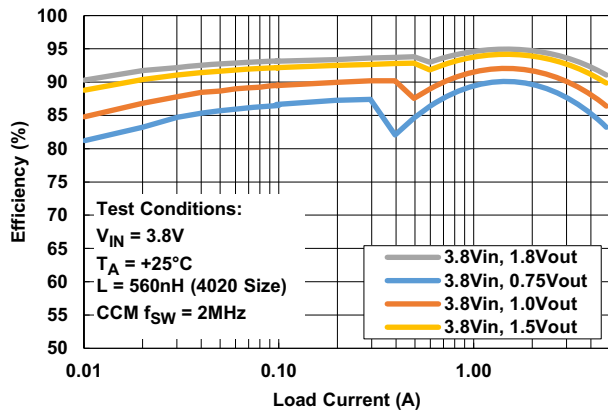

Figure 15. Single Phase Efficiency $V_{IN} = 3.8V$

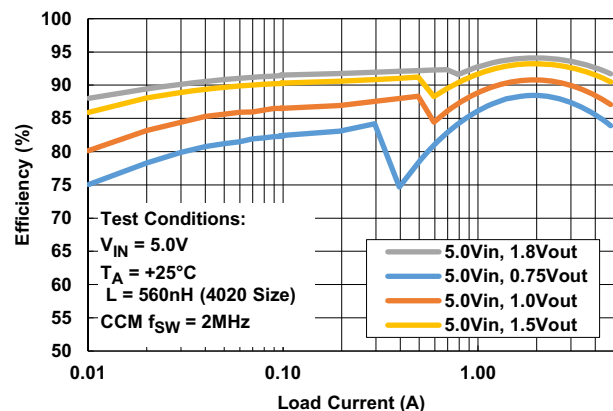
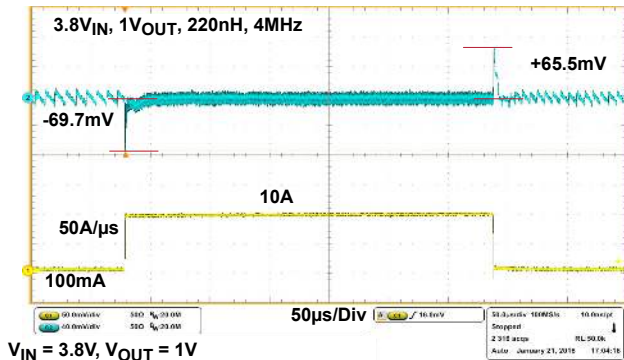

Figure 16. Single Phase Efficiency $V_{IN} = 5.0V$

Unless otherwise noted, operating conditions are: $V_{IN} = 3.8V$, $V_{OUT} = 1V$, V_{IO} and Enable = 1.8V, $T_A = +25^\circ C$, $f_{SW} = 4MHz$, 2+1+1 configuration, L = 220nH per phase, SW1: $C_{OUT} = 2 \times 22\mu F + 2 \times 4.3\mu F + 4 \times 1\mu F$, SW2-3: $C_{OUT} = 1 \times 22\mu F + 4 \times 4.3\mu F$. (Continued)



$V_{IN} = 3.8V$, $V_{OUT} = 1V$
 Load Step Slew Rate: 50A/μs, 0.1A to 10A
 220nH Inductor (Cyntec)
 3x22μF Capacitor (0603 6.3V Murata)
 6x4.7μF Capacitor (0603 10V)

Figure 17. Dual-Phase Load Transient (10A/200ns)

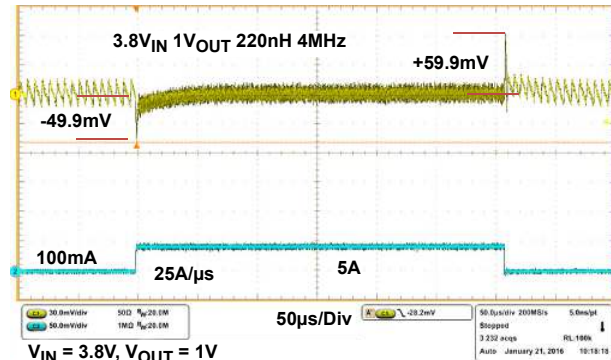

$V_{IN} = 3.8V$, $V_{OUT} = 1V$
 Load Step Slew Rate: 25A/μs, 0.1A to 5A
 220nH Inductor (Cyntec)
 1x22μF Capacitor (0603 6.3V Murata)
 6x4.3μF Capacitor (Low ESL)

Figure 18. Single-Phase Transient (5A/200ns)

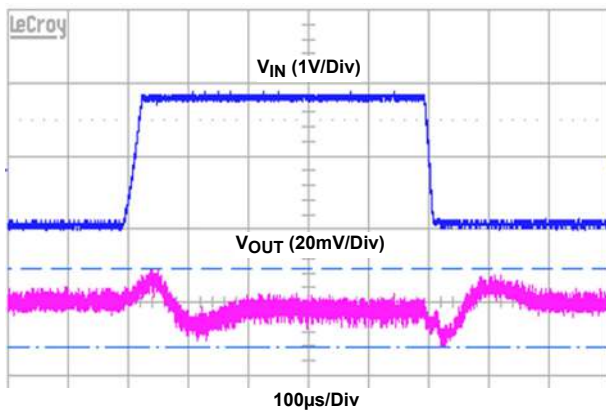

Figure 19. Dual-Phase Line Transient, $V_{OUT} = 1V$, $V_{IN} = 3.1V$ to 4.8V, Load = 8A, TR and TF = 15μs

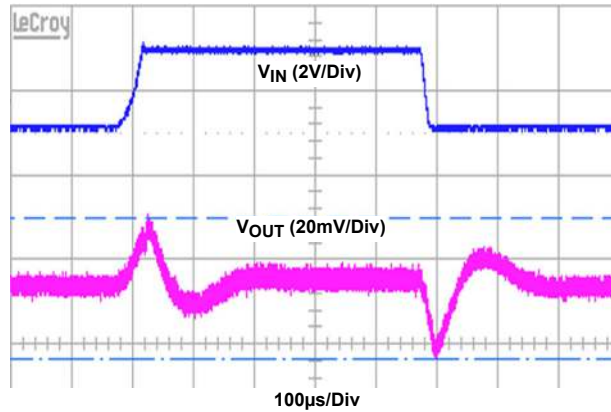

Figure 20. Single-Phase Line Transient, $V_{OUT} = 1V$, $V_{IN} = 3.1$ to 4.8V, Load = 5A, TR and TF = 15μs

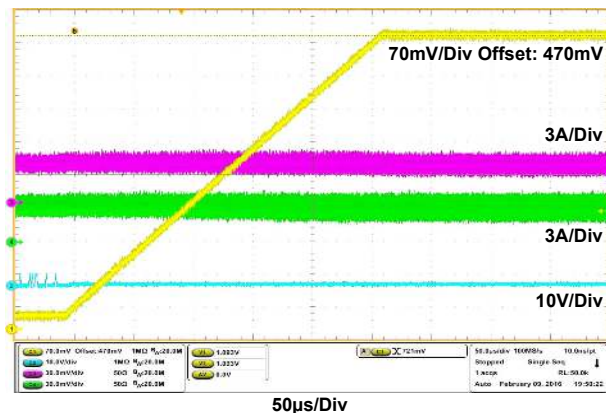

Figure 21. 0.5V to 1.1V DVS, Load = 5A, Slew Rate = 3mV/μs, CH1 - V_{OUT} , CH4 - I_{LX1} , CH3 - I_{LX2} , CH2 - DVS Command

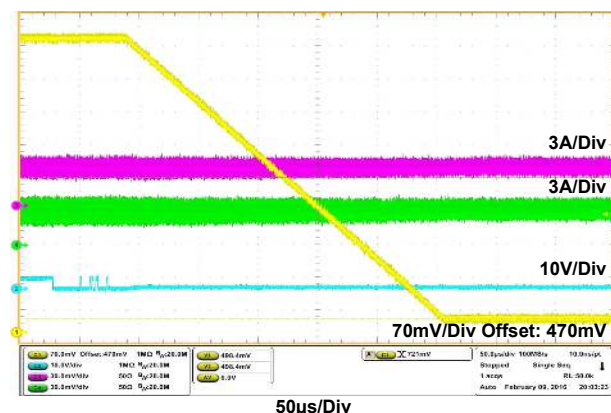

Figure 22. 1.1V to 0.5V DVS, Load = 5A, Slew Rate = 3mV/μs, CH1 - V_{OUT} , CH4 - I_{LX1} , CH3 - I_{LX2} , CH2 - DVS Command

Unless otherwise noted, operating conditions are: $V_{IN} = 3.8V$, $V_{OUT} = 1V$, V_{IO} and Enable = 1.8V, $T_A = +25^\circ C$, $f_{SW} = 4MHz$, 2+1+1 configuration, $L = 220nH$ per phase, SW1: $C_{OUT} = 2 \times 22\mu F + 2 \times 4.3\mu F + 4 \times 1\mu F$, SW2-3: $C_{OUT} = 1 \times 22\mu F + 4 \times 4.3\mu F$. (Continued)

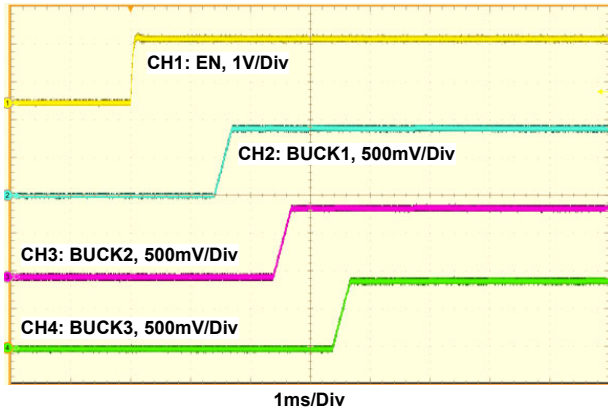

Figure 23. ISL91211A Startup-Up by EN, $V_{OUT1, 2, 3} = 0.9V$

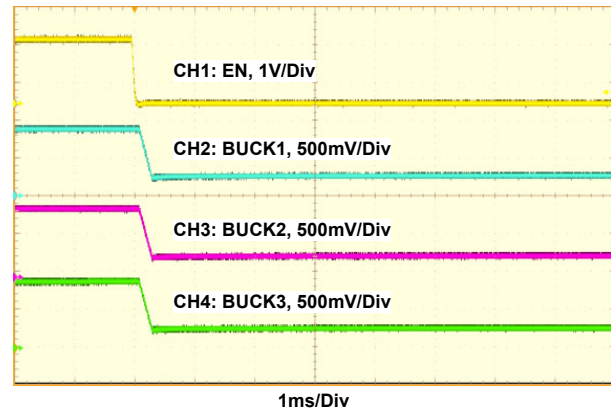

Figure 24. ISL91211A Shutdown by EN, $V_{OUT1, 2, 3} = 0.9V$

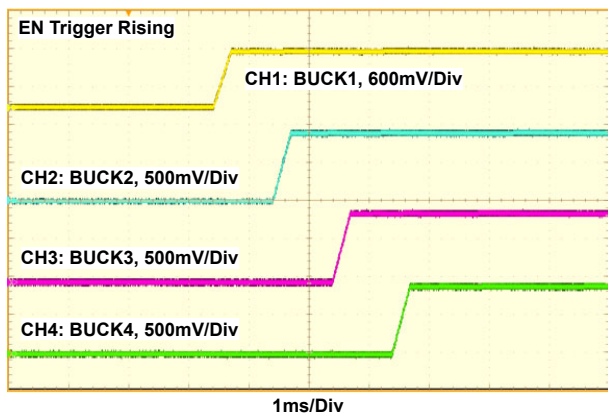

Figure 25. ISL91211B Startup-Up BY EN, $V_{OUT1, 2, 3, 4} = 0.9V$

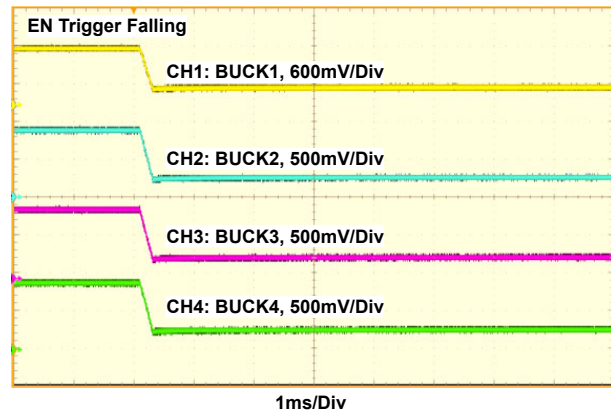

Figure 26. ISL91211B Shutdown by EN, $V_{OUT1, 2, 3, 4} = 0.9V$

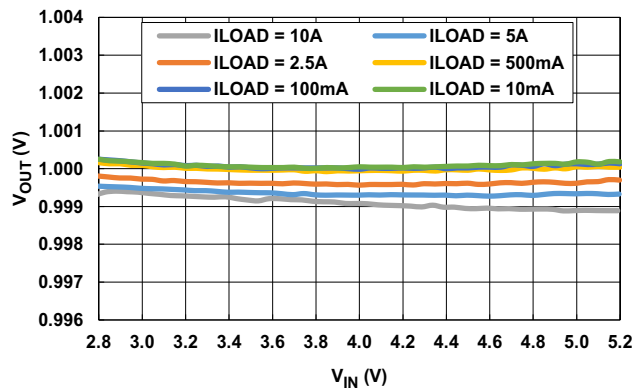

Figure 27. Dual Phase, V_{OUT} vs V_{IN} (10mA to 10A)

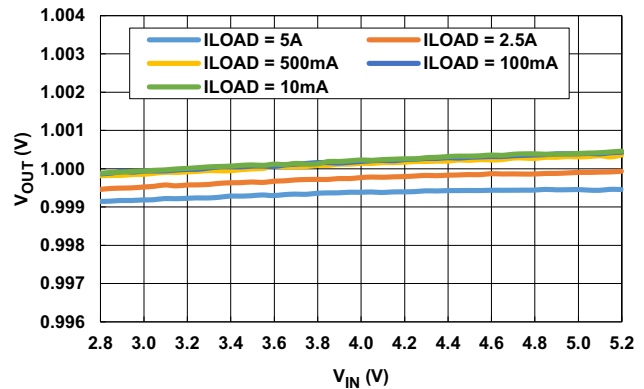

Figure 28. Single Phase, V_{OUT} vs V_{IN} (10mA to 5A)

Unless otherwise noted, operating conditions are: $V_{IN} = 3.8V$, $V_{OUT} = 1V$, V_{IO} and Enable = 1.8V, $T_A = +25^\circ C$, $f_{SW} = 4MHz$, 2+1+1 configuration, $L = 220nH$ per phase, SW1: $C_{OUT} = 2 \times 22\mu F + 2 \times 4.3\mu F + 4 \times 1\mu F$, SW2-3: $C_{OUT} = 1 \times 22\mu F + 4 \times 4.3\mu F$. **(Continued)**

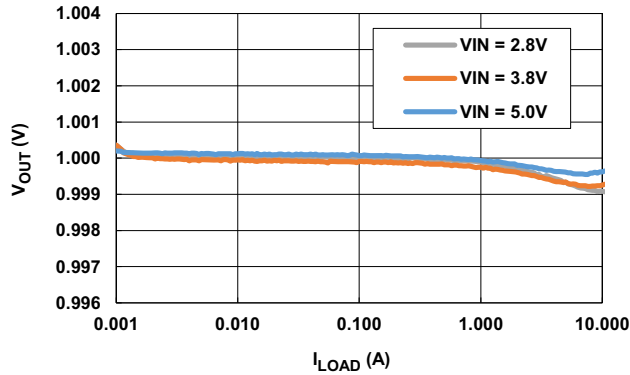

Figure 29. Dual Phase, V_{OUT} vs Load (1mA to 10A)

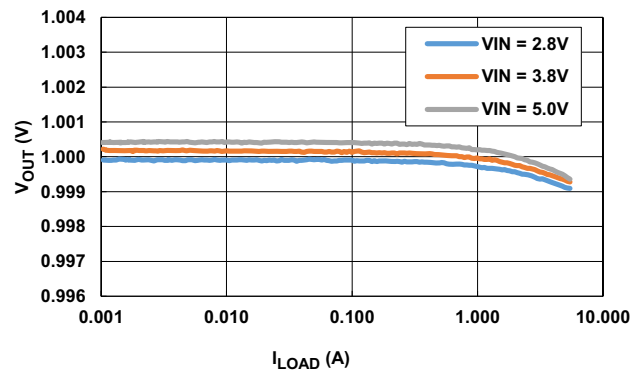

Figure 30. Single Phase, V_{OUT} vs Load (1mA to 5A)

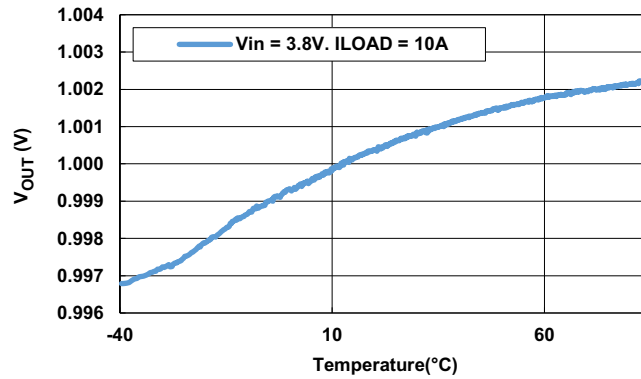

Figure 31. Dual-Phase Forced CCM, V_{OUT} vs Temperature ($-40^\circ C$ to $+85^\circ C$)

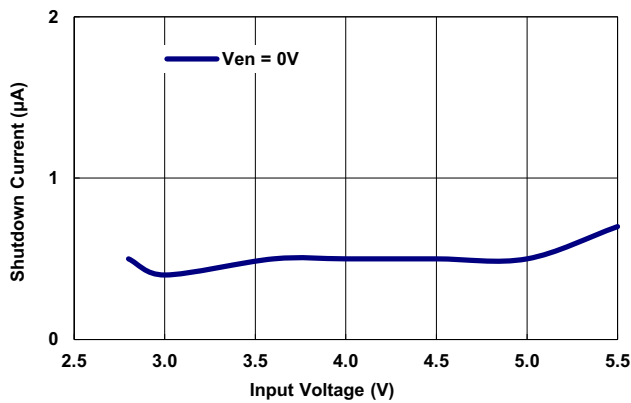

Figure 32. Shutdown Current vs V_{IN}

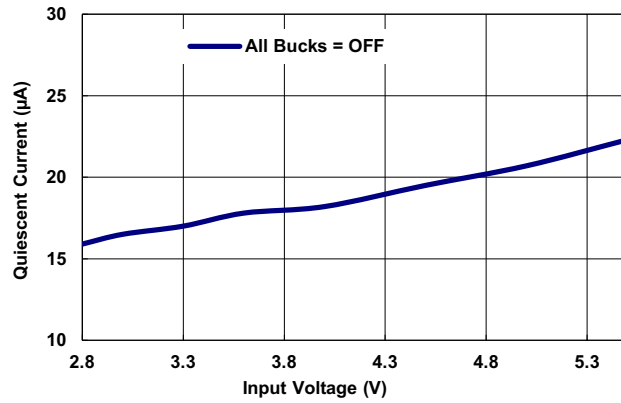

Figure 33. Quiescent Current (All Bucks Off) vs V_{IN}

Unless otherwise noted, operating conditions are: $V_{IN} = 3.8V$, $V_{OUT} = 1V$, V_{IO} and $Enable = 1.8V$, $T_A = +25^{\circ}C$, $f_{SW} = 4MHz$, 2+1+1 configuration, $L = 220nH$ per phase, SW1: $C_{OUT} = 2 \times 22\mu F + 2 \times 4.3\mu F + 4 \times 1\mu F$, SW2-3: $C_{OUT} = 1 \times 22\mu F + 4 \times 4.3\mu F$. **(Continued)**

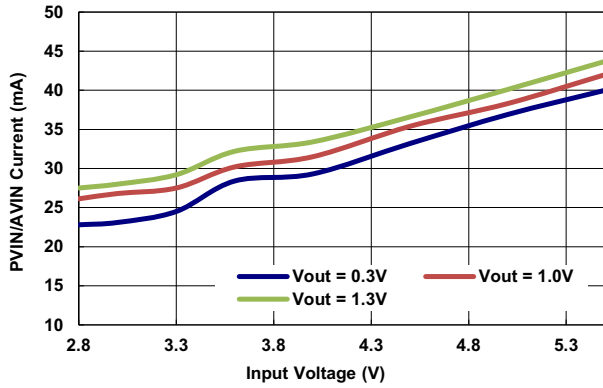

Figure 34. Single-Phase PVIN/AVIN Current (PWM Switching) vs V_{IN}

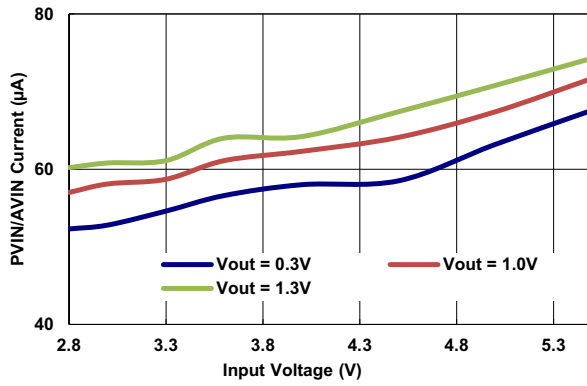

Figure 35. Single-Phase PVIN/AVIN Current (PFM Switching) vs V_{IN}

5. Applications Information

5.1 Inductor Selection

The ISL91211A and ISL91211B are high performance PMICs with integrated synchronous buck converters that can deliver up to 5A of continuous current per phase at 0.3V to 2.0V regulated voltage. The ISL91211B is designed to operate with up to four single phases (1+1+1+1 configuration), and the ISL91211A is designed to work with two single phases and one dual phase (2+1+1 configuration) at an optimized switching frequency of 2MHz ~ 4MHz. Contact [support](#) for questions relating to a switching frequency of 6MHz. In the dual phase configuration, each channel requires an inductor of equal value and should be capable of delivering the maximum load divided by two.

Table 5. Recommended Output Inductors

Manufacturer	Part Number	L x W x H (mm)	VALUE (nH)	DCR mΩ (Typ)	ISAT (Typ)
CYNTEC	HMLB25201T	2.5x2.0x1.0	220	9.4	7.0
TAIYO YUDEN	MAKK2520HR22M	2.5x2.0x1.0	220	16	8.5
CYNTEC	HTTN2016T	2.0x1.6x1.0	220	13	7.2
MURATA	DFE2016E	2.0x1.6x1.0	240	16	7.0
MURATA	DFE252012F	2.5x2.0x1.2	470	23	6.7
COILCRAFT	XEL4020-561ME	4.0x4.0x2.0	560	8	11.3

5.2 Output Capacitor Selection

Output capacitors are needed to provide filtering of the switching voltage at the phase node into a regulated output voltage. The amount of output capacitance required is based on parameters of maximum load step, the slew rate of the load step, as well as the maximum allowable voltage regulation tolerance during the transient. The amount of ripple voltage at the output capacitor is also a design constraint, the total peak-to-peak ripple voltages produced from the output capacitor is equal to its ESR, multiplied by the worst case inductor ripple current.

Use ceramic capacitors due to their low ESR and ESL properties. Make sure to select X7R or X5R type capacitors and take into consideration for DC bias effects. A wide range of output capacitor values may be used.

Table 6. Recommended Output Capacitors

Manufacturer	Part Number	Case Size	Value (μF)	Voltage (V)
TDK	C1608X5R1A226M080AC	0603	22	10
TDK	C0510X6S0G105M030AC	0204	1	4
MURATA	LLD154R60G435ME01	0402	4.3	4
MURATA	LLL1U4R60G435ME22	0204	4.3	4

5.3 Input Capacitor Selection

Ceramic input capacitors are responsible for sourcing the AC component of the input current flowing into the high-side MOSFETs. They need to be placed as close to the IC as possible. A 10 μ F local decoupling capacitor is recommended for each phase PVIN. If long wires are used to bring power to the IC, use additional “bulk” capacitors between C_{IN} and the battery/power supply to dampen ringing and overshoot at start-up.

Internal analog reference circuits also require additional filtering at the AVIN_FILT pin.

Table 7. Recommended Input Capacitors

Mfr	Part Number	Case Size	Value (μ F)	Volt (V)	Input
TDK Corp	CGB2A1X5R1A105M033BC	0402	1	10	AVIN_FILT
Kemet	C0402C104K8RACTU	0402	0.1	10	AVIN_FILT
Samsung	CL05A10MP5NUNC	0402	10	10	PVIN

5.4 Dynamic Voltage Scaling (DVS)

The ISL91211A and ISL91211B has several options to achieve Dynamic Voltage Scaling (DVS). Each buck controller has four independently programmable voltage settings that can set the output voltage. The settings are DVS0, DVS1, DVS2, and DVS3. By changing the DVS number selected, the corresponding output voltage is selected. The two methods to select the DVS are:

- **Method 1)** Use internal registers to select DVS by writing to the BUCKx_DVSSELECT[1:0] bits in the BUCKx_DVSSEL register for each respective buck using SPI or I²C.

To use this method, the BUCKx_DVSCTRL[0] bit has to be set to “0x0” for the corresponding buck. The BUCKx_DVSSELECT[1:0] setting allows you to switch between the four different DVS settings, each of which corresponds to a set of DVS registers holding the DVS information.

For example, DVS0 corresponds to BUCKx_DVS0VOUT92[7:0] and BUCKx_DVS0VOUT10[1:0]. The two register values combined represent the complete 10-bit DAC code for DVS0.

Table 8. DVS Method Selection

BUCKx_DVSCTRL[0]	
0x0	Use BUCKx_DVSSELECT[1:0] to select active DVS configuration
0x1	Use DVS pin(s) to control DVS selection

Table 9. DVS Pointers

BUCKx_DVSSELECT[1:0]	Active DVS for BUCKx
0x0	DVS0
0x1	DVS1
0x2	DVS2
0x3	DVS3

Each output voltage is set writing a 10-bit word to DVS Configuration 1 (BUCKx_DVS0CFG1 register) and DVS Configuration 0 (BUCKx_DVS0CFG0 register) in each buck. Configuration 1 holds the most significant eight bits and Configuration 0 holds the last two bits of the 10-bit word. The output voltage does not change until the LSB register has been written. Table 10 on page 23 shows the relationship between the DVS word and VOUT.

Table 10. 10-Bit DVS Code to Voltage Translation

FBDIV	1.0	0.8	0.6
DAC [9:0]	V _{OUT} (V)	V _{OUT} (V)	V _{OUT} (V)
0x000	0.0000	0.0000	0.0000
0x001	0.0012	0.0015	0.0020
...			
0x200	0.6173	0.7716	1.0288
0x201	0.6185	0.7731	1.0308
...			
0x3E5	1.199	1.4988	1.9983

- **Method 2)** - Use the GPIO/MPIO pins to configure DVS. There are five variations depending on the IO_PINMODE register setting. See [Table 2 on page 9](#) for information about the variations.

Note: To use DVS with the GPIO/MPIO pins, IO_PINMODE must be OTP programmed before a startup boot sequence is initiated. On-the-fly programming is not recommended for the following configurations.

(i) IO_PINMODE = 0x3: SPI with multiple buck DVS pins.

MPIO0	MPIO1	MPIO2	MPIO3	GPIO0	GPIO1	GPIO2
SCK	SS_B	MOSI	MISO	DVS_A	DVS_B	DVS_C

BUCK_x_DVSPIN_CFG[1:0] bits in BUCK_x_SHUTDN_DLY registers maps the particular buck DVS to DVS_x GPIO pin. Same pin can be used to control DVS for all buck controllers. See [Table 11](#) for more information. BUCK_x_DVSCTRL[0] should be OTP programmed high before the startup sequence. The active DVS follows the DVS_x pin logic for the respective buck. See [Table 11](#) for more information.

Table 11.

BUCK _x _DVSPIN_CFG[1:0]	Function	
0x0	DVS_A pin	Active DVS for BUCK _x
	0	DVS0
	1	DVS1
0x1	DVS_B pin	Active DVS for BUCK _x
	0	DVS0
	1	DVS1
0x2	DVS_C pin	Active DVS for BUCK _x
	0	DVS0
	1	DVS1
0x3	BUCK _x DVS0 pointer follows I2C/SPI programmed register setting.	

(ii) IO_PINMODE = 0x4: I²C with Global DVS and PGOOD pins

MPIO0	MPIO1	MPIO2	MPIO3	GPIO0	GPIO1
DVS_PIN1	DVS_PIN0	PGOOD1	PGOOD2	I2C_CLK	I2C_SDA

The BUCKx_DVSPIN_CTRL[1:0] bits in the BUCKx_DVSCFG register in combination with the DVS_PIN1 and DVS_PIN2 set the active DVS for the respective BUCK. See [Table 12](#) for more information. BUCKx_DVSCTRL[0] should be OTP programmed high before the startup sequence.

Table 12. Global DVS Pin Logic

BUCKx_DVSPIN_CTRL[1:0]	DVS_PIN1	DVS_PIN0	Active DVS
0x0	X	X	DVS0
0x1	X	0	DVS0
	X	1	DVS1
0x2	0	X	DVS0
	1	X	DVS2
0x3	0	0	DVS0
	0	1	DVS1
	1	0	DVS2
	1	1	DVS3

Note: The 'X' in indicates that either a 0 or 1 is acceptable.

(iii) IO_PINMODE = 0x5: I²C with 2 DVS pins for Buck1 and 2 DVS pins for Buck2

MPIO0	MPIO1	MPIO2	MPIO3	GPIO0	GPIO1
BUCK1_DVS0	BUCK1_DVS1	BUCK2_DVS0	BUCK2_DVS1	I2C_CLK	I2C_SDA

The active DVS is selected based on the combined BUCKx_DVS0 and BUCKx_DVS1 input pin logic. See [Table 13](#) for more information. BUCKx_DVSCTRL[0] should be OTP programmed high before the startup sequence.

Table 13. Active DVS for 2 DVS Pins Configuration

BUCKx_DVS1	BUCKx_DVS0	Active DVS for BUCKx
0	0	DVS0
0	1	DVS1
1	0	DVS2
1	1	DVS3

(iv) IO_PINMODE = 0x6: I²C with full 2 pin DVS control for Buck1 and 1 pin DVS control for Buck2 and Buck3.

MPIO0	MPIO1	MPIO2	MPIO3	GPIO0	GPIO1
BUCK1_DVS0	BUCK1_DVS1	BUCK2_DVS0	BUCK3_DVS0	I2C_CLK	I2C_SDA

BUCKx_DVSCTRL[0] should be OTP programmed high before the startup sequence. BUCK1_DVS0 and BUCK1_DVS0 follow the same active DVS table as in IO_PINMODE = 0x5. See [Table 13](#) for more information.

Table 14. Active DVS for 1 DVS pin configuration

BUCKx_DVS1	BUCKx_DVS0	Active DVS for BUCKx
0	0	DVS0
0	1	DVS1

(v) IO_PINMODE = 0x7: I²C with 1 pin DVS control for each buck.

MPIO0	MPIO1	MPIO2	MPIO3	GPIO0	GPIO1
BUCK1_DVS0	BUCK2_DVS0	BUCK3_DVS0	BUCK4_DVS0	I2C_CLK	I2C_SDA

BUCKx_DVSCTRL[0] should be OTP programmed high before the startup sequence. BUCKx_DVS0 follows the same active DVS table for 1 DVS pin configuration as in IO_PINMODE = 0x6. See [Table 14 on page 24](#) for more information.

5.5 Configuring DVS Speed

5.5.1 Power-Up and Shutdown Slew Rate Setting

The BUCKx_RSPPUP[2:0] bits in the BUCKx_RSPCFG0 register set the slew rates (DVS speed) in BUCKx only during V_{OUTx} power-up. Similarly, the BUCKx_RSPPDN[2:0] bits in the BUCKx_RSPCFG0 register set the slew rates in BUCKx during normal V_{OUTx} shutdown. The achievable slew rates vary with different FBDIV settings (factory OTP programmed). For more details, see Register [“BUCK1_RSPCFG0” on page 49](#).

5.5.2 DVS Transition Slew Rate Setting

The BUCKx_RSPUP[2:0] and BUCKx_RSPDN[2:0] bits in the BUCKx_RSPCFG1 register set the slew rates (DVS speed) in BUCKx during normal DVS transition. The achievable slew rates vary with different FBDIV settings (factory OTP programmed). For more details, see Register [“BUCK1_RSPCFG1” on page 48](#).

5.6 Output Voltage Setting

Each output voltage is set by writing a 10-bit word to DVS Configuration 1 (BUCKx_DVS0CFG1 register) and DVS Configuration 0 (BUCKx_DVS0CFG0 register) in each buck. Configuration 1 holds the MSB and Configuration 0 holds the last two bits of the 10-bit word. The output voltage does not change until the LSB register is written. [“BUCK1_DVS0CFG1” on page 46](#) shows the relationship between the DVS word and V_{OUT}.

5.7 Power Sequencing

When the master chip Enable (EN) pin is brought above an NMOS threshold, the ISL91211A and ISL91211B powers up its key biasing circuits, loads the OTP configuration registers, and performs one of the following actions based on the preprogrammed OTP setting:

- **Manual buck start-up:**

Program the internal IO_BUCKx_EN bits to “1” from I²C/SPI to enable the respective buck. When IO_PINMODE = 0x1, the EN_A, EN_B and EN_C pins can also be used to enable the respective bucks. If using this pin mode, the internal IO_BUCKx_EN bits should be set high in OTP. The slew rate of each buck during its soft-start is specified by the BUCKx_RSPPUP[2:0] bits.

Note: The programmable delay (0ms to 63ms) using BUCKx_EN_DLY[5:0] is not used for Manual Buck startup.

- **Auto buck start-up from master chip enable pin:**

Run a predetermined startup sequence for the buck outputs as soon as BOOT is complete. The slew rate of each buck during its soft-start is specified in BUCKx_RSPPUP[2:0].

[Figure 36 on page 26](#) provides an example of power-up configurability. The master chip enable pin (EN) transitions from 0 to 1 and OTP is loaded over 1.4ms. After the initial 1.4ms boot interval, the buck output start-up sequence begins. In the [Figure 36](#) example, BUCK1_EN_DLY is set for 0ms, BUCK2_EN_DLY is set for 1ms, BUCK3_EN_DLY is set for 2ms, and BUCK4_EN_DLY is set for 3ms.

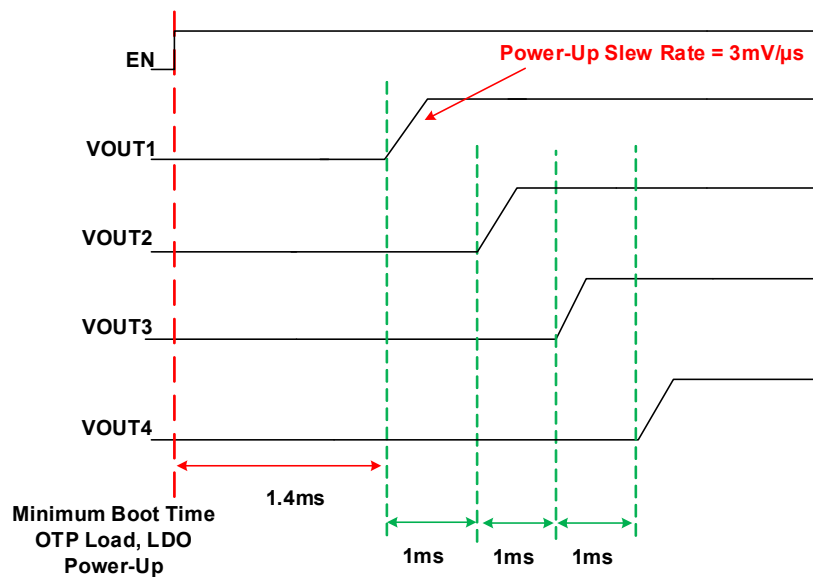

Figure 36. Master Chip Enable Power-Up Example

The buck outputs can also be programmed to execute a controlled shutdown in two ways:

- **Manual buck power-down:**

Program the internal IO_BUCKx_EN bit to “0” through I²C/SPI or lower the Buck Enable pin (EN_A, EN_B and EN_C when IO_PINMODE = 0x1). The manual method can be used to power down a specific buck (with a controlled slew rate) while keeping the rest of the chip alive.

Note: The programmable (0ms to 63ms) delay from BUCKx_SHUTDOWN_DLY[5:0] is not used for manual buck power-down.

- **Auto Buck power-down from master chip enable pin:**

When the master chip Enable pin (EN) is brought below the falling threshold of the comparator, the Bucks are ramped down at a controlled rate using preprogrammed delays. The bias circuits then power down, forcing the chip into shutdown. The slew rate of each buck during its power-down (down to ~250mV) is specified in BUCKx_RSPPDN[2:0].

Figure 37 provides an example of power-down configurability. The master chip enable pin (EN) transitions from logic 1 to 0. In the Figure 37 example, BUCK1_SHUTDOWN_DLY is set for 1ms, BUCK2_SHUTDOWN_DLY is set for 1ms, BUCK3_SHUTDOWN_DLY is set for 1ms, and BUCK4_SHUTDOWN_DLY is set for 1ms.

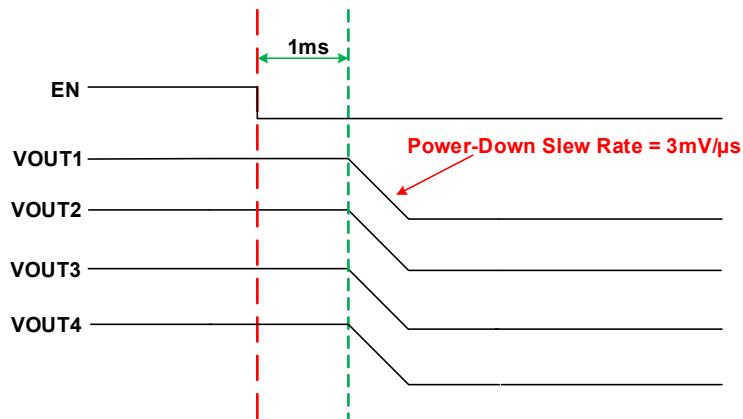

Figure 37. Auto Chip Power-Down Example

The actual slew rate that each buck ramps down to is specified by the register “BUCKx_RSPPDN”. The default slew rate for each buck discharging during power-down sequence is 3mV/μs. This slew rate is controlled until the output voltage is ~250mV. Below 250mV, there are two output voltage decay options:

- **Option 1:** If the disable event for a buck output is the master chip enable pin (EN) falling below its logic low threshold, then when the output falls below 250mV, the output voltage decay is dictated by the system load passively discharging the buck output capacitance. PULL_DOWN_DISCHARGE bit per the BUCK2_CFG2 register is **not** used in this method.
- **Option 2:** If the disable event for a buck output is the master chip enable pin (EN) remaining high and the enable register bit (IO_BUCKx_EN) transitioning from a logic 1 to a logic 0, then PULL_DOWN_DISCHARGE bit per the BUCK2_CFG2 register is used enabling an internal weak pull down.

Note: The weak pull-down can be disabled (using factory OTP).

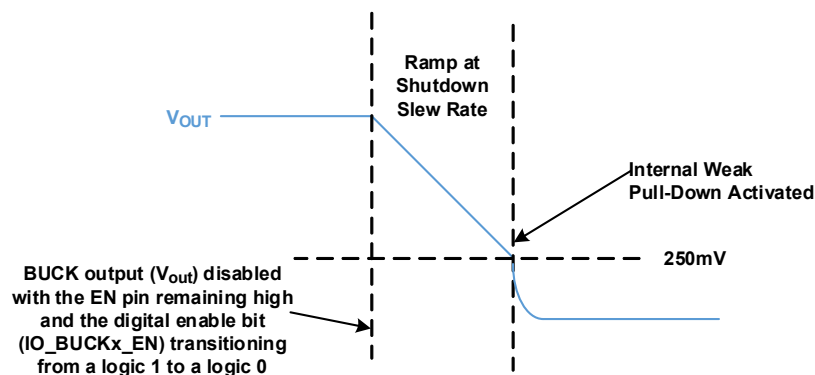

Figure 38. Buck Disable Waveform

5.8 Watchdog Time (WDOG_RST Pin)

The ISL91211A and ISL91211B implement a watchdog function that allows the output voltages to return to a safe OTP default when communication to the processor host is lost. This is determined by monitoring the state of the WDOG_RST pin. If the pin goes low for greater than $t_{DEBOUNCE}$, the default voltages from OTP are restored.

All four buck(s) respond to the WDOG_RST Pin. The polarity of the WDOG_RST pin is programmable to active low.

Table 15. WDOG_RST Function

Action	
At Boot Up	DVS registers are loaded with values stored in OTP
After Debounce Time	Restore selected output voltages to their original values stored in OTP (DVS0), and slew the buck outputs to that voltage

Total recovery time for the buck is the sum of the t_{SLEW} and $t_{DEBOUNCE}$. WDOG_RST pin resets ISL91211A and ISL91211B buck outputs to the target voltage set by DVS0, which resides in the BUCKx_DVS0CFG1 and BUCKx_DVS0CFG0 registers.

t_{SLEW} is determined by the default output voltage divided by 3mV/μs, while $t_{DEBOUNCE}$ is set at 10ms.

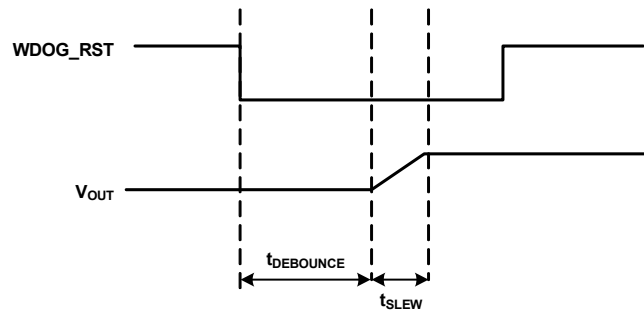

Figure 39. Watchdog Timer Example Case

5.9 Interrupt Pin

The ISL91211A and ISL91211B can alert the host when a warning or a fault has occurred through an IRQ interrupt request signal with configurable masking options that is connected to a configurable interrupt (INT) pin. The interrupt pin can be programmed to be active high, active low, an open drain, or a CMOS output.

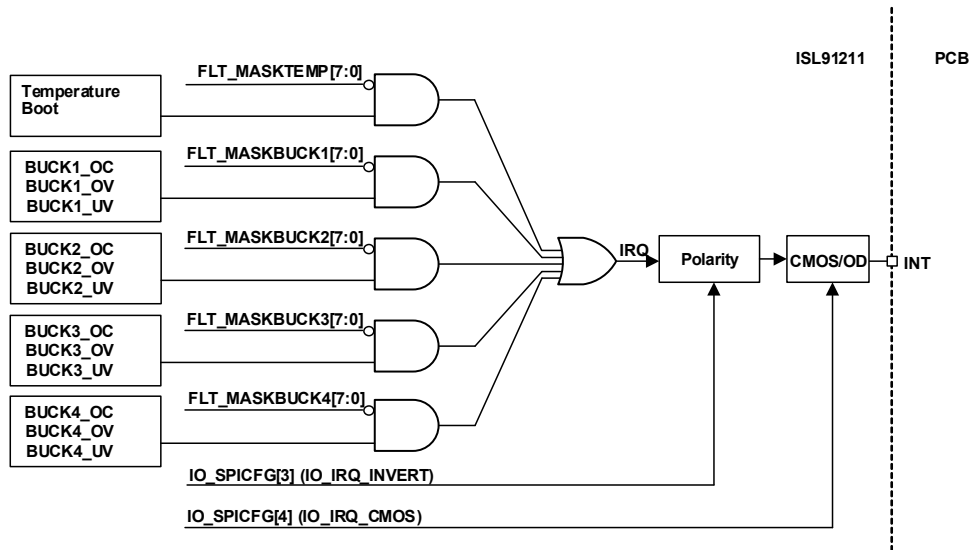

Figure 40. Interrupt Tree

6. Protection Features (FAULTS)

The ISL91211A and ISL91211B have overcurrent, overvoltage, undervoltage, and over-temperature protection features.

6.1 Over-Temperature Protection

The ISL91211A and ISL91211B provide protection against over-temperature conditions. The over-temperature protection circuit continuously monitors the chip's die temperature and raises a fault when the temperature exceeds +150°C. When the over-temperature fault occurs, all the buck converters, by default, shutdown and then are re-enabled when the OT fault deasserts. Hysteresis enables the circuit to clear the fault when the temperature is below a predefined safe temperature. Hysteresis is hard coded as the difference between +95°C and +150°C.

6.2 Overcurrent Protection Mode

The overcurrent protection block has a current comparator that compares the load current through the high-side power FET with the reference current level through a replica device. After RC delay filtering and/or cycle detection filtering, the output of the overcurrent protection block goes to the fault detection block, which makes the decision to disable the buck and latch the power-stage into high impedance mode. The digital core periodically re-enables the buck to detect if the fault has cleared.

6.3 Overvoltage (OV)/Undervoltage (UV) Protection

The ISL91211A and ISL91211B protect against output overvoltage and undervoltage fault conditions. The OV/UV protection circuitry has low power comparators configured with differential input and single-ended outputs capable of working over a large common-mode input range. This comparator is used to monitor the output voltage in both DCM and CCM for faults.

By default, when an OV is triggered, the buck converter crowbars the output by turning on the low-side NMOS for a duration of 32µs to 64µs. After that the buck shuts down and exits crowbar. The buck tries to start up and if the fault condition still exists, the buck reacts to OV again until the fault is removed. When an UV event is triggered, the buck converter shuts down and restarts up until the fault is cleared. The UV/OV threshold is a configurable window around the V_{OUT} DAC target. The default setting is ±250mV.

7. Serial Communication Interface

ISL91211A and ISL91211B have two serial interface protocols to read/write the registers.

- SPI
- I²C

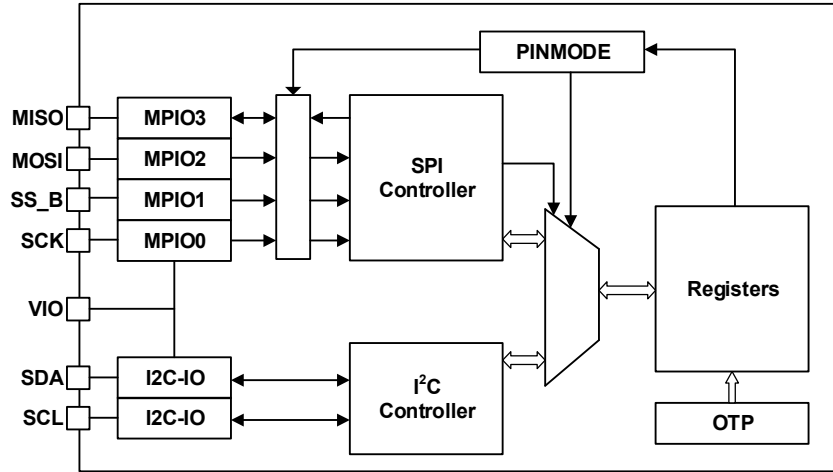

Figure 41. SPI/I²C Interface

The arbitration of the register access bus (between SPI and I²C) is determined by the register IO_PINMODE and the MPIO1 pin as shown in [Table 16](#):

Table 16. SPI/I²C Register Access

Register IO_PINMODE	MPIO_1 Pin (SS_B)	Register Access
0	0	SPI (Read/Write Access (Note 10))
	1	I ² C (Note 11)

Notes:

10. When the device is configured for SPI access, I²C should not be addressed with the device ID.
11. When the device is configured for I²C access, in PINMODE 0, SS_B line must be held high.

After switching from SPI to I²C or vice versa, there is a minimum of 50ns wait time required before starting a transaction.

7.1 The SPI Interface

The SPI interface is a general spec 4-wire slave interface capable of operating at a clock speed of up to 26MHz. It is based on byte transfers.

7.1.1 SPI Data Protocol

Both Read and Write SPI transactions begin when SS_B goes low and end when SS_B goes high.

Write Operation: To write to ISL91211A and ISL91211B, the master (controller) needs to drive SS_B low and then send the Control Byte, followed by register address, packet length (if IO_SPIMODE = 1), Data bytes to be written, and finally drive SS_B high to terminate the transaction as shown below. The MSB of the Control byte is the R/W bit, which needs to be set to ‘write’ operation (see IO_SPIWPOL). Bit 6, AI indicates if it is going to be a single byte write operation or a multibyte write. Bits 1 and 0 of the Control byte, indicate the page number of the register location desired to be written (MSBs of the register address). The register address byte is the 8-bit address of the register within the page specified by Page[1:0] bits. If IO_SPIMODE = 1, the register address needs to be followed by 8-bit packet length, which indicates the number of bytes to be written. Following the packet length field, the master needs to send the data bytes. When all eight bits of data are received, they get written to the specified register address and ISL91211A and ISL91211B increment the register address. If it is a single byte transaction, (AI = 0 or Packet length = 1), then ISL91211A and ISL91211B go into wait state and wait for SS_B to go high. If it is a multibyte transaction with IO_SPIMODE = 1, then ISL91211A and ISL91211B write the subsequently received data bytes to sequentially incrementing addresses until the number of bytes, as specified by ‘packet length’, are received and then go into wait state and wait for SS_B to go high. For multibyte transactions with IO_SPIMODE = 0 and AI = 1, ISL91211A and ISL91211B keep writing the subsequently received data bytes to sequentially incrementing addresses until SS_B goes high. If SS_B goes high in the middle of a transaction, the transaction is terminated. All the data bytes, whose all eight bits are received, get written.

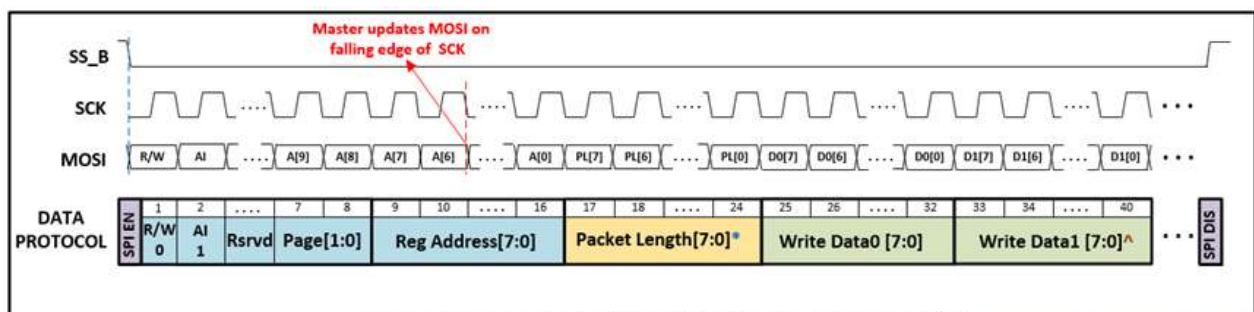

* Only present when IO_SPIMODE = 1

^ Only present for Multi Word Transactions

Figure 42. SPI Write Transaction with IO_SPIMODE = 1; IO_SPICPOL = 0; IO_SPICPHA = 0

Read Operation: To read from ISL91211A and ISL91211B, the master (controller) needs to drive SS_B low and then send the Control Byte, followed by register address, packet length (if IO_SPIMODE = 1). The ISL91211A and ISL91211B then send the data bytes from the requested registers and finally the master drives SS_B high to terminate the transaction. The MSB of the Control byte is the R/W bit that needs to be set to ‘read’ operation (see IO_SPIWPOL). Bit 6, AI indicate if it is going to be a single byte read operation or a multibyte read. Bits 1 and 0 of the Control byte indicate the page number of the register location desired to be read (MSBs of the register address). Register address byte is the 8-bit address of the register within the page specified by Page[1:0] bits. If IO_SPIMODE = 1, the register address needs to be followed by an 8-bit packet length, which indicates the number of bytes to be written. Following the packet length field, ISL91211A and ISL91211B send the data from the requested register. When all eight bits of data from the requested register address are sent, ISL91211A and ISL91211B increment the register address. If it is a single byte transaction, (AI = 0 or Packet length = 1), then ISL91211A and ISL91211B go into wait state and wait for SS_B to go high. If it’s a multibyte transaction with IO_SPIMODE = 1, then ISL91211A and ISL91211B send the data bytes from sequentially incrementing addresses until the number of bytes as specified by ‘packet length’ are sent and then go into wait state and wait for SS_B to go high. For multibyte transactions with IO_SPIMODE = 0 and AI = 1, ISL91211A and ISL91211B keep sending data bytes from sequentially incrementing addresses until SS_B goes high. **Note:** The MISO pin is pulled low while SS_B is high.

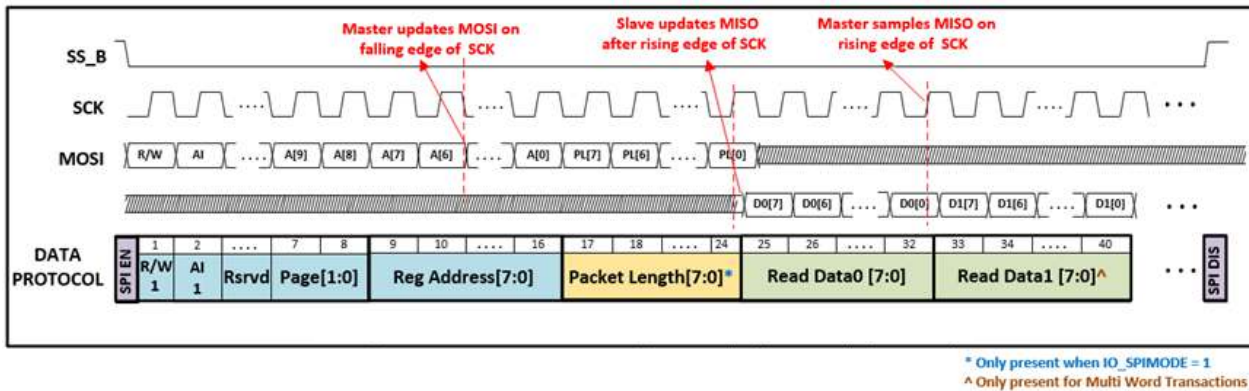

Figure 43. SPI Read Transaction with IO_SPIMODE = 1; IO_SPICPOL = 0; IO_SPCPHA = 0

R/W	Read/Write Bit Indicating Read or Write Operation
AI	Auto Increment. 1 indicates multi byte transfer, 0 indicates single byte transfer
Page	2-bit page address of the register to be written/read.
Address	8-bit register address of the register to be written/read
Packet Length	8-bit packet length indicating number of data bytes to be transferred. Overrides AI when IO_SPIMODE = 1
Read Datan	Data in the register at address, Address [7:0] + n
Write Datan	Data to be written to the register at address, Address [7:0] + n

7.1.2 SPI Configuration

The following register bits configure the SPI operation:

- IO_SPICPOL: SPI clock polarity, ISL91211A and ISL91211B are configured as active high, IO_SPICPOL = 0
- IO_SPCPHA: SPI clock phase, ISL91211A and ISL91211B sample data on rising edge of SPI clock, IO_SPCPHA = 0

The four possible modes of clocking are shown in [Figure 44](#).

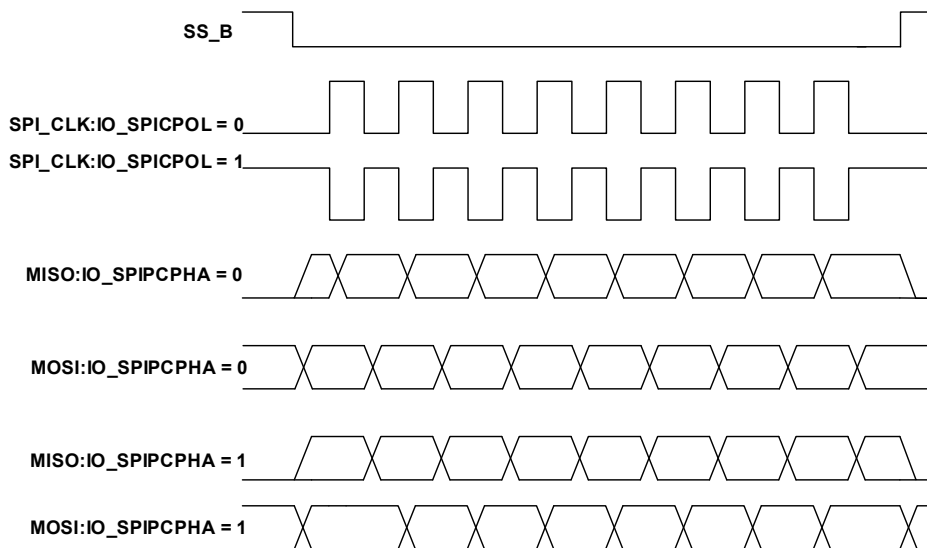

Figure 44. Four Possible Clocking Modes

- **IO_SPIWPOL**: R/W bit polarity, ISL91211A and ISL91211B SPI_RWPOL is set to 0, 1: Read, 0: Write.

SPI_RWPOL	R/W	Operation
0	0	Write
0	1	Read

- **IO_SPIMODE**: Packet length enable, ISL91211A and ISL91211B use packet length mode by default, meaning the third data byte from master is the packet length and indicates the total number of data words to be sent/received in a burst transaction.

7.1.3 SPI Timing

Figure 45 shows SPI timing for IO_SPICPOL = 0; IO_SPICPHA = 0. The timing values in Table 17 hold true for other values of IO_SPICPOL, IO_SPICPHA as well.

Table 17. Timing Values

Parameter	Symbol	Min	Typ	Max	Unit
Clock Period	t_1	38.4			ns
Enable Lead Time	t_2	12			ns
Enable Lag Time	t_3	12			ns
Clock High or Low Time	t_4	15			ns
Data Setup Time (Input)	t_5	12			ns
Data Hold Time (Input)	t_6	10			ns
Time MISO is Stable before the Next Rising Edge of CLK	t_7	5			ns
Data Held after Clock Edge (Output)	t_8	5			ns
Load Capacitance	CL			10	pF

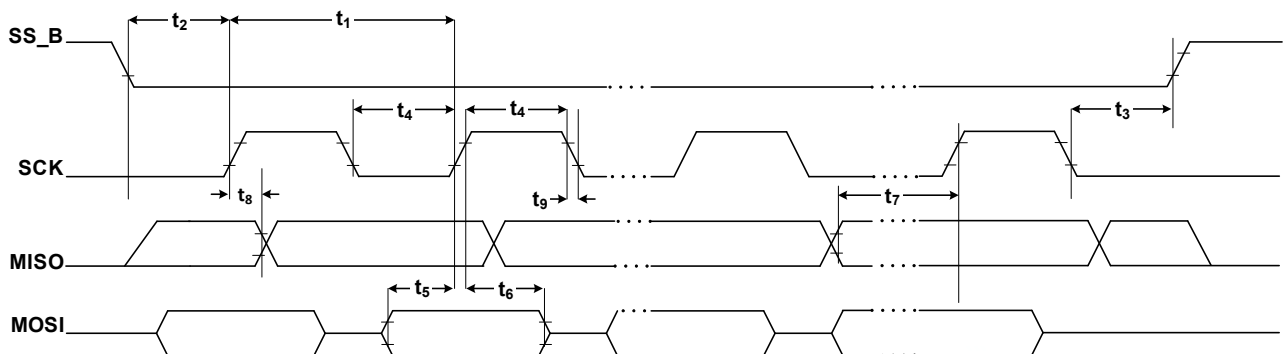

Figure 45. SPI Timing for IO_SPICPHA = 0, IO_SPICPOL = 0

7.2 The I²C Interface

I²C interface is a simple, bidirectional 2-wire bus protocol, consisting of serial clock control (SCL/I²C_CLK) and serial data signal (SDA/I²C_SDA). ISL91211A and ISL91211B host a slave I²C interface that supports data speeds up to 3.4Mbps. SCL is an input to ISL91211A and ISL91211B and is supplied by the controller, whereas SDA is bidirectional. ISL91211A and ISL91211B have an open-drain output to transmit data on SDA. An external pull-up resistor must be placed on the serial data line to pull the drain output high during data transmission.

ISL91211A and ISL91211B use a 7-bit hardware address scheme. The default address is set to 0x1E by a onetime programmable fuse.

7.2.1 I²C Bus Operation

The chip supports 7-bit addressing. The ISL91211A and ISL91211B I²C device address is reconfigurable through the OTP.

All communication over the I²C interface is conducted by sending the MSB of each byte of data first. Data states on the SDA line can change only during SCL LOW periods. SDA state changes during SCL HIGH are reserved for indicating START and STOP conditions (see [Figure 50 on page 35](#)).

All I²C interface operations must begin with a START condition, which is a HIGH-to-LOW transition of SDA while SCL is HIGH. The ISL91211A and ISL91211B continuously monitor the SDA and SCL lines for the START condition and do not respond to any command until this condition is met. All I²C interface operations must be terminated by a STOP condition, which is a LOW-to-HIGH transition of SDA while SCL is HIGH.

An ACK, Acknowledge, is a software convention used to indicate a successful data transfer. The transmitting device, either master or slave, releases the SDA bus after transmitting eight bits. During the ninth clock cycle, the receiver pulls the SDA line LOW to acknowledge the reception of the eight bits of data ([Figure 50 on page 35](#)). The ISL91211A and ISL91211B respond with an ACK after recognition of a START condition, followed by a valid Identification (a.k.a. I²C Address) Byte. The ISL91211A and ISL91211B also respond with an ACK after receiving a Data Byte of a write operation. The master must respond with an ACK after receiving a Data Byte of a read operation.

Write Operation: A Write operation requires a START condition, followed by an ISL91211A and ISL91211B I²C Address byte with the R/W bit set to 0, a Register Address Byte, Data Bytes, and a STOP condition. After each byte, the ISL91211A and ISL91211B respond with an ACK. After every data byte ISL91211A and ISL91211B auto increment the register address so subsequent data bytes get written to sequentially incremental register locations. A STOP condition that terminates the write operation, must be sent by the master after sending at least one full data byte and its associated ACK signal. If a STOP byte is issued in the middle of a data byte, then the write is not performed.

Read Operation: A Read operation consists of a three-byte “dummy write” instruction to send the register address to begin reading from, followed by a Current Address Read operation. The master initiates the operation, issuing the following sequence: a START condition, followed by an ISL91211A and ISL91211B I²C Address byte with the R/W bit set to “0”, a Register Address Byte, a second START, and a second ISL91211A and ISL91211B I²C Address byte with the R/W bit set to “1”. After each of the three bytes, the ISL91211A and ISL91211B respond with an ACK. The ISL91211A and ISL91211B then transmit Data Bytes. The master terminates the Read operation from the ISL91211A and ISL91211B by issuing a STOP condition following the last bit of the last data byte. After every data byte, ISL91211A and ISL91211B auto increment the register address so subsequent data bytes are sent from sequentially incremental register locations.

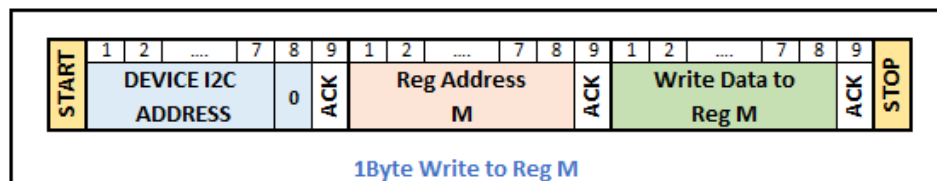

Figure 46. 1-Byte Write to Register M

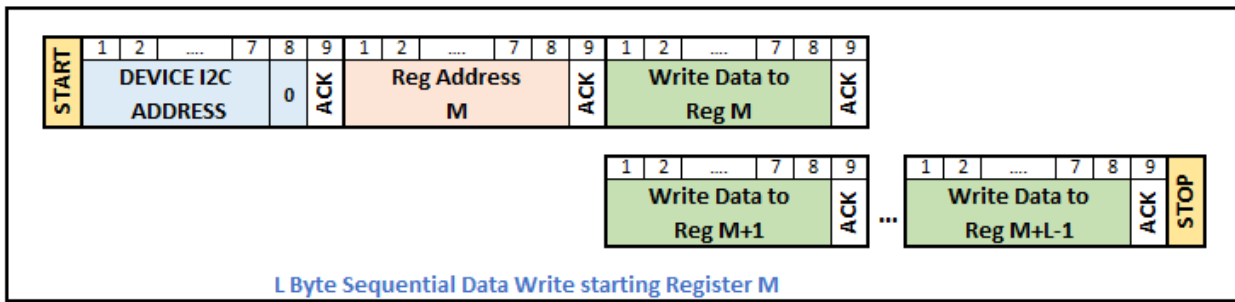

Figure 47. L-Byte Sequential Data Write Starting Register M

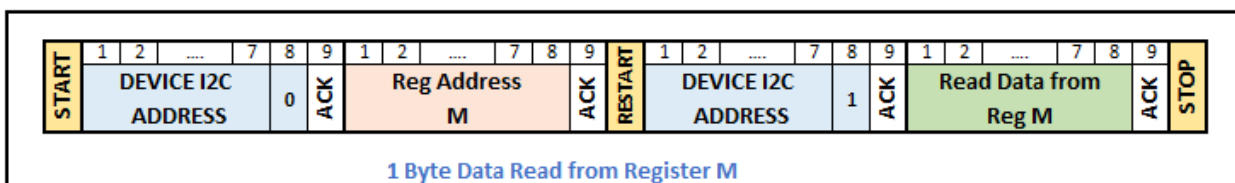

Figure 48. 1-Byte Data Read From Register M

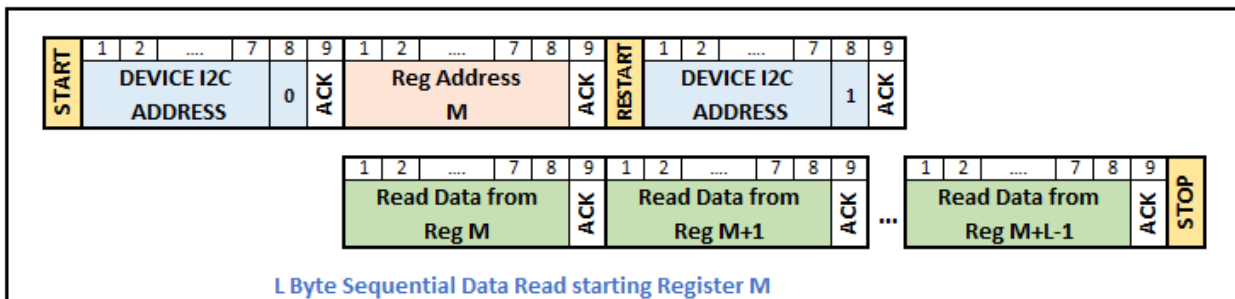

Figure 49. L-Byte Sequential Data Read Starting Register M

7.2.2 I²C Timing

The timing specifications of the I²C I/O from the I²C spec are shown in [Figure 50](#) and [Table 18](#) below. The I²C controller provides a slave I²C transceiver capable of interpreting I²C protocol in Standard, Fast, Fast+, and High Speed modes.

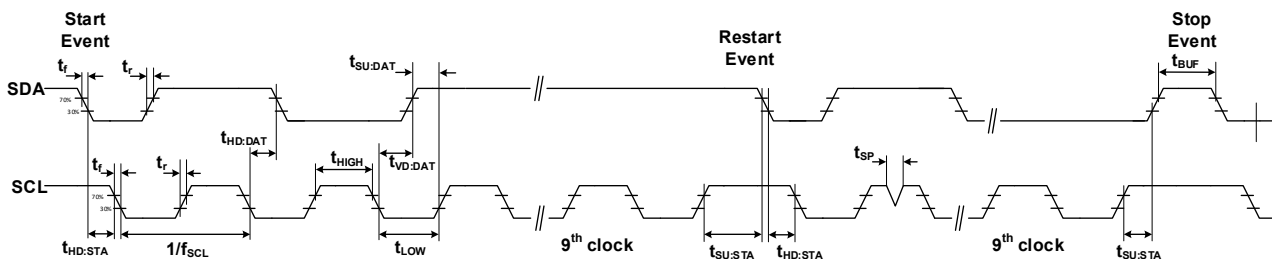

Figure 50. I²C Timing

Table 18. Timing Specifications

Parameter	Symbol	Standard Mode		Fast Mode		Fast Mode Plus		High Speed Mode		Unit
		Min	Max	Min	Max	Min	Max	Min	Max	
Clock frequency	f_{SCL}	0	100	0	400	0	1000	0	3400	kHz
Hold Time (repeated) START Condition. (After this period, the first clock pulse is generated.)	$t_{HD;STA}$	4000		600		260		160		ns
LOW Period of the SCL Clock	t_{LOW}	4700		1300		500		160		ns
HIGH Period of the SCL Clock	t_{HIGH}	4000		600		260		60		ns
Set-Up Time for a Repeated START Condition	$t_{SU;STA}$	4700		600		260		160		ns
Data Hold Time	$t_{HD;DAT}$	15		15		15		15	70	ns
Data Set-Up Time	$t_{SU;DAT}$	250		100		50		10		ns
Rise Time of SCL	t_{rCL}		1000		300		120		40	ns
Fall Time of SCL	t_{fCL}		300		300		120		40	ns
Rise Time of SDA	t_{rDA}		1000		300		120		80	ns
Fall Time of SDA	t_{fDA}		300		300		120		80	ns
Set-Up Time for STOP Condition	$t_{SU;STO}$	4000		600		260		160		ns
Bus Free Time between a STOP and START Condition	t_{BUF}	4700		1300		500				ns
Capacitive Load for each Bus Line	C_b		400		400		400		100	pF
Output Fall Time from VIHmin to VILmax	t_{of}		250[5]	$20 \times (V_{DD}/5.5V)[6]$	250[5]	$20 \times (V_{DD}/5.5V)[6]$	120[7]	10 (Note 13)	80	ns
Pulse Width of Spikes Suppressed by the Input Filter	t_{SP}			0	50	0	50	0	10	ns

Notes:

12. Only valid for $V_{DD} < 4V$.13. Only valid for $V_{DD} < 1.9V$.14. V_{DD} is the pull-up source to the I²C lines (GPIO0, GPIO1).

8. Board Layout Recommendations

The ISL91211A and ISL91211B are 4-channel PMICs consisting of high frequency switching regulators with dual and single phase capability and the PCB layout is a very important design practice to ensure satisfactory performance. The power loop is composed of the output inductor L , the output capacitor C_{OUT} , the SW pin, and the PGND pin. It is important to make the power loop as small as possible and the connecting traces among them should be direct, short, and wide. The same practice should be applied to connections at the PVIN, the input capacitor should be placed as close as possible to PVIN and PGND pins of the corresponding power stage.

The switching node of the converter, the SW pin, and the traces connected to this node are very noisy, so keep the remote sense lines and other noise sensitive traces away from these traces. Keep the trace connecting between the SW pin and the inductor short and wide, use multiple copper planes in parallel with sufficient vias in between to maximize thermal performance and efficiency. It is recommended to only descend one layer for the phase traces to reduce the effective path to the inductor. Also, ensure the length and width of each inductor trace and number of vias used match resistances to help ensure proper current matching, when using the dual phase configuration in ISL91211A.

The ground of the input and output capacitors should be connected as close as possible. Use as much ground plane as possible underneath ISL91211A and ISL91211B to support high current flow, create a low impedance path for return current between the ISL91211A and ISL91211B, and the load. Use solid ground plane as much as possible, it helps isolate SW node traces and high-speed clock signals from interfering with remote sense lines in adjacent layers, and is helpful for good EMI performance.

Place an AVIN filter capacitor as close as possible to ISL91211A and ISL91211B but away from noise sources, and always reference the GND pad of the decoupling capacitor to a quiet GND plane. The AVIN and AGND pins of ISL91211A and ISL91211B should reference to a copper plane.

Do not use plated through-holes when passing the WLCSP pins to lower layers. It is recommended to use microvias that are staggered if they require to pass down multiple layers.

VOUT and RTN lines are used to sense the output voltage and should be routed directly to the load. Connecting the RTN line to ground away from the load causes a ground error in the output voltage load regulation due to parasitic ground resistance. Also, keep these traces away from switching nodes, which could be phase nodes or high-speed digital signals. The use of small low inductance (ESL) capacitors at the load improves noise immunity and transient response to the ISL91211A and ISL91211B.

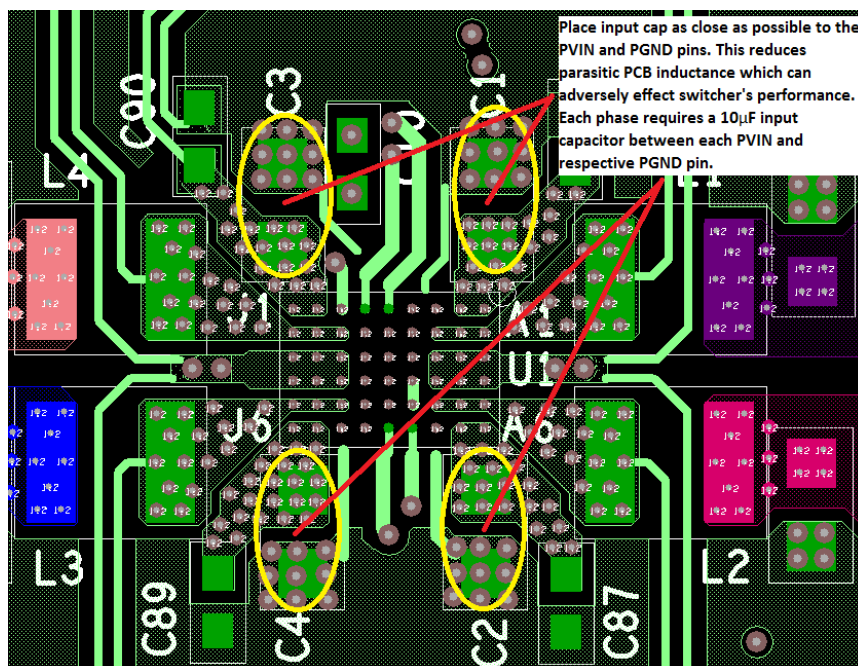

Figure 51. Recommended PCB Layout Top Layer

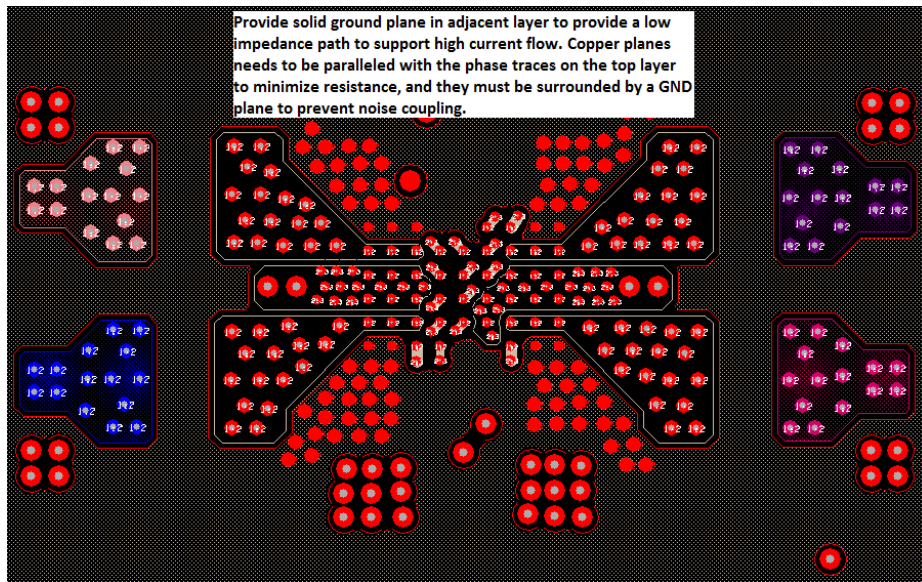

Figure 52. Recommended PCB Layout Second Layer

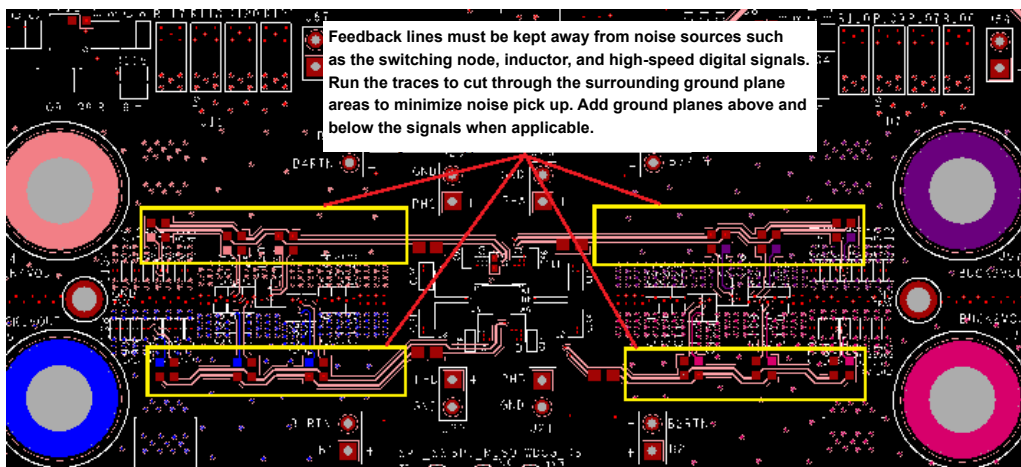

Figure 53. Recommended PCB Layout Bottom Layer

8.1 PCB Layout Summary

- Place input capacitors as close as possible to their respective PVIN and PGND pins.
- Route phase nodes with short, wide traces, and avoid any sensitive nodes.
- Route VOUT and RTN lines directly to the load using small, low inductance (ESL) capacitors at the load for bypassing.
- Output capacitors should be close to the inductors and have low impedance path to the PGND pins.
- Keep digital and phase nodes from intersecting AVIN_FILTER, VOUT, and RTN lines.
- Create a PGND plane on the 2nd layer of the PCB below the power components and bumps carrying high switching currents.

8.2 PCB Design for WLCSP Recommendations

Table 19. PCB Design for WLCSP Recommendations

Design Feature	Design Specification
Cu Pad Diameter	0.4mm pitch: $0.215 \pm 0.012\text{mm}$
Microvia Structure	All microvias should be copper filled.
Microvia Stacking	Avoid microvia stacking if possible. Use staggered vias instead. If microvia stacking is absolutely necessary for the layout, the maximum number of recommended via stacks is two.
Plated Through-Hole (PTH) Location	No PTH should be placed under the CSP bump pads. Microvias and trace routing should be used to fan the PTH away from the CSP bump array.

9. Register Address Map

Address	Register	Address	Register	Address	Register
0x01	IO_CHIPNAME	0x55	BUCK1_RSPCFG0	0x80	BUCK3_DVS2CFG1
0x13	FLT_RECORDTEMP	0x56	BUCK1_EN_DLY	0x81	BUCK3_DVS2CFG0
0x14	FLT_RECORDBUCK1	0x57	BUCK1_SHUTDN_DLY	0x82	BUCK3_DVS3CFG1
0x15	FLT_RECORDBUCK2	0x58	BUCK2_EA2	0x83	BUCK3_DVS3CFG0
0x16	FLT_RECORDBUCK3	0x5B	BUCK2_DCM	0x87	BUCK3_DVSSEL
0x17	FLT_RECORDBUCK4	0x5C	BUCK2_CFG3	0x88	BUCK3_RSPCFG1
0x23	IO_SPICFG	0x5D	BUCK2_CFG2	0x89	BUCK3_RSPCFG0
0x24	IO_MODECTRL	0x62	BUCK2_DVS0CFG1	0x8A	BUCK3_EN_DLY
0x32	FLT_MASKTEMP	0x63	BUCK2_DVS0CFG0	0x8B	BUCK3_SHUTDN_DLY
0x33	FLT_MASKBUCK1	0x64	BUCK2_DVS1CFG1	0x8C	BUCK4_EA2
0x34	FLT_MASKBUCK2	0x65	BUCK2_DVS1CFG0	0x8F	BUCK4_DCM
0x35	FLT_MASKBUCK3	0x66	BUCK2_DVS2CFG1	0x90	BUCK4_CFG3
0x36	FLT_MASKBUCK4	0x67	BUCK2_DVS2CFG0	0x96	BUCK4_DVS0CFG1
0x3B	BUCK1_EA2	0x68	BUCK2_DVS3CFG1	0x97	BUCK4_DVS0CFG0
0x3E	BUCK1_DCM	0x69	BUCK2_DVS3CFG0	0x98	BUCK4_DVS1CFG1
0x3F	BUCK1_CFG3	0x6D	BUCK2_DVSSEL	0x99	BUCK4_DVS1CFG0
0x46	BUCK1_PHADD	0x6E	BUCK2_RSPCFG1	0x9A	BUCK4_DVS2CFG1
0x48	BUCK1_DVS0CFG1	0x6F	BUCK2_RSPCFG0	0x9B	BUCK4_DVS2CFG0
0x49	BUCK1_DVS0CFG0	0x70	BUCK2_EN_DLY	0x9C	BUCK4_DVS3CFG1
0x4A	BUCK1_DVS1CFG1	0x71	BUCK2_SHUTDN_DLY	0x9D	BUCK4_DVS3CFG0
0x4B	BUCK1_DVS1CFG0	0x72	BUCK3_EA2	0xA1	BUCK4_DVSSEL
0x4C	BUCK1_DVS2CFG1	0x75	BUCK3_DCM	0xA2	BUCK4_RSPCFG1
0x4D	BUCK1_DVS2CFG0	0x76	BUCK3_CFG3	0xA3	BUCK4_RSPCFG0
0x4E	BUCK1_DVS3CFG1	0x7C	BUCK3_DVS0CFG1	0xA4	BUCK4_EN_DLY
0x4F	BUCK1_DVS3CFG0	0x7D	BUCK3_DVS0CFG0	0xA5	BUCK4_SHUTDN_DLY
0x53	BUCK1_DVSSEL	0x7E	BUCK3_DVS1CFG1		
0x54	BUCK1_RSPCFG1	0x7F	BUCK3_DVS1CFG0		

IMPORTANT: The registers not listed in the register map and the RESERVED bits are reserved for factory use only. Changing these registers/bits can result in unexpected operation.

10. Register Description by Address

Address	Bit	Name	R/W	Default	Description								
IO_CHIPNAME													
0x01	7:0	IO_CHIPNAME	R	0x03	<table border="1"> <tr> <td colspan="2">Chip Name</td> </tr> <tr> <td>0x03</td> <td>ISL91211A and ISL91211B</td> </tr> </table>	Chip Name		0x03	ISL91211A and ISL91211B				
Chip Name													
0x03	ISL91211A and ISL91211B												
FLT_RECORDTEMP													
0x13	7	FLT_BOOT	R	0x0	<table border="1"> <tr> <td colspan="2">BOOT Occurred</td> </tr> <tr> <td colspan="2">Read only, cleared when read</td> </tr> <tr> <td>0x0</td> <td>No boot process has occurred.</td> </tr> <tr> <td>0x1</td> <td>Boot process has occurred, OTP read is finished.</td> </tr> </table>	BOOT Occurred		Read only, cleared when read		0x0	No boot process has occurred.	0x1	Boot process has occurred, OTP read is finished.
	BOOT Occurred												
	Read only, cleared when read												
	0x0	No boot process has occurred.											
0x1	Boot process has occurred, OTP read is finished.												
6:2	RSVD	R	0x0	Reserved									
1	FLT_TEMPSDR	R	0x0	<table border="1"> <tr> <td colspan="2">Over-Temperature (OT) Shutdown (Rising Threshold)</td> </tr> <tr> <td colspan="2">Read only, cleared when read</td> </tr> <tr> <td>0x0</td> <td>No fault, less than threshold.</td> </tr> <tr> <td>0x1</td> <td>Fault, greater than threshold.</td> </tr> </table>	Over-Temperature (OT) Shutdown (Rising Threshold)		Read only, cleared when read		0x0	No fault, less than threshold.	0x1	Fault, greater than threshold.	
Over-Temperature (OT) Shutdown (Rising Threshold)													
Read only, cleared when read													
0x0	No fault, less than threshold.												
0x1	Fault, greater than threshold.												
0	FLT_TEMPSTR	R	0x0	<table border="1"> <tr> <td colspan="2">Over-Temperature (OT) Shutdown (Falling Threshold)</td> </tr> <tr> <td colspan="2">Read only, cleared when read</td> </tr> <tr> <td>0x0</td> <td>No fault, less than threshold.</td> </tr> <tr> <td>0x1</td> <td>Fault, greater than threshold.</td> </tr> </table>	Over-Temperature (OT) Shutdown (Falling Threshold)		Read only, cleared when read		0x0	No fault, less than threshold.	0x1	Fault, greater than threshold.	
Over-Temperature (OT) Shutdown (Falling Threshold)													
Read only, cleared when read													
0x0	No fault, less than threshold.												
0x1	Fault, greater than threshold.												
FLT_RECORDBUCK1													
0x14	7	RSVD	R	0x0	Reserved								
	6	FLT_BUCK1_OC	R	0x0	<table border="1"> <tr> <td colspan="2">Overcurrent (OC) for BUCK1</td> </tr> <tr> <td colspan="2">Read only, cleared when read</td> </tr> <tr> <td>0x0</td> <td>No fault, less than threshold.</td> </tr> <tr> <td>0x1</td> <td>Fault, greater than threshold.</td> </tr> </table>	Overcurrent (OC) for BUCK1		Read only, cleared when read		0x0	No fault, less than threshold.	0x1	Fault, greater than threshold.
	Overcurrent (OC) for BUCK1												
	Read only, cleared when read												
	0x0	No fault, less than threshold.											
0x1	Fault, greater than threshold.												
5	FLT_BUCK1_OV	R	0x0	<table border="1"> <tr> <td colspan="2">Overvoltage (OV)</td> </tr> <tr> <td colspan="2">Read only, cleared when read</td> </tr> <tr> <td>0x0</td> <td>No fault, less than threshold.</td> </tr> <tr> <td>0x1</td> <td>Fault, greater than threshold.</td> </tr> </table>	Overvoltage (OV)		Read only, cleared when read		0x0	No fault, less than threshold.	0x1	Fault, greater than threshold.	
Overvoltage (OV)													
Read only, cleared when read													
0x0	No fault, less than threshold.												
0x1	Fault, greater than threshold.												
4	FLT_BUCK1_UV	R	0x0	<table border="1"> <tr> <td colspan="2">Undervoltage (UV)</td> </tr> <tr> <td colspan="2">Read only, cleared when read</td> </tr> <tr> <td>0x0</td> <td>No fault, less than threshold.</td> </tr> <tr> <td>0x1</td> <td>Fault, greater than threshold.</td> </tr> </table>	Undervoltage (UV)		Read only, cleared when read		0x0	No fault, less than threshold.	0x1	Fault, greater than threshold.	
Undervoltage (UV)													
Read only, cleared when read													
0x0	No fault, less than threshold.												
0x1	Fault, greater than threshold.												
3:0	RSVD	R	0x0	Reserved									

Address	Bit	Name	R/W	Default	Description						
FLT_RECORDBUCK2											
0x15	7	RSVD	R	0x0	See "FLT_RECORDBUCK1"						
	6	FLT_BUCK2_OC	R	0x0							
	5	FLT_BUCK2_OV	R	0x0							
	4	FLT_BUCK2_UV	R	0x0							
	3:0	RSVD	R	0x0							
FLT_RECORDBUCK3											
0x16	7	RSVD	R	0x0	See "FLT_RECORDBUCK1"						
	6	FLT_BUCK3_OC	R	0x0							
	5	FLT_BUCK3_OV	R	0x0							
	4	FLT_BUCK3_UV	R	0x0							
	3:0	RSVD	R	0x0							
FLT_RECORDBUCK4											
0x17	7	RSVD	R	0x0	See "FLT_RECORDBUCK1"						
	6	FLT_BUCK4_OC	R	0x0							
	5	FLT_BUCK4_OV	R	0x0							
	4	FLT_BUCK4_UV	R	0x0							
	3:0	RSVD	R	0x0							
IO_SPICFG											
0x23	7:5	RSVD	R	0x0	Reserved						
	4	IO_IRQ_CMOS	R/W	0x0	<table border="1"> <thead> <tr> <th colspan="2">IRQ Type</th> </tr> </thead> <tbody> <tr> <td>0x0</td> <td>OD Output</td> </tr> <tr> <td>0x1</td> <td>CMOS Output</td> </tr> </tbody> </table>	IRQ Type		0x0	OD Output	0x1	CMOS Output
					IRQ Type						
	0x0	OD Output									
	0x1	CMOS Output									
3	IO_IRQ_INVERT	R/W	0x1	<table border="1"> <thead> <tr> <th colspan="2">IRQ Polarity</th> </tr> </thead> <tbody> <tr> <td>0x0</td> <td>Active High</td> </tr> <tr> <td>0x1</td> <td>Active Low</td> </tr> </tbody> </table>	IRQ Polarity		0x0	Active High	0x1	Active Low	
				IRQ Polarity							
0x0	Active High										
0x1	Active Low										
2:1	RSVD	R	0x0	Reserved							
0	RSVD	R	0x1	Reserved							

Address	Bit	Name	R/W	Default	Description						
IO_MODECTRL											
0x24	7	IO_BUCK1_EN	R/W	0x1	<table border="1"> <tr><td colspan="2">Enable for BUCK1</td></tr> <tr><td>0x0</td><td>Buck1 disabled.</td></tr> <tr><td>0x1</td><td>Buck1 enabled.</td></tr> </table>	Enable for BUCK1		0x0	Buck1 disabled.	0x1	Buck1 enabled.
	Enable for BUCK1										
	0x0	Buck1 disabled.									
	0x1	Buck1 enabled.									
	6	IO_BUCK2_EN	R/W	0x1	<table border="1"> <tr><td colspan="2">Enable for BUCK2</td></tr> <tr><td>0x0</td><td>Buck2 disabled.</td></tr> <tr><td>0x1</td><td>Buck2 enabled.</td></tr> </table>	Enable for BUCK2		0x0	Buck2 disabled.	0x1	Buck2 enabled.
	Enable for BUCK2										
	0x0	Buck2 disabled.									
	0x1	Buck2 enabled.									
5	IO_BUCK3_EN	R/W	0x1	<table border="1"> <tr><td colspan="2">Enable for BUCK3</td></tr> <tr><td>0x0</td><td>Buck3 disabled.</td></tr> <tr><td>0x1</td><td>Buck3 enabled.</td></tr> </table>	Enable for BUCK3		0x0	Buck3 disabled.	0x1	Buck3 enabled.	
Enable for BUCK3											
0x0	Buck3 disabled.										
0x1	Buck3 enabled.										
4	IO_BUCK4_EN	R/W	0x1	<table border="1"> <tr><td colspan="2">Enable for BUCK4</td></tr> <tr><td>0x0</td><td>Buck4 disabled.</td></tr> <tr><td>0x1</td><td>Buck4 enabled.</td></tr> </table>	Enable for BUCK4		0x0	Buck4 disabled.	0x1	Buck4 enabled.	
Enable for BUCK4											
0x0	Buck4 disabled.										
0x1	Buck4 enabled.										
3	RSVD	R	0x0	Reserved							
2	IO_ENVPPPULLDOWN	R/W	0x01	<table border="1"> <tr><td colspan="2">Enable for weak Pull-down on EN/VPP Pin</td></tr> <tr><td>0x0</td><td>Weak pull-down disabled.</td></tr> <tr><td>0x1</td><td>Weak pull-down enabled.</td></tr> </table>	Enable for weak Pull-down on EN/VPP Pin		0x0	Weak pull-down disabled.	0x1	Weak pull-down enabled.	
Enable for weak Pull-down on EN/VPP Pin											
0x0	Weak pull-down disabled.										
0x1	Weak pull-down enabled.										
1	RSVD	R	0x0	Reserved							
0	RSVD	R	0x1	Reserved							
FLT_MASKTEMP											
0x32	7	FLT_MASKBOOT	R/W	0x0	<table border="1"> <tr><td colspan="2">Mask IRQ for FLT_BOOT</td></tr> <tr><td>0x0</td><td>IRQ passed to output pin.</td></tr> <tr><td>0x1</td><td>IRQ masked from output pin.</td></tr> </table>	Mask IRQ for FLT_BOOT		0x0	IRQ passed to output pin.	0x1	IRQ masked from output pin.
	Mask IRQ for FLT_BOOT										
	0x0	IRQ passed to output pin.									
	0x1	IRQ masked from output pin.									
6-2	RSVD	R	0x0	Reserved							
1	FLT_MASKEMPSDR	R/W	0x0	<table border="1"> <tr><td colspan="2">Mask IRQ for FLT_TEMPSTR</td></tr> <tr><td>0x0</td><td>IRQ passed to output pin.</td></tr> <tr><td>0x1</td><td>IRQ masked from output pin.</td></tr> </table>	Mask IRQ for FLT_TEMPSTR		0x0	IRQ passed to output pin.	0x1	IRQ masked from output pin.	
Mask IRQ for FLT_TEMPSTR											
0x0	IRQ passed to output pin.										
0x1	IRQ masked from output pin.										
0	FLT_MASKTEMPSTR	R/W	0x0	<table border="1"> <tr><td colspan="2">Mask IRQ for FLT_TEMPSTR</td></tr> <tr><td>0x0</td><td>IRQ passed to output pin.</td></tr> <tr><td>0x1</td><td>IRQ masked from output pin.</td></tr> </table>	Mask IRQ for FLT_TEMPSTR		0x0	IRQ passed to output pin.	0x1	IRQ masked from output pin.	
Mask IRQ for FLT_TEMPSTR											
0x0	IRQ passed to output pin.										
0x1	IRQ masked from output pin.										

Address	Bit	Name	R/W	Default	Description						
FLT_MASKBUCK1											
0x33	7	RSVD	R	0x0	Reserved						
	6	FLT_BUCK1_MASKOC	R/W	0x0	<table border="1"> <tr> <td colspan="2">Mask IRQ for FLT_BUCK1_OC</td> </tr> <tr> <td>0x0</td> <td>IRQ passed to output pin.</td> </tr> <tr> <td>0x1</td> <td>IRQ masked from output pin.</td> </tr> </table>	Mask IRQ for FLT_BUCK1_OC		0x0	IRQ passed to output pin.	0x1	IRQ masked from output pin.
	Mask IRQ for FLT_BUCK1_OC										
	0x0	IRQ passed to output pin.									
	0x1	IRQ masked from output pin.									
5	FLT_BUCK1_MASKOV	R/W	0x0	<table border="1"> <tr> <td colspan="2">Mask IRQ for FLT_BUCK1_OV</td> </tr> <tr> <td>0x0</td> <td>IRQ passed to output pin.</td> </tr> <tr> <td>0x1</td> <td>IRQ masked from output pin.</td> </tr> </table>	Mask IRQ for FLT_BUCK1_OV		0x0	IRQ passed to output pin.	0x1	IRQ masked from output pin.	
Mask IRQ for FLT_BUCK1_OV											
0x0	IRQ passed to output pin.										
0x1	IRQ masked from output pin.										
4	FLT_BUCK1_MASKUV	R/W	0x0	<table border="1"> <tr> <td colspan="2">Mask IRQ for FLT_BUCK1_UV</td> </tr> <tr> <td>0x0</td> <td>IRQ passed to output pin.</td> </tr> <tr> <td>0x1</td> <td>IRQ masked from output pin.</td> </tr> </table>	Mask IRQ for FLT_BUCK1_UV		0x0	IRQ passed to output pin.	0x1	IRQ masked from output pin.	
Mask IRQ for FLT_BUCK1_UV											
0x0	IRQ passed to output pin.										
0x1	IRQ masked from output pin.										
3-0	RSVD	R	0x0	Reserved							
FLT_MASKBUCK2											
0x34	7	RSVD	R	0x0	See "FLT_MASKBUCK1"						
	6	FLT_BUCK2_MASKOC	R/W	0x0							
	5	FLT_BUCK2_MASKOV	R/W	0x0							
	4	FLT_BUCK2_MASKUV	R/W	0x0							
	3-0	RSVD	R	0x0							
FLT_MASKBUCK3											
0x35	7	RSVD	R	0x0	See "FLT_MASKBUCK1"						
	6	FLT_BUCK3_MASKOC	R/W	0x0							
	5	FLT_BUCK3_MASKOV	R/W	0x0							
	4	FLT_BUCK3_MASKUV	R/W	0x0							
	3-0	RSVD	R	0x0							
FLT_MASKBUCK4											
0x36	7	RSVD	R	0x0	See "FLT_MASKBUCK1"						
	6	FLT_BUCK4_MASKOC	R/W	0x0							
	5	FLT_BUCK4_MASKOV	R/W	0x0							
	4	FLT_BUCK4_MASKUV	R/W	0x0							
	3-0	RSVD	R	0x0							

Address	Bit	Name	R/W	Default	Description															
BUCK1_EA2																				
0x3B	7-6	BUCK1_VOUTFBDIV	R/W	0x0	<p>V_{OUT} feedback divider ratio for the control loop. Should only be changed when the Buck is Disabled (BUCK1_EN = 0).</p> <table border="1"> <thead> <tr> <th></th> <th>Feedback Divider (FBDIV) (%)</th> <th>V_{OUT} Max (V)</th> </tr> </thead> <tbody> <tr> <td>0x0</td> <td>100</td> <td>1.2</td> </tr> <tr> <td>0x1</td> <td>80</td> <td>1.5</td> </tr> <tr> <td>0x2</td> <td>60</td> <td>2.0</td> </tr> <tr> <td>0x3</td> <td>Reserved</td> <td>Reserved</td> </tr> </tbody> </table>		Feedback Divider (FBDIV) (%)	V_{OUT} Max (V)	0x0	100	1.2	0x1	80	1.5	0x2	60	2.0	0x3	Reserved	Reserved
		Feedback Divider (FBDIV) (%)	V_{OUT} Max (V)																	
0x0	100	1.2																		
0x1	80	1.5																		
0x2	60	2.0																		
0x3	Reserved	Reserved																		
5-0	RSVD		R/W	N/A	Reserved. Not Available.															
BUCK1_DCM																				
0x3E	7:3	Reserved	R	0x0	Reserved															
	2	BUCK1_FCCM	R/W	0x0	<p>Forced Continuous Conduction Mode</p> <table border="1"> <tbody> <tr> <td>0x0</td> <td>DCM allowed when load reaches 0A</td> </tr> <tr> <td>0x1</td> <td>Always operate in CCM (Continuous Conduction Mode)</td> </tr> </tbody> </table>	0x0	DCM allowed when load reaches 0A	0x1	Always operate in CCM (Continuous Conduction Mode)											
	0x0	DCM allowed when load reaches 0A																		
0x1	Always operate in CCM (Continuous Conduction Mode)																			
1:0	Reserved		R/W	0x0	Reserved															
BUCK1_CFG3																				
0x3F	7-6	BUCK1_FSEL	ORW	0x2	<p>Buck's steady-state switching frequency.</p> <table border="1"> <tbody> <tr> <td>0x0</td> <td>2MHz</td> </tr> <tr> <td>0x1</td> <td>3MHz</td> </tr> <tr> <td>0x2</td> <td>4MHz</td> </tr> <tr> <td>0x3</td> <td>Reserved</td> </tr> </tbody> </table>	0x0	2MHz	0x1	3MHz	0x2	4MHz	0x3	Reserved							
	0x0	2MHz																		
	0x1	3MHz																		
0x2	4MHz																			
0x3	Reserved																			
5-1	RSVD		N/A	N/A	Reserved															
0	RSVD		N/A	N/A	Reserved															
BUCK1_PHADD																				
0x46	7-3	RSVD	N/A	0x0	Reserved. Not Available															
	2	BUCK1_MANUALMODE	ORW	0x0	<p>Automatic Phase Add/Drop Control</p> <table border="1"> <tbody> <tr> <td>0x0</td> <td>Automatic Phase Add/Drop</td> </tr> <tr> <td>0x1</td> <td>Manual Phase Add/Drop</td> </tr> </tbody> </table> <p>Note: This functionality is only available in ISL91211A.</p>	0x0	Automatic Phase Add/Drop	0x1	Manual Phase Add/Drop											
	0x0	Automatic Phase Add/Drop																		
0x1	Manual Phase Add/Drop																			
1-0	BUCK1_MANUALPH	ORW	0x2	<p>Sets the number of active phases when using Manual Phase Add/Drop Mode</p> <table border="1"> <tbody> <tr> <td>0x1</td> <td>1-phase mode</td> </tr> <tr> <td>0x0, 0x2, 0x3</td> <td>2-phase mode</td> </tr> </tbody> </table> <p>Note: In Manual Phase Add/Drop mode (BUCK1_MANUALMODE = 0x1) and 2-phase mode (BUCK1_MANUALPH = 0x0 or 0x2 or 0x3), the part operates in Forced CCM 2-phase configuration.</p>	0x1	1-phase mode	0x0, 0x2, 0x3	2-phase mode												
0x1	1-phase mode																			
0x0, 0x2, 0x3	2-phase mode																			

Address	Bit	Name	R/W	Default	Description																																				
BUCK1_DVS0CFG1																																									
0x48	7-0	BUCK1_DVS0VOUT92	R/W	TRIM for 0.9V	<p>Upper eight bits of a 10-bit DAC[9:0] value to generate V_{OUT} for DVS Configuration 0.</p> <p>Note: V_{OUT} must be programmed above 0.3V. FBDIV is set by factory OTP to 1x, 0.8x, 0.6x.</p> <table border="1"> <thead> <tr> <th>FBDIV</th> <th>1.0</th> <th>0.8</th> <th>0.6</th> </tr> <tr> <th>DAC</th> <th>V_{OUT} (V)</th> <th>V_{OUT} (V)</th> <th>V_{OUT} (V)</th> </tr> </thead> <tbody> <tr> <td>0x000</td> <td>0.0000</td> <td>0.0000</td> <td>0.0000</td> </tr> <tr> <td>0x001</td> <td>0.0012</td> <td>0.0015</td> <td>0.0020</td> </tr> <tr> <td>...</td> <td></td> <td></td> <td></td> </tr> <tr> <td>0x200</td> <td>0.6173</td> <td>0.7716</td> <td>1.0288</td> </tr> <tr> <td>0x201</td> <td>0.6185</td> <td>0.7731</td> <td>1.0308</td> </tr> <tr> <td>...</td> <td></td> <td></td> <td></td> </tr> <tr> <td>0x3E5</td> <td>1.199</td> <td>1.4988</td> <td>1.9983</td> </tr> </tbody> </table>	FBDIV	1.0	0.8	0.6	DAC	V_{OUT} (V)	V_{OUT} (V)	V_{OUT} (V)	0x000	0.0000	0.0000	0.0000	0x001	0.0012	0.0015	0.0020	...				0x200	0.6173	0.7716	1.0288	0x201	0.6185	0.7731	1.0308	...				0x3E5	1.199	1.4988	1.9983
FBDIV	1.0	0.8	0.6																																						
DAC	V_{OUT} (V)	V_{OUT} (V)	V_{OUT} (V)																																						
0x000	0.0000	0.0000	0.0000																																						
0x001	0.0012	0.0015	0.0020																																						
...																																									
0x200	0.6173	0.7716	1.0288																																						
0x201	0.6185	0.7731	1.0308																																						
...																																									
0x3E5	1.199	1.4988	1.9983																																						
BUCK1_DVS0CFG0																																									
0x49	7-6	BUCK1_DVS0VOUT10	R/W	TRIM for 0.9V	<p>Lower two bits of a 10-bit DAC[9:0] value to generate V_{OUT} for DVS configuration.</p> <p>Note: When DVS Configuration 0 is selected (using pins or registers) any write to BUCK1_DVS0CFG0 causes a DVS ramping to occur.</p> <p>For details, see "Dynamic Voltage Scaling (DVS)" on page 22.</p>																																				
	5	RSVD	R	0x0	Reserved																																				
	4-1	RSVD	R	0x0	Reserved																																				
	0	RSVD	R	0x0	Reserved																																				
BUCK1_DVS1CFG1																																									
0x4A	7-0	BUCK1_DVS1VOUT92	R/W	0xBF	See "BUCK1_DVS0CFG1"																																				
BUCK1_DVS1CFG0																																									
0x4B	7-6	BUCK1_DVS1VOUT10	R/W	0x3	See "BUCK1_DVS0CFG0"																																				
	5	RSVD	R	0x0																																					
	4-1	RSVD	R	0x0																																					
	0	RSVD	R	0x0																																					
BUCK1_DVS2CFG1																																									
0x4C	7-0	BUCK1_DVS2VOUT92	R/W	0x58	See "BUCK1_DVS0CFG1"																																				
BUCK1_DVS2CFG0																																									
0x4D	7-6	BUCK1_DVS2VOUT10	R/W	0x0	See "BUCK1_DVS0CFG0"																																				
	5	RSVD	R	0x0																																					
	4-1	RSVD	R	0x0																																					
	0	RSVD	R	0x0																																					
BUCK1_DVS3CFG1																																									
0x4E	7-0	BUCK1_DVS3VOUT92	R/W	0x00	See "BUCK1_DVS0CFG1"																																				

Address	Bit	Name	R/W	Default	Description
BUCK1_DVS3CFG0					
0x4F	7-6	BUCK1_DVS3VOUT10	R/W	0x0	See "BUCK1_DVS0CFG0"
	5	RSVD	R	0x0	
	4-1	RSVD	R	0x0	
	0	RSVD	R	0x0	
BUCK1_DVSSEL					
0x53	7-3	RSVD	R	0x0	Reserved
	2	BUCK1_DVSCTRL	R/W	0x0	BUCK1 DVS Control
					0x0 Use BUCK1_DVSSELECT to select active DVS configuration.
1-0	BUCK1_DVSSELECT	R/W	0x0	BUCK1 DVS Selection	
	0x0				Use DVS Configuration 0 in BUCK1_DVS0CFG and BUCK1_DVS0VOUT.
	0x1				Use DVS Configuration 1 in BUCK1_DVS1CFG and BUCK1_DVS1VOUT.
	0x2				Use DVS Configuration 2 in BUCK1_DVS2CFG and BUCK1_DVS2VOUT.
	0x3				Use DVS Configuration 3 in BUCK1_DVS3CFG and BUCK1_DVS3VOUT. Note: When BUCK1_DVSCTRL = 0x0 any write to the register BUCK1_DVSSEL causes a DVS ramping event to occur.

Address	Bit	Name	R/W	Default	Description																																																							
BUCK1_RSPCFG1																																																												
0x54	7	RSVD	R	0x0	Reserved																																																							
	6-4	BUCK1_RSPUP	R/W	0x7	<p>V_{OUT} Ramp Slew Rate RSP = BUCK1_RSPUP[1:0], Ramp Speed FBDIV = BUCK1_VOUTFBDIV[1:0] = (1.0, 0.8, 0.6) Slow = BUCK1_RSPUP[2] = 0 Fast = BUCK1_RSPUP[2] = 1</p> <table border="1"> <thead> <tr> <th colspan="2"></th> <th colspan="2">V_{OUT} Ramp Speed mV/μs</th> </tr> <tr> <th>RSP</th> <th>FBDIV</th> <th>Fast</th> <th>Slow</th> </tr> </thead> <tbody> <tr> <td>0x0</td> <td>1.0</td> <td>12</td> <td>3</td> </tr> <tr> <td>0x1</td> <td>1.0</td> <td>24</td> <td>6</td> </tr> <tr> <td>0x2</td> <td>1.0</td> <td>58</td> <td>14</td> </tr> <tr> <td>0x3</td> <td>1.0</td> <td>115</td> <td>29</td> </tr> </tbody> </table> <table border="1"> <thead> <tr> <th colspan="2"></th> <th colspan="2">V_{OUT} Ramp Speed mV/μs</th> </tr> <tr> <th>RSP</th> <th>FBDIV</th> <th>Fast</th> <th>Slow</th> </tr> </thead> <tbody> <tr> <td>0x0</td> <td>0.8</td> <td>12</td> <td>3</td> </tr> <tr> <td>0x1</td> <td>0.8</td> <td>24</td> <td>6</td> </tr> </tbody> </table> <table border="1"> <thead> <tr> <th colspan="2"></th> <th colspan="2">V_{OUT} Ramp Speed mV/μs</th> </tr> <tr> <th>RSP</th> <th>FBDIV</th> <th>Fast</th> <th>Slow</th> </tr> </thead> <tbody> <tr> <td>0x0</td> <td>0.6</td> <td>12</td> <td>3</td> </tr> <tr> <td>0x1</td> <td>0.6</td> <td>24</td> <td>6</td> </tr> </tbody> </table>			V_{OUT} Ramp Speed mV/ μ s		RSP	FBDIV	Fast	Slow	0x0	1.0	12	3	0x1	1.0	24	6	0x2	1.0	58	14	0x3	1.0	115	29			V_{OUT} Ramp Speed mV/ μ s		RSP	FBDIV	Fast	Slow	0x0	0.8	12	3	0x1	0.8	24	6			V_{OUT} Ramp Speed mV/ μ s		RSP	FBDIV	Fast	Slow	0x0	0.6	12	3	0x1	0.6	24
		V_{OUT} Ramp Speed mV/ μ s																																																										
RSP	FBDIV	Fast	Slow																																																									
0x0	1.0	12	3																																																									
0x1	1.0	24	6																																																									
0x2	1.0	58	14																																																									
0x3	1.0	115	29																																																									
		V_{OUT} Ramp Speed mV/ μ s																																																										
RSP	FBDIV	Fast	Slow																																																									
0x0	0.8	12	3																																																									
0x1	0.8	24	6																																																									
		V_{OUT} Ramp Speed mV/ μ s																																																										
RSP	FBDIV	Fast	Slow																																																									
0x0	0.6	12	3																																																									
0x1	0.6	24	6																																																									
	3	RSVD	R/W	0x0	Reserved																																																							
	2-0	BUCK1_RSPDN	R/W	0x3	See "BUCK1_RSPUP" for rate definition																																																							

Address	Bit	Name	R/W	Default	Description																																																								
BUCK1_RSPCFG0																																																													
0x55	7	RSVD	R	0x0	Reserved																																																								
	6-4	BUCK1_RSPPUP	R/W	0x7	<p>VOUT Ramp Slew Rate RSP = BUCK1_RSPPUP[1:0], Ramp Speed FBDIV = BUCK1_VOUTFBDIV[1:0] = (1.0, 0.8, 0.6) Slow = BUCK1_RSPPUP[2] = 0 Fast = BUCK1_RSPPUP[2] = 1</p> <table border="1"> <thead> <tr> <th colspan="2"></th> <th colspan="2">V_{OUT} Ramp Speed mV/μs</th> </tr> <tr> <th>RSP</th> <th>FBDIV</th> <th>Fast</th> <th>Slow</th> </tr> </thead> <tbody> <tr> <td>0x0</td> <td>1.0</td> <td>6</td> <td>1.2</td> </tr> <tr> <td>0x1</td> <td>1.0</td> <td>12</td> <td>3</td> </tr> <tr> <td>0x2</td> <td>1.0</td> <td>29</td> <td>7.2</td> </tr> <tr> <td>0x3</td> <td>1.0</td> <td>58</td> <td>15</td> </tr> </tbody> </table> <table border="1"> <thead> <tr> <th colspan="2"></th> <th colspan="2">V_{OUT} Ramp Speed mV/μs</th> </tr> <tr> <th>RSP</th> <th>FBDIV</th> <th>Fast</th> <th>Slow</th> </tr> </thead> <tbody> <tr> <td>0x0</td> <td>0.8</td> <td>12</td> <td>3</td> </tr> <tr> <td>0x1</td> <td>0.8</td> <td>24</td> <td>6</td> </tr> </tbody> </table> <table border="1"> <thead> <tr> <th colspan="2"></th> <th colspan="2">V_{OUT} Ramp Speed mV/μs</th> </tr> <tr> <th>RSP</th> <th>FBDIV</th> <th>Fast</th> <th>Slow</th> </tr> </thead> <tbody> <tr> <td>0x0</td> <td>0.6</td> <td>12</td> <td>3</td> </tr> <tr> <td>0x1</td> <td>0.6</td> <td>24</td> <td>6</td> </tr> </tbody> </table>			V _{OUT} Ramp Speed mV/μs		RSP	FBDIV	Fast	Slow	0x0	1.0	6	1.2	0x1	1.0	12	3	0x2	1.0	29	7.2	0x3	1.0	58	15			V _{OUT} Ramp Speed mV/μs		RSP	FBDIV	Fast	Slow	0x0	0.8	12	3	0x1	0.8	24	6			V _{OUT} Ramp Speed mV/μs		RSP	FBDIV	Fast	Slow	0x0	0.6	12	3	0x1	0.6	24	6
							V _{OUT} Ramp Speed mV/μs																																																						
					RSP	FBDIV	Fast	Slow																																																					
					0x0	1.0	6	1.2																																																					
0x1	1.0	12	3																																																										
0x2	1.0	29	7.2																																																										
0x3	1.0	58	15																																																										
		V _{OUT} Ramp Speed mV/μs																																																											
RSP	FBDIV	Fast	Slow																																																										
0x0	0.8	12	3																																																										
0x1	0.8	24	6																																																										
		V _{OUT} Ramp Speed mV/μs																																																											
RSP	FBDIV	Fast	Slow																																																										
0x0	0.6	12	3																																																										
0x1	0.6	24	6																																																										
3	BUCK	R/W	0x0	Reserved																																																									
2-0	BUCK1_RSPPDN	R/W	0x3	See " BUCK1_RSPPUP " for rate definition																																																									
BUCK1_EN_DLY																																																													
0x56	1-0	BUCK1_ENPIN_CFG	R/W	0x0	<p>EN_X pin control is valid only in PINMODE 1. BUCK EN Control = IO_BUCK1_EN and BUCK1_EN_PIN If not in PINMODE 1, BUCK1_EN_PIN is default high, only IO_BUCK1_EN can toggle BUCK1 EN</p> <table border="1"> <thead> <tr> <th colspan="2">BUCK1_EN_PIN</th> </tr> </thead> <tbody> <tr> <td>0x0</td> <td>EN_A</td> </tr> <tr> <td>0x1</td> <td>EN_B</td> </tr> <tr> <td>0x2</td> <td>EN_C</td> </tr> <tr> <td>0x3</td> <td>1</td> </tr> </tbody> </table>	BUCK1_EN_PIN		0x0	EN_A	0x1	EN_B	0x2	EN_C	0x3	1																																														
	BUCK1_EN_PIN																																																												
0x0	EN_A																																																												
0x1	EN_B																																																												
0x2	EN_C																																																												
0x3	1																																																												
5-0	BUCK1_EN_DLY	R/W	0x0	<p>Delay time from BUCK_EN pin and IO_REGVAID go high to buck1_en control asserted. Delay = (integer value of register) ms [1ms/LSB]</p>																																																									

Address	Bit	Name	R/W	Default	Description										
BUCK1_SHUTDOWN_DLY															
0x57	1-0	BUCK1_DVSPIN_CFG	R/W	0x0	DVS_PIN_X pin control is valid only in PINMODE 3. DVS_1 = 0 DVS_0 = BUCK1_DVS_PIN0 and BUCK1_DVS_CTRL If not in PINMODE 3, DVS_PIN_x function is disabled <table border="1" data-bbox="760 436 1321 638"> <tr> <td colspan="2">BUCK1_DVS_PIN0</td> </tr> <tr> <td>0x0</td> <td>EN_A</td> </tr> <tr> <td>0x1</td> <td>EN_B</td> </tr> <tr> <td>0x2</td> <td>EN_C</td> </tr> <tr> <td>0x3</td> <td>1</td> </tr> </table>	BUCK1_DVS_PIN0		0x0	EN_A	0x1	EN_B	0x2	EN_C	0x3	1
	BUCK1_DVS_PIN0														
0x0	EN_A														
0x1	EN_B														
0x2	EN_C														
0x3	1														
5-0	BUCK1_SHUTDOWN_DLY	R/W	0x0	Delay time from BUCK_EN pin or IO_REGVAID go low to buck1_en control de-asserted. Delay = (integer value of register) ms [1ms/LSB]											
BUCK2_EA2															
0x58	7-6	BUCK2_VOUTFBDIV	R/W	0x0	See "BUCK1_EA2"										
	5-0	RSVD	R/W	N/A											
BUCK2_DCM															
0x5B	7:3	Reserved	R	0x0	Reserved										
	2	BUCK2_FCCM	R/W	0x0	See "BUCK1_DCM"										
	1:0	Reserved	R/W	0x0	Reserved										
BUCK2_CFG3															
0x5C	7:6	BUCK2_FSEL[1:0]	R/W	0x0	See "BUCK1_CFG3"										
	5-0	RSVD	R/W	N/A											
BUCK2_CFG2															
0x5D	7:4	RSVD	R/W	0x8	Reserved										
	3	RSVD	R	TRIM	Reserved										
	2	RSVD	R	0x0	Reserved										
	1:0	PULL_DOWN_DISCHARGE	R/W	0x0	<table border="1" data-bbox="760 1339 1312 1461"> <tr> <td colspan="2">VOUT pulldown when BUCK is shut off</td> </tr> <tr> <td>0x0</td> <td>Disable VOUT pulldown</td> </tr> <tr> <td>0x1</td> <td>Enable VOUT pulldown.</td> </tr> </table> Applies the weak pull-down feature for all the buck outputs. 1: Weak pull-down resistor is enabled when the buck output is turned off by software and master EN remains asserted. 0: Weak pull-down resistor is disabled when the buck output is turned off by software and master EN remains asserted.	VOUT pulldown when BUCK is shut off		0x0	Disable VOUT pulldown	0x1	Enable VOUT pulldown.				
VOUT pulldown when BUCK is shut off															
0x0	Disable VOUT pulldown														
0x1	Enable VOUT pulldown.														
BUCK2_DVS0CFG1															
0x62	7-0	BUCK2_DVS0VOUT92	R/W	0xBF	See "BUCK1_DVS0VOUT92"										
BUCK2_DVS0CFG0															
0x63	7-6	BUCK2_DVS0VOUT10	R/W	0x3	See "BUCK1_DVS0CFG0"										
	5	RSVD	R	0x0											
	4-1	RSVD	R	0x0											
	0	RSVD	R	0x0											

Address	Bit	Name	R/W	Default	Description
BUCK2_DVS1CFG1					
0x64	7-0	BUCK2_DVS1VOUT92	R/W	0xBF	See "BUCK1_DVS0CFG1"
BUCK2_DVS1CFG0					
0x65	7-6	BUCK2_DVS1VOUT10	R/W	0x3	See "BUCK1_DVS0CFG0"
	5	RSVD	R	0x0	
	4-1	RSVD	R	0x0	
	0	RSVD	R	0x0	
BUCK2_DVS2CFG1					
0x66	7-0	BUCK1_DVS2VOUT92	R/W	0x58	See "BUCK1_DVS0CFG1"
BUCK2_DVS2CFG0					
0x67	7-6	BUCK2_DVS2VOUT10	R/W	0x0	See "BUCK1_DVS0CFG0"
	5	RSVD	R	0x0	
	4-1	RSVD	R	0x0	
	0	RSVD	R	0x0	
BUCK2_DVS3CFG1					
0x68	7-0	BUCK2_DVS3VOUT92	R/W	0x00	See "BUCK1_DVS0CFG1"
BUCK2_DVS3CFG0					
0x69	7-6	BUCK2_DVS3VOUT10	R/W	0x0	See "BUCK1_DVS0CFG0"
	5	RSVD	R	0x0	
	4-1	RSVD	R	0x0	
	0	RSVD	R	0x0	
BUCK2_DVSSEL					
0x6D	7-3	RSVD	R	0x0	See "BUCK1_DVSSEL"
	2	BUCK1_DVSCTRL	R/W	0x0	
	1-0	BUCK1_DVSSELECT	R/W	0x0	
BUCK2_RSPCFG1					
0x6E	7	RSVD	R	0x0	See "BUCK1_RSPCFG1"
	6-4	BUCK2_RSPUP	R/W	0x7	
	3	RSVD	R	0x0	
	2-0	BUCK2_RSPDN	R/W	0x3	
BUCK2_RSPCFG0					
0x6F	7	RSVD	R	0x0	See "BUCK1_RSPCFG0"
	6-4	BUCK2_RSPPUP	R/W	0x7	
	3	RSVD	R	0x0	
	2-0	BUCK2_RSPPDN	R/W	0x3	
BUCK2_EN_DLY					
0x70	1-0	BUCK2_ENPIN_CFG	R/W	0x1	See "BUCK1_ENPIN_CFG"
	5-0	BUCK2_EN_DLY	R/W	0x0	See "BUCK1_EN_DLY"
BUCK2_SHUTDN_DLY					
0x71	1-0	BUCK2_DVSPIN_CFG	R/W	0x1	See "BUCK1_DVSPIN_CFG"
	5-0	BUCK2_SHUTDN_DLY	R/W	0x0	See "BUCK1_SHUTDN_DLY"

Address	Bit	Name	R/W	Default	Description
BUCK3_EA2					
0x72	7-6	BUCK3_VOUTFBDIV	R/W	0x0	See "BUCK1_EA2"
	5-0	RSVD	R/W	N/A	
BUCK3_DCM					
0x75	7:3	Reserved	R	0x0	Reserved
	2	BUCK3_FCCM	R/W	0x0	See "BUCK1_DCM"
	1:0	Reserved	R/W	0x0	Reserved
BUCK3_CFG3					
0x76	7:6	BUCK3_FSEL[1:0]	R/W	0x0	See "BUCK1_CFG3"
	5-0	RSVD	R/W	N/A	
BUCK3_DVS0CFG1					
0x7C	7-0	BUCK3_DVS0VOUT92	R/W	0xFF	See "BUCK1_DVS0VOUT92"
BUCK3_DVS0CFG0					
0x7D	7-6	BUCK3_DVS0VOUT10	R/W	0x3	See "BUCK1_DVS0CFG0"
	5	RSVD	R	0x0	
	4-1	RSVD	R	0x0	
	0	RSVD	R	0x0	
BUCK3_DVS1CFG1					
0x7E	7-0	BUCK3_DVS1VOUT92	R/W	0xBF	See "BUCK1_DVS0CFG1"
BUCK3_DVS1CFG0					
0x7F	7-6	BUCK3_DVS1VOUT10	R/W	0x3	See "BUCK1_DVS0CFG0"
	5	RSVD	R	0x0	
	4-1	RSVD	R	0x0	
	0	RSVD	R	0x0	
BUCK3_DVS2CFG1					
0x80	7-0	BUCK3_DVS2VOUT92	R/W	0x58	See "BUCK1_DVS0CFG1"
BUCK3_DVS2CFG0					
0x81	7-6	BUCK3_DVS2VOUT10	R/W	0x0	See "BUCK1_DVS0CFG0"
	5	RSVD	R	0x0	
	4-1	RSVD	R	0x0	
	0	RSVD	R	0x0	
BUCK3_DVS3CFG1					
0x82	7-0	BUCK3_DVS3VOUT92	R/W	0x00	See "BUCK1_DVS0CFG1"
BUCK3_DVS3CFG0					
0x83	7-6	BUCK3_DVS3VOUT10	R/W	0x0	See "BUCK1_DVS0CFG0"
	5	RSVD	R	0x0	
	4-1	RSVD	R	0x0	
	0	RSVD	R	0x0	
BUCK3_DVSSEL					
0x87	7-3	RSVD	R	0x0	See "BUCK1_DVSSEL"
	2	BUCK3_DVSCTRL	R/W	0x0	
	1-0	BUCK3_DVSSELECT	R/W	0x0	

Address	Bit	Name	R/W	Default	Description
BUCK3_RSPCFG1					
0x88	7	RSVD	R	0x0	See "BUCK1_RSPCFG1"
	6-4	BUCK3_RSPUP	R/W	0x7	
	3	RSVD	R	0x0	
	2-0	BUCK3_RSPDN	R/W	0x3	
BUCK3_RSPCFG0					
0x89	7	RSVD	R	0x0	See "BUCK1_RSPCFG0"
	6-4	BUCK3_RSPPUP	R/W	0x7	
	3	RSVD	R	0x0	
	2-0	BUCK3_RSPPDN	R/W	0x3	
BUCK3_EN_DLY					
0x8A	1-0	BUCK3_ENPIN_CFG	R/W	0x2	See "BUCK1_ENPIN_CFG"
	5-0	BUCK3_EN_DLY	R/W	0x0	See "BUCK1_EN_DLY"
BUCK3_SHUTDOWN_DLY					
0x8B	1-0	BUCK3_DVSPIN_CFG	R/W	0x2	See "BUCK1_DVSPIN_CFG"
	5-0	BUCK3_SHUTDOWN_DLY	R/W	0x0	See "BUCK1_SHUTDOWN_DLY"
BUCK4_EA2					
0x8C	7-6	BUCK4_VOUTFBDIV	R/W	0x0	See "BUCK1_EA2"
	5-0	RSVD	R/W	N/A	
BUCK4_DCM					
0x8F	7:3	Reserved	R	0x0	Reserved
	2	BUCK4_FCCM	R/W	0x0	See "BUCK1_DCM"
	1:0	Reserved	R/W	0x0	Reserved
BUCK4_CFG3					
0x90	7:6	BUCK4_FSEL[1:0]	R/W	0x0	See "BUCK1_CFG3"
	5-0	RSVD	R/W	N/A	
BUCK4_DVS0CFG1					
0x96	7-0	BUCK4_DVS0VOUT92	R/W	0xFF	See "BUCK1_DVS0VOUT92"
BUCK4_DVS0CFG0					
0x97	7-6	BUCK4_DVS0VOUT10	R/W	0x3	See "BUCK1_DVS0CFG0"
	5	RSVD	R	0x0	
	4-1	RSVD	R	0x0	
	0	RSVD	R	0x0	
BUCK4_DVS1CFG1					
0x98	7-0	BUCK4_DVS1VOUT92	R/W	0xBF	See "BUCK1_DVS0CFG1"
BUCK4_DVS1CFG0					
0x99	7-6	BUCK4_DVS1VOUT10	R/W	0x3	See "BUCK1_DVS0CFG0"
	5	RSVD	R	0x0	
	4-1	RSVD	R	0x0	
	0	RSVD	R	0x0	
BUCK4_DVS2CFG1					
0x9A	7-0	BUCK4_DVS2VOUT92	R/W	0x58	See "BUCK1_DVS0CFG1"

Address	Bit	Name	R/W	Default	Description
BUCK4_DVS2CFG0					
0x9B	7-6	BUCK4_DVS2VOUT10	R/W	0x0	See "BUCK1_DVS0CFG0"
	5	RSVD	R	0x0	
	4-1	RSVD	R	0x0	
	0	RSVD	R	0x0	
BUCK4_DVS3CFG1					
0x9C	7-0	BUCK4_DVS3VOUT92	R/W	0x00	See "BUCK1_DVS0CFG1"
BUCK4_DVS3CFG0					
0x9D	7-6	BUCK4_DVS3VOUT10	R/W	0x0	See "BUCK1_DVS0CFG0"
	5	RSVD	R	0x0	
	4-1	RSVD	R	0x0	
	0	RSVD	R	0x0	
BUCK4_DVSSEL					
0xA1	7-3	RSVD	R	0x0	See "BUCK1_DVSSEL"
	2	BUCK4_DVSCTRL	R/W	0x0	
	1-0	BUCK4_DVSSELECT	R/W	0x0	
BUCK4_RSPCFG1					
0xA2	7	RSVD	R	0x0	See "BUCK1_RSPCFG1"
	6-4	BUCK4_RSPUP	R/W	0x7	
	3	RSVD	R	0x0	
	2-0	BUCK4_RSPDN	R/W	0x3	
BUCK4_RSPCFG0					
0xA3	7	RSVD	R	0x0	See "BUCK1_RSPCFG0"
	6-4	BUCK4_RSPPUP	R/W	0x7	
	3	RSVD	R	0x0	
	2-0	BUCK4_RSPPDN	R/W	0x3	
BUCK4_EN_DLY					
0xA4	1-0	BUCK4_ENPIN_CFG	R/W	0x2	See "BUCK1_ENPIN_CFG"
	5-0	BUCK4_EN_DLY	R/W	0x0	See "BUCK1_EN_DLY"
BUCK4_SHUTDOWN_DLY					
0xA5	1-0	BUCK4_DVSPIN_CFG	R/W	0x2	See "BUCK1_DVSPIN_CFG"
	5-0	BUCK4_SHUTDOWN_DLY	R/W	0x0	See "BUCK1_SHUTDOWN_DLY"

11. Revision History

Rev.	Date	Description
3.01	Mar 5, 2020	Removed addendum. Updated Note 1 and corrected terminal finish classification.
3.00	Dec 13, 2019	Added Note 1 to Ordering Information table. Added Addendum to page 56.
2.00	Jul 8, 2019	Applied new formatting throughout document. Updated page 1 description. Updated Applications section on page 1. Updated Features section Updated Figures 1 and 2 on page 1. Updated Figures 3 and 4 on page 3. Updated Figure 5 on page 5. Updated Ordering Information table. Updated pin descriptions for GPIO0, GPIO1, GPIO2, MPIO0, MPIO1, MPIO2, and MPIO3. Updated I/O Pin Configuration section including tables. Updated Absolute Maximum Ratings table by breaking out the VOUT spec, added INT, MPIO, GPIO Pins to GND line, and removing MPIO and GPIO from the VIO, EN line. Updated Recommended Operation Conditions by adding INT, MPIO, GPIO Pins to GND line. Added TA = +25°C to the Analog Specification table heading. Removed the minimum spec for I2C Frequency Capability. Added two more rows to Buck Output Voltage Range on page 11. Added two more rows to Output Voltage Step Size on page 11. Added Note 8 and its cross-references. Updated graphic in Table 4 on page 13 Updated Figures 6 through 10 on page 15. Added Figures 11 through 16 on page 16. Updated Figures 21 and 22 on page 17. Updated Figures 27 through 31. Updated Inductor Selection section including table. Replaced Dynamic Voltage Scaling Sections including tables. Updated Notes in the Powering Sequencing section on page 25. Updated Note in the SPI Data Protocol section on page 31, under Read Operation paragraph. Updated Data Hold Time minimum specifications for all modes in Table 17 on page 36 changed from 0ns to 15ns and removed the Rise/Fall time minimum specifications of SCL and SDA for all I2C modes. Updated Figures 40, 41, 44, 45, 50, 51, 52, and 53. Updated Table 18 on page 39 (Microvia Structure description) Updated Register Address Map. Added missing registers 0x3B BUCK1_EA2, 0x3F BUCK1_CFG3, 0x54 BUCK1_RSPCFG1, 0x55 BUCK1_RSPCFG0, 0x56 BUCK1_EN_DLY, 0x57 BUCK1_SHUTDOWN_DLY, 0x58 BUCK2_EA2, 0x5C BUCK2_CFG3, 0x6E BUCK2_RSPCFG1, 0x6F BUCK2_RSPCFG0, 0x70 BUCK2_EN_DLY, 0x71 BUCK2_SHUTDOWN_DLY, 0x72 BUCK3_EA2, 0x76 BUCK3_CFG3, 0x88 BUCK3_RSPCFG1, 0x89 BUCK3_RSPCFG0, 0x8A BUCK3_EN_DLY, 0x8B BUCK3_SHUTDOWN_DLY, 0x8C BUCK4_EA2, 0x90 BUCK4_CFG3, 0xA2 BUCK4_RSPCFG1, 0xA3 BUCK4_RSPCFG0, 0xA4 BUCK4_EN_DLY, and 0xA5 BUCK4_SHUTDOWN_DLY, 0x23 IO_SPICFG, 0x3E BUCK1_DCM, 0x46 BUCK1_PHADD, 0x5B BUCK2_DCM, 0x5D BUCK2_CFG2, 0x75 BUCK3_DCM, 0x8F BUCK4_DCM to the Register Description by Address section. Updated descriptions for 0x48 BUCK1_DVS0CFG1, 0x54 BUCK1_RSPCFG1, 0x3FBUCK1_CFG3, 0x55 BUCK1_RSPCFG0 in the Register Descriptions by Address section. Removed About Intersil section. Updated disclaimer.
1.00	May 8, 2017	Updated Title to "Triple/Quad Output Power Management IC on page 1. Updated first paragraph to help differentiate the two parts. Updated ordering information table. Updated package dimension on page 1 Features bullet and in the ordering information table on page 6 to match what the POD states.
0.00	Feb 28, 2017	Initial release

12. Package Outline Drawing

For the most recent package outline drawing, see [W6x9.54](#).

W6x9.54
 54 BALL WAFER LEVEL CHIP SCALE PACKAGE (WLCSP 0.4mm PITCH)
 Rev 0, 10/15

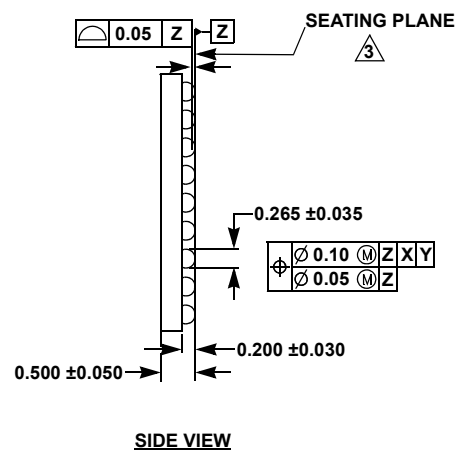
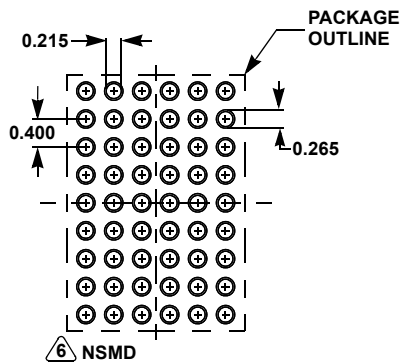
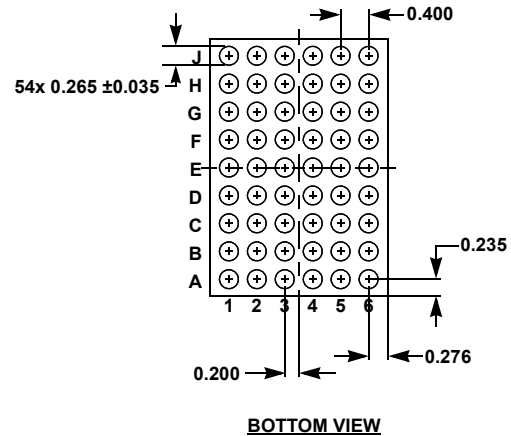
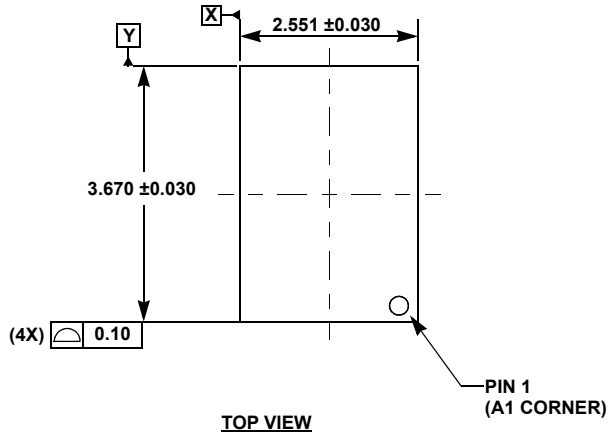

NOTES:

1. All dimensions are in millimeters.
2. Dimensions and tolerance per ASME Y 14.5M - 1994.
3. Primary datum Z and seating plane are defined by the spherical crowns of the bump.
4. Dimension is measured at the maximum bump diameter parallel to primary datum Z.
5. Bump position designation per JESD 95-1, SPP-010.
6. NSMD refers to non-solder mask defined pad design per TB451.

IMPORTANT NOTICE AND DISCLAIMER

RENESAS ELECTRONICS CORPORATION AND ITS SUBSIDIARIES (“RENESAS”) PROVIDES TECHNICAL SPECIFICATIONS AND RELIABILITY DATA (INCLUDING DATASHEETS), DESIGN RESOURCES (INCLUDING REFERENCE DESIGNS), APPLICATION OR OTHER DESIGN ADVICE, WEB TOOLS, SAFETY INFORMATION, AND OTHER RESOURCES “AS IS” AND WITH ALL FAULTS, AND DISCLAIMS ALL WARRANTIES, EXPRESS OR IMPLIED, INCLUDING, WITHOUT LIMITATION, ANY IMPLIED WARRANTIES OF MERCHANTABILITY, FITNESS FOR A PARTICULAR PURPOSE, OR NON-INFRINGEMENT OF THIRD PARTY INTELLECTUAL PROPERTY RIGHTS.

These resources are intended for developers skilled in the art designing with Renesas products. You are solely responsible for (1) selecting the appropriate products for your application, (2) designing, validating, and testing your application, and (3) ensuring your application meets applicable standards, and any other safety, security, or other requirements. These resources are subject to change without notice. Renesas grants you permission to use these resources only for development of an application that uses Renesas products. Other reproduction or use of these resources is strictly prohibited. No license is granted to any other Renesas intellectual property or to any third party intellectual property. Renesas disclaims responsibility for, and you will fully indemnify Renesas and its representatives against, any claims, damages, costs, losses, or liabilities arising out of your use of these resources. Renesas' products are provided only subject to Renesas' Terms and Conditions of Sale or other applicable terms agreed to in writing. No use of any Renesas resources expands or otherwise alters any applicable warranties or warranty disclaimers for these products.

(Rev.1.0 Mar 2020)

Corporate Headquarters

TOYOSU FORESIA, 3-2-24 Toyosu,
Koto-ku, Tokyo 135-0061, Japan
www.renesas.com

Contact Information

For further information on a product, technology, the most up-to-date version of a document, or your nearest sales office, please visit:
www.renesas.com/contact/

Trademarks

Renesas and the Renesas logo are trademarks of Renesas Electronics Corporation. All trademarks and registered trademarks are the property of their respective owners.