

AXC F IL ADAPT

PLCnext Technology,
Inline adapter terminal (INTERBUS master),
right-alignable

Data sheet
108629_en_00

© PHOENIX CONTACT 2018-10-05

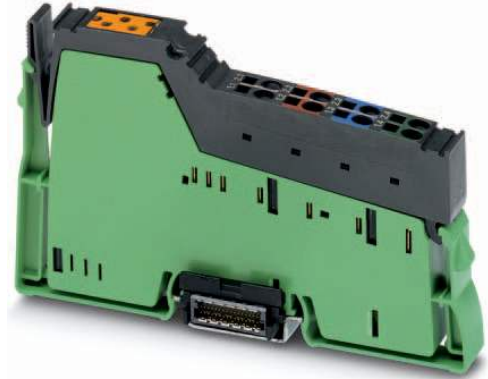

1 Description

The Inline adapter terminal (INTERBUS master) is designed to be aligned to the right of an AXC F ... PLCnext controller. The Inline adapter terminal can be used to set up a PLCnext Inline station and integrate INTERBUS devices.

Features

- Automatic detection of the transmission speed in INTERBUS (500 kbps or 2 Mbps)
- Up to 63 INTERBUS devices can be connected
- Diagnostic and status indicators



NOTE: Device defect due to impermissible firmware version

The Inline adapter terminal is designed to be aligned to the right of PLCnext controllers with specific firmware versions. If you align the Inline adapter terminal next to a PLCnext controller with a firmware version that is not permitted, this can cause a device defect to the PLCnext controller.

Make sure that the Inline adapter terminal is only aligned next to a PLCnext controller with a firmware version that is permitted.

AXC F ... PLCnext controllers with the following firmware versions are permitted:

- AXC F 2152 with firmware Version ≥ 1.2



Please note:

Align the Inline adapter terminal directly on the controller. Axioline F modules may not be aligned on the controller.



This data sheet is only valid in association with the Axioline F system manual and the user manual for the Axioline F controller being used.



Make sure you always use the latest documentation.
It can be downloaded at: phoenixcontact.net/product/1020304

2	Table of contents	
1	Description	1
2	Table of contents	2
3	Ordering data	3
4	Technical data	4
5	Module components	7
6	Internal circuit diagram	8
7	Design of a PLCnext Inline station	9
8	Mounting.....	10
	8.1 Removing the controller	10
	8.2 Mount bus base module	10
	8.3 Snapping on the controller	11
	8.4 Snapping on electronics modules	11
	8.5 Mount Inline connector.....	11
9	Connecting the supply voltage.....	12
10	Connection example.....	13
11	Diagnostics and status indicators	14
12	Supported INTERBUS master services	15
13	PCP communication	18

3 Ordering data

Description	Type	Order No.	Pcs./Pkt.
Right-alignable Inline adapter terminal (INTERBUS master) for a PLCnext controller for setting up a PLCnext Inline station	AXC F IL ADAPT	1020304	1
Documentation	Type	Order No.	Pcs./Pkt.
User manual, English, Axioline F: System and installation	UM EN AXL F SYS INST	-	-
User manual, English, Axioline F: Diagnostic registers, and error messages	UM EN AXL F SYS DIAG	-	-
User Manual, English, for diagnosis in Generation 4 controller boards	IBS SYS DIAG DSC UM E	2747293	1
User manual, English, for the Peripherals Communication Protocol (PCP), only available as a download.	IBS PCP UM E	2753931	1
User manual, English, for the Peripherals Communication Protocol (PCP), only available as a download.	IBS SYS PCP G4 UM E	2745169	1

4 Technical data

Dimensions (nominal sizes in mm)

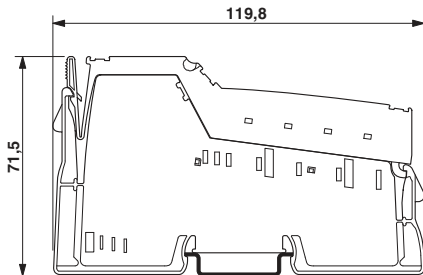

Width	12.2 mm
Height	119.8 mm
Depth	71.5 mm

General data

Weight	66 g
Ambient temperature (operation)	-25 °C ... 55 °C
Ambient temperature (storage/transport)	-40 °C ... 85 °C
Permissible humidity (operation)	10 % ... 95 % (non-condensing)
Permissible humidity (storage/transport)	10 % ... 95 % (non-condensing)
Air pressure (operation)	70 kPa ... 106 kPa (up to 3000 m above sea level)
Air pressure (storage/transport)	10 kPa ... 106 kPa (up to 3000 m above sea level)
Degree of protection	IP20
Mounting type	DIN rail mounting

Connection data: Inline connector

Connection method	Spring-cage connection
Conductor cross section solid / stranded	0.08 mm ² ... 1.5 mm ² / 0.08 mm ² ... 1.5 mm ²
Conductor cross section [AWG]	28 ... 16
Stripping length	8 mm

System limits

Amount of process data	max. 4096 Bit (INTERBUS)
Number of local bus devices that can be connected	max. 63 (observe current consumption)
Number of devices with parameter channel	max. 62

24 V supply U_{ILC}

Supply voltage	24 V DC -15 % / +20 % (acc. to EN 61131-2)
Current draw	20 mA

7.5 V communications power U_L (potential jumper)

Supply voltage	7.5 V DC $\pm 5\%$
Power supply unit	max. 0.8 A DC (observe derating)

24 V analog supply U_{ANA} (potential jumper)

Supply voltage	24 V DC -15 % / +20 %
Supply voltage range	19.2 V DC ... 30 V DC (including all tolerances, including ripple)
Power supply unit	0.5 A DC (observe derating)

24 V main supply U_M

Supply voltage	24 V DC -15 % / +20 % (acc. to EN 61131-2)
Supply voltage range	19.2 V DC ... 30 V DC (including all tolerances, including ripple)
Power supply unit	max. 8 A DC (sum of $U_M + U_S$)

24 V segment supply U_S

Supply voltage	24 V DC -15 % / +20 % (in accordance with EN 61131)
Supply voltage range	19.2 V DC ... 30 V DC (including all tolerances, including ripple)
Power supply unit	max. 8 A (sum of $U_M + U_S$)

Protective circuit

Polarity reversal protection of the supply voltage	Polarity protection diode
Transient protection	Suppressor diode

Protection



NOTE: Damage to the electronics

Provide external protection for the module to protect it against polarity reversal. The power supply unit and the external fuse must be coordinated so that safe tripping is ensured in the event of an error.

Error messages to the higher level control or computer system

Bus error in INTERBUS	Yes
Peripheral fault in INTERBUS	Yes

Mechanical tests

Shock in acc. with EN 60068-2-27/IEC 60068-2-27	30g, 11 ms period, half-sine shock pulse
Continuous shock according to EN 60068-2-27/ IEC 60068-2-27	10g
Vibration resistance in acc. with EN 60068-2-6/ IEC 60068-2-6	2g

Conformance with EMC Directive 2014/30/EU

Noise immunity test in accordance with EN 61000-6-2

EN 61000-4-2 (ESD) Electrostatic discharge (ESD) EN 61000-4-2/ IEC 61000-4-2	Criterion B, 4 kV contact discharge, 8 kV air discharge
EN 61000-4-3 (electromagnetic fields) Electromagnetic fields EN 61000-4-3/IEC 61000-4-3	Criterion A, Field intensity: 10 V/m
EN 61000-4-4 Fast transients (burst) EN 61000-4-4/IEC 61000-4-4	Criterion B, 2 kV

Conformance with EMC Directive 2014/30/EU

EN 61000-4-5 (surge)	Criterion B, DC supply lines: ± 0.5 kV/ ± 0.5 kV (symmetrical/asymmetrical)
Transient overvoltage (surge) EN 61000-4-5/ IEC 61000-4-5	

EN 61000-4-6 (line noise immunity)	Criterion A; Test voltage 10 V
Conducted interference EN 61000-4-6/IEC 61000-4-6	

Noise emission test as per EN 61000-6-4	Class A
--	---------

Approvals

For the latest approvals, please visit phoenixcontact.net/products.

5 Module components

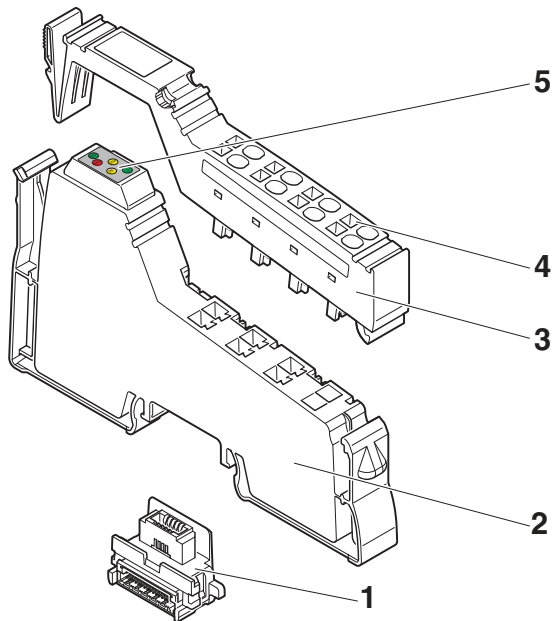

Figure 1 Module components

- 1 Bus base module
- 2 Electronics module
- 3 Inline connector
- 4 Terminal points
- 5 Diagnostic and status indicators

6 Internal circuit diagram

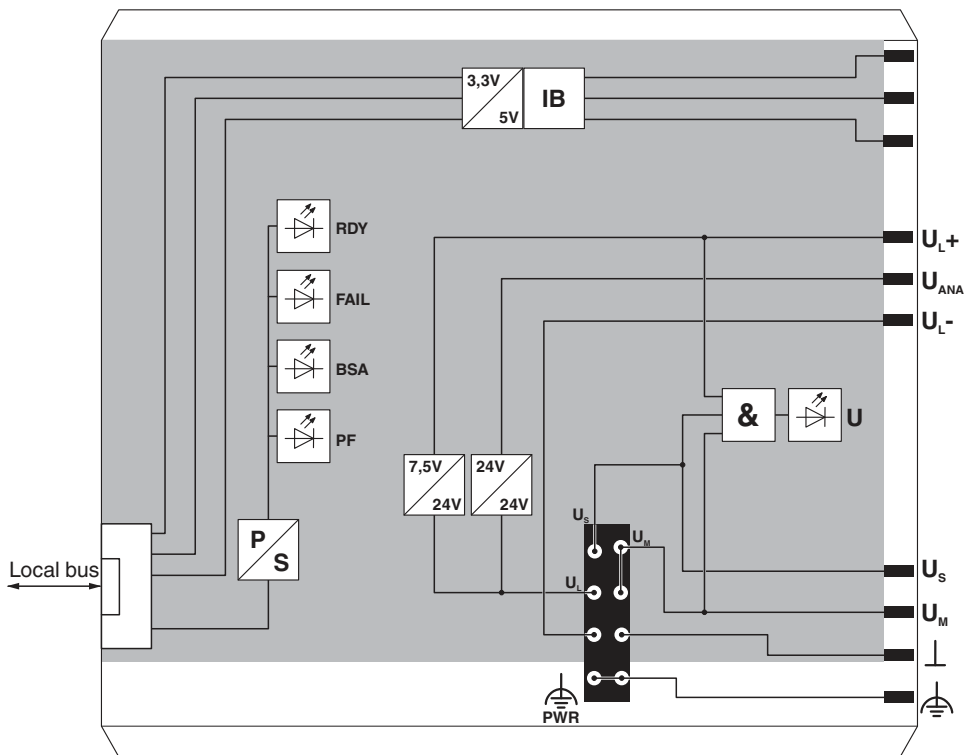

Figure 2 Basic circuit diagram

Key:

- | | |
|--|-------------------------------|
| | Power supply unit |
| | Protocol chip |
| | LED |
| | AND gates |
| | Parallel-to-serial converters |

7 Design of a PLCnext Inline station

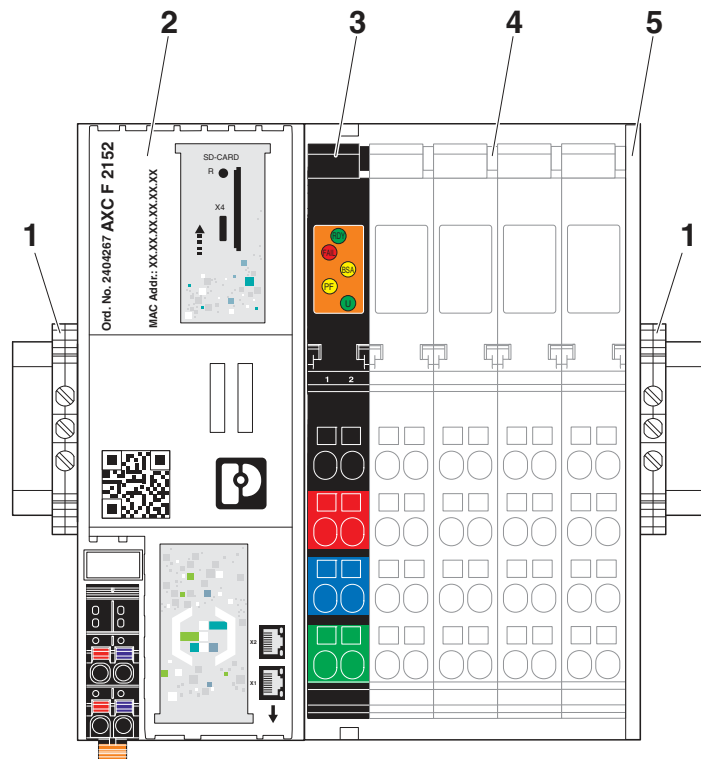

Figure 3 Design of a PLCnext Inline station

- 1 End clamp (e.g., CLIPFIX 35-5, Order No. 3022276)
- 2 PLCnext controller for Axioline F (in the example: AXC F 2152)
- 3 Inline adapter terminal
- 4 Inline terminals corresponding to the application
- 5 End plate (snap onto the DIN rail as station end)

8 Mounting



Please note:

On a controller for Axioline F, only **one** Inline adapter terminal may be aligned to the right.



Please note:

Mount all the necessary modules **before** supplying power to the PLCnext Inline station. Modules to which power is only supplied following the controller boot process are not detected or may result in a malfunction. To ensure that the Inline adapter terminal is detected correctly, proceed as follows:

- Switch on the power to the Inline adapter terminal **before** switching on the power to the controller
- or
- Switch on the power to the Inline adapter terminal and the controller **simultaneously**.



NOTE: Device defect due to impermissible firmware version

The Inline adapter terminal is designed to be aligned to the right of PLCnext controllers with specific firmware versions. If you align the Inline adapter terminal next to a PLCnext controller with a firmware version that is not permitted, this can cause a device defect to the PLCnext controller.

Make sure that the Inline adapter terminal is only aligned next to a PLCnext controller with a firmware version that is permitted.

AXC F ... PLCnext controllers with the following firmware versions are permitted:

- AXC F 2152 with firmware Version ≥ 1.2

8.1 Removing the controller

The controller must be removed in order to mount the bus base module of the Inline adapter terminal.

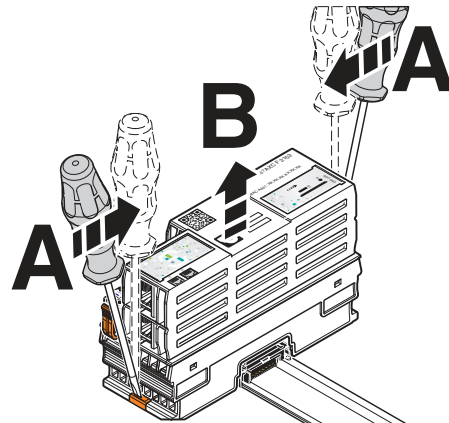

Figure 4 Removing the controller

- Insert a suitable tool (e.g., bladed screwdriver) into the upper and lower snap-on mechanisms (base latches) of the controller one after the other and release it (A). The base latches are latched in place in the open position.
- Remove the controller perpendicular to the DIN rail (B).

8.2 Mount bus base module

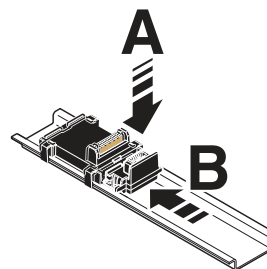

Figure 5 Mounting the bus base module

- Place the bus base module of the Inline adapter terminal on the DIN rail (A).
- Push the bus base module of the Inline adapter terminal into the connection of the bus base module on the controller (B).



Please note:

Align the Inline adapter terminal directly on the controller. Axioline F modules may not be aligned on the controller.

8.3 Snapping on the controller

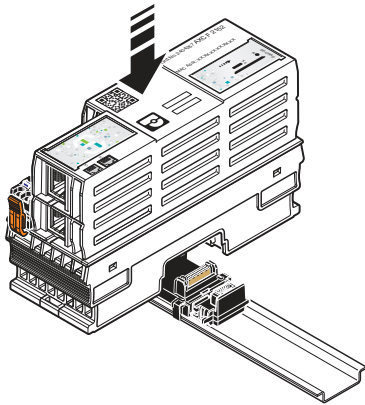

Figure 6 Snapping on the controller

- Place the controller vertically on the first bus base module and the DIN rail until it snaps into place with a click.
- Make sure that the device connector for the bus base connection is situated above the corresponding socket on the bus base module.

8.4 Snapping on electronics modules

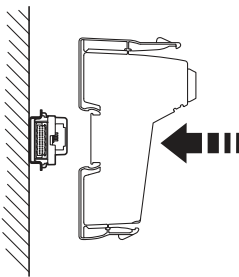

Figure 7 Snapping on the electronics module of the Inline adapter terminal

- Place the electronics module of the Inline adapter terminal vertically on the corresponding bus base module and on the DIN rail until it snaps into place with a click.
- Make sure that the device connector for the bus base connection is situated above the corresponding socket on the bus base module.
- Mount the electronics modules of all necessary Inline terminals. Note the assembly instructions in the device-specific packing slip.

8.5 Mount Inline connector

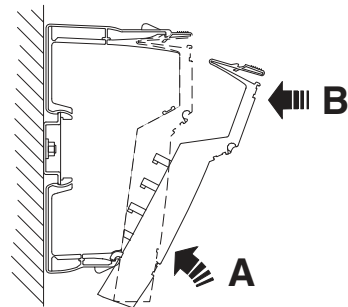

Figure 8 Insert Inline connector

- Insert the Inline connectors in the specified order (A, B).

9 Connecting the supply voltage



NOTE: Device defect due to impermissible firmware version

The Inline adapter terminal is designed to be aligned to the right of PLCnext controllers with specific firmware versions. If you align the Inline adapter terminal next to a PLCnext controller with a firmware version that is not permitted, this can cause a device defect to the PLCnext controller.

Make sure that the Inline adapter terminal is only aligned next to a PLCnext controller with a firmware version that is permitted.

AXC F ... PLCnext controllers with the following firmware versions are permitted:

- AXC F 2152 with firmware Version ≥ 1.2

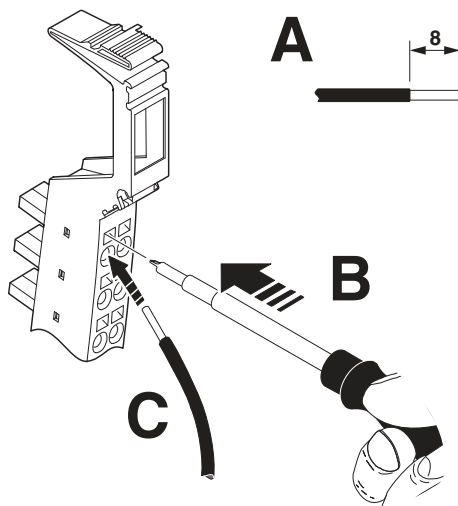

Figure 9 Connecting cables

- Strip 8 mm off the cables.
- Release the spring by pressing with the screwdriver.
- Insert the cable into the terminal point.
- Secure the cable by removing the screwdriver.

Recommended: flat-bladed screwdriver with blade dimensions of 0.6 mm x 3.5 mm x 100 mm (e. g., SZF 1-0,6X3,5, Order No. 1204517)

Terminal point assignment

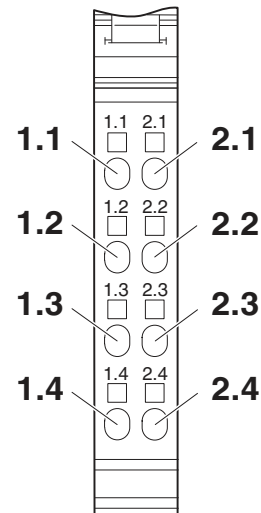

Figure 10 Terminal point assignment

Terminal point	Assignment
1.1	U_S (24 V DC)
1.2	U_{ILC} (24 V DC)
1.3	GND U_{ILC}
1.4	FE
2.1	U_M (24 V DC)
2.2	U_M (24 V DC)
2.3	GND U_M/U_S
2.4	FE

Key:

- U_S (24 V DC) 24 V supply for segment circuit
- U_M (24 V DC) 24 V supply for main circuit
- U_{ILC} (24 V DC) 24 V main voltage / 7.5 V logic supply / 24 V analog supply
- GND Ground
- FE Functional earth ground

10 Connection example

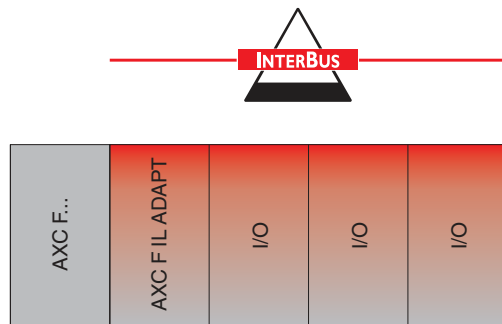

Figure 11 Connection example

Key:

AXC F ...	AXC F ... PLCnext controller
AXC F IL ADAPT	Inline adapter terminal
I/O	Inline terminals corresponding to your application
INTERBUS	INTERBUS devices according to your application

11 Diagnostics and status indicators

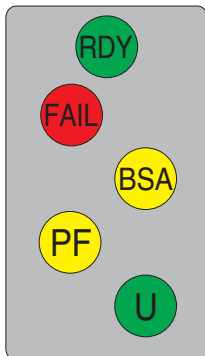

Figure 12 Diagnostic and status indicators

Designation	Color	Meaning	State	Description
RDY	Green	INTERBUS master	On	INTERBUS master in the RUN state
			Flashing	INTERBUS master in the READY or ACTIVE state
			OFF	INTERBUS master is not ready to operate
FAIL	Red	Error	On	Bus, controller or user error
			OFF	No error
BSA	Yellow	Bus segment	On	At least one bus segment aborted
			OFF	No bus segment aborted
PF	Yellow	Peripheral fault	On	Peripheral fault on at least one device in INTERBUS
			OFF	No peripheral fault
U	Green	Supply voltages U_S , U_M , U_L	On	Supply voltages U_S , U_M , U_L present
			OFF	At least one of the supply voltages U_S , U_M or U_L is not present

12 Supported INTERBUS master services



For more detailed information on the INTERBUS G4 services, please refer to the IBS SYS FW G4 UM E user manual. The user manual can be downloaded at phoenixcontact.net/products.



The following restrictions apply for the INTERBUS master:

- Support for INTERBUS devices with slave protocol chip SUP13 or higher
- No FO diagnostics
- No single-channel diagnostics
- No support for LPC1 or LPC2
- No isolated disconnection possible

Firmware services are used to carry out the configuration, parameterization, and diagnostics of INTERBUS.

The Inline adapter terminal (INTERBUS master) supports the following INTERBUS G4 services (some of which have a limited scope of functions):

Code (hex)	Service	Description
0306	Initiate_Load_Configuration	Create configuration frame for data transmission
		<ul style="list-style-type: none"> - Max. 127 characters - Can only be set when New_Config = 1
0307	Load_Configuration	Transmit the device data for a configuration
		Used_Attributes: Bit 0: device number Bit 1: device code Bit 2: reserved Bit 3: device level Bit 4: logical group number (always FFFF _{hex}) Bits 5 ... 13: reserved Bit 14: extended device information Bit 15: reserved
0308	Terminate_Load_Configuration	Terminate the transmission of configuration data (only for automatic parameterization)
		Default_Parameter: The PCP channel is always parameterized automatically. The process data channel is only parameterized automatically if bit 0 is set.
0309	Read_Configuration	Read various entries of the configuration directory
		Used_Attributes: Bit 0: device number Bit 1: device code Bit 2: reserved Bit 3: device level Bit 4: logical group number Bits 5 ... 7: reserved Bit 8: global_bus_error Bit 9: separate_bus_error (Reconf and Watchdog not supported) Bit 10: device status Bits 11 ... 13: reserved Bit 14: extended device information Bit 15: reserved

Code (hex)	Service	Description
030A	Complete_Load_Configuration	Transmit all the device data for a configuration Used_Attributes: Bit 0: device number Bit 1: device code Bit 2: reserved Bit 3: device level Bit 4: logical group number (always FFFF _{hex}) Bits 5 ... 13: reserved Bit 14: extended device information Bit 15: reserved
030B	Complete_Read_Configuration	Read all the device data for a configuration Used_Attributes: Bit 0: device number Bit 1: device code Bit 2: reserved Bit 3: device level Bit 4: logical group number (always FFFF _{hex}) Bits 5 ... 13: reserved Bit 14: extended device information Bit 15: reserved
030C	Delete_Configuration	Delete inactive configuration frames from the configuration directory
030E	Control_Parameterization	Start or end the parameterization phase
030F	Control_Statistics	Control statistical diagnostics
0314	Control_Device_Function_Not_Exclusive	Send control commands to local bus device Device_Function: 0003 _{hex} : Conf_Dev_Err 0004 _{hex} : Conf_Dev_Err_All
0315	Read_Device_State	Read status of local bus devices Device_State_Mask: Bits 0 ... 10: reserved Bit 11: peripheral fault Bits 12 ... 15: reserved
0316	Get_Error_Info	Request additional error information
0328	Compact_Load_Process_Data_Reference_List	Configure controller board without software support - Permitted addresses: 0000 _{hex} ... 03FF _{hex} - No overlapping or duplication possible - Modules up to max. 8 bits with Byte-Cons at every address, modules > 8 bits only at even addresses
0329	Compact_Read_Process_Data_Reference_List	Read address lists of the control or computer system that were configured using the "Compact_Load_Process_Data_Reference_List" service (3028 _{hex})
032A	Get_Version_Info	Read version information
032B	Get_Diag_Info	Read local bus counter
0351	Read_Value	Read system parameter Supported values for the Variable_ID parameter: see next table
0701	Start_Data_Transfer	Start data transfer
0702	Stop_Data_Transfer	Stop data transfer

Code (hex)	Service	Description
0710	Create_Configuration	Read the connected bus
0711	Activate_Configuration	Check the configuration frame matches the connected bus and whether addresses overlap
0712	Deactivate_Configuration	Deactivate configuration frame
0713	Control_Active_Configuration	Switch INTERBUS device on or off. Only Switch_Codes 0004 _{hex} (Device_Disable) and 0005 _{hex} (Device_Enable) are supported. Switching or bridging has no influence on the position of the process data in the memory or the CR assignment of the PCP devices.
0714	Control_Device_Function	Send control commands to local bus device Device_Function: 0003 _{hex} : Conf_Dev_Err 0004 _{hex} : Conf_Dev_Err_All
0750	Set_Value	Assign new values to system parameters Supported values for the Variable_ID parameter: see next table
0760	Confirm_Diagnostics	Update diagnostic display and diagnostic register
1303	Alarm_Stop	Reset local bus

Supported values for the Variable_ID parameter

Variable_ID (hex)	System parameter	Value/note
0101	State of the system management	Read access only
0104	Contents of the diagnostic status register	Read access only
0105	Contents of the diagnostic parameter register	Read access only
010D	Contents of the extended diagnostic parameter register	Read access only
2200	Operating mode	0000 0000 _{hex} : asynchronous 0600 0000 _{hex} : asynchronous with synchronization pulse
2204	Control the behavior of the input data in the event of a bus error	0: input data in the MPM is frozen (default setting) 1: input data in the MPM is set to zero
2210	Specified process data cycle time in μ s (32-bit value)	Permissible value range: 0000 0000 _{hex} : off 0000 0100 _{hex} ... 0001 FB00 _{hex}
2211	Bus timeout in μ s (32-bit value) Default setting: 200 ms	Permissible value: 0000 0000 _{hex} : (default setting)
2212	Bus warning time in μ s (32-bit value) Default setting: 0 (not activated)	Permissible value range: 0000 00100 _{hex} ... 000F FF00 _{hex}
2216	Actual process data cycle time in μ s (32-bit value)	Read access only
2218	Data cycle time in μ s (32-bit value)	Read access only
A228	Read baud rate	Read access only 0: 2 Mbaud 1: 500 kBaud

13 PCP communication

The Inline adapter terminal (INTERBUS master) supports the Peripherals Communication Protocol (PCP) Version 2.0 with Peripherals Message Specification (PMS).

Peripherals Network Management 7 (PNM7) services are not supported.



For information on PCP communication, please refer to the PCP user manuals (see Ordering data).

Code (hex)	Service
0081	Read_Request
4081	Read_Indication
C081	Read_Response
8081	Read_Confirmation
0082	Write_Request
4082	Write_Indication
C082	Write_Response
8082	Write_Confirmation
0885	Information_Report_Request
4885	Information_Report_Indication
0086	Status_Request
8086	Status_Confirmation
0087	Identify_Request
8087	Identify_Confirmation
008B	Initiate_Request
408B	Initiate_Indication
C08B	Initiate_Response
808B	Initiate_Confirmation
088D	Abort_Request
488D	Abort_Indication
488E	Reject_Indication
0264	Load_CRL_Attribute_Loc_Request
8264	Load_CRL_Attribute_Loc_Confirmation