

μA9636A RS-423 Dual Programmable Slew Rate Line Driver

Linear Division Interface Products

Description

The μA9636A is a TTL/CMOS compatible, dual, single ended line driver which has been specifically designed to satisfy the requirements of EIA Standard RS-423.

The μA9636A is suitable for use in digital data transmission systems where signal wave shaping is desired. The output slew rates are jointly controlled by a single external resistor connected between the wave shaping control lead (WS) and ground. This eliminates any need for external filtering of the output signals. Output voltage levels and slew rates are independent of power supply variations. Current-limiting is provided in both output states. The μA9636A is designed for nominal power supplies of ± 12 V.

Inputs are TTL compatible with input current loading low enough (1/10 UL) to be also compatible with CMOS logic. Clamp diodes are provided on the inputs to limit transients below ground.

- Programmable Slew Rate Limiting
- Meets EIA Standard RS-423
- Commercial Or Extended Temperature Range
- Output Short Circuit Protection
- TTL And CMOS Compatible Inputs

Absolute Maximum Ratings

Storage Temperature Range	
Ceramic DIP	-65°C to +175°C
Molded DIP	-65°C to +150°C
Operating Temperature Range	
Extended (μA9636AM)	-55°C to +125°C
Commercial (μA9636AC)	0°C to +70°C
Lead Temperature	
Ceramic DIP (soldering, 60 s)	300°C
Molded DIP (soldering, 10 s)	265°C
Internal Power Dissipation ^{1,2}	
8L-Ceramic DIP	1.30 W
8L-Molded DIP	0.93 W
V+ Lead Potential to Ground Lead	V- to +15 V
V- Lead Potential to Ground Lead	+0.5 V to -15 V
V+ Lead Potential to V- Lead	0 V to +30 V
Output Potential to Ground Lead	± 15 V
Output Source Current	-150 mA
Output Sink Current	150 mA

Notes

1. T_{J Max} = 175°C for the Ceramic DIP, and 150°C for the Molded DIP.
2. Ratings apply to ambient temperature at 25°C. Above this temperature, derate the 8L-Ceramic DIP at 8.7 mW/°C, and the 8L-Molded DIP at 7.5 mW/°C.

Connection Diagram 8-Lead DIP (Top View)

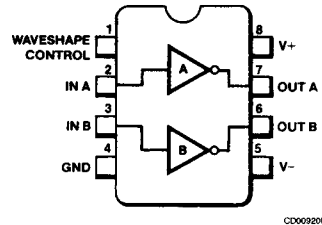

CD00220F

Order Information

Device Code	Package Code	Package Description
μA9636ARM	6T	Ceramic DIP
μA9636ARC	6T	Ceramic DIP
μA9636ATC	9T	Molded DIP

Equivalent Circuit

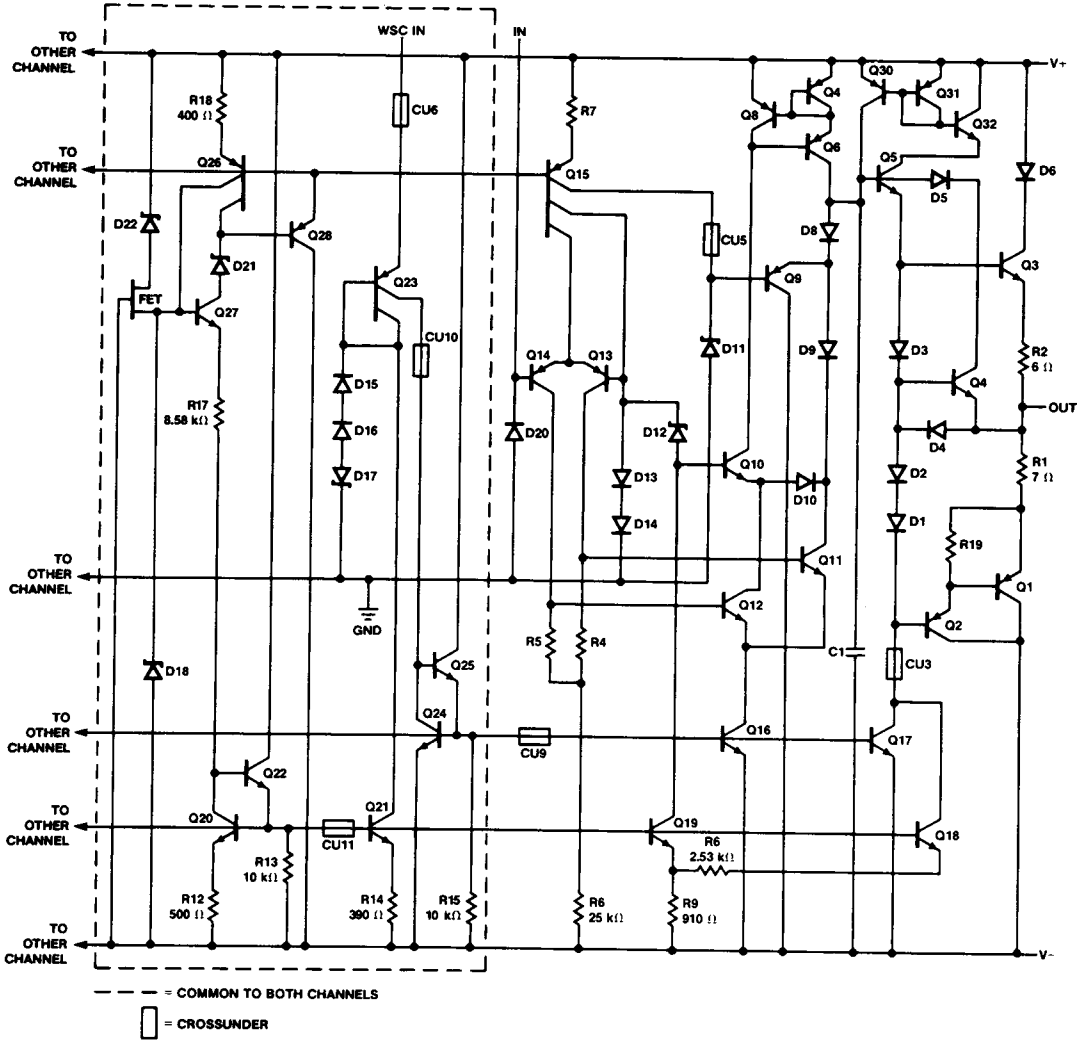

EQ00300F

μA9636A

Recommended Operating Conditions

Symbol	Characteristic	μA9636A			μA9636AC			Unit
		Min	Typ	Max	Min	Typ	Max	
V+	Positive Supply Voltage	10.8	12	13.2	10.8	12	13.2	V
V-	Negative Supply Voltage	-13.2	-12	-10.8	-13.2	-12	-10.8	V
T _A	Operating Temperature	-55	25	125	0	25	70	°C
R _{WS}	Wave Shaping Resistance	10		500	10		1000	kΩ

μA9636A

Electrical Characteristics Over recommended operating temperature, supply voltage and wave shaping resistance ranges unless otherwise specified.

DC Characteristics

Symbol	Characteristic	Condition	Min	Typ	Max	Unit
V _{OH1}	Output Voltage HIGH	R _L to GND (R _L = ∞)	5.0	5.6	6.0	V
V _{OH2}		R _L to GND (R _L = 3.0 kΩ)	5.0	5.6	6.0	V
V _{OH3}		R _L to GND (R _L = 450 Ω)	4.0	5.5	6.0	V
V _{OL1}	Output Voltage LOW	R _L to GND (R _L = ∞)	-6.0	-5.7	-5.0	V
V _{OL2}		R _L to GND (R _L = 3.0 kΩ)	-6.0	-5.6	-5.0	V
V _{OL3}		R _L to GND (R _L = 450 Ω)	-6.0	-5.4	-4.0	V
R _O	Output Resistance	450 Ω ≤ R _L		25	50	Ω
I _{OS+}	Output Short Circuit Current ¹	V _O = 0 V, V _I = 0 V	-150	-60	-15	mA
I _{OS-}		V _O = 0 V, V _I = 2.0 V	15	60	150	mA
I _{CEX}	Output Leakage Current	V _O = ±6.0 V, Power-Off	-100		+100	μA
V _{IH}	Input Voltage HIGH		2.0			V
V _{IL}	Input Voltage LOW				0.8	V
V _{IC}	Input Clamp Diode Voltage	I _I = 15 mA	-1.5	-1.1		V
I _{IL}	Input Current LOW	V _I = 0.4 V	-80	-16		μA
I _{IH}	Input Current HIGH	V _I = 2.4 V		1.0	10	μA
		V _I = 5.5 V		10	100	
I+	Positive Supply Current	V _{CC} = ±12 V, R _L = ∞, R _{WS} = 100 kΩ, V _I = 0 V		13	18	mA
I-	Negative Supply Current	V _{CC} = ±12 V, R _L = ∞, R _{WS} = 100 kΩ, V _I = 0 V	-18	-13		mA

Notes

1. Only one output should be shorted at a time.

μA9636A (Cont.)

Electrical Characteristics Over recommended operating temperature, supply voltage and wave shaping resistance ranges unless otherwise specified.

AC Characteristics $V_{CC} = \pm 12\text{ V} \pm 10\%$, $T_A = 25^\circ\text{C}$, see AC Test Circuit

Symbol	Characteristic	Condition	Min	Typ	Max	Unit
t_r	Rise Time	$R_{WS} = 10\text{ k}\Omega$	0.8	1.1	1.4	μs
		$R_{WS} = 100\text{ k}\Omega$	8.0	11	14	
		$R_{WS} = 500\text{ k}\Omega$	40	55	70	
		$R_{WS} = 1000\text{ k}\Omega$	80	110	140	
t_f	Fall Time	$R_{WS} = 10\text{ k}\Omega$	0.8	1.1	1.4	μs
		$R_{WS} = 100\text{ k}\Omega$	8.0	11	14	
		$R_{WS} = 500\text{ k}\Omega$	40	55	70	
		$R_{WS} = 1000\text{ k}\Omega$	80	110	140	

Typical Performance Curves

Input/Output Transfer Characteristic vs Temperature

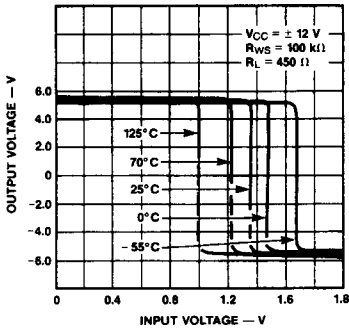

PC06091F

Input Current vs Input Voltage

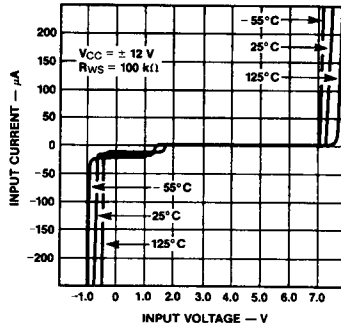

PC06081F

Output Current vs Output Voltage (Power On)

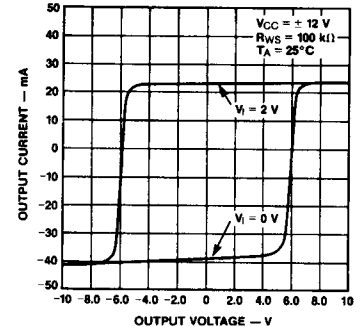

PC06101F

Output Current vs Output Voltage (Power Off)

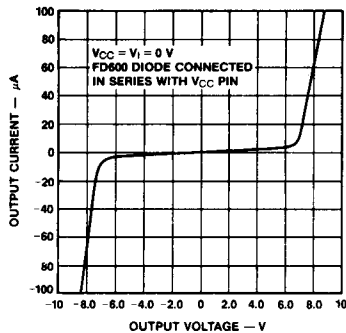

PC06111F

Supply Current vs Temperature

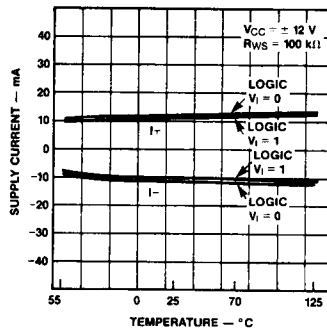

PC06121F

Transition Time vs Rws

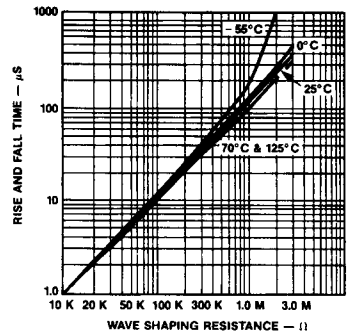

PC06131F

AC Test Circuit and Waveforms

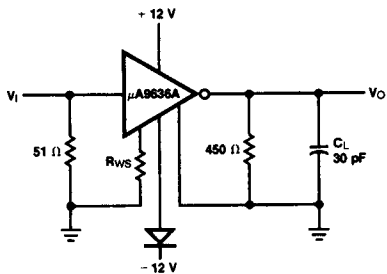

CR01791F

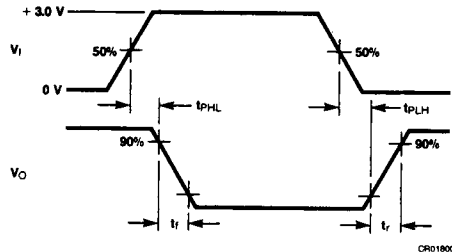

CR01800F

Vi
Amplitude: 3.0 V
Offset: 0 V
Pulse Width: 500 μs
PRR: 1.0 kHz
tr = tf ≤ 10 ns

Note
CL includes jig and probe capacitance

RS-423 System Application

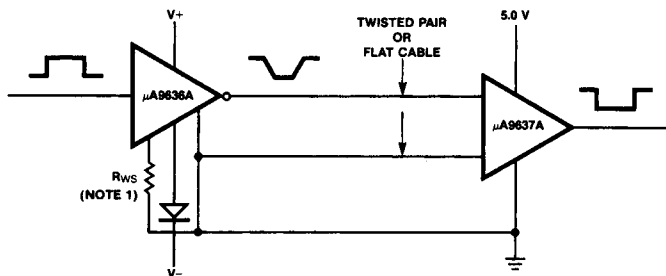

EG00290F

Note
1. Use Fairchild's 1N4448.