



# CY7C107B CY7C1007B

## 1M x 1 Static RAM

### Features

- High speed  
—  $t_{AA} = 12 \text{ ns}$
- CMOS for optimum speed/power
- Automatic power-down when deselected
- TTL-compatible inputs and outputs

### Functional Description

The CY7C107B and CY7C1007B are high-performance CMOS static RAMs organized as 1,048,576 words by 1 bit. Easy memory expansion is provided by an active LOW Chip Enable ( $\overline{CE}$ ) and three-state drivers. These devices have an automatic power-down feature that reduces power consumption by more than 65% when deselected.

Writing to the devices is accomplished by taking Chip Enable ( $\overline{CE}$ ) and Write Enable ( $\overline{WE}$ ) inputs LOW. Data on the input pin ( $D_{IN}$ ) is written into the memory location specified on the address pins ( $A_0$  through  $A_{19}$ ).

Reading from the devices is accomplished by taking Chip Enable ( $\overline{CE}$ ) LOW while Write Enable ( $\overline{WE}$ ) remains HIGH. Under these conditions, the contents of the memory location specified by the address pins will appear on the data output ( $D_{OUT}$ ) pin.

The output pin ( $D_{OUT}$ ) is placed in a high-impedance state when the device is deselected ( $\overline{CE}$  HIGH) or during a write operation ( $\overline{CE}$  and  $\overline{WE}$  LOW).

The CY7C107B is available in a standard 400-mil-wide SOJ; the CY7C1007B is available in a standard 300-mil-wide SOJ.

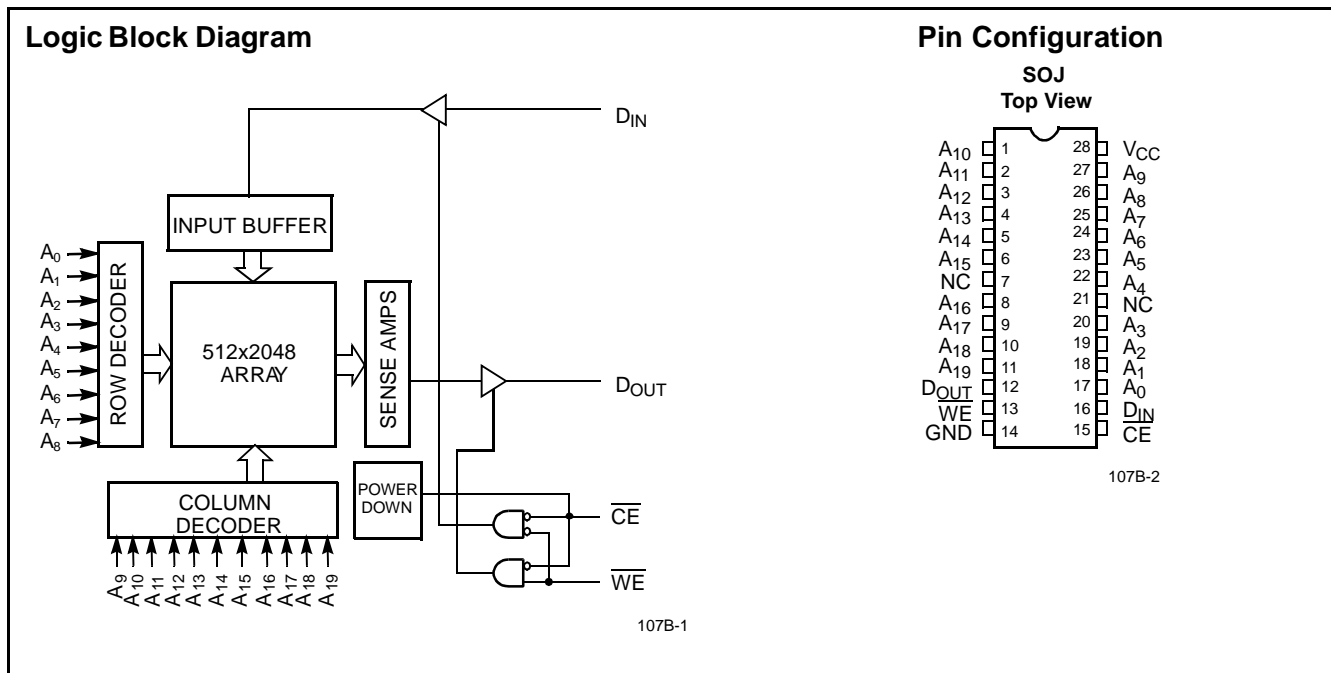

### Selection Guide

	7C107B-12 7C1007B-12	7C107B-15 7C1007B-15	7C107B-20 7C1007B-20	7C107B-25 7C1007B-25	7C107B-35 7C1007B-35
Maximum Access Time (ns)	12	15	20	25	35
Maximum Operating Current (mA)	90	80	75	70	60
Maximum CMOS Standby Current SB2 (mA)	2	2	2	2	2



**Maximum Ratings**

(Above which the useful life may be impaired. For user guidelines, not tested.)

Storage Temperature ..... -65°C to +150°C  
 Ambient Temperature with Power Applied..... -55°C to +125°C  
 Supply Voltage on V<sub>CC</sub> Relative to GND<sup>[1]</sup> ..... -0.5V to +7.0V  
 DC Voltage Applied to Outputs in High Z State<sup>[1]</sup> ..... -0.5V to V<sub>CC</sub> + 0.5V  
 DC Input Voltage<sup>[1]</sup>..... -0.5V to V<sub>CC</sub> + 0.5V

Current into Outputs (LOW) ..... 20 mA  
 Static Discharge Voltage ..... >2001V (per MIL-STD-883, Method 3015)  
 Latch-Up Current..... >200 mA

**Operating Range**

Range	Ambient Temperature <sup>[2]</sup>	V <sub>CC</sub>
Commercial	0°C to +70°C	5V ± 10%
Industrial	-40°C to +85°C	5V ± 10%

**Electrical Characteristics** Over the Operating Range

Parameter	Description	Test Conditions	7C107B-12 7C1007B-12		7C107B-15 7C1007B-15		7C107B-20 7C1007B-20		Unit
			Min.	Max.	Min.	Max.	Min.	Max.	
V <sub>OH</sub>	Output HIGH Voltage	V <sub>CC</sub> = Min., I <sub>OH</sub> = -4.0 mA	2.4		2.4		2.4		V
V <sub>OL</sub>	Output LOW Voltage	V <sub>CC</sub> = Min., I <sub>OL</sub> = 8.0 mA		0.4		0.4		0.4	V
V <sub>IH</sub>	Input HIGH Voltage		2.2	V <sub>CC</sub> +0.3	2.2	V <sub>CC</sub> +0.3	2.2	V <sub>CC</sub> +0.3	V
V <sub>IL</sub>	Input LOW Voltage <sup>[1]</sup>		-0.3	0.8	-0.3	0.8	-0.3	0.8	V
I <sub>IX</sub>	Input Load Current	GND ≤ V <sub>I</sub> ≤ V <sub>CC</sub>	-1	+1	-1	+1	-1	+1	μA
I <sub>OZ</sub>	Output Leakage Current	GND ≤ V <sub>I</sub> ≤ V <sub>CC</sub> , Output Disabled	-5	+5	-5	+5	-5	+5	μA
I <sub>OS</sub>	Output Short Circuit Current <sup>[3]</sup>	V <sub>CC</sub> = Max., V <sub>OUT</sub> = GND		-300		-300		-300	mA
I <sub>CC</sub>	V <sub>CC</sub> Operating Supply Current	V <sub>CC</sub> = Max., I <sub>OUT</sub> = 0 mA, f = f <sub>MAX</sub> = 1/t <sub>RC</sub>		90		80		75	mA
I <sub>SB1</sub>	Automatic $\overline{CE}$ Power-Down Current— TTL Inputs	Max. V <sub>CC</sub> , $\overline{CE} \geq V_{IH}$ , V <sub>IN</sub> ≥ V <sub>IH</sub> or V <sub>IN</sub> ≤ V <sub>IL</sub> , f = f <sub>MAX</sub>		20		20		20	mA
I <sub>SB2</sub>	Automatic $\overline{CE}$ Power-Down Current— CMOS Inputs	Max. V <sub>CC</sub> , $\overline{CE} \geq V_{CC} - 0.3V$ , V <sub>IN</sub> ≥ V <sub>CC</sub> - 0.3V or V <sub>IN</sub> ≤ 0.3V, f = 0		2		2		2	mA

**Notes:**

- V<sub>IL</sub> (min.) = -2.0V for pulse durations of less than 20 ns.
- T<sub>A</sub> is the "Instant On" case temperature.
- Not more than 1 output should be shorted at one time. Duration of the short circuit should not exceed 30 seconds.

**Electrical Characteristics** Over the Operating Range (continued)

Parameter	Description	Test Conditions	7C107B-25 7C1007B-25		7C107B-35 7C1007B-35		Unit
			Min.	Max.	Min.	Max.	
$V_{OH}$	Output HIGH Voltage	$V_{CC} = \text{Min.}, I_{OH} = -4.0 \text{ mA}$	2.4		2.4		V
$V_{OL}$	Output LOW Voltage	$V_{CC} = \text{Min.}, I_{OL} = 8.0 \text{ mA}$		0.4		0.4	V
$V_{IH}$	Input HIGH Voltage		2.2	$V_{CC} + 0.3$	2.2	$V_{CC} + 0.3$	V
$V_{IL}$	Input LOW Voltage <sup>[1]</sup>		-0.3	0.8	-0.3	0.8	V
$I_{IX}$	Input Load Current	$GND \leq V_I \leq V_{CC}$	-1	+1	-1	+1	$\mu\text{A}$
$I_{OZ}$	Output Leakage Current	$GND \leq V_I \leq V_{CC}$ , Output Disabled	-5	+5	-5	+5	$\mu\text{A}$
$I_{OS}$	Output Short Circuit Current <sup>[3]</sup>	$V_{CC} = \text{Max.}, V_{OUT} = GND$		-300		-300	mA
$I_{CC}$	$V_{CC}$ Operating Supply Current	$V_{CC} = \text{Max.},$ $I_{OUT} = 0 \text{ mA},$ $f = f_{MAX} = 1/t_{RC}$		70		60	mA
$I_{SB1}$	Automatic $\overline{CE}$ Power-Down Current—TTL Inputs	Max. $V_{CC}$ , $\overline{CE} \geq V_{IH}$ , $V_{IN} \geq V_{IH}$ or $V_{IN} \leq V_{IL}$ , $f = f_{MAX}$		20		20	mA
$I_{SB2}$	Automatic $\overline{CE}$ Power-Down Current—CMOS Inputs	Max. $V_{CC}$ , $\overline{CE} \geq V_{CC} - 0.3\text{V}$ , $V_{IN} \geq V_{CC} - 0.3\text{V}$ or $V_{IN} \leq 0.3\text{V}, f = 0$		2		2	mA

**Capacitance<sup>[4]</sup>**

Parameter	Description	Test Conditions	Max.	Unit
$C_{IN}$ : Addresses	Input Capacitance	$T_A = 25^\circ\text{C}, f = 1 \text{ MHz},$ $V_{CC} = 5.0\text{V}$	7	pF
$C_{IN}$ : Controls			10	pF
$C_{OUT}$	Output Capacitance		10	pF

**Note:**

4. Tested initially and after any design or process changes that may affect these parameters.

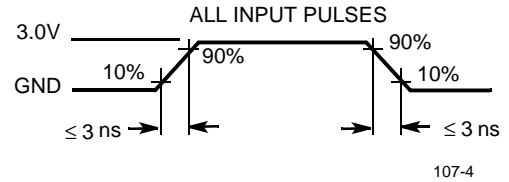
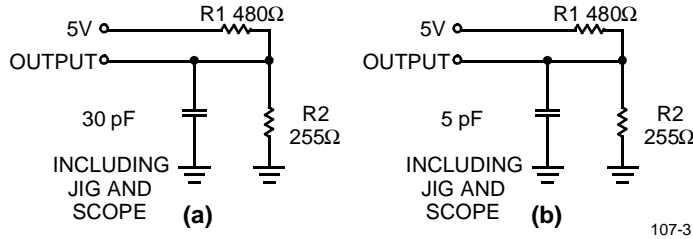
**AC Test Loads and Waveforms**

Equivalent to: THÉVENIN EQUIVALENT

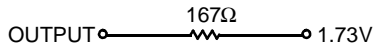
**Switching Characteristics<sup>[5]</sup> Over the Operating Range**

Parameter	Description	7C107B-12 7C1007B-12		7C107B-15 7C1007B-15		7C107B-20 7C1007B-20		7C107B-25 7C1007B-25		7C107B-35 7C1007B-35		Unit
		Min.	Max.	Min.	Max.	Min.	Max.	Min.	Max.	Min.	Max.	
<b>READ CYCLE</b>												
$t_{RC}$	Read Cycle Time	12		15		20		25		35		ns
$t_{AA}$	Address to Data Valid		12		15		20		25		35	ns
$t_{OHA}$	Data Hold from Address Change	3		3		3		3		3		ns
$t_{ACE}$	$\overline{CE}$ LOW to Data Valid		12		15		20		25		35	ns
$t_{LZCE}$	$\overline{CE}$ LOW to Low Z <sup>[6]</sup>	3		3		3		3		3		ns
$t_{HZCE}$	$\overline{CE}$ HIGH to High Z <sup>[6, 7]</sup>		6		7		8		10		10	ns
$t_{PU}$	$\overline{CE}$ LOW to Power-Up	0		0		0		0		0		ns
$t_{PD}$	$\overline{CE}$ HIGH to Power-Down		12		15		20		25		35	ns
<b>WRITE CYCLE<sup>[8]</sup></b>												
$t_{WC}$	Write Cycle Time	12		15		20		25		35		ns
$t_{SCE}$	$\overline{CE}$ LOW to Write End	10		12		15		20		25		ns
$t_{AW}$	Address Set-Up to Write End	10		12		15		20		25		ns
$t_{HA}$	Address Hold from Write End	0		0		0		0		0		ns
$t_{SA}$	Address Set-Up to Write Start	0		0		0		0		0		ns
$t_{PWE}$	$\overline{WE}$ Pulse Width	10		12		15		20		25		ns
$t_{SD}$	Data Set-Up to Write End	7		8		10		15		20		ns
$t_{HD}$	Data Hold from Write End	0		0		0		0		0		ns
$t_{LZWE}$	$\overline{WE}$ HIGH to Low Z <sup>[6]</sup>	3		3		3		3		3		ns
$t_{HZWE}$	$\overline{WE}$ LOW to High Z <sup>[6, 7]</sup>		6		7		8		10		10	ns

**Notes:**

- Test conditions assume signal transition time of 3 ns or less, timing reference levels of 1.5V, input pulse levels of 0 to 3.0V, and output loading of the specified  $I_{OL}/I_{OH}$  and 30-pF load capacitance.
- At any given temperature and voltage condition,  $t_{HZCE}$  is less than  $t_{LZCE}$  and  $t_{HZWE}$  is less than  $t_{LZWE}$  for any given device.
- $t_{HZCE}$  and  $t_{HZWE}$  are specified with a load capacitance of 5 pF as in part (b) of AC Test Loads. Transition is measured  $\pm 500$  mV from steady-state voltage.
- The internal write time of the memory is defined by the overlap of  $\overline{CE}$  LOW and  $\overline{WE}$  LOW.  $\overline{CE}$  and  $\overline{WE}$  must be LOW to initiate a write, and the transition of any of these signals can terminate the write. The input data set-up and hold timing should be referenced to the leading edge of the signal that terminates the write.

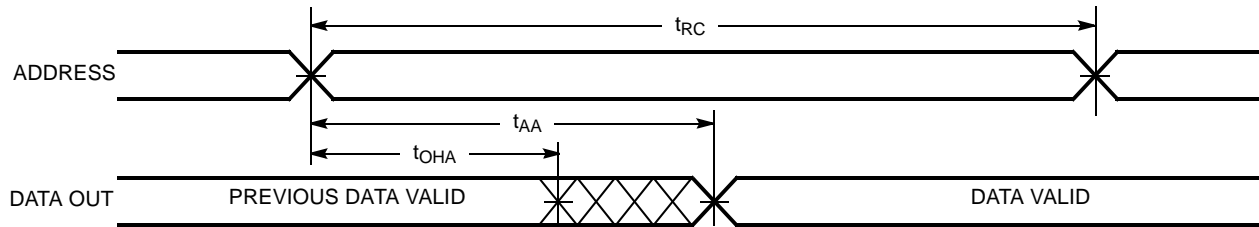
**Switching Waveforms**
**Read Cycle No. 1** <sup>[10, 11]</sup>

107-6

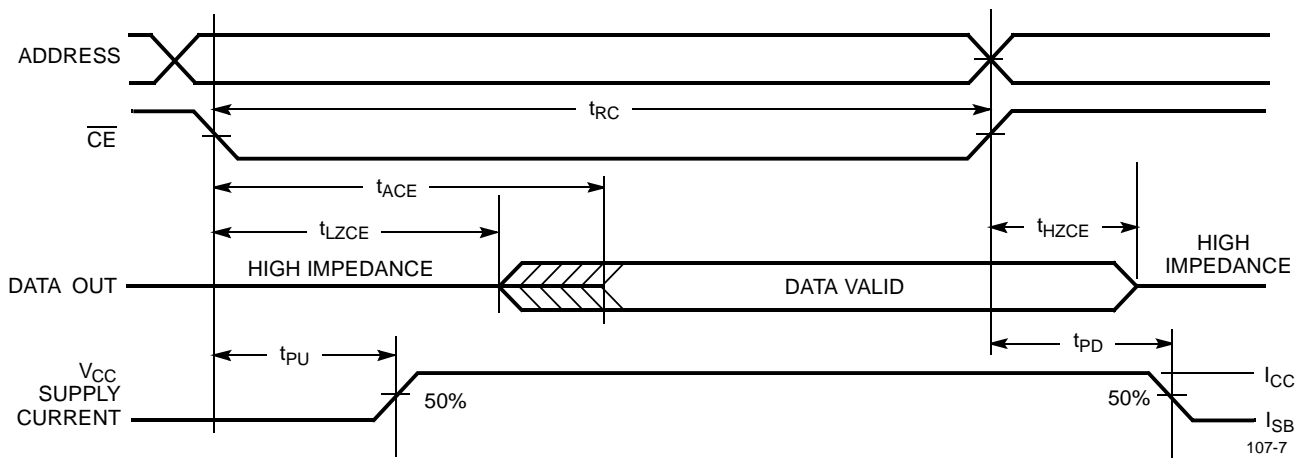
**Read Cycle No. 2** <sup>[11, 12]</sup>

107-7

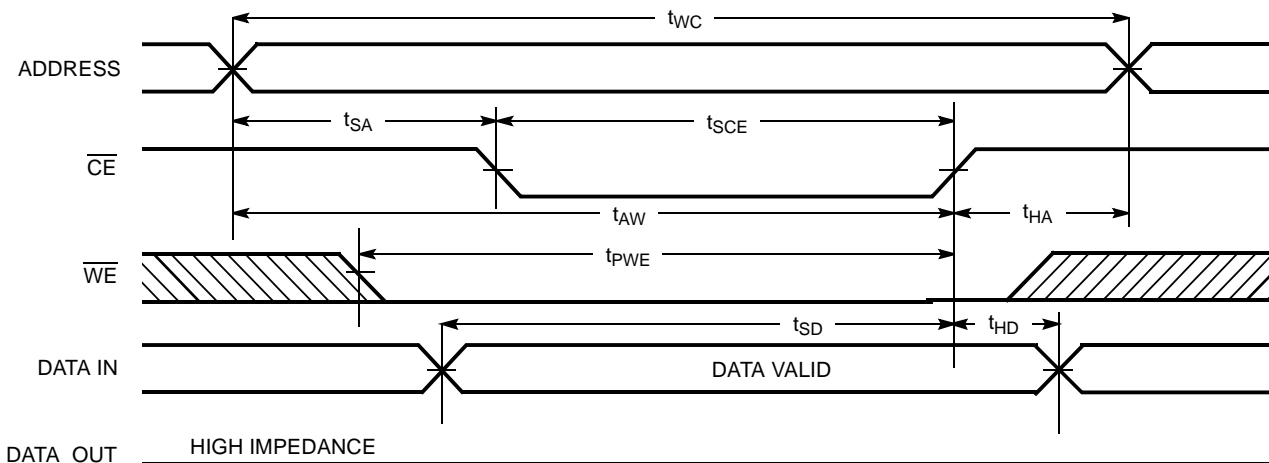
**Write Cycle No. 1 (CE Controlled)** <sup>[13]</sup>

107-8

**Notes:**

9. No input may exceed  $V_{CC} + 0.5V$ .
10. Device is continuously selected,  $\overline{CE} = V_{IL}$ .
11.  $\overline{WE}$  is HIGH for read cycle.
12. Address valid prior to or coincident with  $\overline{CE}$  transition LOW.

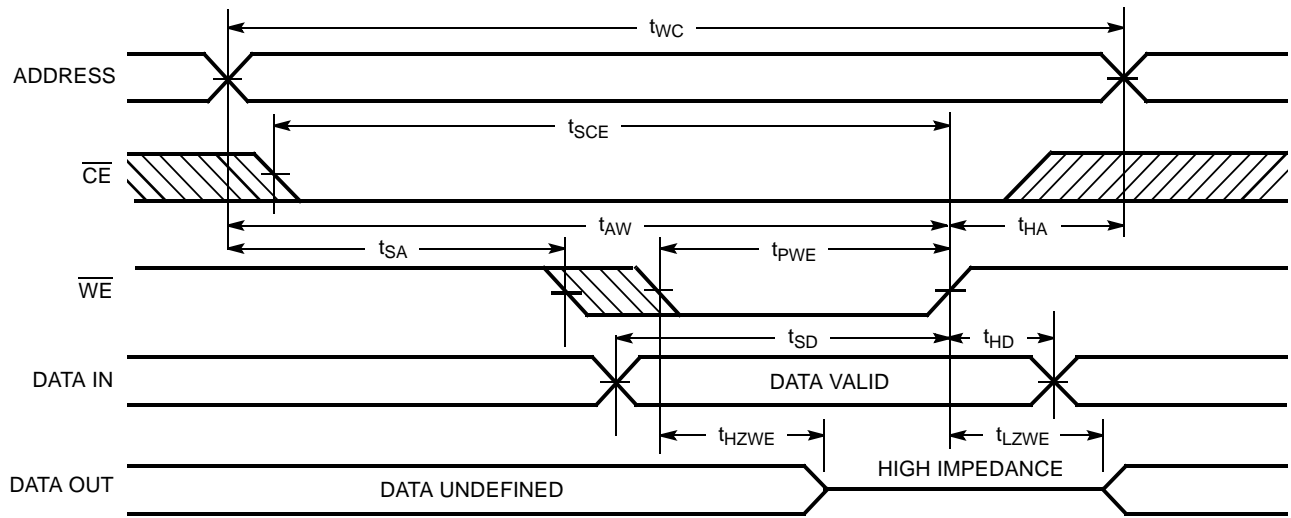
**Switching Waveforms (continued)**
**Write Cycle No. 2 (WE Controlled)<sup>[13]</sup>**

107-9

**Note:**

 13. If  $\overline{CE}$  goes HIGH simultaneously with  $\overline{WE}$  going HIGH, the output remains in a high-impedance state.

**Truth Table**

$\overline{CE}$	$\overline{WE}$	$D_{OUT}$	Mode	Power
H	X	High Z	Power-Down	Standby ( $I_{SB}$ )
L	H	Data Out	Read	Active ( $I_{CC}$ )
L	L	High Z	Write	Active ( $I_{CC}$ )

**Ordering Information**

Speed (ns)	Ordering Code	Package Name	Package Type	Operating Range
12	CY7C107B-12VC	V28	28-Lead (400-Mil) Molded SOJ	Commercial
	CY7C1007B-12VC	V28	28-Lead (300-Mil) Molded SOJ	Commercial
15	CY7C107B-15VC	V28	28-Lead (400-Mil) Molded SOJ	Commercial
	CY7C1007B-15VC	V28	28-Lead (300-Mil) Molded SOJ	Commercial
15	CY7C107B-15VI	V28	28-Lead (400-Mil) Molded SOJ	Industrial
	CY7C1007B-15VI	V28	28-Lead (300-Mil) Molded SOJ	Industrial
20	CY7C107B-20VC	V28	28-Lead (400-Mil) Molded SOJ	Commercial
	CY7C1007B-20VC	V28	28-Lead (300-Mil) Molded SOJ	Commercial
25	CY7C107B-25VC	V28	28-Lead (400-Mil) Molded SOJ	Commercial
	CY7C1007B-25VC	V28	28-Lead (300-Mil) Molded SOJ	Commercial

Contact factory for "L" version availability.

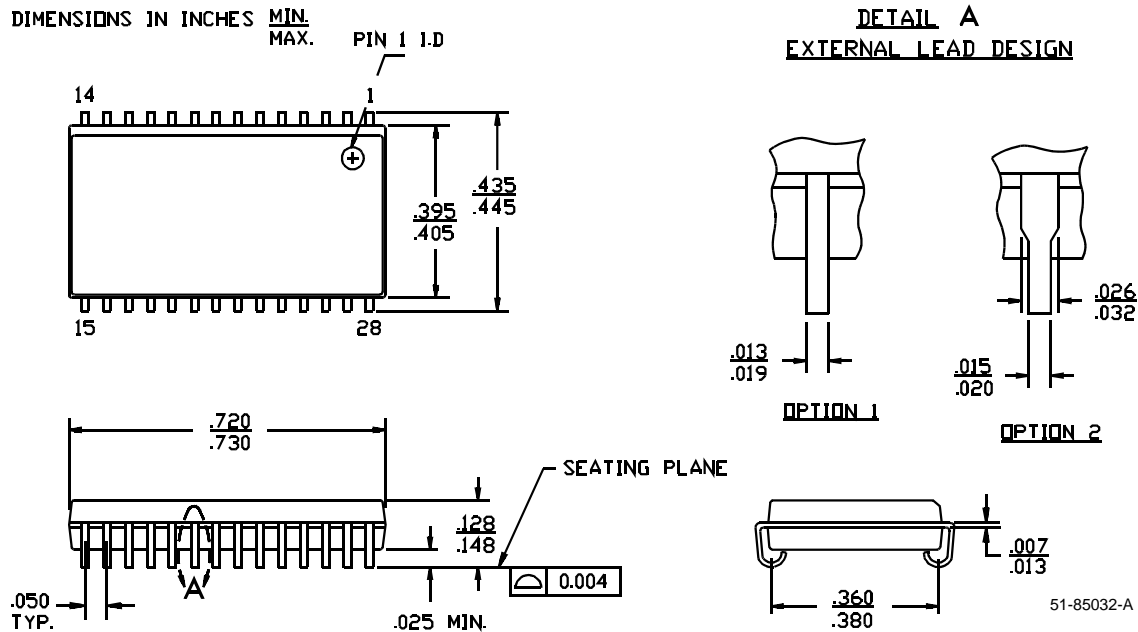
**Package Diagrams**
**28-Lead (400-Mil) Molded SOJ V28**

28-Lead (300-Mil) Molded SOJ V21

DIMENSIONS IN INCHES MIN.  
MAX.

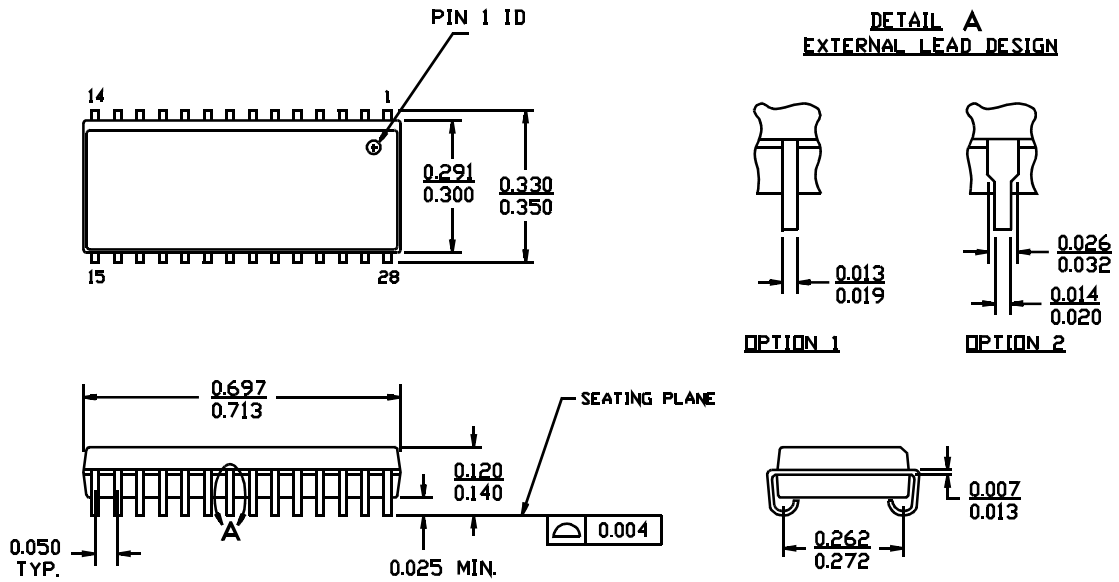





<b>Document Title: CY7C107B/CY7C1007B 1M x 1 Static RAM</b> <b>Document Number: 38-05030</b>				
<b>REV.</b>	<b>ECN NO.</b>	<b>Issue Date</b>	<b>Orig. of Change</b>	<b>Description of Change</b>
**	109950	12/02/01	SZV	Change from Spec number: 38-01116 to 38-05030