



# CMD11504 Series Right Angle Surface Mount LED



CMD11504 Series Bright Angle™ Right Angle Surface Mount LED in 3 colors or 1 bicolor

## Key Features

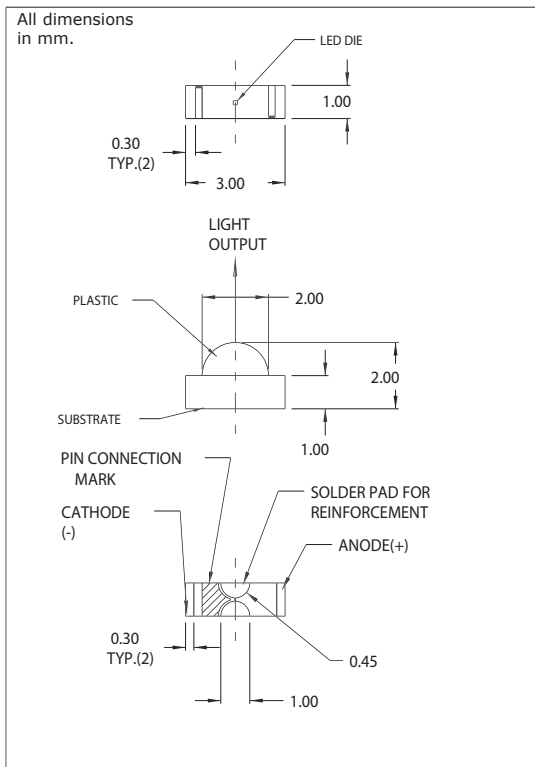

- Right angle mounting.
- Compact size: 3.00mm x 1.00mm x 2.00mm
- High brightness

### Surface Mount Technology

- Tape and reel packaged for high-speed autoinsertion.
- Convection and vapor-phase reflow compatible.
- Compact form enables high density placement.
- Packaged 3000 pieces per reel.
- REACH and RoHS Compliant

### Leading Edge LED Optoelectronic Performance

- Consistent high brightness.

### Exceptional Reliability

- Stringent process controls assure quality.
- Extensive qualification testing to meet strictest requirements.
- Designed to permit easy post-reflow solder joint inspection.

## Electro-Optical Characteristics and Ratings

| Part Number | Color     | Lens Color  | Luminous Intensity @ 20mA |            | Forward Voltage |          | Viewing Angle (deg.) | Peak Wavelength (nm) |
|-------------|-----------|-------------|---------------------------|------------|-----------------|----------|----------------------|----------------------|
|             |           |             | Min. (mcd)                | Typ. (mcd) | Typ. (V)        | Max. (V) |                      |                      |
| CMD11504UR  | Red       | Water Clear | 6.2                       | 12.4       | 1.7             | 2.3      | 130                  | 660                  |
| CMD11504G   | Green     | Water Clear | 2.6                       | 5.2        | 2.1             | 2.8      | 130                  | 560                  |
| CMD11504Y   | Yellow    | Water Clear | 1.5                       | 3.0        | 2.1             | 2.8      | 136                  | 580                  |
| CMD11504R/G | Red/Green | Water Clear | 6.2/12.4                  | 8.8/17.6   | 1.7/2.1         | 2.3/2.8  | 148/149              | 572/647              |

# Product Specifications - CMD11504UR (Red)

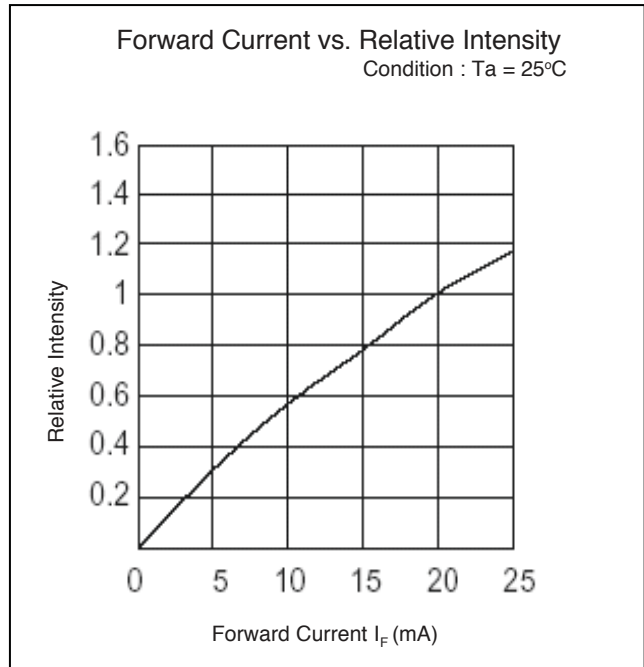
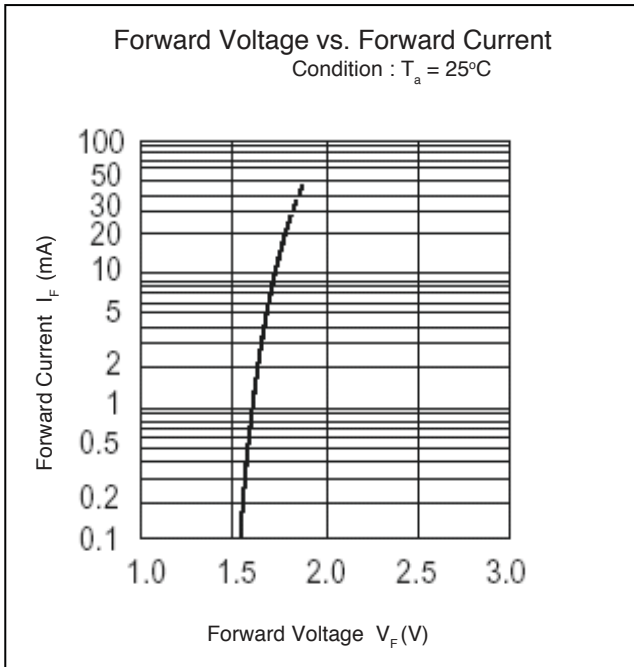
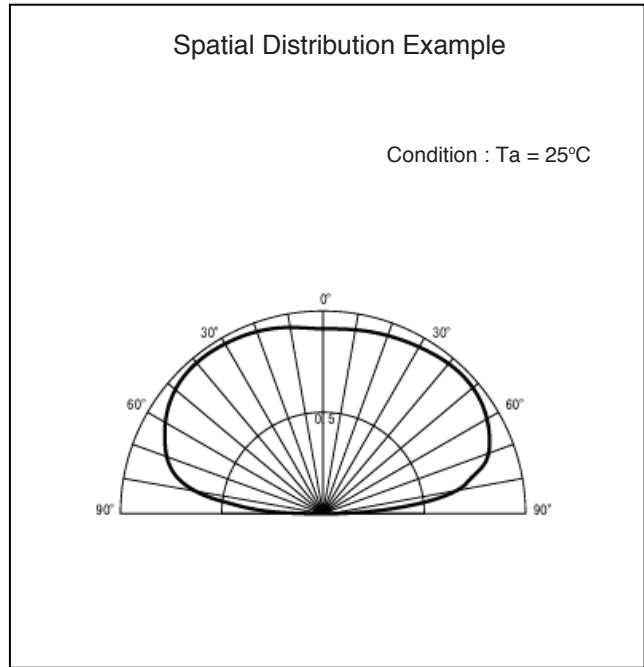
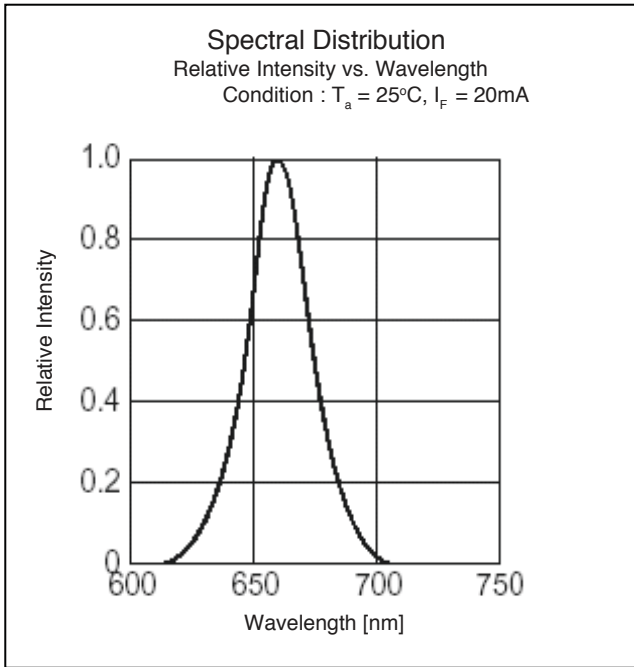

# Product Specifications - CMD11504UR (Red)

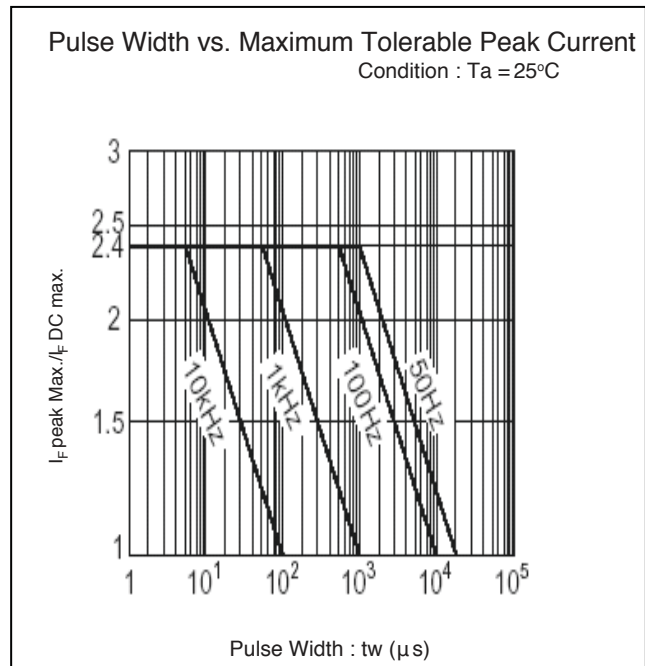
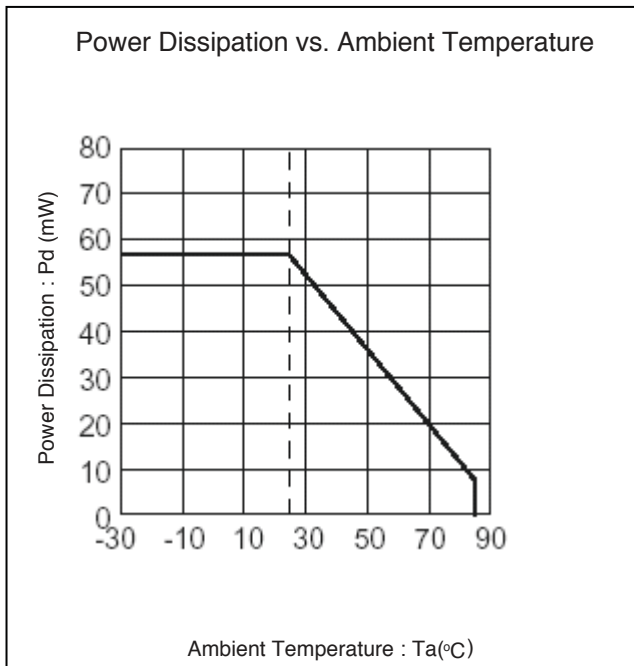
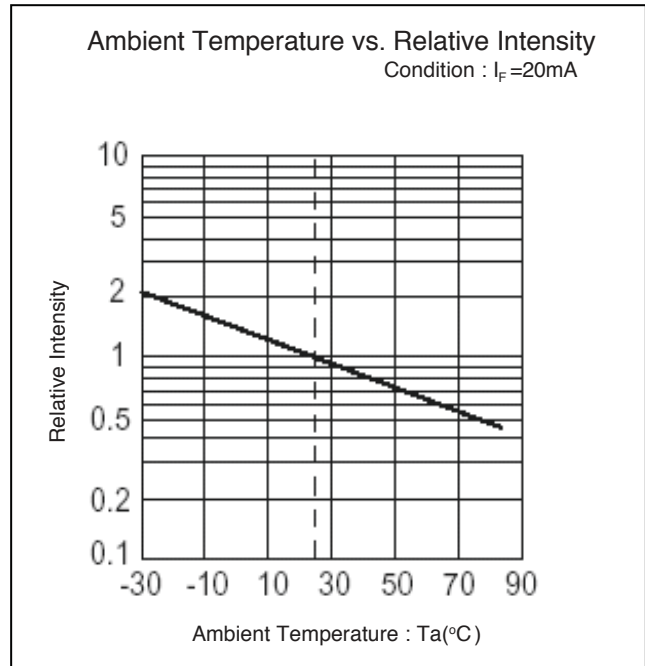
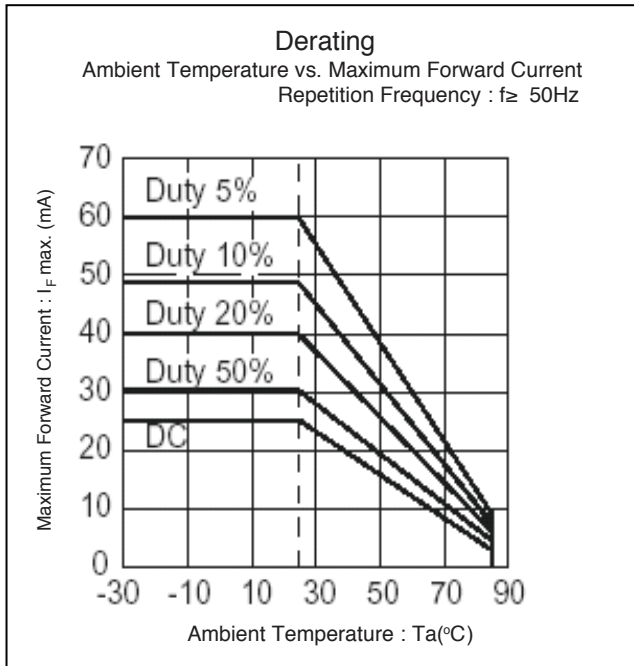

# Product Specifications - CMD11504G (Green)

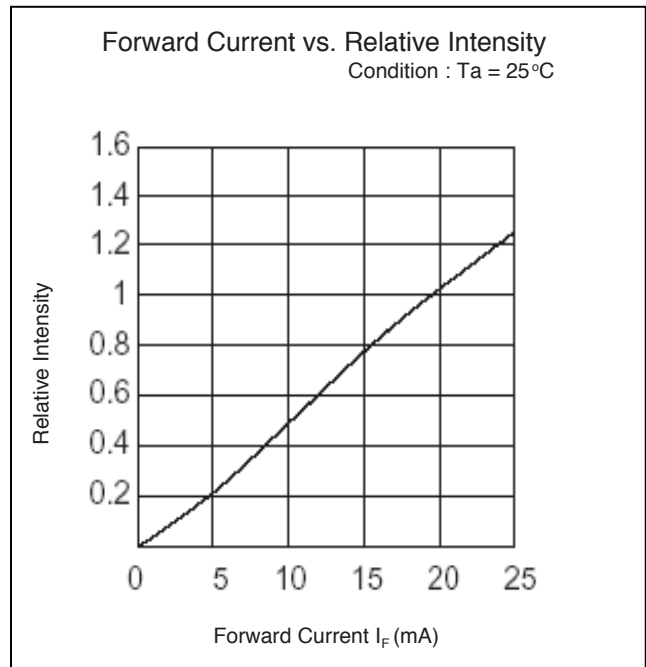
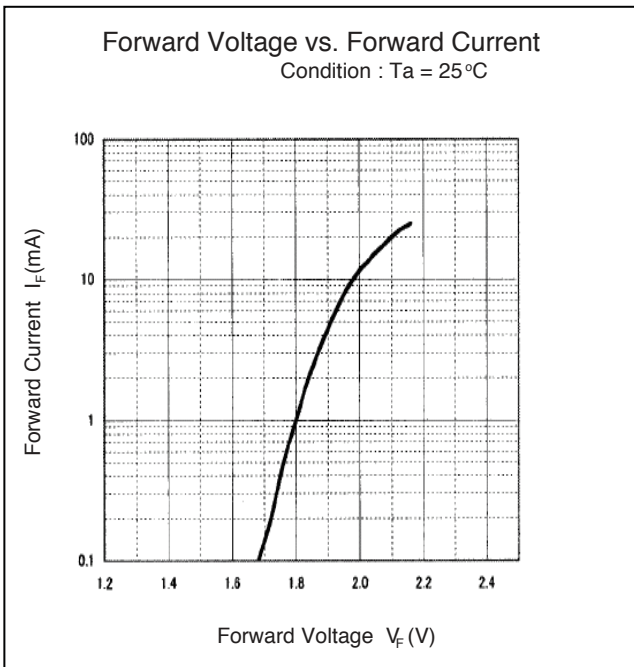
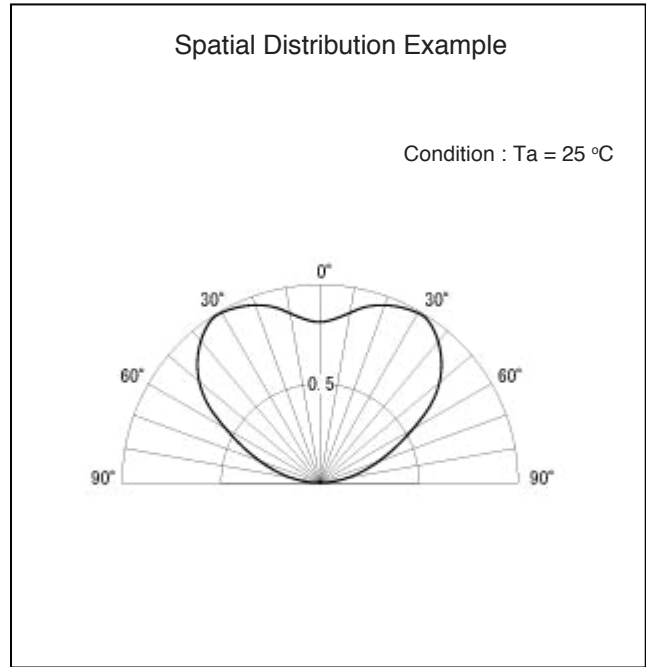
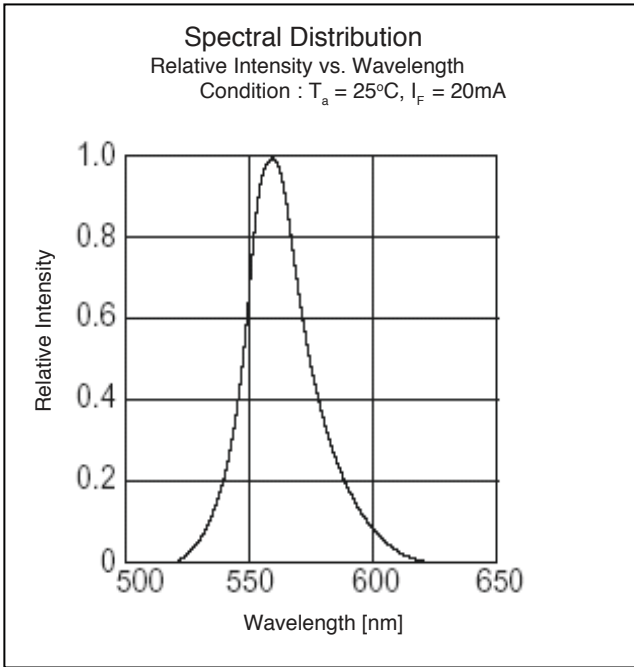

# Product Specifications - CMD11504G (Green)

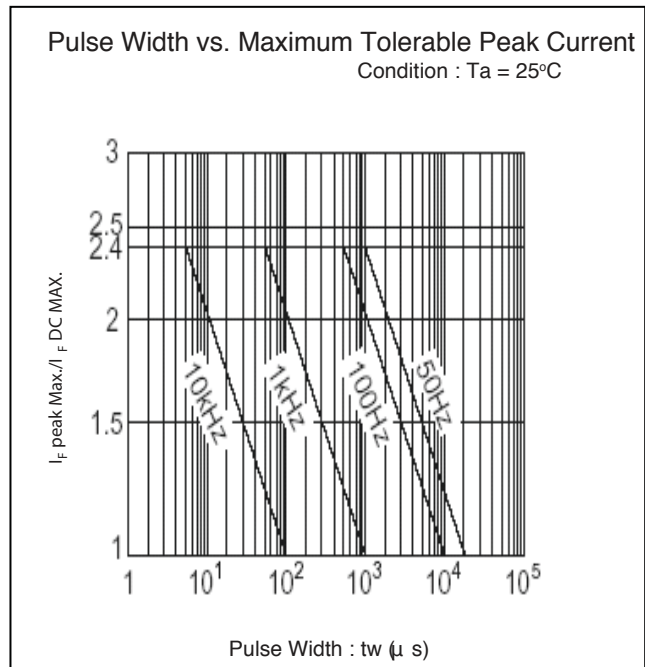
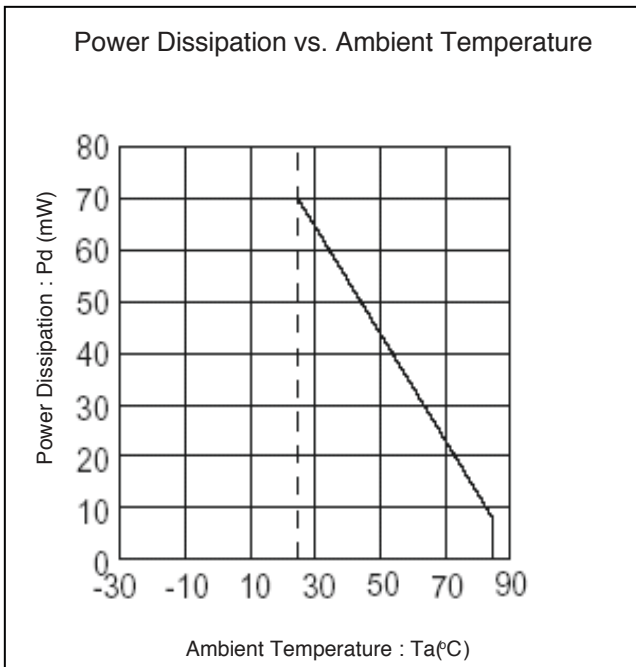
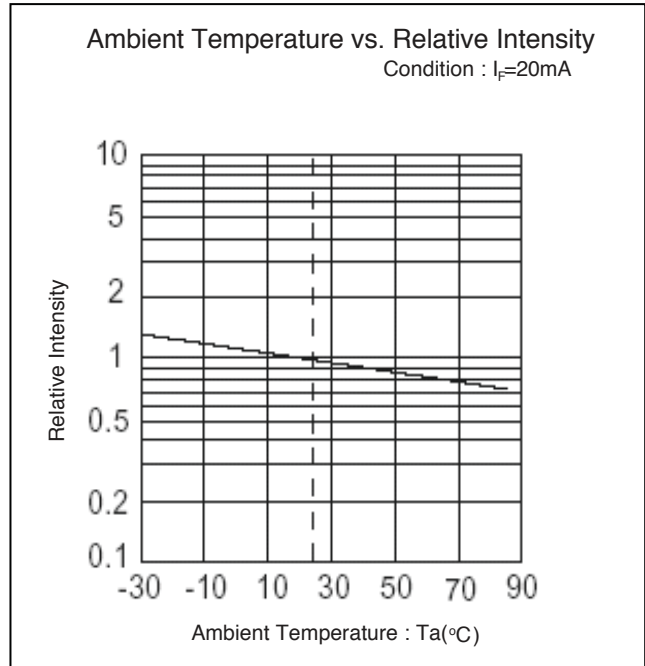
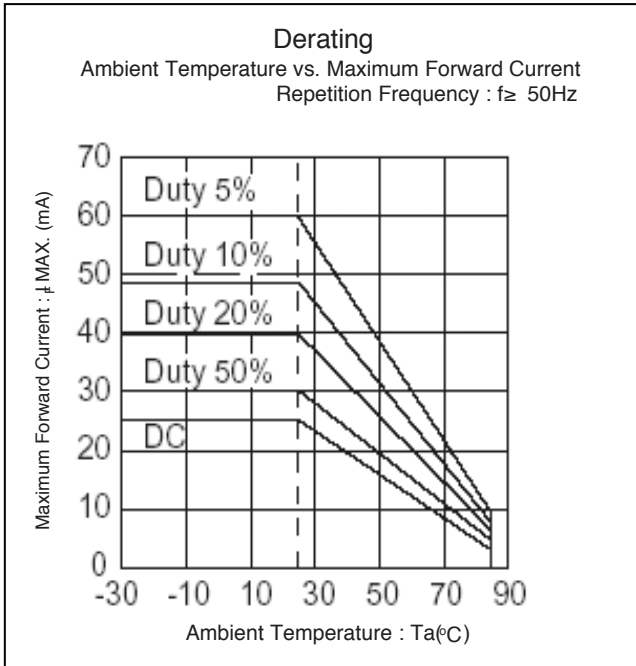

# Product Specifications - CMD11504Y (Yellow)

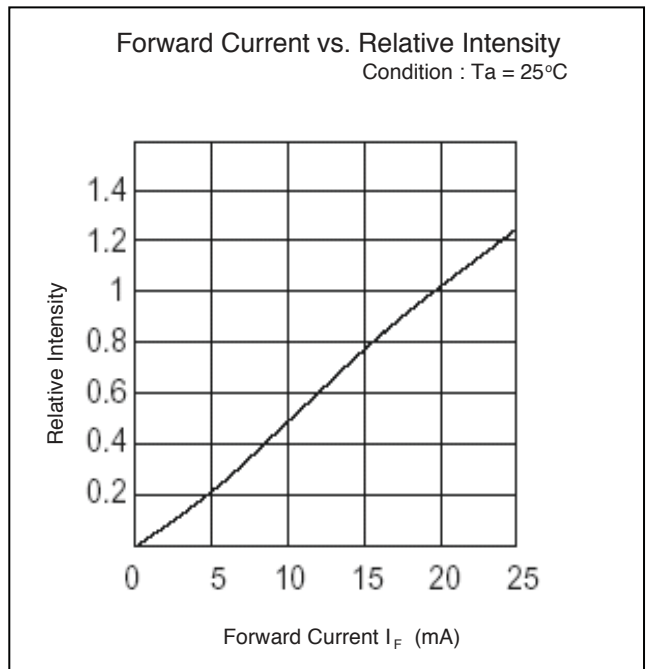
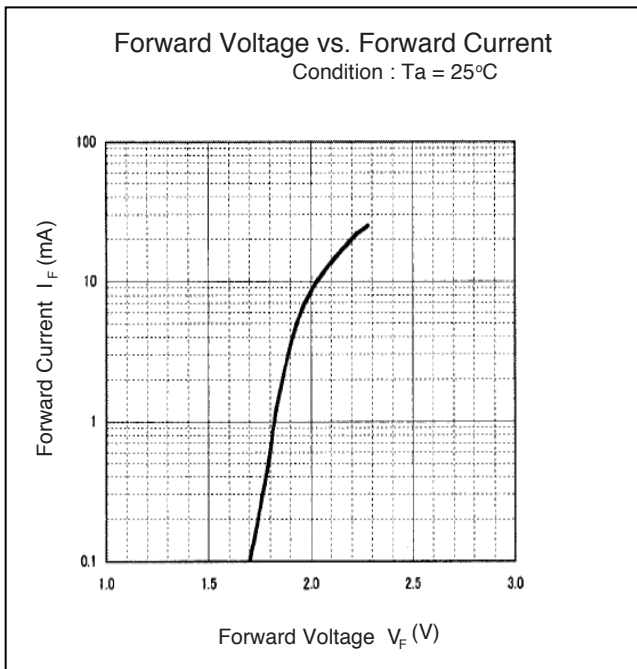
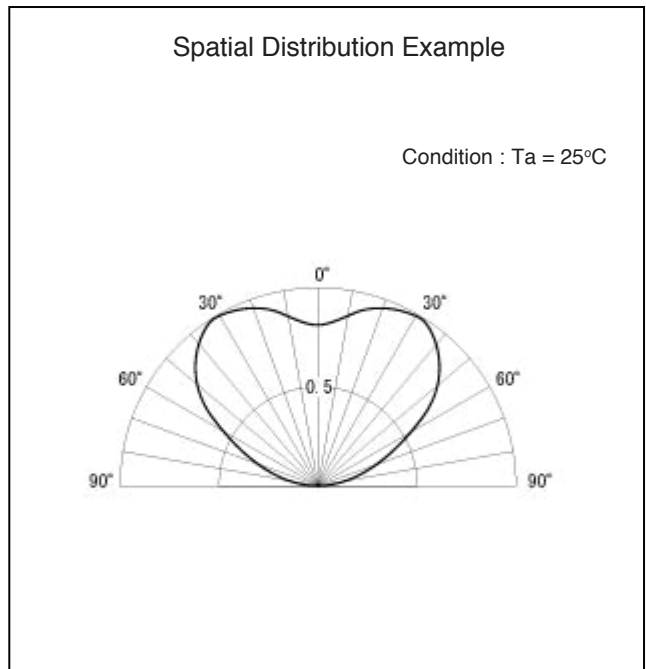
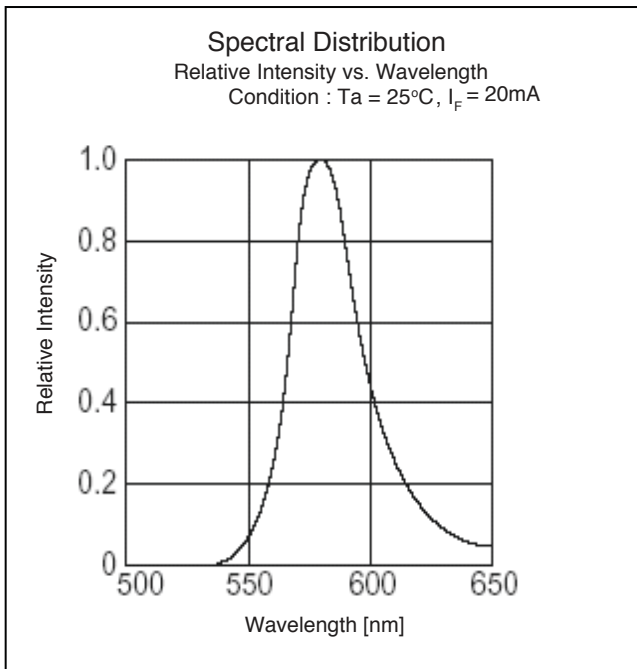

# Product Specifications - CMD11504Y (Yellow)

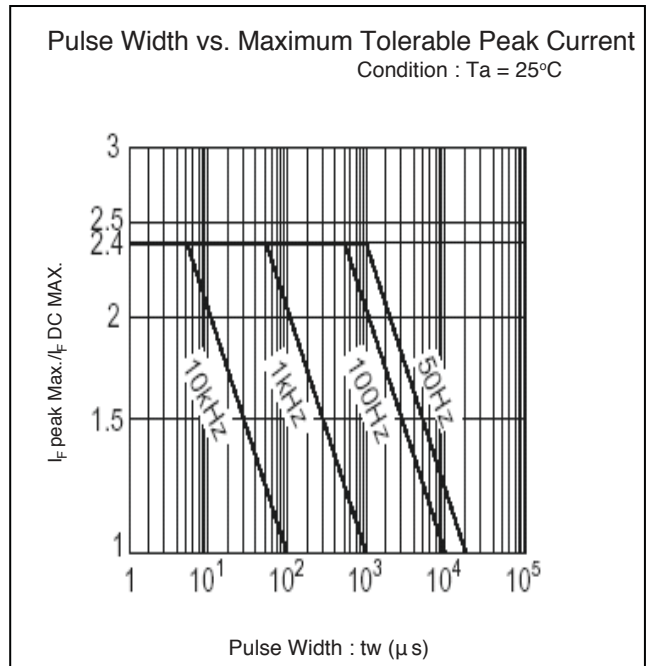
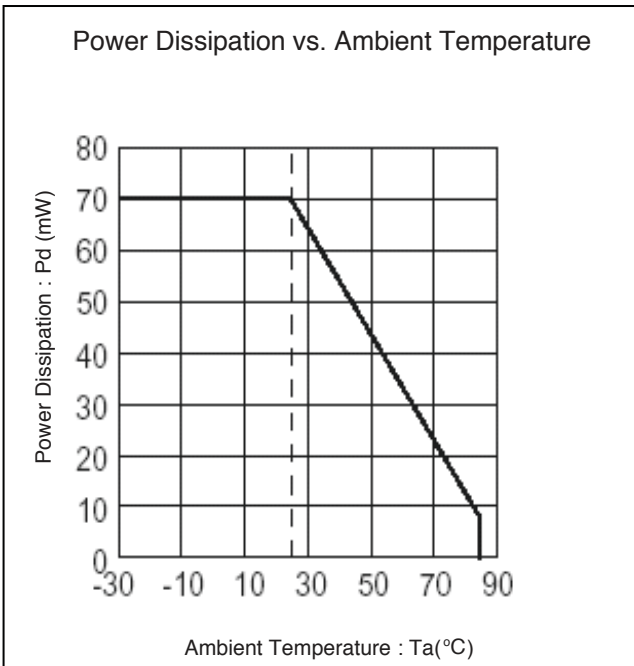
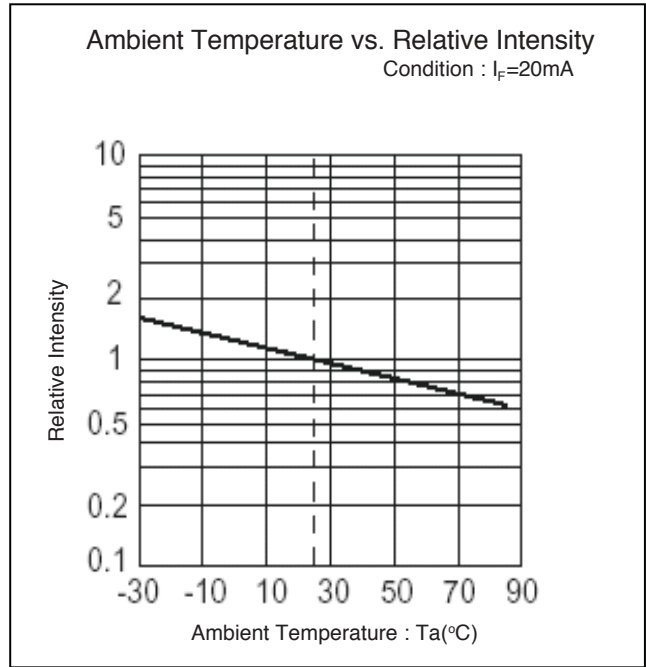
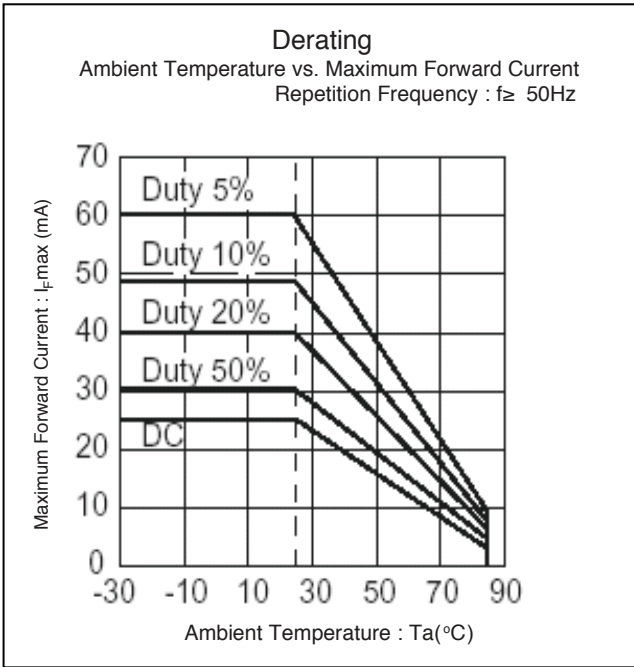

# Product Specifications - CMD11504R/G (Red/Green)

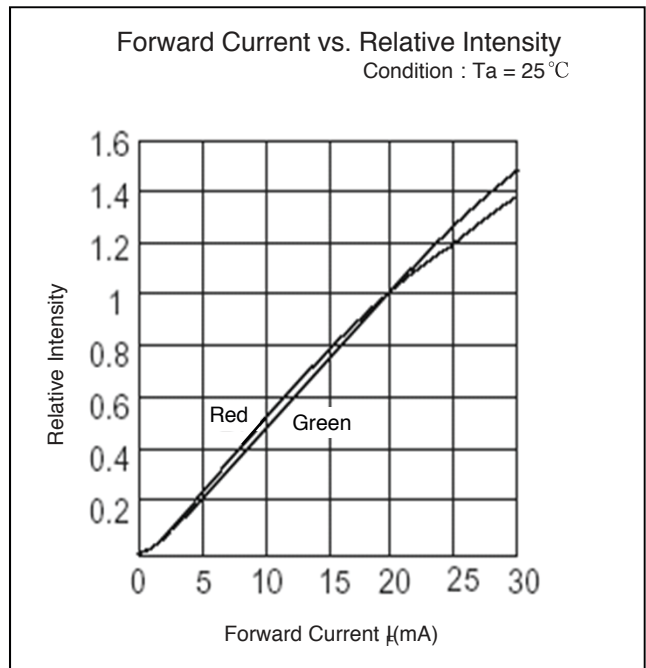
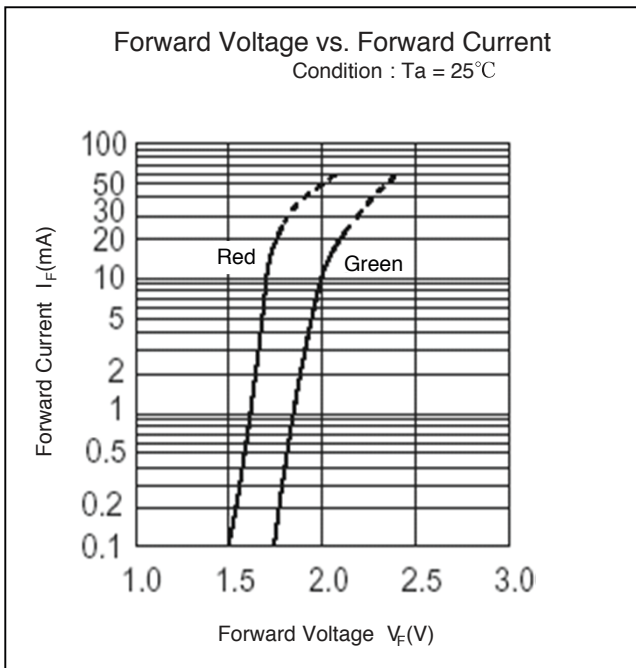
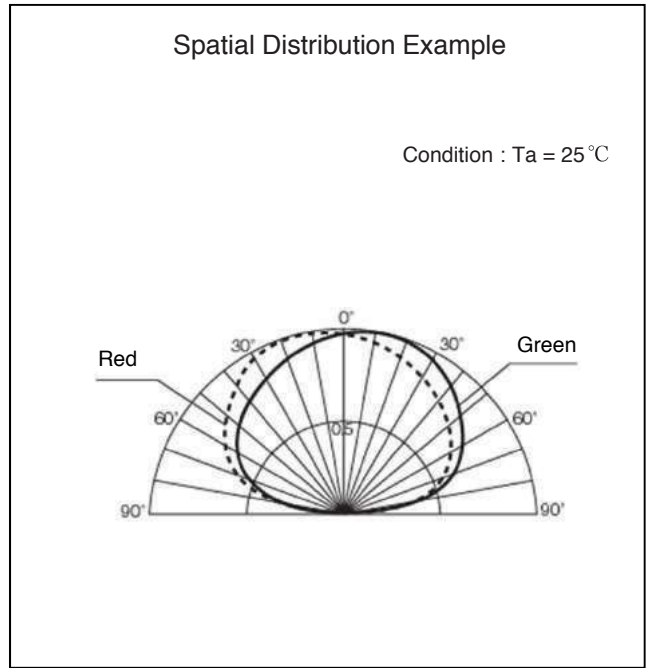
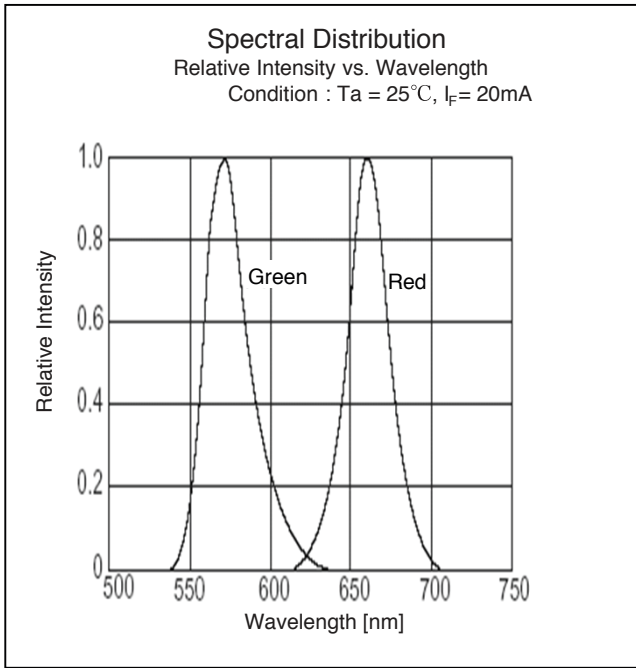



# Product Specifications - CMD11504R/G (Red/Green)

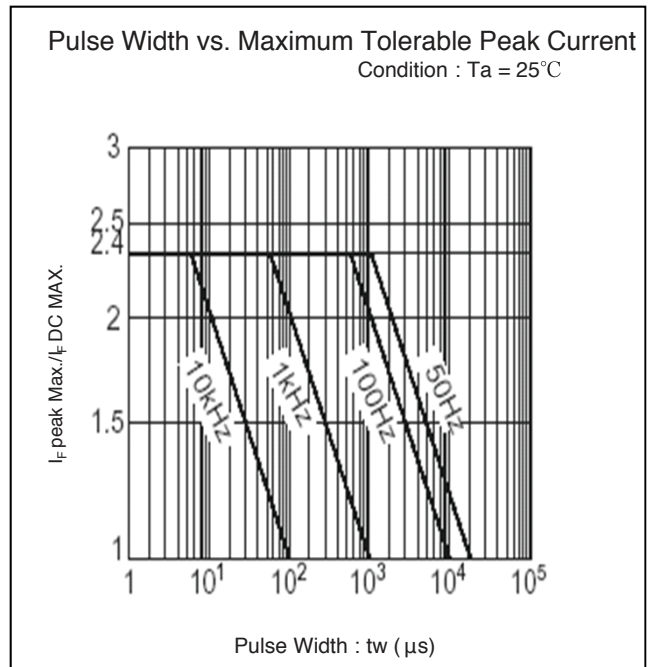
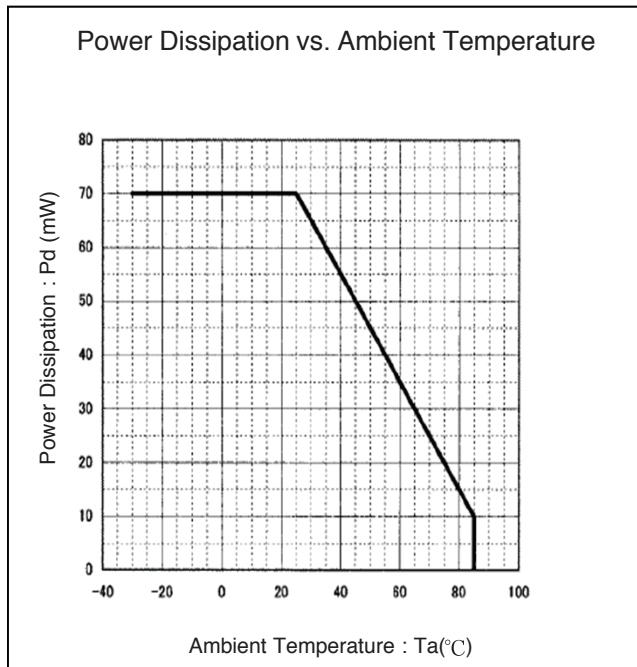
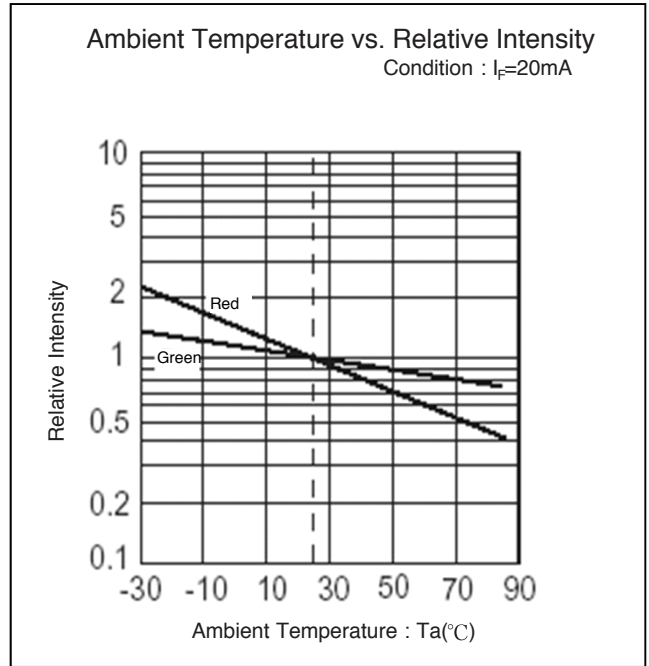
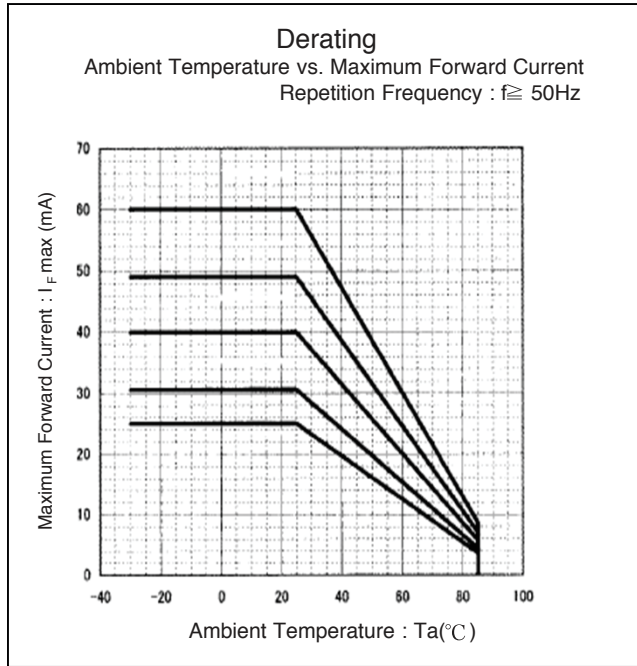

## Solder Pad Geometry

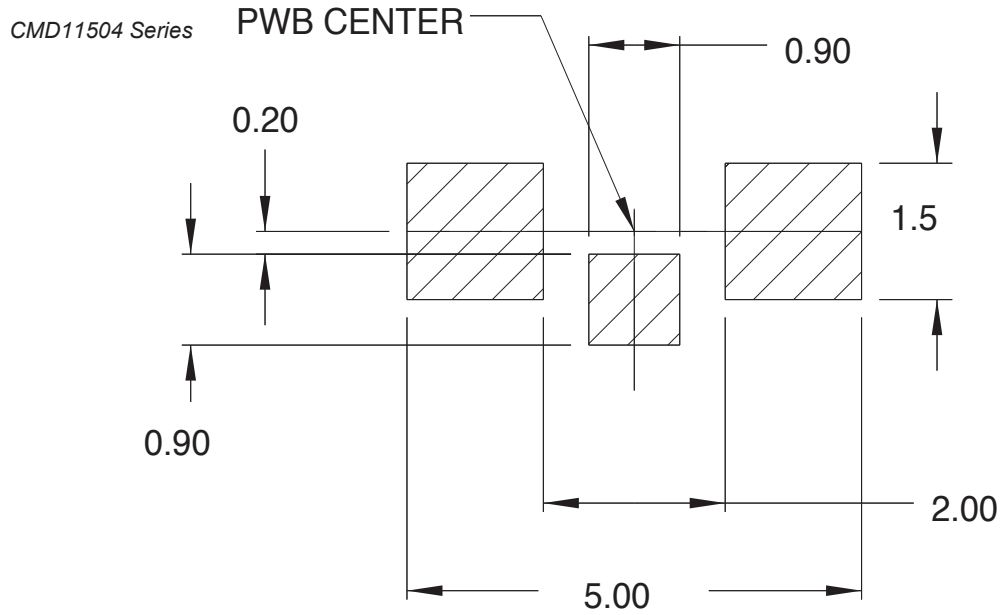

All dimensions in mm.

## Compliance and Approvals

