

UCD9081 Power Supply Sequencer and Monitor EVM

This user's guide describes the operation of the UCD9081 Power Supply Sequencer evaluation module (EVM) and graphical user interface (GUI).

Contents

1	System Overview	2
2	Hardware Overview.....	2
3	GUI Overview	7
4	EVM Design Configuration Information.....	13
5	EVM Schematic.....	15
6	Bill of Materials	16
7	Related Documentation From Texas Instruments	17

List of Figures

1	System Block Diagram	2
2	UCD9081EVM Functionality.....	3
3	UCD9081EVM Hookup	6
4	GUI Main Window	8
5	GUI Help Window.....	9
6	GUI System Configuration Window	10
7	GUI Rail Configuration Window	10
8	GUI GPO Configuration Window	12
9	GUI User Data Window	12

List of Tables

1	UCD9081 Jumpers	5
---	-----------------------	---

1 System Overview

The system block diagram is shown in [Figure 1](#).

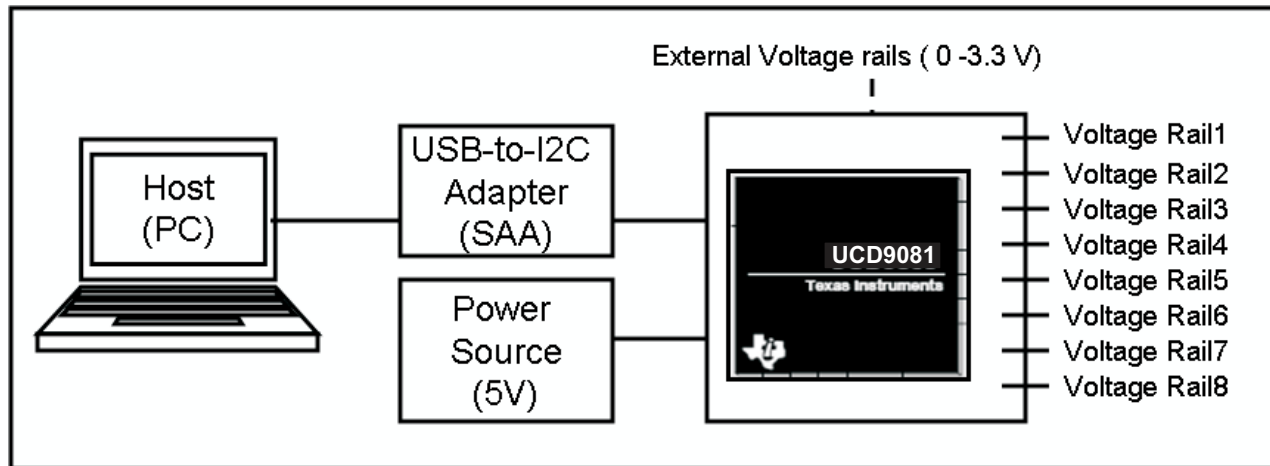

Figure 1. System Block Diagram

The system consists of these components:

- **Host (PC)**—a Windows™ personal computer (PC) – used to configure and monitor the UCD9081EVM. The GUI operates on the host. For the GUI to execute properly, the host needs to have the Windows .NET v2.0 Framework installed.
- **USB-to-I²C adapter**—UCD9081EVM uses the I²C™ interface for communication with the host. The TI-supplied USB-to-I²C adapter does the appropriate conversion so the host can use the USB interface for communication.
- **Power source**—UCD9081EVM requires a 5-V, 0.5-A power source. This power is used by the UCD9081, LEDs, and onboard rails, if used.
- **External voltage rails**—when configured properly, UCD9081EVM can sequence and monitor external voltage source as well.
- **UCD9081EVM**—EVM board that houses the UCD9081 and peripheral circuits. The EVM can sequence and monitor onboard as well as external voltage rails, as previously explained.

2 Hardware Overview

The UCD9081EVM allows evaluation of the UCD9081 Power Supply Sequencer and Monitor with Error Logging. The UCD9081 is a highly configurable, 8-channel power supply sequencer (see the [SLVS813](#) data sheet) with three additional general-purpose digital outputs.

The UCD9081EVM can be configured and monitored through a Windows GUI application running on a PC. The GUI communicates with the UCD9081EVM through the USB Interface Adapter (included with EVM kit), which acts as an I²C master for the board.

The UCD9081EVM and associated functional controls are shown in [Figure 2](#).

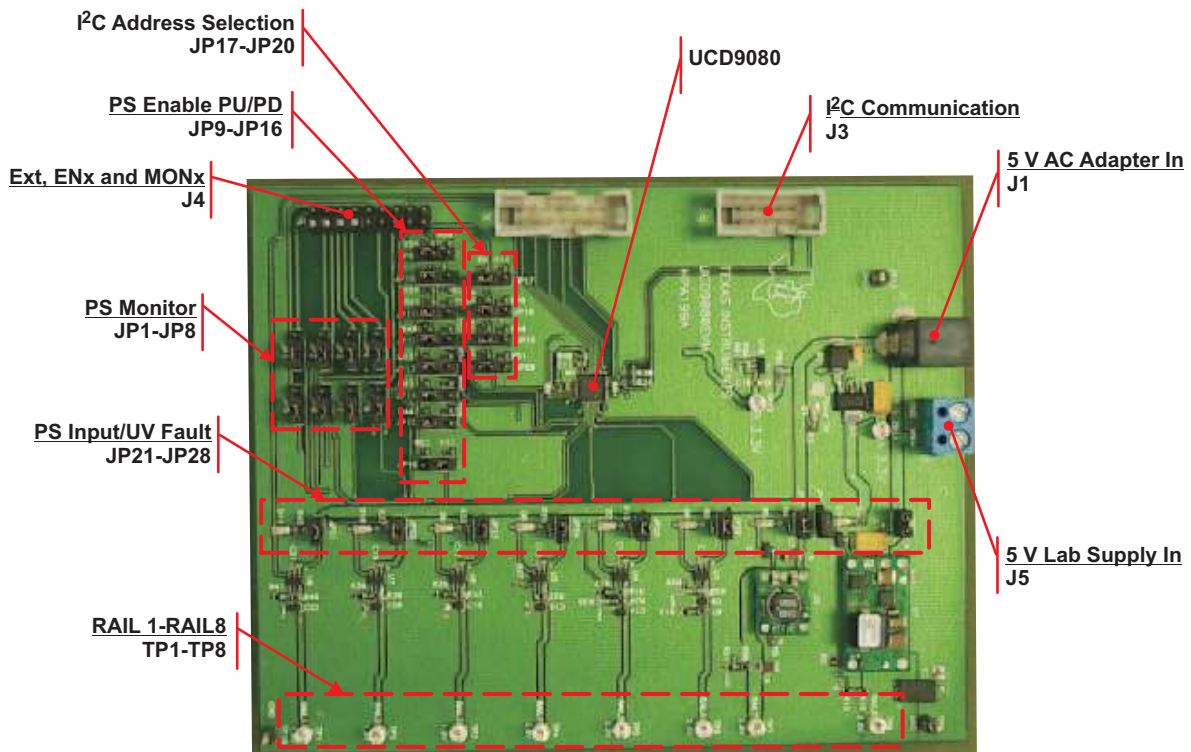

Figure 2. UCD9081EVM Functionality

The UCD9081EVM provides the following functionality:

- Sequencing for the eight onboard power supply rails
- Monitoring for the eight onboard power supply rails
- Power supply enables can be sent off board via a header to sequence external power supplies.
- External power supplies can be monitored by connecting them to an onboard header (jumpers select onboard or offboard monitoring).
- Sequencing for the general-purpose outputs
- Jumpers for configuring the I²C address of the UCD9081 (detected at start-up)
- Standard 100-kHz I²C communication via I²C connector to USB adapter for connection to a PC
- LEDs for board power and power supply enables for quick visible indication of power supply status

The eight power supplies, provided on the UCD9081EVM, are a combination of low-dropout regulators (LDO), power converter integrated circuits (IC), and power converter modules, all from Texas Instruments (TI).

Rails 1-6 have a TI TPS76901 LDO for generating voltages from 1.4 V to 2.4 V. Rail 7 has a TI PTH04070 switching power supply IC for generating a 2.6-V output. Rail 8 has a TI PTH05050 power module used for generating a 2.8-V output. This set of power supplies are provided for generating different output voltages on the board for the testing of different sequencing and monitoring conditions.

Users can communicate with the board using the I²C protocol through the supplied USB Interface Adapter and GUI. The GUI helps users to change the sequencer configuration as well as monitor voltage and device status from a Windows PC.

2.1 Connectors

The UCD9081EVM has connectors for power and I²C communications. J1 provides input power interface from an external 5-V adapter and J5 provides a laboratory power supply interface to the UCD9081EVM.

J3 provides the I²C communication interface to the UCD9081EVM. The USB Interface Adapter includes a ribbon cable that can be connected to J3. The adapter is connected to a Windows-based PC.

The J4 header provides a sequencing and monitoring interface to an external system, rather than to the eight supplies provided on the EVM. Each of the eight power supply rails supported by the UCD9081 has an enable and a monitoring pin accessible at J4. Through the use of jumpers for the monitor pins, the user can choose to monitor either the external rails or the internal EVM rails.

CAUTION

Ensure that if you are configuring the UCD9081EVM to monitor an external power supply, the voltage is appropriately scaled down to between 0 V – 2.5 V (if using the internal reference) or between 0 V – 3.3 V (if using the external reference).

2.2 Jumpers

The UCD9081EVM operation can be configured using jumpers:

- Onboard or external power supply voltage monitoring
- Onboard or external power supply enabling
- Setting of the I²C address for the system
- Creating undervoltage faults for the onboard power supplies

See [Table 1](#) for descriptions and default settings for the jumpers on the UCD9081EVM.

Table 1. UCD9081 Jumpers

Number	Function	Default Setting
JP1–JP8	Power supply monitoring through onboard power supplies or externally connected. Connect to pins 1-2 for monitoring onboard supplies and pins 2-3 for external supplies via connector J4.	Pins 1-2 (onboard supplies)
JP9–JP16	Power supply enable signal configuration (pullup or pulldown). Enable pins for each of the channels can be either pulled up to 3.3 V or down to ground to support power supplies that have either active-high or active-low enables. Connect to pins 1-2 for pulling up to 3.3 V and connect to pins 2-3 for pulling down to ground.	Pins 1-2 (pullup to 3.3 V for active-low supply enables).
JP17–JP20	I ² C address detection. Four digital signals on the UCD9081 are sampled at start-up to determine its I ² C address. These four jumpers control, if the signals are pulled up to 3.3 V or down to ground. Connect to pins 1-2 for 3.3 V and connect to pins 2-3 for ground.	Pins 2-3 (pulldown to ground for all zero).
JP21–JP28	Undervoltage fault. For each rail, you can generate an undervoltage fault by removing this jumper. Removal of these jumpers removes input from the power supplies, causing the output voltage being monitored by the UCD9081 to fall below the configured undervoltage threshold. If the UV threshold is zero, no undervoltage occurs.	Jumper on pins 1-2 for no undervoltage fault.
JP29	EN8 shared with I ² C address detection. Can be used to disconnect RAIL8 enable from the UCD9081.	Jumper on pins 1-2.

2.3 Test Points

The UCD9081EVM provides test points that can be used for evaluation. Important voltages can be monitored with a meter through the use of the test points.

2.4 Voltage Reference

The UCD9081 can operate with either the internal voltage reference or an external voltage reference selectable using the GUI. Voltage reference selection depends on the monitoring accuracy required. The UCD9081EVM provides an accurate external reference to the V_{CC} pin of the UCD9081. When operating with the internally generated 2.5-V reference, the monitoring accuracy depends on the accuracy of the internal voltage reference (see data sheet [SLVS813](#) for details).

The default behavior of the device (and the EVM) is for an external voltage reference.

2.5 EVM Operation

The UCD9081EVM operates from 5-V DC power from either a wall adapter (through J1) or from a laboratory power supply (through J5). The UCD9081EVM has light-emitting diodes (LED) for board power and voltage rail enable indication. Use [Figure 3](#) and the following steps to set up the UCD9081EVM.

1. Connect the power source to the board and enable the power source. The red D4 LED (labeled Power On) illuminates. You then observe D1 and D5–D11 illuminate, indicating that the UCD9081 is operating.
2. Next, connect the USB interface adapter to the UCD9081EVM J3 connector using the ribbon cable provided. Plug the appropriate end of the USB cable into the adapter and the other end into your PC. GUI installation and operating instructions appear in [Section 3.1](#).

Note: For some configurations of the UCD9081 device, the installation of the JP29 jumper may have an effect on the I²C address of the device. The GUI "Discover Devices" menu item can be used to re-discover the UCD9081 device I²C address.

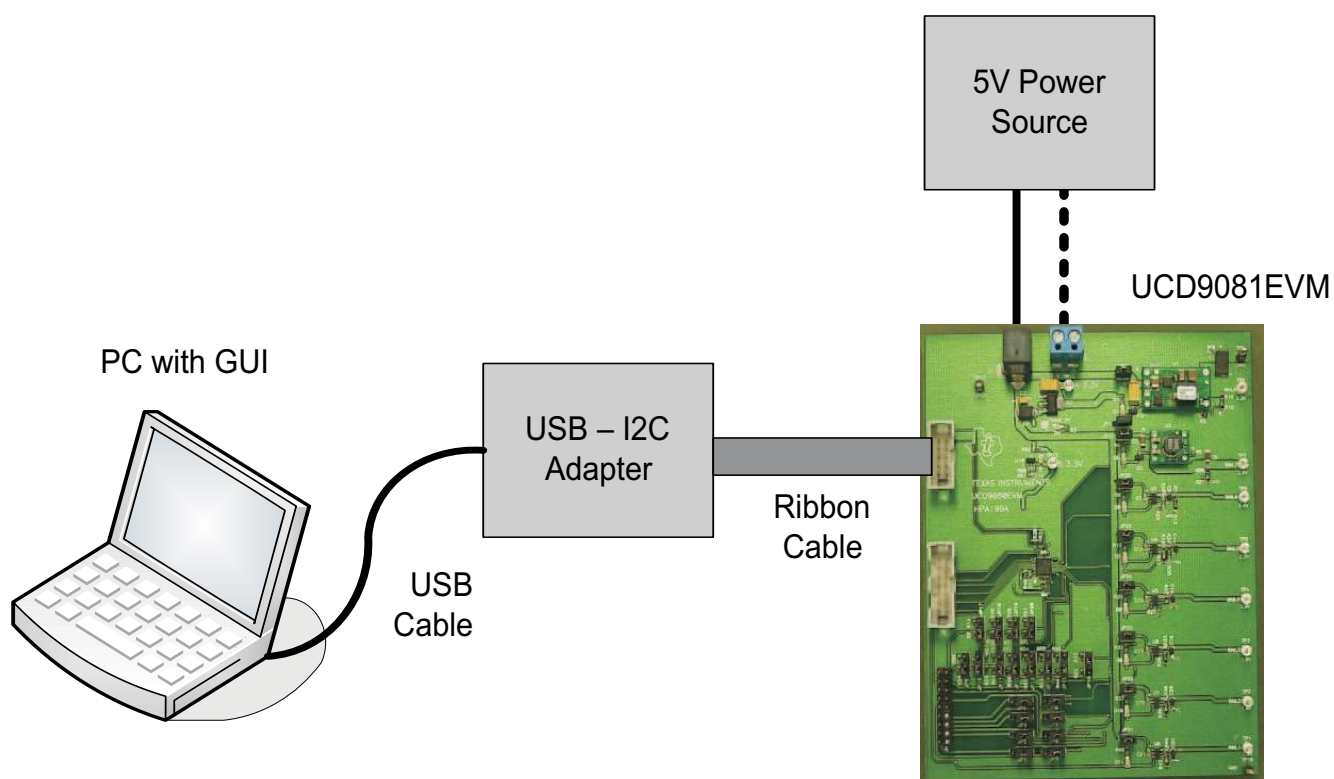

Figure 3. UCD9081EVM Hookup

3 GUI Overview

The UCD9081EVM comes with a Windows application that can be used to configure and monitor the EVM. The GUI can be used to configure all available options of the EVM such as sequencing and shutdown order, over/undervoltage timing, etc. It also can be used to monitor the operation of the sequencer by reporting current readings of voltage and error conditions on all the rails.

3.1 GUI installation

Before running the GUI application, ensure that the target hardware is connected as described in [Section 2.5](#).

Note: The UCD9081EVM application GUI is written using Microsoft .NET version 2 software and therefore requires the .NET Framework installed on the PC to run the application. No other drivers or libraries are required to run the application.

1. To determine the .NET Framework software version, you must use the Windows *Control Panel* and select *Add/Remove Programs*. The Control Panel lists all the installed PC software, and you can determine if the proper Microsoft .NET Framework version is installed.

Note: To update your .NET Framework to version 2.0, go this URL:

<http://www.microsoft.com/downloads/details.aspx?FamilyID=0856EACB-4362-4B0D-8EDD-AAB15C5E04F5&displaylang=en>

2. To install the GUI, unzip the zip file that containing the GUI binary onto your PC. You must have at least version 2.0 of the Microsoft .NET Framework installed on your PC in order to run the GUI.
3. Once you have installed the .NET Framework and the UCD9081EVM GUI, you can launch the application.

3.2 UCD9081 GUI Main Window

The GUI main window helps you monitor the EVM sequencer status and configure the EVM sequencer through the **File** and **View** menus.

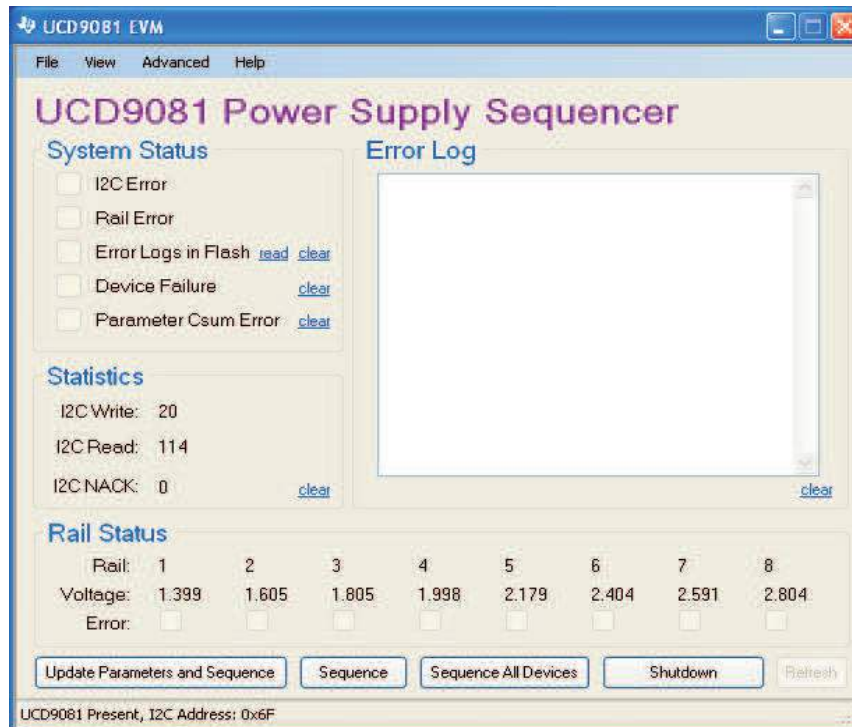

Figure 4. GUI Main Window

The UCD9081 EVM main window GUI has these areas:

- **System Status**—Red box fill indicates an error. Clear control erases the error.
 - I2C Error
 - Rail Error
 - Error Logs in Flash
 - Device Failure
 - Parameter Csum Error
- **Error Log**—contains error messages that inform the user about the operation of the sequencer.
- **Statistics**—I2C communication statistics.
 - I2C Write
 - I2C Read
 - I2C NACK
- **Rail Status**—information including monitored voltage (scaled to user-entered divider ratios) and rail error status.
- **Update Parameters and Sequence button**—Updates buffer-stored GUI information to device user flash memory and initiates a device sequence. This process takes a couple seconds, and then the sequencer is able to be monitored again.
- **Sequence button**—causes the system to sequence.
- **Sequence All Devices button**—causes all system devices to sequence.
- **Shutdown button**—initiates a system shutdown.
- **Refresh button**—causes the GUI window to refresh.
- **Menu bar**—allows selection of File, View, Advanced, and Help menu items

The **File** menu includes these commands:

- **Load Configuration**—loads a previously saved parameter (*.par) file.
- **Save Configuration**—saves the current GUI configuration to either a user parameter file (par extension) or an Intel Hex format file (hex extension).
- **Default Configuration**— loads the factory UCD9081 configuration values (NULL configuration).
- **EVM Configuration**— loads EVM-friendly UCD9081 configuration values.
- **Save I²C Transactions**—generates an ASCII text file containing configuration-specific I²C transactions (to be used by a master host to configure the UCD9081).
- **Auto-Refresh**—refresh the window contents periodically, if selected. If you want to refresh the window contents manually, click the Refresh button (not available when auto-refresh is enabled).
- **Discover Devices**—discover the slave (EVM as jumper-configured) I²C address (displayed at the bottom of the form).
- **Select Device**— allows the GUI to select which device is used if more than one device is on the bus.
- **Exit**—stop the GUI application

The **View** menu includes these commands:

- **System Configuration**—provides system voltage reference and shutdown delay field entries.
- **Rail Configuration**—provides rail configuration field entries. All Rails simultaneously opens all rail forms for comparison setup.
- **GPO Configuration**—provides GPO configuration field entries. All general-purpose outputs (GPO) simultaneously open all GPO windows for setup comparisons.
- **User Data**—provides specific user data to be uploaded to the device, such as customer-specific identification.

The **Advanced** menu includes these commands:

- **Allow Self Dependencies**— lets the user choose a rail to be dependent on itself
- **Sequence after Update**— allows an automatic sequence of the UCD9081 after the parameters are updated, or this sequence can be done manually if need be.

The **Help** menu allows the user to view the GUI revision, device type, and device version as shown in [Figure 5](#).



Figure 5. GUI Help Window

The GUI-detected **I²C address** is displayed at the bottom of the GUI Main Window. Users can change the detected I²C address on the EVM by modifying the state of jumpers JP17–JP20. If the jumpers are changed during GUI operation and the device is sequenced, the user must perform a Discover Devices command as previously outlined.

3.3 GUI System Configuration Window

The System Configuration window on the GUI is shown in Figure 6 and allows the following to be configured in the UCD9081:

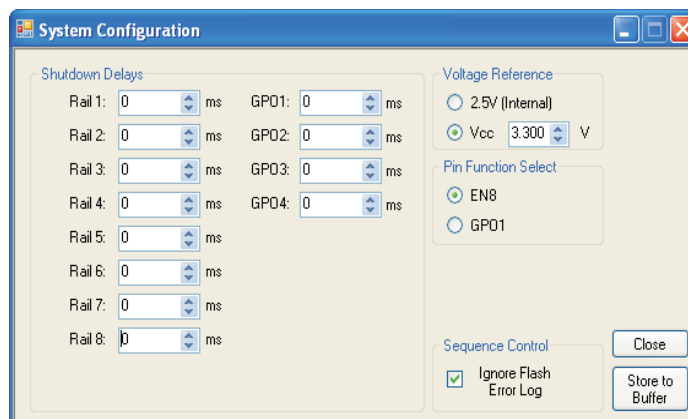

Figure 6. GUI System Configuration Window

- **Shutdown Delays**—specify shutdown delays for rails and GPOs. If a rail or GPO is marked to shut down, then it shuts down according to the shutdown delays entered here. These shutdown delay fields correspond to the UnsequenceTime registers in the UCD9081 device data sheet ([SLVS813](#)).
- **Voltage Reference**—selects the device voltage reference. The UCD9081EVM is configured by default to use the external reference (VCC supply for the sequencer). When VCC is selected as the reference, the GUI provides for actual VCC calibration to be entered. For example, if the actual device VCC voltage is 3.1 V, the GUI can use this to properly scale the displayed voltages.

Note: When the reference is changed and stored to the GUI buffer, the displayed rail voltages are incorrectly scaled, until the device parameters are updated.

- **Pin Function Select**—helps you select the EN8 or GPO1 function. The function selected disables the other function from being configured.
- **Sequence Control**—Checking the Ignore Flash Error Log box allows the sequencer to restart when errors are present in flash. Default operation forces the user to manually clear the flash error before the sequencer will restart.
- **Store to Buffer and Close Buttons**—The Store to Buffer button saves the current window entries to a GUI buffer, and the Close button closes the window without saving the form entries.

3.4 GUI Rail Configuration Window

The Rail Configuration window on the GUI is shown in Figure 7 and permits you to configure these UCD9081 items:

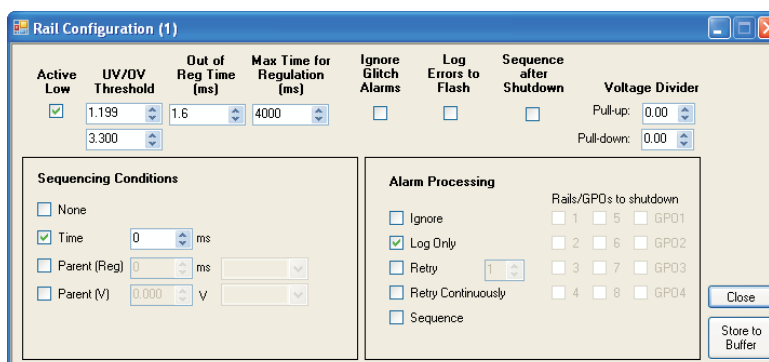

Figure 7. GUI Rail Configuration Window

3.4.1 General Rail Windows Selections

- **Active Low (Polarity)**—specify enable pin polarity.
- **UV/OV Threshold**—specify undervoltage and overvoltage trip points. Note that UV values of zero essentially cause the device to ignore any undervoltage conditions and that OV values which are excessively high cause the device to ignore any overvoltage conditions.
- **Out of Reg Time (ms)**—specify the maximum amount of time (or glitch width) that the rail can be out of the UV/OV range before an alarm is declared.
- **Max Time for Regulation (ms)**—specify the maximum amount of time a rail is allowed to achieve regulation (rail voltage must be within the UV/OV range) before an alarm is declared.
- **Ignore Glitch Alarms**—masks glitches from the Error Log window.
- **Log Errors to Flash**—log rail errors to nonvolatile memory for later evaluation.
- **Sequence After Shutdown**—specify the UCD9081 ENx and GPOx output to be marked to resequence the system (as defined by the current sequencer configuration) if they are specified as a dependency in the DependencyMasks register.
- **Voltage Divider**—specify the user rail voltage divider values. The GUI uses these values to properly scale and display the voltages received through the UCD9081 monitors. Note that zero value divider resistor values cause the divider ratio to be evaluated as unity (no scaling).
- **Store to Buffer and Close Buttons**—The Store to Buffer button saves the current window entries to a GUI buffer and the Close button closes the window without saving the form entries.

3.4.2 Sequencing Conditions Selections

Voltage rail sequencing conditions are:

- **None**—rail is not sequenced.
- **Time**—number of milliseconds before this rail is enabled.
- **Parent (Reg)**—number of milliseconds to delay after the parent rail achieves regulation before enabling this rail.
- **Parent (V)**—voltage at which the parent rail must be before this rail is enabled

3.4.3 Alarm Actions

The alarm actions are:

- **Ignore**—glitch or alarm events are ignored by the device.
- **Log Only**—alarm events are logged only by the device (i.e., no action taken).
- **Retry**—continue to retry a configurable number of times ($n = 0, 1, 2, 3, 4$), then shut down.
- **Retry Continuously**—when an error on the selected rail happens, a retry occurs. A retry is an attempt by the UCD9081 to restart the corresponding power supply by disabling the rail (with ENx pin) and then reenabling the rail. This repeats until the power supply rail alarm clears.
- **Sequence**—when an error occurs on this rail, resequence the system according to the current sequencer configuration.
- **Rails/GPOs to Shutdown**—allows the user to specify which set of rails and GPOs are part of a shutdown event. This is only enabled when a Retry is selected (Retry 0-4).

3.5 GUI GPO Configuration Window

The GPO Configuration window (Figure 8) provides for these UCD9081 configuration settings:

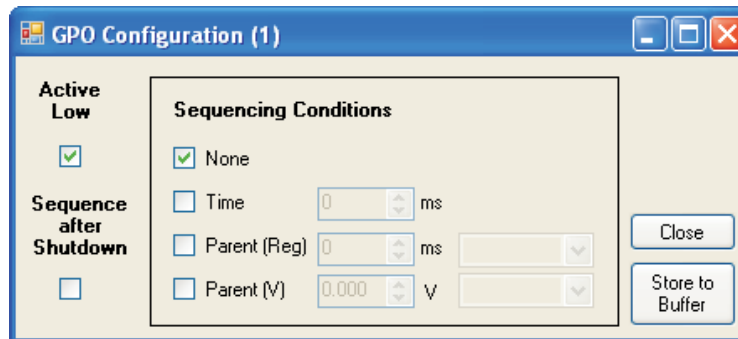

Figure 8. GUI GPO Configuration Window

3.5.1 General GPO Window Selections

- **Active Low (Polarity)**—specifies GPO pin polarity
- **Sequence After Shutdown**—UCD9081 ENx and GPOs output can be marked to resequence the system (as defined by the current sequencer configuration) if they are specified as a dependency in the DependencyMasks register.
- **Store to Buffer and Close Buttons**—The Store to Buffer button saves the current window entries to a GUI buffer, and the Close button closes the window without saving the form entries.

3.5.2 Sequencing Conditions Selections

Sequencing conditions for a GPO:

- **None**—GPO is not sequenced
- **Time**—number of milliseconds before this GPO is enabled
- **Parent (Reg)**—number of milliseconds to delay after the parent rail achieves regulation before enabling this GPO
- **Parent (V)**—voltage at which the parent rail must be before this GPO is enabled

3.6 User Data window

Specific user data can be stored within the UCD9081 device by entering the text in the User Data window as shown in Figure 9.

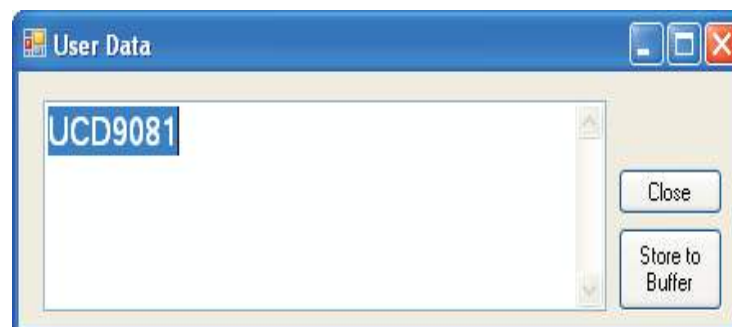

Figure 9. GUI User Data Window

4 EVM Design Configuration Information

4.1 Voltage Rail Set Points

The EVM rail output voltage set points are configurable by changing the output voltage set-point resistors. The UCD9081 directly monitors RAIL1, RAIL2, RAIL3, and RAIL4 (no feedback divider resistors), and these rail output voltages must never be set above the reference voltage being used. RAIL5, RAIL6, RAIL7, and RAIL8 have the feedback divider resistors present and as such, these rail output voltages can be higher than the currently used voltage reference.

- RAIL1 through RAIL6: TPS76201 100-mA LDO

$$V_{\text{RAILx}} = V_{\text{REF}} \times \left(1 + \frac{R_{\text{UP}}}{R_{\text{DN}}} \right); V_{\text{REF}} = 0.6663 \text{ typical for TPS76201}$$

$$\text{Set } R_{\text{DN}} = 66.5 \text{ k}\Omega(\text{max}); R_{\text{Up}} = \left(\frac{V_{\text{RAILx}}}{V_{\text{REF}}} - 1 \right) \times R_{\text{DN}} \quad (1)$$

Note: R_{DN} has been set to 49.9 Ω on the EVM to more quickly discharge the rails during shutdown (see the Rail Bleed-Down Considerations section).

- RAIL7: PTH04070 3-A Switching Regulator

$$\text{Set } R5 = 10 \text{ k}\Omega \times \frac{0.891}{V_{\text{RAIL7}} - 0.891} - 3.24 \text{ k}\Omega \quad (2)$$

- RAIL8: PTH05050 6-A Switching Regulator

$$\text{Set } R2 = 10 \text{ k}\Omega \times \frac{0.8}{V_{\text{RAIL8}} - 0.8} - 2.49 \text{ k}\Omega \quad (3)$$

4.2 Rail Bleed-Down Considerations

When considering system shutdown (or unsequence time), loading on the power supply rails must be taken into account. The rail bleed-down times are a function of the loading and the total (load and power supply) output capacitance. As previously noted for RAIL1-RAIL6, the output voltage set-point resistors have been chosen to provide a much quicker bleed-down time than could be achieved with a light load. For RAIL7 and RAIL8, the feedback divider resistors have been sized to provide more loading for the same reasons. If the user chooses to provide external rail loading, the output voltage set-point resistor values can be adjusted. The EVM rail bleed-down times using the values shown in the bill of materials are on the order of <10 ms, whereas for no-load conditions, the rail bleed-down times can approach several seconds.

4.3 Rail and GUI Divider Selection

Use these equations to choose the external rail and GUI divider resistor values.

Note: Setting R_{pullup} and R_{pulldown} to 0 in the GUI yields a D_{G} value of 1.

- To accurately calculate the correct EVM divider ratio D_{E} the rail, divider resistor, and reference voltage tolerances must be taken into account so that the monitor input voltage does not exceed the device reference voltage.

- Use the following equations to calculate the minimum divider ratio, D_E :

$$\text{Required } D_E = \frac{\left(1 + \frac{\text{TOL}_R}{100}\right) \times V_{\text{RAILE}} \times \left(1 + \frac{\text{TOL}_{\text{RAILE}}}{100}\right)}{V_{\text{REF}} \times \left(1 + \frac{\text{TOL}_{\text{REF}}}{100}\right)}$$

TOL_R = Divider resistor tolerance

$\text{TOL}_{\text{RAILE}}$ = V_{RAILE} tolerance

TOL_{REF} = V_{REF} tolerance

V_{RAILE} = Rail voltage being monitored via divider

V_{REF} = Reference voltage

$R_{\text{PU}} = R_{\text{PD}} \times (D_E - 1)$; Choose $R_{\text{PD}} \leq 10 \text{ k}\Omega$

- EVM Actual Voltages:
 - EVM divider, $D_E = (R_{\text{HI}} + R_{\text{LO}}) / R_{\text{LO}} = 2$
 - RAIL1 through RAIL4: No dividers; $V_{\text{MON}} = V_{\text{RAILE}}$; $V_{\text{MON}} = \text{MONx pin voltage}$, $V_{\text{RAILE}} = \text{EVM RAILx voltage}$
 - RAIL 5 through RAIL8: Divider, $D_E = 2$; $V_{\text{MON}} = V_{\text{RAIL}} / 2$
- GUI Calculated Voltages:
 - GUI divider, $D_G = (R_{\text{PULLDOWN}} + R_{\text{PULLUP}}) / R_{\text{PULLDOWN}}$
 - Displayed rail voltages, $V_{\text{RAILG}} = V_{\text{MON}} \times D_G = V_{\text{RAILE}} \times D_G / D_E$; $V_{\text{RAILG}} = \text{GUI displayed voltage}$

4.4 ENx and GPOx Pin Default Voltage Levels

When the device is reset (see the Reset section), the ENx and GPOx outputs go to a high-impedance state (3-state). Pullup or pulldown resistors on these signals are recommended to cause the signals to go to the desired voltage level during reset. For example, if it is desired to keep a RAILx enabled during reset and the enable is active-low, then a pulldown resistor must be located on the corresponding ENx output. Note that on the EVM, the ENx and GPOx outputs have selectable pullup or pulldown jumpers installed. Also note that for the ENx outputs, the ENx status LEDs provide a stronger pullup current than the jumper pulldowns so that the power supplies become disabled during reset.

4.5 Reset

Device reset occurs when:

- Power is applied to the device (power on reset) or power is cycled.
- The external $\overline{\text{RST}}$ pin is driven low.
- The GUI Update Parameters and Sequence button is pressed, causing new configuration data to be written to the device.
- The GUI Sequence button is pressed, causing the device to sequence.
- A Sequence occurs as a result of a configured rails alarm event.

Any of these reset conditions causes the device I²C address to be re-evaluated. Keep in mind that the EN8/GPO1 pin, as well as GPO2, GPO3, and GPO4 pins, provides the I²C address inputs that are sampled during device reset. If the pin pullup/pulldown configuration jumpers are changed while the GUI is operating and a device reset occurs, then the GUI communication may be affected (perform Discover to re-acquire the EVM I²C address).

5 EVM Schematic

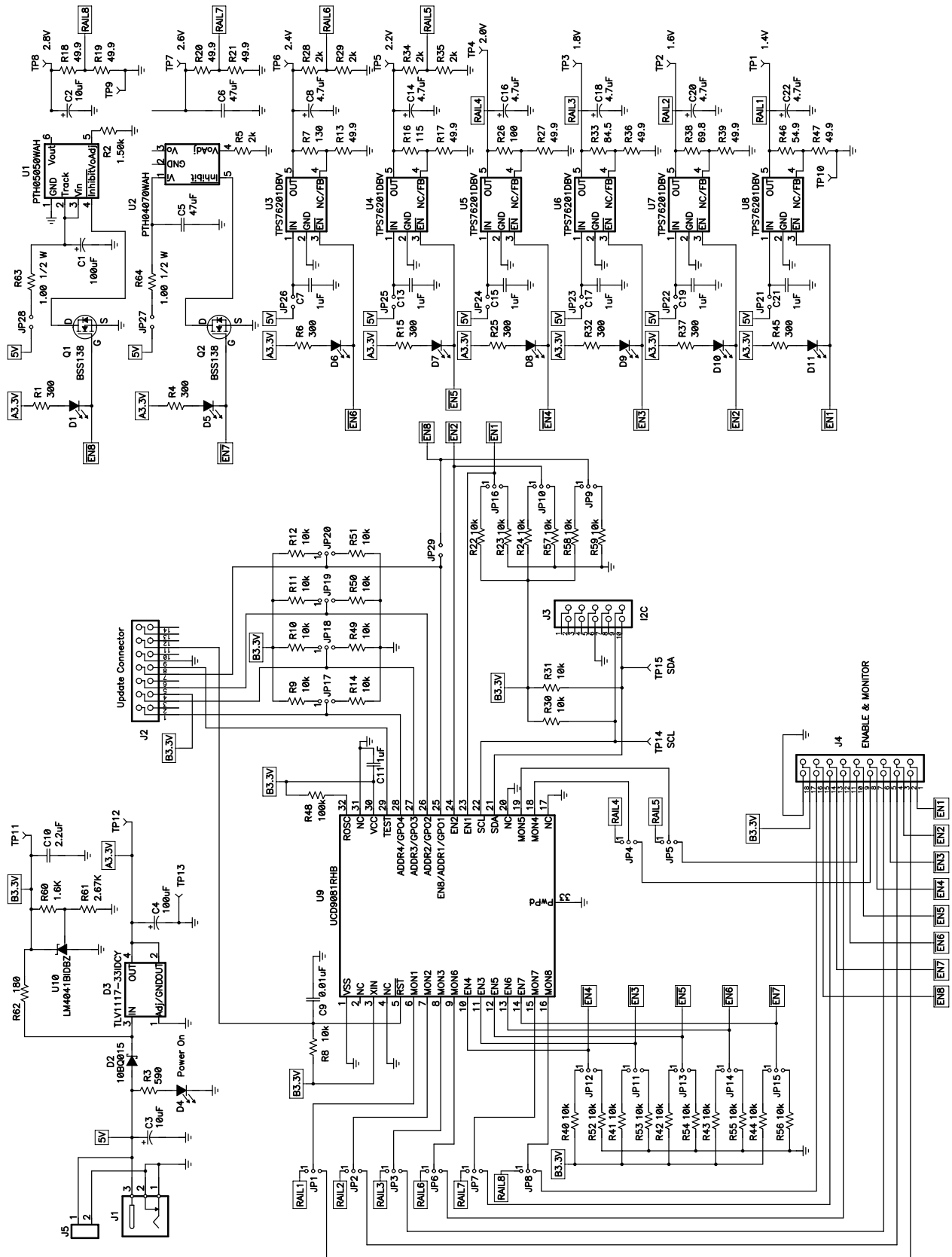

6 Bill of Materials

Count	RefDes	Value	Description	Size	Part Number	MFR
2	C1, C4	100 μ F	Capacitor, Tantalum, 10V, 10%	6032	TAJC107K010R	AVX
1	C10	2.2 μ F	Capacitor, Ceramic, 6.3V, X7R, 20%	0805	STD	Murata
1	C11	1 μ F	Capacitor, Ceramic, 10V, X7R, 20%	0603	STD	Murata
1	C2	10 μ F	Capacitor, Tantalum, 16V, 10%	6032	TAJC106K016R	AVX
1	C3	10 μ F	Capacitor, Tantalum, 10V, 10%	3216	T491A106K010AT	KEMET
2	C5, C6	47 μ F	Capacitor, Ceramic, 6.3V, X5R, 20%	1206	C3216X5R0J476M	TDK
6	C7, C13, C15, C17, C19, C21	1 μ F	Capacitor, Ceramic, 10V, X7R, 20%	0603	STD	Murata
6	C8, C14, C16, C18, C20, C22	4.7 μ F	Capacitor, Tantalum, 6.3V, 20%	0805	TCP0J475M8R	Rohm
1	C9	0.01 μ F	Capacitor, Ceramic, 10V, X7R, 20%	0603	STD	Murata
9	D1, D4–D11		Diode, LED, Red, 100 mA	0805	SML-LXT0805SRW-TR	Lumex
1	D2		Diode, Schottky, 1A, 15V	SMB	10BQ015	IR
1	D3		IC, Adj., 3.3 V, 800mA LDO Voltage Regulators	SOT-223	TLV1117-33CDCY	TI
1	J1		Connector, Pin diameter 2,5 mm, DC Jack	0.57 \times 0.35 inch	RAPC 712	Switchcraft
1	J2		Connector, Male Straight 2 \times 7 pin, 100 mil spacing, 4 Wall	0.100 inch \times 2X7	2514-6002UB	3M
1	J3		Connector, Male Straight 2 \times 10 pin, 100 mil spacing, 4 Wall	0.338 \times 0.788 inch	2510-6002UB	3M
1	J4		Header, 2 \times 9 pin, 100 mil spacing (36 pin strip)	0.100 \times 2 \times 9 inch	PTC36DAAN	Sullins
1	J5		Terminal Block, 2-pin, 15-A, 5,1 mm	0.40 \times 0.35 inch	ED1609	OST
20	JP1–JP20		Header, 3-pin, 100 mil spacing, (36-pin strip)	0.100 inch \times 3	PTC36SAAN	Sullins
9	JP21–JP29		Header, 2-pin, 100 mil spacing, (36-pin strip)	0.100 inch \times 2	PTC36SAAN	Sullins
2	Q1, Q2		MOSFET, Nch, 50V, 0.22A, 3.5 Ω	SOT23	BSS138	Fairchild
8	R1, R4, R6, R15, R25, R32, R37, R45	300	Resistor, Chip, 1/16W, 5%	0603	Std	Std
10	R13, R17, R18–R21, R27, R36, R39, R47	49.9	Resistor, Chip, 1/10W, 1%	0603	Std	Std
1	R16	115	Resistor, Chip, 1/10W, 1%	0603	Std	Std
1	R2	1.50k	Resistor, Chip, 1/16W, 1%	0603	Std	Std
1	R26	100	Resistor, Chip, 1/10W, 1%	0603	Std	Std
1	R3	590	Resistor, Chip, 1/16W, 5%	0603	Std	Std
1	R33	84.5	Resistor, Chip, 1/10W, 1%	0603	Std	Std
1	R38	69.8	Resistor, Chip, 1/10W, 1%	0603	Std	Std
1	R46	54.9	Resistor, Chip, 1/10W, 1%	0603	Std	Std
1	R48	100k	Resistor, Chip, 1/16W, 1%	0603	Std	Std
5	R5, R28, R29, R34, R35	2k	Resistor, Chip, 0.05W, 1%	0603	Std	Std
1	R60	1.6K	Resistor, Chip, 1/16W, 0.1%	0603	Std	Std
1	R61	2.67K	Resistor, Chip, 1/16W, 0.1%	0603	Std	Std
1	R62	180	Resistor, Chip, 1/10W, 1%	0805	Std	Std
2	R63, R64	1.00	Resistor, Chip, 1/2W, 1%	2010	Std	Std
1	R7	130	Resistor, Chip, 1/10W, 1%	0603	Std	Std
27	R8–R12, R14, R22–R24, R30, R31, R40–R44, R49–R59	10k	Resistor, Chip, 1/16W, 5%	0603	Std	Std
12	TP1–TP8, TP11, TP12, TP14, TP15	5012	Test Point, White, Thru Hole	0.125 \times 0.125 inch	5012	Keystone
3	TP9, TP10, TP13	5011	Test Point, Black, Thru Hole	0.125 \times 0.125 inch	5011	Keystone
1	U1		Module, Wide Output Adj, 6A, 0.8V to 3.6V, 5V Input	0.870 \times 0.495	PTH05050WAH	TI
1	U10		IC, Micropower Shunt Voltage Reference 100 ppm/ $^{\circ}$ C, 45 μ A-12 mA, Adjustable	SOT23	LM4041BIDBZ	TI

Count	RefDes	Value	Description	Size	Part Number	MFR
1	U2		Module, 3A, 3.3/5V Input Adjustable Switching Regulator	0.400 × 0.495 inch	PTH04070WAH	TI
6	U3–U8		IC, Micro-Power 100 mA LDO Regulator	SOT23-5	TPS76201DBV	TI
1	U9		IC, Power Supply Sequencer and Monitor	QFN-32	UCD9081RHB	TI
29	—		Shunt, 100-mil, Black	0.1	929950-00	3M
1	—		PCB, 5.3 In × 4.2 In × 0.062 Inch		HPA199	Any
4			Bumpers		2566	SPC

7 Related Documentation From Texas Instruments

- *USB Interface Adapter User's Guide* ([SLLU093](#))
- *8-Channel Power Supply Sequencer and Monitor With Error Logging* data sheet ([SLVS813](#))
- *TPS76901, Ultralow-Power 100-mA Low-Dropout Linear Regulator* data sheet ([SLVS203](#))
- *PTH04070W, 3-A, 3.3/5-V Input Adjustable Switching Regulator* data sheet ([SLTS227](#))
- *PTH05050, 6-A, 5-V Input Non-Isolated Wide-Output Adjust Power Module* data sheet ([SLTS213](#))

EVALUATION BOARD/KIT IMPORTANT NOTICE

Texas Instruments (TI) provides the enclosed product(s) under the following conditions:

This evaluation board/kit is intended for use for **ENGINEERING DEVELOPMENT, DEMONSTRATION, OR EVALUATION PURPOSES ONLY** and is not considered by TI to be a finished end-product fit for general consumer use. Persons handling the product(s) must have electronics training and observe good engineering practice standards. As such, the goods being provided are not intended to be complete in terms of required design-, marketing-, and/or manufacturing-related protective considerations, including product safety and environmental measures typically found in end products that incorporate such semiconductor components or circuit boards. This evaluation board/kit does not fall within the scope of the European Union directives regarding electromagnetic compatibility, restricted substances (RoHS), recycling (WEEE), FCC, CE or UL, and therefore may not meet the technical requirements of these directives or other related directives.

Should this evaluation board/kit not meet the specifications indicated in the User's Guide, the board/kit may be returned within 30 days from the date of delivery for a full refund. **THE FOREGOING WARRANTY IS THE EXCLUSIVE WARRANTY MADE BY SELLER TO BUYER AND IS IN LIEU OF ALL OTHER WARRANTIES, EXPRESSED, IMPLIED, OR STATUTORY, INCLUDING ANY WARRANTY OF MERCHANTABILITY OR FITNESS FOR ANY PARTICULAR PURPOSE.**

The user assumes all responsibility and liability for proper and safe handling of the goods. Further, the user indemnifies TI from all claims arising from the handling or use of the goods. Due to the open construction of the product, it is the user's responsibility to take any and all appropriate precautions with regard to electrostatic discharge.

EXCEPT TO THE EXTENT OF THE INDEMNITY SET FORTH ABOVE, NEITHER PARTY SHALL BE LIABLE TO THE OTHER FOR ANY INDIRECT, SPECIAL, INCIDENTAL, OR CONSEQUENTIAL DAMAGES.

TI currently deals with a variety of customers for products, and therefore our arrangement with the user **is not exclusive.**

TI assumes **no liability for applications assistance, customer product design, software performance, or infringement of patents or services described herein.**

Please read the User's Guide and, specifically, the Warnings and Restrictions notice in the User's Guide prior to handling the product. This notice contains important safety information about temperatures and voltages. For additional information on TI's environmental and/or safety programs, please contact the TI application engineer or visit www.ti.com/esh.

No license is granted under any patent right or other intellectual property right of TI covering or relating to any machine, process, or combination in which such TI products or services might be or are used.

FCC Warning

This evaluation board/kit is intended for use for **ENGINEERING DEVELOPMENT, DEMONSTRATION, OR EVALUATION PURPOSES ONLY** and is not considered by TI to be a finished end-product fit for general consumer use. It generates, uses, and can radiate radio frequency energy and has not been tested for compliance with the limits of computing devices pursuant to part 15 of FCC rules, which are designed to provide reasonable protection against radio frequency interference. Operation of this equipment in other environments may cause interference with radio communications, in which case the user at his own expense will be required to take whatever measures may be required to correct this interference.

EVM WARNINGS AND RESTRICTIONS

It is important to operate this EVM within the input voltage range of 0 V to 5 V and the output voltage range of 0 V to 3.3 V.

Exceeding the specified input range may cause unexpected operation and/or irreversible damage to the EVM. If there are questions concerning the input range, please contact a TI field representative prior to connecting the input power.

Applying loads outside of the specified output range may result in unintended operation and/or possible permanent damage to the EVM. Please consult the EVM User's Guide prior to connecting any load to the EVM output. If there is uncertainty as to the load specification, please contact a TI field representative.

During normal operation, some circuit components may have case temperatures greater than 50°C. The EVM is designed to operate properly with certain components above 50°C as long as the input and output ranges are maintained. These components include but are not limited to linear regulators, switching transistors, pass transistors, and current sense resistors. These types of devices can be identified using the EVM schematic located in the EVM User's Guide. When placing measurement probes near these devices during operation, please be aware that these devices may be very warm to the touch.

Mailing Address: Texas Instruments, Post Office Box 655303, Dallas, Texas 75265
Copyright © 2008, Texas Instruments Incorporated

IMPORTANT NOTICE

Texas Instruments Incorporated and its subsidiaries (TI) reserve the right to make corrections, modifications, enhancements, improvements, and other changes to its products and services at any time and to discontinue any product or service without notice. Customers should obtain the latest relevant information before placing orders and should verify that such information is current and complete. All products are sold subject to TI's terms and conditions of sale supplied at the time of order acknowledgment.

TI warrants performance of its hardware products to the specifications applicable at the time of sale in accordance with TI's standard warranty. Testing and other quality control techniques are used to the extent TI deems necessary to support this warranty. Except where mandated by government requirements, testing of all parameters of each product is not necessarily performed.

TI assumes no liability for applications assistance or customer product design. Customers are responsible for their products and applications using TI components. To minimize the risks associated with customer products and applications, customers should provide adequate design and operating safeguards.

TI does not warrant or represent that any license, either express or implied, is granted under any TI patent right, copyright, mask work right, or other TI intellectual property right relating to any combination, machine, or process in which TI products or services are used. Information published by TI regarding third-party products or services does not constitute a license from TI to use such products or services or a warranty or endorsement thereof. Use of such information may require a license from a third party under the patents or other intellectual property of the third party, or a license from TI under the patents or other intellectual property of TI.

Reproduction of TI information in TI data books or data sheets is permissible only if reproduction is without alteration and is accompanied by all associated warranties, conditions, limitations, and notices. Reproduction of this information with alteration is an unfair and deceptive business practice. TI is not responsible or liable for such altered documentation. Information of third parties may be subject to additional restrictions.

Resale of TI products or services with statements different from or beyond the parameters stated by TI for that product or service voids all express and any implied warranties for the associated TI product or service and is an unfair and deceptive business practice. TI is not responsible or liable for any such statements.

TI products are not authorized for use in safety-critical applications (such as life support) where a failure of the TI product would reasonably be expected to cause severe personal injury or death, unless officers of the parties have executed an agreement specifically governing such use. Buyers represent that they have all necessary expertise in the safety and regulatory ramifications of their applications, and acknowledge and agree that they are solely responsible for all legal, regulatory and safety-related requirements concerning their products and any use of TI products in such safety-critical applications, notwithstanding any applications-related information or support that may be provided by TI. Further, Buyers must fully indemnify TI and its representatives against any damages arising out of the use of TI products in such safety-critical applications.

TI products are neither designed nor intended for use in military/aerospace applications or environments unless the TI products are specifically designated by TI as military-grade or "enhanced plastic." Only products designated by TI as military-grade meet military specifications. Buyers acknowledge and agree that any such use of TI products which TI has not designated as military-grade is solely at the Buyer's risk, and that they are solely responsible for compliance with all legal and regulatory requirements in connection with such use.

TI products are neither designed nor intended for use in automotive applications or environments unless the specific TI products are designated by TI as compliant with ISO/TS 16949 requirements. Buyers acknowledge and agree that, if they use any non-designated products in automotive applications, TI will not be responsible for any failure to meet such requirements.

Following are URLs where you can obtain information on other Texas Instruments products and application solutions:

Products

Amplifiers	amplifier.ti.com
Data Converters	dataconverter.ti.com
DSP	dsp.ti.com
Clocks and Timers	www.ti.com/clocks
Interface	interface.ti.com
Logic	logic.ti.com
Power Mgmt	power.ti.com
Microcontrollers	microcontroller.ti.com
RFID	www.ti-rfid.com
RF/IF and ZigBee® Solutions	www.ti.com/lprf

Applications

Audio	www.ti.com/audio
Automotive	www.ti.com/automotive
Broadband	www.ti.com/broadband
Digital Control	www.ti.com/digitalcontrol
Medical	www.ti.com/medical
Military	www.ti.com/military
Optical Networking	www.ti.com/opticalnetwork
Security	www.ti.com/security
Telephony	www.ti.com/telephony
Video & Imaging	www.ti.com/video
Wireless	www.ti.com/wireless

Mailing Address: Texas Instruments, Post Office Box 655303, Dallas, Texas 75265
Copyright © 2008, Texas Instruments Incorporated