

REV.	DESCRIPTION	DATE	APPROVED
B	Engineering Release	02/27/15	J. C.
C	Revised Side View, See Page 4	03/20/15	J. C.
D	Corrected Typo in Recom. Soldering Pattern	09/12/16	J. C.

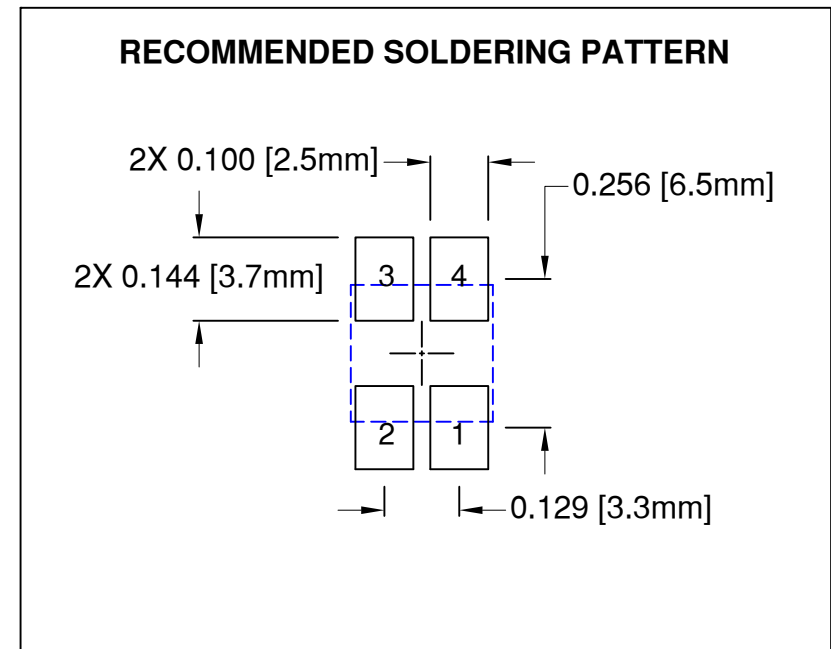
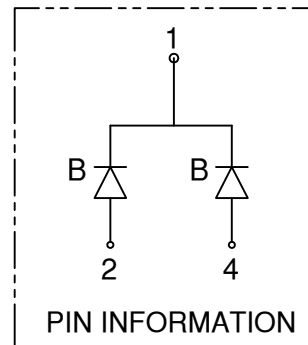
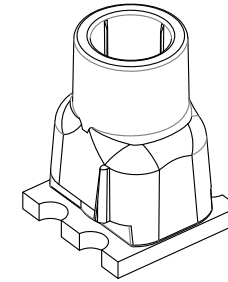
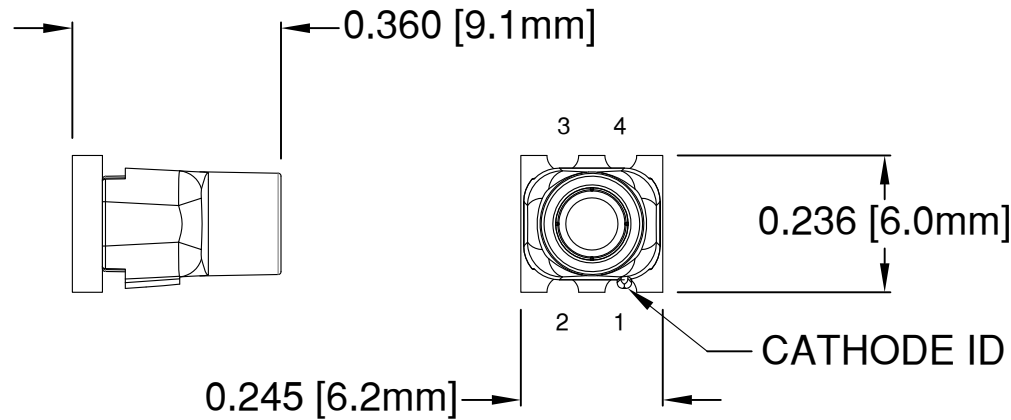

ABSOLUTE MAXIMUM RATINGS at Ta=25°C

REVERSE VOLTAGE	5V
REVERSE CURRENT	100µA
OPERATING TEMPERATURE RANGE	-35°C - 85°C
STORAGE TEMPERATURE	-35°C - 85°C
MAX SOLDERING TEMPERATURE	260°C FOR 3 SECONDS

NOTES:



- DERATING OF FORWARD CURRENT PER SEGMENT, 0.30mA/°C at T ≥ 25°C
- ACCEPTS BIVAR FLEXIBLE LIGHT PIPE STYLE FLPS2031

STANDARD TOLERANCE (UNLESS OTHERWISE SPECIFIED)		 4 THOMAS, IRVINE, CA. 92618 TEL: (949) 951-8808 FAX: (949) 951-3974	
DECIMALS	ANGULAR		
.X ± .1	X° ± 1°	TITLE: SMT FLP VERTICAL ADAPTER, BLUE	
.XX ± .02			
.XXX ± .010			
DESIGNED: A. Wright	DATE: 03/13/14	PART NO: SMTV01-BXX	REVISION: D
CHECKED: B. Oliver	DATE: 03/13/14	CAGE CODE : 32559	SHEET # 1 OF 4
CAD GENERATED DOCUMENT. DO NOT MEASURE DRAWING.			

REV.	DESCRIPTION	DATE	APPROVED
	SEE SHEET #1		

Part Number	Chip				Absolute Maximum Ratings Per Segment			Electro-Optical Data @40mA, 25°C			
	Emitted Color	λ_D [nm]			P_d [mW]	I_f [mA]	Peak I_f [mA]	V_f [V]			I_v [mcd]
		MIN	TYP	MAX				MIN	TYP	MAX	TYP
SMTV01-B11	BLUE	460	465	470	100	25	100	2.8	3.3	3.8	110
SMTV01-B16					100	25	100				161
SMTV01-B19					100	25	100				187

Note: 10% Duty Cycle, Pulse Width ≤ 0.1 msec for Peak I_f .

STANDARD TOLERANCE (UNLESS OTHERWISE SPECIFIED)		 4 THOMAS, IRVINE, CA. 92618 TEL: (949) 951-8808 FAX: (949) 951-3974	
DECIMALS	ANGULAR		
.X ± .1	X° ± 1°		TITLE: SMT FLP VERTICAL ADAPTER, BLUE
.XX ± .02			DESIGNED: A. Wright
.XXX ± .010		CHECKED: B. Oliver	DATE: 03/13/14
		PART NO: SMTV01-BXX	REVISION: D
		CAGE CODE : 32559	SHEET # 2 OF 4
CAD GENERATED DOCUMENT, DO NOT MEASURE DRAWING.			

REV.	DESCRIPTION	DATE	APPROVED
	SEE SHEET #1		

Recommended Reflow Soldering Profile

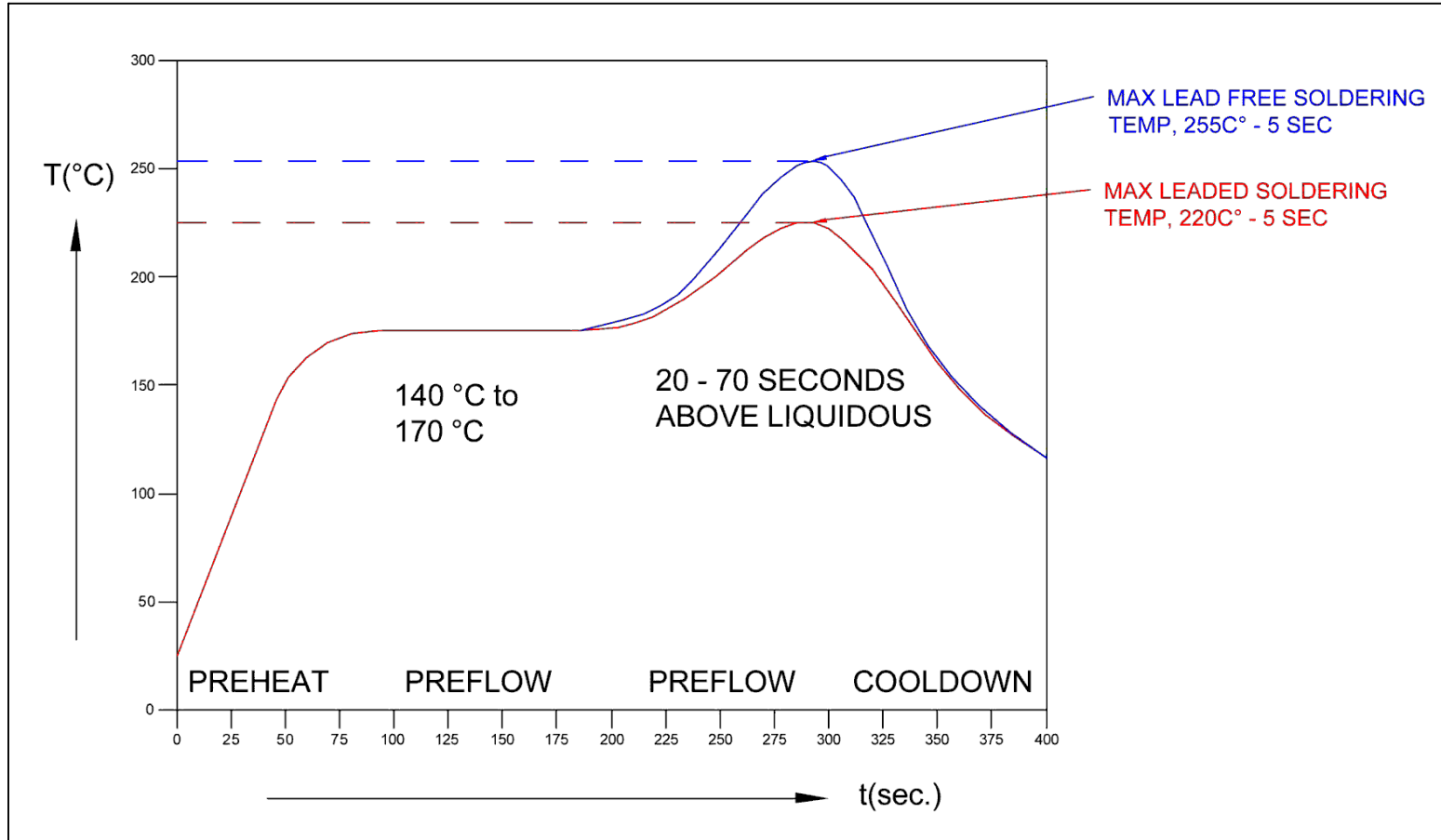

NOTE:
1. Do not clean after soldering. Only use no-clean solder paste.

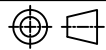
STANDARD TOLERANCE (UNLESS OTHERWISE SPECIFIED)		 BIVAR [®] 4 THOMAS, IRVINE, CA. 92618 TEL: (949) 951-8808 FAX: (949) 951-3974	
DECIMALS	ANGULAR		
.X ± .1	X° ± 1°	 TITLE: SMT FLP VERTICAL ADAPTER , BLUE	
.XX ± .02			
.XXX ± .010		PART NO: SMTV01-BXX	
DESIGNED: A. Wright	DATE: 03/13/14	REVISION: D	
CHECKED: B. Oliver	DATE: 03/13/14	CAGE CODE : 32559 SHEET # 3 OF 4	
CAD GENERATED DOCUMENT. DO NOT MEASURE DRAWING.			

REV.	DESCRIPTION	DATE	APPROVED
	SEE SHEET #1		

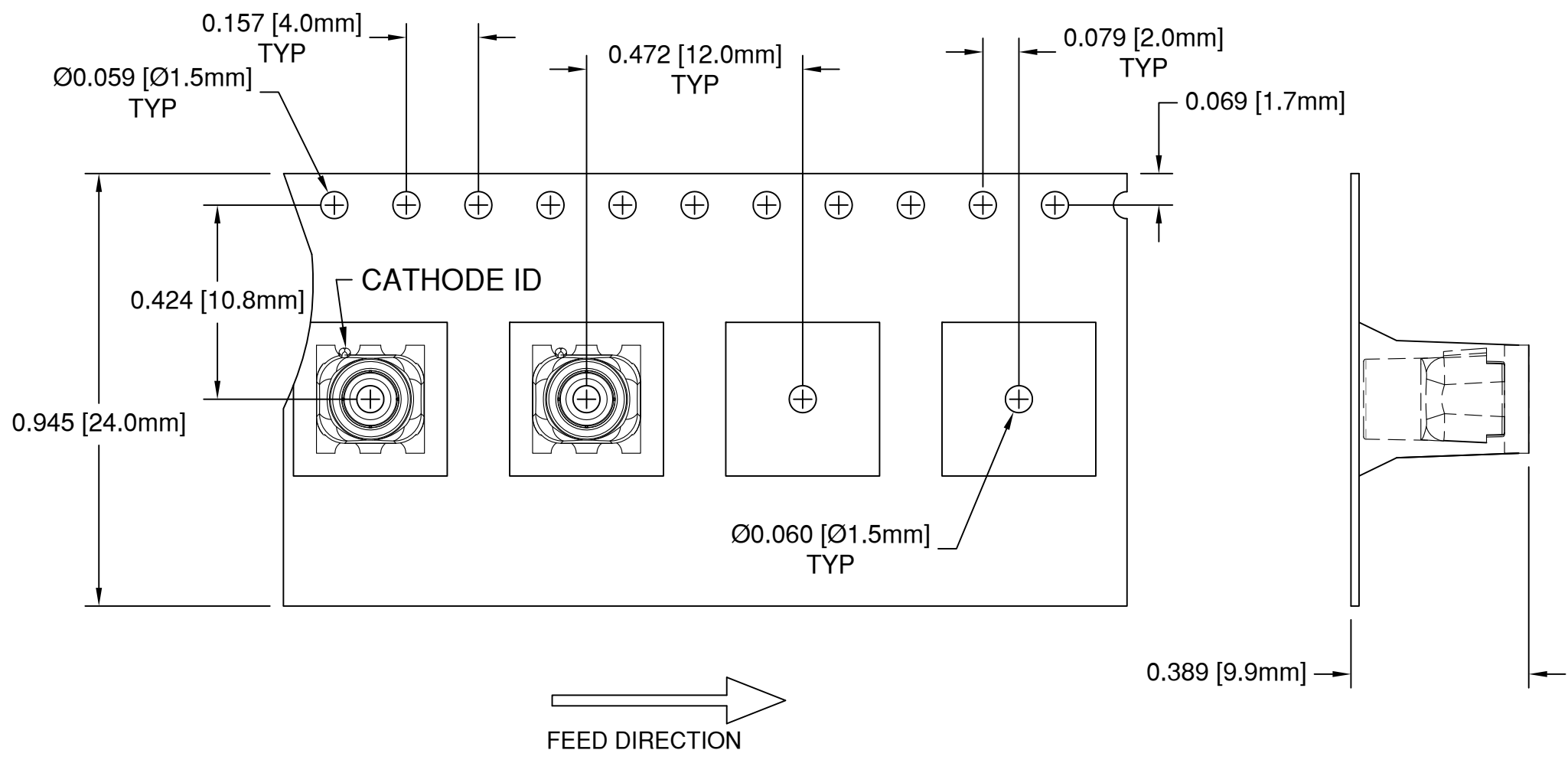

NOTES:
 3. MOISTURE SENSITIVITY LEVEL: 4
 2. UNLESS OTHERWISE SPECIFIED, PACKAGING TO COMPLY WITH EIA-481-D
 1. 500 pcs PER REEL

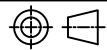
STANDARD TOLERANCE (UNLESS OTHERWISE SPECIFIED)		 4 THOMAS, IRVINE, CA. 92618 TEL: (949) 951-8808 FAX: (949) 951-3974	
DECIMALS	ANGULAR		
.X ± .1	X° ± 1°		TITLE: SMT FLP VERTICAL ADAPTER, BLUE
.XX ± .02			PART NO: SMTV01-BXX
.XXX ± .010		DESIGNED: A. Wright	DATE: 03/13/14
		CHECKED: B. Oliver	DATE: 03/13/14
		CAGE CODE : 32559	SHEET # 4 OF 4
CAD GENERATED DOCUMENT. DO NOT MEASURE DRAWING.			