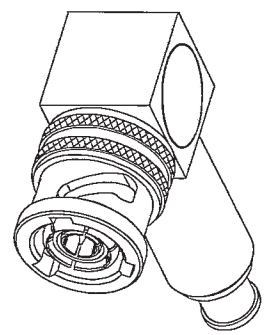
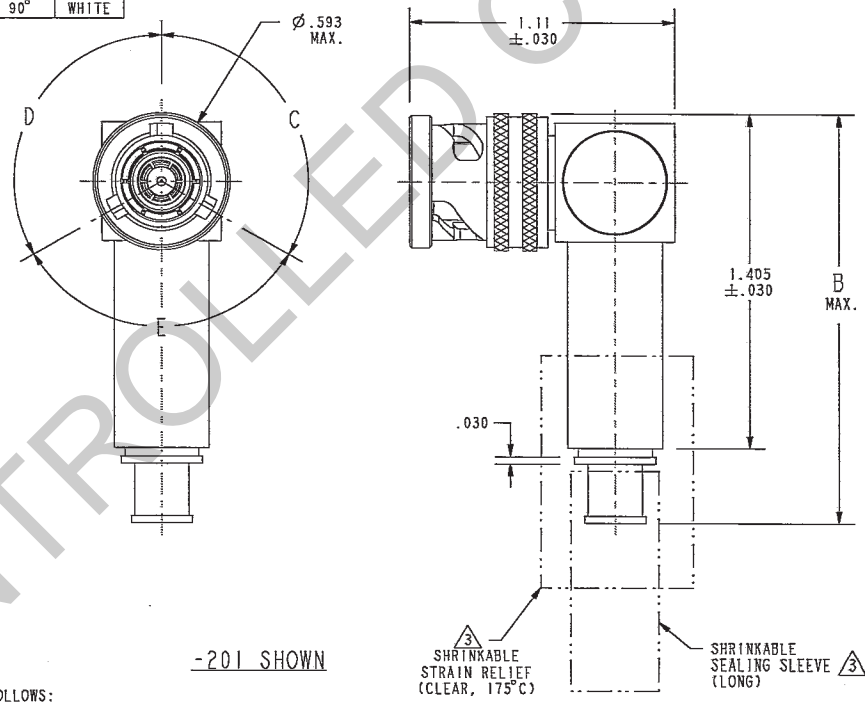

TABLE 1				
DASH NUMBER	CABLES ACCOMMODATED	A HEX	B DIM	ASSEMBLY PER
-201	M171176-00002	.344	1.76	TAI-169
-202	TWC-78-1			
-203	TWC-124-1A			
-204	10602, RAYCHEM			
-205	TWAC-78-1F2			
-206	7826D0130, RAYCHEM			
-207	83310 BELDEN			
-208	202-3927, MICRODOT			
-209	202-3942, MICRODOT			
-210	8451 BELDEN			
-211	202-3934 MICRODOT	1.47	TAI-161	
-212	2524E0114, RAYCHEM			
-213	TWC-78-2			
-214	TWC-124-2			
-215	BL-982 TIMES	1.76	TAI-169	
-216	BL-1242 TIMES			
-217	GC875TM24H, GRUMMAN			
-218	EPD221888, RAYCHEM			
-219	2526D1114, RAYCHEM			
-220	GC875RR1, GRUMMAN			
-221	10614, RAYCHEM			
-222	10613, RAYCHEM			
-223	HMS2-1149, HUGHES			
-224	TWCP-124-3			
-225	PS665PL, PRIME STOCK	1.47	TAI-161	
-301	GC875GC1, GRUMMAN			
-302	GC875GB1, GRUMMAN			
-303	7528A5314, RAYCHEM			
-304		1.76	TAI-154	
-305	M171177-00001 THERMATICS			
-306	TRC-50-2 M171134-00002			
-307	TRC-75-1			
-308	TRC-75-2	1.76	TAI-154	
		1.47	TAI-178	
-309	TRC-50-1	1.76	TAI-154	

TABLE 2				
POLARIZATION CHART				
KEYING LETTER	C DEGREES	D DEGREES	E DEGREES	COLOR BAND
NONE	120°	120°	120°	NONE
T	100°	150°	110°	RED
U	120°	130°	110°	ORANGE
V	115°	130°	115°	YELLOW
W	125°	110°	125°	GREEN
X	130°	100°	130°	BLUE
Y	110°	140°	110°	VIOLET
Z	100°	160°	100°	GRAY
S	135°	135°	90°	WHITE

DATA CONTAINED IN THIS DOCUMENT IS PROPRIETARY OF TROMPETER ELECTRONICS INC. AND SHALL NOT BE DISCLOSED, COPIED OR USED FOR PROCUREMENT OR MANUFACTURE WITHOUT EXPRESS WRITTEN PERMISSION.

REVISIONS			
REV	DESCRIPTION	DATE	APPROVED
W	REVISED PER ECO 16072		



SCALE 2/1

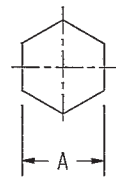

RECOMMENDED HEX CRIMP

4. EXAMPLE OF COMPLETE MODEL NUMBER:

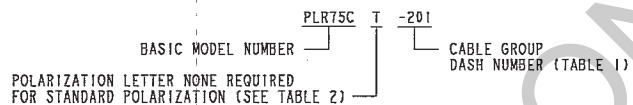

-201 SHOWN

3. SHRINKABLE STRAIN RELIEF AND/OR SHRINKABLE SEALING SLEEVE SUPPLIED LOOSE AS FOLLOWS:

- a. CABLE GROUPS -201 THROUGH -210, -217 THROUGH -303, -305, -307 AND -309
 - 1 SHRINKABLE STRAIN RELIEF (1.00 LONG)
 - 1 SHRINKABLE SEALING SLEEVE (1.25 LONG)
- b. CABLE GROUPS -211 THROUGH -216, -306 AND -308
 - 1 SHRINKABLE STRAIN RELIEF (1.75 LONG)

2. 3-LUG BAYONET CONCENTRIC TWINAX/TRIAX TRB RIGHT ANGLE FULL CRIMP CABLE PLUG

- 1. TFS-1A (NICKEL)

NOTES: UNLESS OTHERWISE SPECIFIED.

RED INDICATES ORIGINAL

INTERPRET DRAWING PER MIL-STD-100. DIMENSIONS ARE IN INCHS AND INCLUDE FINISH THICKNESS UNLESS OTHERWISE SPECIFIED.		TOL: UNLESS SPECIFIED .XX ± .02 .XXX ± .010 ANGLE ± 1°			
DATE	2-9-08	MATERIAL		TITLE: PLR75C /T/U/V/W/X/Y/Z/S	
QUALITY	CTS 2/2/06	FINISH		SIZE	B
MADE				CAGE CODE	14949
APPROVED				DRAWING NO.	310-0066
PROJ FILE NO.	310-0066	DO NOT SCALE DWG	SCALE	2/1	DATE
					7-28-87
				SHEET	1C