

**Vacuum Fluorescent Display  
Module  
Specification**

Model: CU20027-Y100

Specification No: DS-1571-0001-00  
Date of Issue: January 29, 2009 (00)  
Revision:

Published by  
NORITAKE ITRON CORP. / Japan  
<http://www.noritake-itron.jp>

This specification is subject to change without prior notice.

**This product complies with RoHS Directive 2002/95/EC**

Index.

<b>1</b>	<b>General Description .....</b>	<b>3</b>
1.1	Scope .....	3
1.2	Features.....	3
1.3	Hardware Configuration .....	4
1.3.1	Block Diagram .....	4
<b>2</b>	<b>Electrical Specification.....</b>	<b>4</b>
2.1	Absolute Maximum Ratings.....	4
2.2	Electrical Ratings.....	4
2.3	Electrical Characteristics.....	5
<b>3</b>	<b>Optical Specifications.....</b>	<b>6</b>
<b>4</b>	<b>Environmental Specifications.....</b>	<b>6</b>
<b>5</b>	<b>Physical Specifications .....</b>	<b>6</b>
<b>6</b>	<b>Applicable Specifications .....</b>	<b>6</b>
<b>7</b>	<b>Interface.....</b>	<b>6</b>
7.1	Parallel Interface.....	7
7.1.1	Basic Operation.....	7
7.1.2	Flowchart .....	7
7.1.3	Interface Timing.....	8
7.2	Serial Interface.....	9
7.2.1	Basic Operation.....	9
7.2.2	Flowchart .....	9
7.2.3	Asynchronous Serial Interface Timing.....	10
7.2.3.1	Data write .....	10
7.2.3.2	Data read.....	10
7.3	Reset Timing.....	11
<b>8</b>	<b>Jumper Setting .....</b>	<b>12</b>
8.1	Jumper location .....	12
8.1.1	Baud Rate Setting (for Asynchronous Serial Interface only).....	12
8.1.2	Test Mode.....	12
<b>9</b>	<b>Operating Mode .....</b>	<b>13</b>
9.1	Direct Command Mode .....	13
9.2	User Set up Mode .....	13
9.3	Serial OUT Mode.....	13
9.4	Test mode.....	13
<b>10</b>	<b>Font Table Configuration .....</b>	<b>14</b>
<b>11</b>	<b>Display Area-End of Line Behavior .....</b>	<b>15</b>
<b>12</b>	<b>Initial setting.....</b>	<b>16</b>
<b>13</b>	<b>Commands.....</b>	<b>16</b>
13.1	Command Configuration .....	16
13.2	Command Set.....	17
13.3	Detail of Command Set .....	18
13.3.1	Character display .....	18
13.3.2	Back Space.....	19
13.3.3	Horizontal Tab.....	19
13.3.4	Line Feed .....	20
13.3.5	Home Position.....	20
13.3.6	Display Clear .....	21

13.3.7	Carriage Return.....	21
13.3.8	Underline cursor mode.....	21
13.3.9	Cursor off mode.....	21
13.3.10	Block cursor mode.....	21
13.3.11	Underline cursor blink mode.....	21
13.3.12	Cursor set.....	21
13.3.13	Initialize display.....	22
13.3.14	RAM user font.....	22
13.3.15	Define RAM user font.....	23
13.3.16	Delete RAM user font.....	24
13.3.17	Character blink mode OFF.....	24
13.3.18	Character blink mode ON.....	24
13.3.19	Specify quick write mode.....	24
13.3.20	Specify International font set.....	25
13.3.21	Specify flickerless write mode.....	25
13.3.22	Blink speed control.....	26
13.3.23	Underline display mode ON.....	26
13.3.24	Underline display mode OFF.....	26
13.3.25	Insert character.....	26
13.3.26	Delete character.....	27
13.3.27	Insert line.....	27
13.3.28	Delete line.....	27
13.3.29	Reset.....	27
13.3.30	Specify character code type.....	27
13.3.31	Over-write mode.....	28
13.3.32	Vertical scroll mode.....	28
13.3.33	Horizontal scroll mode.....	28
13.3.34	Horizontal scroll speed.....	28
13.3.35	Brightness level setting.....	28
13.3.36	Wait.....	29
13.3.37	Display blink.....	29
13.3.38	Screen saver.....	30
13.3.39	User set up mode start.....	30
13.3.40	User set up mode end.....	30
13.3.41	Define FROM user font.....	31
13.3.42	Read Status information.....	32
13.3.43	Display Status information.....	32
13.3.44	Serial OUT mode start.....	32
13.3.45	Serial OUT mode end.....	33
13.3.46	Select / Deselect 5×8 Matrix font.....	33
13.3.47	Select/Deselect Alternative Magnified Font.....	34
13.3.48	Font Magnification.....	35
13.3.49	Individual Character Brightness Level Setting.....	36
<b>14</b>	<b>Pin Configuration.....</b>	<b>37</b>
14.1	<i>Parallel interface connector (Fourteen through-holes / CN1).....</i>	37
14.2	<i>Serial interface connector (Six through-holes / CN3).....</i>	37
<b>15</b>	<b>Firmware Version Notation.....</b>	<b>37</b>
<b>16</b>	<b>Physical Dimensions.....</b>	<b>38</b>
	<b>Notice for the Cautious Handling VFD Modules.....</b>	<b>39</b>
	<b>Revision Note.....</b>	<b>40</b>

# 1 General Description

## 1.1 Scope

This specification covers the operation and operating requirements of the Vacuum Fluorescent Display (VFD) module CU20027-Y100.

## 1.2 Features

- Functions
  - Character highlight
  - Easy to use ASCII commands and fonts.
  - Character Magnification
  - Screen Saver
  - Blink Action Command(Display or Character)
- Display
  - Vivid green indication
  - Wider viewing angle
  - High Brightness (Typ. 2000 cd/m<sup>2</sup>)
  - Brightness Levels: 8 levels of overall display brightness with 8 relative levels for each individual 5×8 Matrix
- Font
  - New 5×8 Matrix Character Font
  - Many International Font Sets
  - RAM User-Definable Characters (16 characters)
  - FROM User-Definable Characters (224 characters)
  - 40 (20×2) Characters on the compact display area
- Interface
  - Parallel Interface: i80 type 8bit bus(C MOS Signal level)
  - Serial Interface: Asynchronous(RS232 level)
- Operation
  - DC 5V input
  - Wide Operation Temperature Range (-40 ~ +85°C)

### 1.3 Hardware Configuration

The module consists of:  
 20 x 2 character Display (VFD)  
 Refresh RAM  
 Character generator  
 DC/DC converter (Supply all necessary power for VFD)  
 Display controller  
 All necessary control logic circuits

#### 1.3.1 Block Diagram

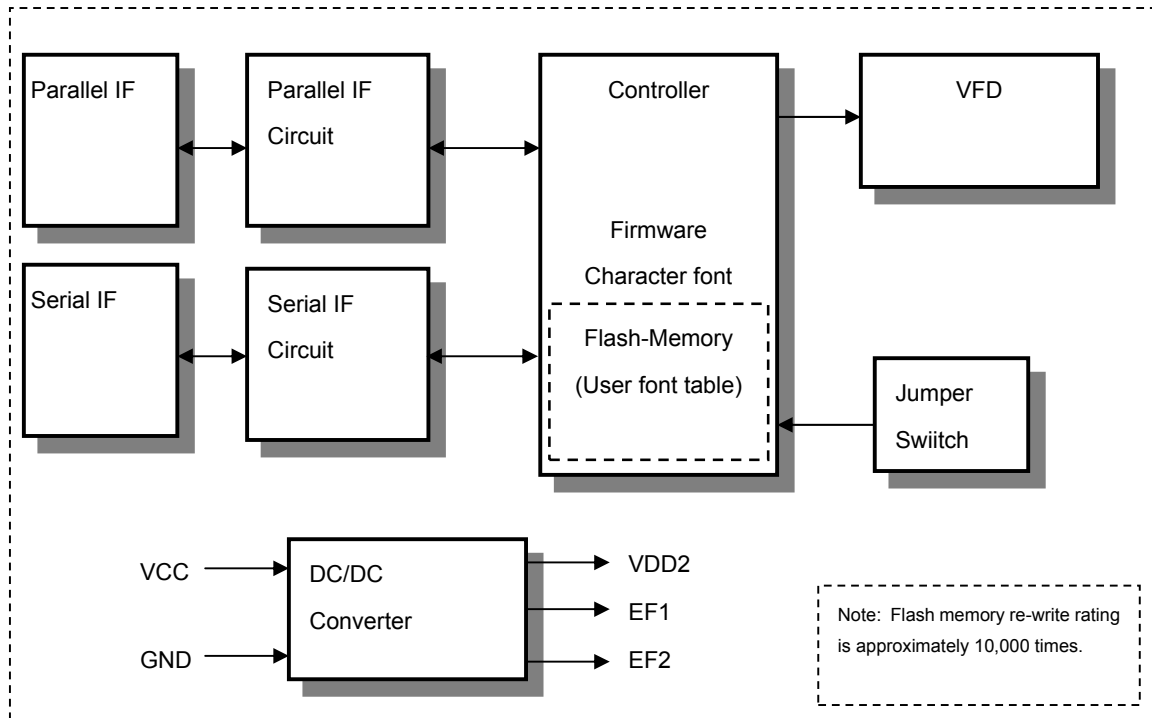

## 2 Electrical Specification

### 2.1 Absolute Maximum Ratings

Parameter	Symbol	Min.	Typ.	Max.	Unit
Power Supply Voltage	$V_{CC}$	-0.3	-	+6.0	$V_{DC}$
Logic Supply Voltage D0-D7, /WR, /RESET	$V_{IN}$	-0.3	-	$V_{CC}+0.3$	$V_{DC}$
Logic Supply Voltage SIN	$V_{IN}$	-20.0	-	+20.0	$V_{DC}$

### 2.2 Electrical Ratings

Parameter	Symbol	Min.	Typ.	Max.	Unit
Power Supply Voltage	$V_{CC}$	4.75	5.0	5.25	$V_{DC}$

## 2.3 Electrical Characteristics

Measuring Conditions: Ambient temperature = 25 °C,  $V_{CC} = 5.0 V_{DC}$

Parameter		Symbol	Min.	Typ.	Max.	Unit	Condition	Note
'L' Level Logic Input Current	D0-D7, /WR, /RESET	$I_{IL}$	-	-	-0.15	mA	$V_{IN} = 0V$	-
	D0-D7	$I_{IH1}$	-	-	5.0	$\mu A$	$V_{IN} = 5V$	-
'H' Level Logic Input Current	/WR, /RESET	$I_{IH2}$	-	-	0.25	$\mu A$	$V_{IN} = 5V$	-
	SIN	$R_{IN}$	3	-	-	KOhm	-	-
'L' Level Logic Input Voltage	D0-D7, /WR	$V_{IL1}$	0	-	$0.2 \times V_{CC}$	$V_{DC}$	-	-
	/RESET	$V_{IL2}$	0	-	0.8	$V_{DC}$	-	-
	SIN	$V_{IL3}$	-15	-	0.5	$V_{DC}$	-	-
'H' Level Logic Input Voltage	D0-D7, /WR, /RESET,	$V_{IH1}$	$0.8 \times V_{CC}$	-	$V_{CC}$	$V_{DC}$	-	-
	SIN	$V_{IH2}$	3.0	-	+15	$V_{DC}$	-	-
'L' Level Logic Output Voltage	PBUSY	$V_{OL1}$	-	-	0.1	$V_{DC}$	$I_{OL} = 50\mu A$	-
	SBUSY	$V_{OL2}$	0	-	0.5	$V_{DC}$	$R_L = 3KOhm$	-
'H' Level Logic Output Voltage	PBUSY	$V_{OH1}$	$V_{CC}-0.1$	-	-	$V_{DC}$	$I_{OH} = -50\mu A$	-
	SBUSY	$V_{OH2}$	4.0	-	$V_{CC}$	$V_{DC}$	$R_L = 3KOhm$	-
Power Supply Current		$I_{CC1-1}$	-	240	300	$mA_{DC}$	Brightness 100%	(1)
		$I_{CC2-1}$	-	200	250	$mA_{DC}$	Brightness 100%	(2)
		$I_{CC1-2}$	-	320	400	$mA_{DC}$	Brightness 200%	(1)
		$I_{CC2-2}$	-	250	310	$mA_{DC}$	Brightness 200%	(2)
		$I_{CC3}$	-	25	35	$mA_{DC}$	Power Save Mode	(3)
Power Consumption		-	-	1.2	1.5	W	Brightness 100%	(1)
		-	-	1.6	2.0	W	Brightness 200%	(1)

(1)  $I_{CC1}$  shows the current when all dots in the display are on.

(2)  $I_{CC2}$  shows the current when all dots in the display are off.

(3)  $I_{CC3}$  shows the current with the Power Save Mode. Power save mode is one of the options of "Screen saver" command. Please refer to "Screen saver" command at Page 30.

**Note: A slow start power supply may cause erroneous operations.  $I_{CC}$  can be approximately twice the specified supply current at power on.**

### 3 Optical Specifications

Luminance:	Minimum 350 cd/m <sup>2</sup> , typically 1000 cd/m <sup>2</sup> (100% brightness) Typically 2000 cd/m <sup>2</sup> (200% brightness)
Color of illumination:	Green (Blue Green)

### 4 Environmental Specifications

Operating temperature:	-40 to +85 °C
Storage temperature:	-40 to +85 °C
Operating humidity:	20 to 80 % R.H (non-condensing)
Storage humidity:	20 to 80 % R.H (non-condensing)
Vibration:	10-55-10Hz, all amplitude 1mm, 30 minutes, X-Y-Z (non-operating)
Shock:	392m/s <sup>2</sup> (40G) 9ms X-Y-Z, 3 times each direction (non-operating)

### 5 Physical Specifications

Number of characters:	40 (20 characters x 2 lines)
Matrix format:	5 × 8 dots
Display area:	73.4 x 15.0 mm (X × Y)
Character size:	2.72 x 7.19 mm (X × Y)
Character pitch:	3.72 mm
Line pitch:	7.81 mm
Dot size:	0.44 x 0.785 mm (X × Y)
Dot pitch:	0.57 x 0.915 mm (X × Y)
Weight:	Approximately 48 g

### 6 Applicable Specifications

Applicable reliability spec:	TT-99-3102
Applicable production spec:	TT-98-3413

### 7 Interface

Parallel Interface: i80 type 8bit bus(C MOS Signal level)  
Serial Interface: Asynchronous(RS232 level)

**The module cannot receive both serial and parallel data at the same time.**

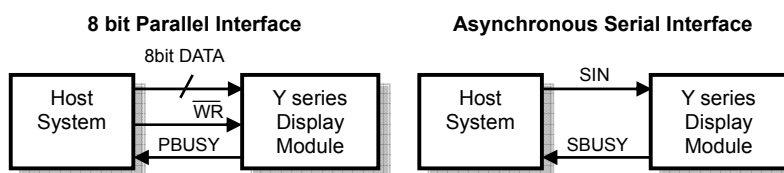

**Monitoring the busy line is strongly recommended, because it prevents data loss and minimizes a waiting time to write next data.**

## 7.1 Parallel Interface

### 7.1.1 Basic Operation

Data (D0-D7) has to be set prior to a rising edge of /WR line, and the data is clocked in on the rising edge of /WR line.

During data execution, the parallel busy line is high (PBUSY=1).

Writing data when PBUSY = 1 causes data loss, so please write data when PBUSY = 0.

### 7.1.2 Flowchart

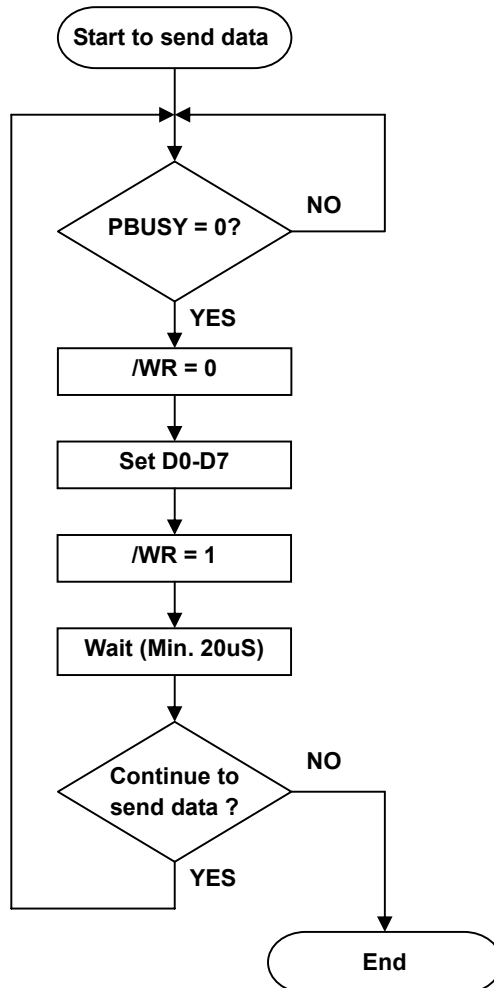



### 7.1.3 Interface Timing

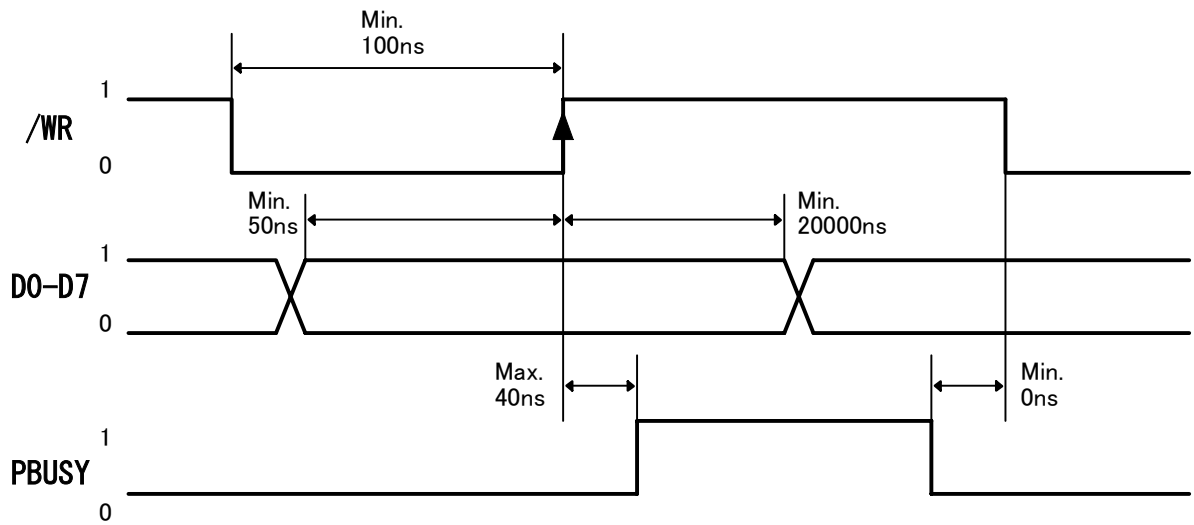

**Note:** Monitoring the parallel busy line (PBUSY) is strongly recommended, because it prevents data loss and minimizes a waiting time to write next data. Please write data when PBUSY = 0.

## 7.2 Serial Interface

### 7.2.1 Basic Operation

**Default setting: Asynchronous Serial Interface (Baud rate = 38,400bps)**

The capacity of the receiving buffer is 64 bytes. The relationship between SBUSY and the receiving buffer is as follows;

	Remaining space of receiving buffer
SBUSY 0 -> 1	16 byte or less
SBUSY 1 -> 0	24 byte or more

Writing data when SBUSY = 1 may cause data loss, so please write data when SBUSY = 0.

### 7.2.2 Flowchart

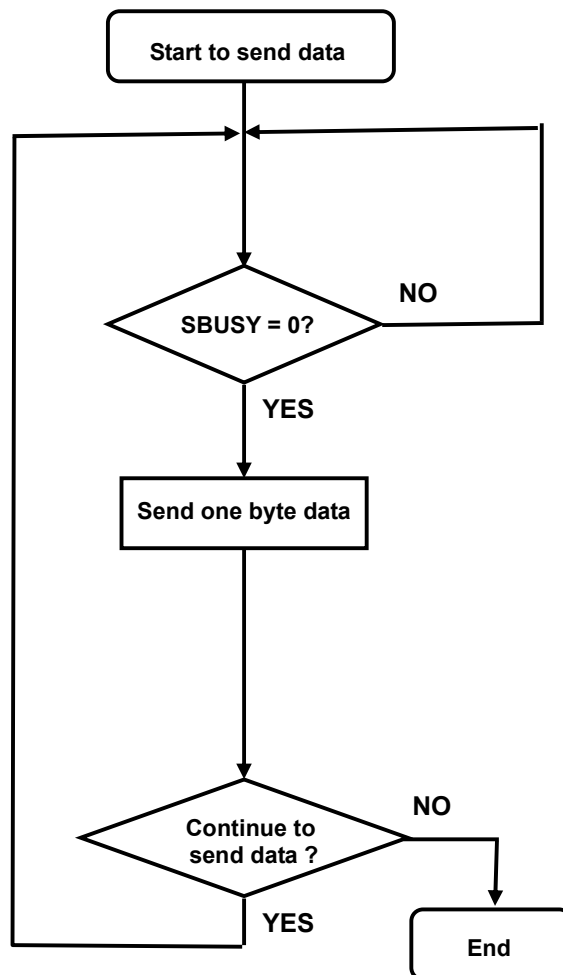

### 7.2.3 Asynchronous Serial Interface Timing

#### 7.2.3.1 Data write

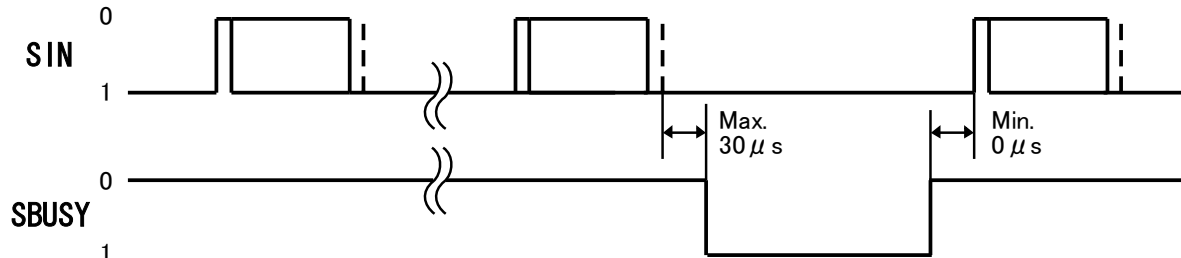

Protocol:

<b>Baud rate</b>	9,600 ~ 115,200bps (Selectable by Jumper) Default: 38,400bps
<b>Parity</b>	None
<b>Format</b>	Start (1bit) + Data (8bit) + Stop (1bit)
<b>Handshake</b>	SBUSY

**Note:** Monitoring the serial busy line (SBUSY) is strongly recommended, because it prevents data loss and minimizes a waiting time to write next data. Please write data when SBUSY = 0.

#### 7.2.3.2 Data read

This is used for Read states information command only.

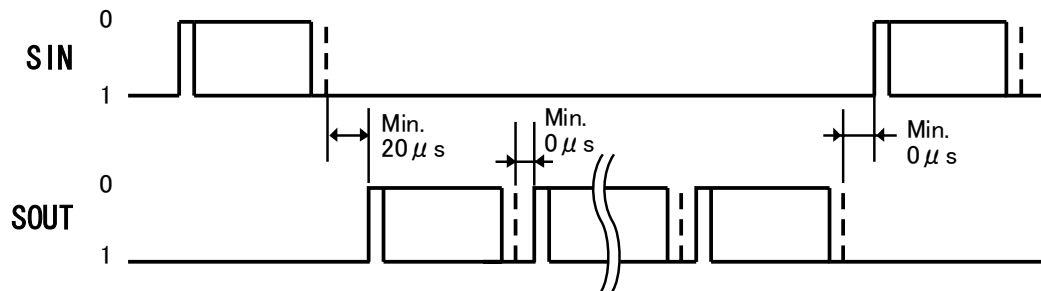

Protocol:

<b>Baud rate</b>	9,600 ~ 115,200bps (Selectable by Jumper) Default: 38,400bps
<b>Parity</b>	None
<b>Format</b>	Start (1bit) + Data (8bit) + Stop (1bit)
<b>Handshake</b>	None

**Note:** Output data is transferred collectively from a VFD module, so a receiving buffer may be required on a host system to prevent data loss.

### 7.3 Reset Timing

Reset pulse (active low) should be longer than 1ms.

The module sets the SBUSY/PBUSY line upon receipt of Reset signal and clears the line when ready to receive data.

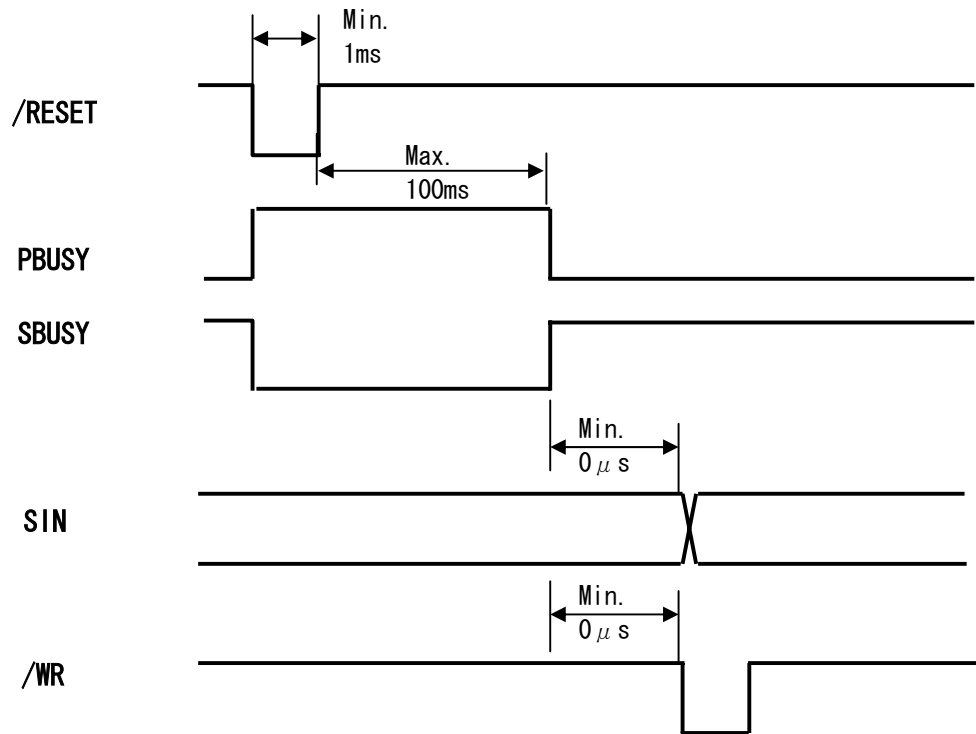

## 8 Jumper Setting

### 8.1 Jumper location

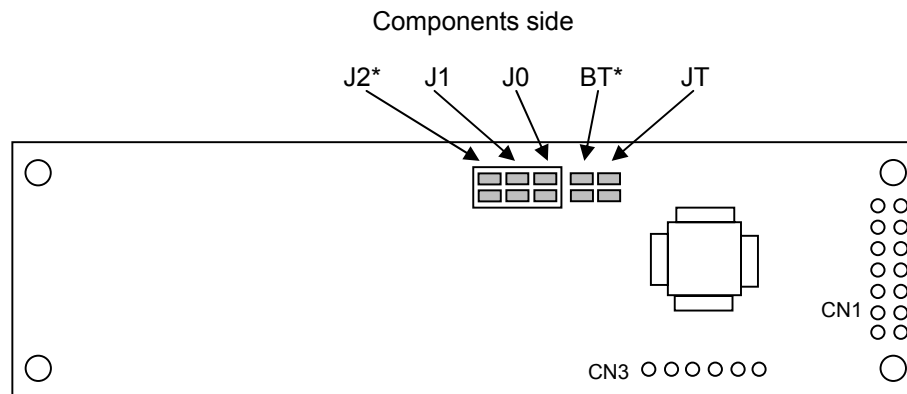

Note: Jumper “J2” and “BT” is for factory use only. **Please do not change.**

#### 8.1.1 Baud Rate Setting (for Asynchronous Serial Interface only)

Baud Rate	J0	J1
38,400bps (Default)	OPEN	OPEN
19,200bps	SHORT	OEPN
9,600bps	OPEN	SHORT
115,200bps	SHORT	SHORT

#### 8.1.2 Test Mode

Refer to “9.4 Test mode”.

Mode	JT
Direct Command Mode (Default)	OPEN
Test Mode	SHORT

## 9 Operating Mode

This module has the following operating modes which are selectable by commands or jumper setting.

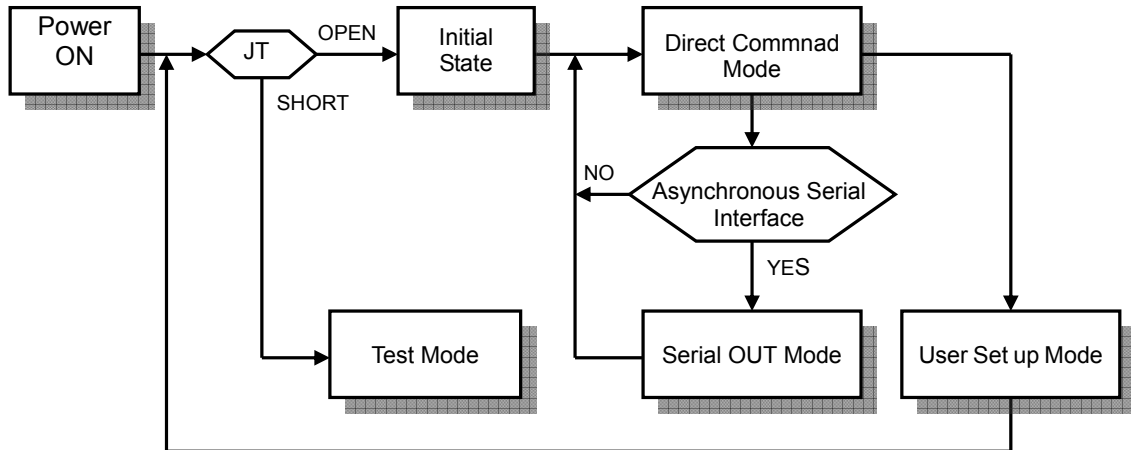

### 9.1 Direct Command Mode

The module accepts data and all commands except “13.3.40 User setup mode end”, “13.3.41 Define FROM user font”, “13.3.42 Read status information”, “13.3.43 Display status information”, and “13.3.45 Serial OUT mode end”.

### 9.2 User Set up Mode

Under this mode, an on-board flash memory is accessible.

The module accepts only three commands: “13.3.40 User set up mode end”, “13.3.41 Define FROM user font” and “13.3.43 Display status information”.

### 9.3 Serial OUT Mode

Under this mode, status information is readable via Asynchronous Serial Interface.

The module accepts only two commands: “13.3.42 Read status information” and “13.3.45 Serial OUT mode end”.

### 9.4 Test mode

The module does not accept any commands but displays test-patterns. Test purpose only.

### 10 Font Table Configuration

This display's Font Table (20h-FFh) is configured as follows. The configuration can be changed by command.

The Font Table used in the default state is as follows.

	2 x H	3 x H	4 x H	5 x H	6 x H	7 x H	8 x H	9 x H	A x H	B x H	C x H	D x H	E x H	F x H	
x0H		0	⓪	P	Ⓟ	p	9	é	á	á	á	á	á	á	ⓧ
x1H	!	1	À	Q	a	q	Ù	æ	i	ⓧ	†	†	†	†	±
x2H	"	2	B	R	b	r	é	á	á	ⓧ	†	†	†	†	±
x3H	ⓧ	3	C	S	c	s	à	ò	ó	†	†	†	†	†	±
x4H	ⓧ	4	D	T	d	t	à	ò	†	†	†	†	†	†	±
x5H	¿	5	E	U	e	u	à	ò	†	†	†	†	†	†	±
x6H	&	6	F	V	f	v	à	ò	†	†	†	†	†	†	±
x7H	'	7	G	U	g	w	é	ó	†	†	†	†	†	†	±
x8H	(	8	H	X	h	x	é	ó	†	†	†	†	†	†	±
x9H	)	9	I	Y	i	y	é	ó	†	†	†	†	†	†	±
xAH	*	:	J	Z	j	z	é	ó	†	†	†	†	†	†	±
xBH	+	:	K	⓪	k	⓪	i	é	†	†	†	†	†	†	±
xCH	,	<	L	⓪	l	⓪	i	é	†	†	†	†	†	†	±
xDH	-	=	M	⓪	m	⓪	i	é	†	†	†	†	†	†	±
xEH	.	>	N	⓪	n	⓪	À	†	†	†	†	†	†	†	±
xFH	/	?	O	⓪	o	⓪	À	†	†	†	†	†	†	†	±

13.3.20 Specify International font set  
1Bh 52h n

13.3.30 Specify character code type  
1Bh 74h n

For font pattern details, refer to font spec. DS-1519-0002-xx.

### 11 Display Area-End of Line Behavior

In most cases, a cursor moves to the next position after a character is displayed on the current cursor position, but some exceptional cases exist. At end of line, the next behavior of a display area depends on the current cursor position, character size and display mode. Display area behaviors for some magnified character sizes are as follows:

#### Regular size (1×1) characters (Over-write mode)

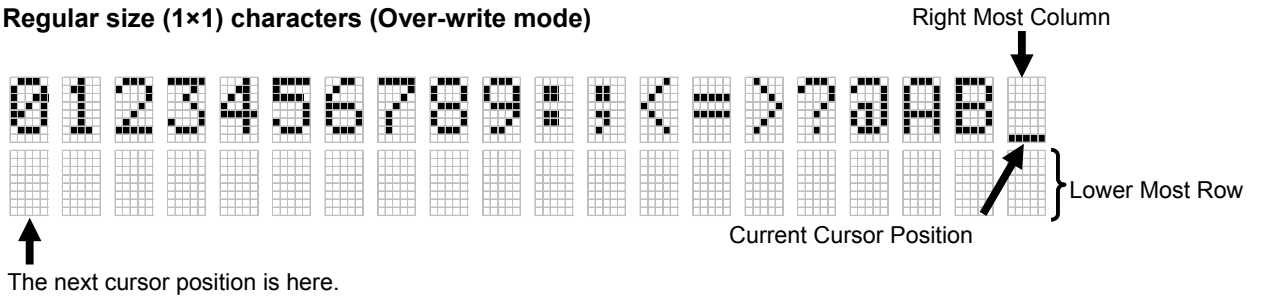

#### 1×2 Magnified characters (Over-write mode)

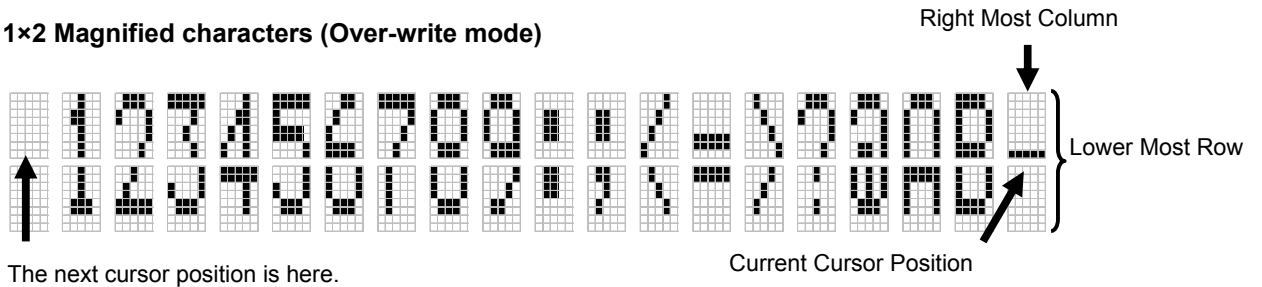

#### 2×2 Magnified characters (Over-write mode)

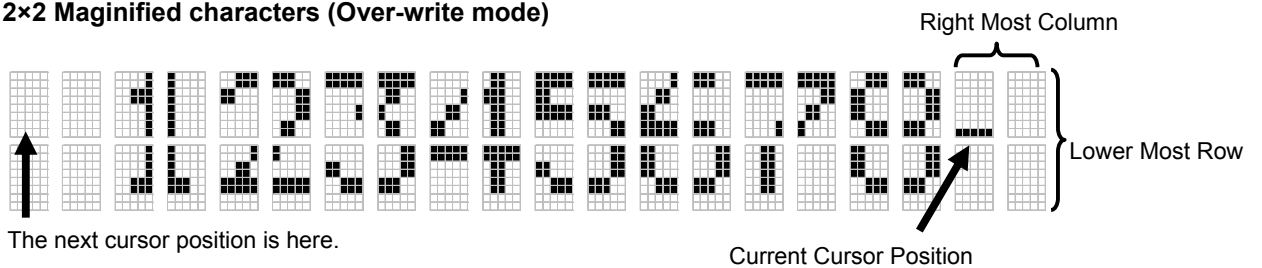

#### 2×2 Magnified characters (Over-write mode)

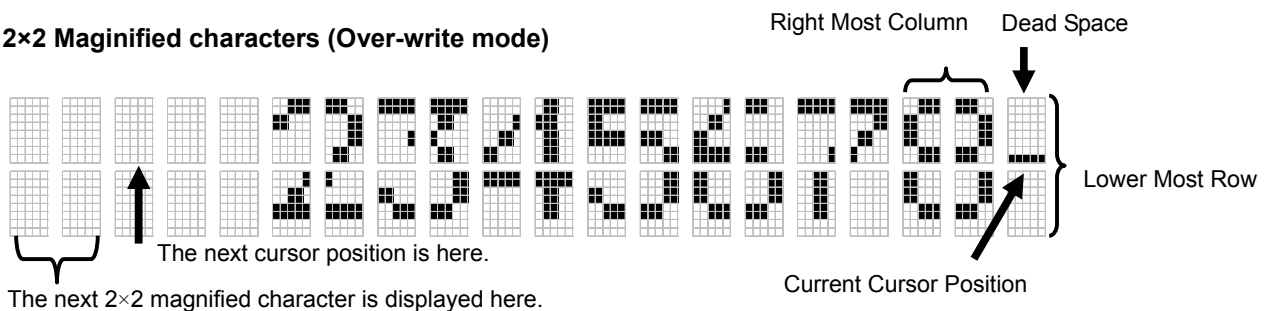

It is possible to display a regular size (1×1) character in the dead space.



## 12 Initial setting

Initial states are set as follows.

	Power on	"Initialize display" command	External reset or "Reset" command	"User set up mode end" command
Cursor position	Home position			
RAM user font	Disable			
Cursor display	Underline cursor			
Display mode	Over-write mode			
Write mode	Quick write mode			
International font set	America			
Character code type	PC437(USA – Euro std)			
Character blink mode	Character blink mode OFF			
Underline display mode	Underline display mode OFF			
Individual Character Brightness Level Setting	Level 8 (100%)			
Brightness level	100%			
Blink speed	40h			
Horizontal scroll speed	Instantaneous (n=00h)			
RAM User font data	Cleared			
Blink display action (at c=00h)	—	Stopped		
Select/Deselect 5×8 Matrix font	5×8 Matrix font			
Select/Deselect Alternative Magnified Font	Normal font			
Font Magnification	x=1, y=1			
Baud rate (J0, J1)	Re-loaded	Not re-loaded	Re-loaded	Re-loaded
Test mode (JT)	Re-loaded	Not re-loaded	Re-loaded	Re-loaded

## 13 Commands

This display's command is configured as following group.

### 13.1 Command Configuration

08H-16H	Control command
1BH ...	ESC command
1FH ...	User Setup command
— 1FH 28H 61H ...	— Action command
— 1FH 28H 65H ...	— Operation mode-related command
— 1FH 28H 67H ...	— Character-related command
20H-FFH	Character code

### 13.2 Command Set

Command Name	Hex Code				
	BYTE1	BYTE2	BYTE3	BYTE4	Parameter
Back Space	08h	—	—	—	—
Horizontal Tab	09h	—	—	—	—
Line Feed	0Ah	—	—	—	—
Home Position	0Bh	—	—	—	—
Display Clear	0Ch	—	—	—	—
Carriage Return	0Dh	—	—	—	—
Underline cursor mode	13h	—	—	—	—
Cursor off mode	14h	—	—	—	—
Block cursor mode	15h	—	—	—	—
Underline cursor blink mode	16h	—	—	—	—
RAM user font	1Bh	25h	—	—	n
Define RAM user font		26h	01h	—	c1 c2 [x1 d1...d(a X x1)]... [xk d1...d(a X xk)]
Delete RAM user font		3Fh	01h	—	c
Initialize display		40h	—	—	—
Character blink mode OFF		41h	—	—	—
Character blink mode ON		42h	—	—	—
Specify quick write mode		45h	—	—	—
Specify International font set		52h	—	—	n
Specify flickerless write mode		53h	—	—	—
Blink speed control		54h	—	—	s
Underline display mode ON		55h	—	—	—
Underline display mode OFF		57h	—	—	—
Insert character		58h	F3h	—	—
Delete character			F4h	—	—
Insert line			F5h	—	—
Delete line			F6h	—	—
Reset			FFh	—	—
Specify character code type		74h	—	—	n
Over-write mode		1Fh	01h	—	—
Vertical scroll mode			02h	—	—
Horizontal scroll mode	03h		—	—	—
Cursor set	24h		—	—	xL 00h yL 00h
Wait	28h		61h	01h	t
Display blink				11h	p t1 t2 c
Screen saver				40h	p
User set up mode start			65h	01h	d1 d2
User set up mode end				02h	d1 d2 d3
Define FROM user font				14h	P(20h-1) P(20h-2)...P(FFh-5)
Read Status information				40h	a [b c d e]
Display Status information			41h	a	
Serial OUT mode start			83h	d1 d2	
Serial OUT mode end			84h	d1 d2 d3	
Select / Deselect 5×8 Matrix font	67h		04h	d	
Select/Deselect Alternative Magnified Font			06h	s	
Font Magnification			40h	x y	
Individual Character Brightness Level Setting	50h		50h	d1 d2 d3	
Brightness level setting			58h	—	n
Horizontal scroll speed	73h		—	—	n
Character display	20-FFh	—	—	—	

### 13.3 Detail of Command Set

#### 13.3.1 Character display

Code: 20h – FFh

Please refer to “11 Display Area-End of Line Behavior” before reading.

Function: Display a character on the current cursor position. The details of operation are as follows:

When “Over-write mode” is selected.

Current cursor position		Operations
X position (Column)	Y position (Row)	
Excluding right most column	-	1. Display a character on the current cursor position. 2. Increment the cursor to the right by one column.
Right most column	Excluding lower most row	1. Display a character on the current cursor position. 2. Move the cursor to left most column of next lower row.
	Lower most row	1. Display a character on the current cursor position. 2. Move the cursor to the home position (left most column of upper most row).

When “Vertical scroll mode” is selected.

Current cursor position		Operations
X position (Column)	Y position (Row)	
Excluding right most column	-	1. Display a character on the current cursor position. 2. Increment the cursor to the right by one column.
Right most column	Excluding lower most row	1. Display a character on the current cursor position. 2. Move the cursor to left most column of next lower row.
	Lower most row	1. Display a character on the current cursor position. 2. Clear upper most row. 3. Shift all rows up by one to make lower most row clear. 4. Move the cursor to left most column of lower most row.

When “Horizontal scroll mode” is selected.

Cursor position		Operations
X direction	Y direction	
Excluding right most column	-	1. Display a character on the current cursor position. 2. Increment the cursor to the right by one column.
Right most column	-	1. Display a character on the current cursor position. 2. Move to Scroll ON mode. Note: The cursor does not move.

	Operations
Scroll ON mode	1. Shift only the current row left by one column to make a space for the next character. 2. Display a character on the space Note: The cursor does not move.

Note: Scroll ON mode is cancelled if any of the following commands are executed: “Back Space”, “Line Feed”, “Home Position”, “Display Clear”, “Carriage Return”, “Cursor Set”, “Over-write mode”, “Vertical scroll mode”, “Horizontal scroll mode”, “Insert character”, “Delete character”, “Insert line” and “Delete line”.

### 13.3.2 Back Space

Code: 08h

Please refer to “11 Display Area-End of Line Behavior” before reading.

Function: The cursor moves to the left by one character. The details of operation are as follows:

When “Over-write mode” or “Vertical scroll mode” is selected.

Current cursor position		Operations
X direction (Column)	Y direction (Row)	
Excluding left most column	-	1. Decrement the cursor to the left by one column.
Left most column	Excluding upper most row	1. Move the cursor to right most column of next upper row.
	Upper most row	No operation

When “Horizontal scroll mode” is selected.

Current cursor position		Operations
X direction (Column)	Y direction (Row)	
Excluding left most column	-	1. Decrement the cursor to the left by one column.
Left most column	-	No operation

### 13.3.3 Horizontal Tab

Code: 09h

Please refer to “11 Display Area-End of Line Behavior” before reading.

Function: The cursor moves to the right by one character. The details of operation are as follows:

When “Over-write mode” is selected.

Current cursor position		Operations
X direction (Column)	Y direction (Row)	
Excluding right most column	-	1. Increment the cursor to the right by one column.
Right most column	Excluding lower most row	1. Move the cursor to left most column of next lower row.
	Lower most row	1. Move the cursor to the home position (left most column of upper most row).

When “Vertical scroll mode” is selected.

Current cursor position		Operations
X direction (Column)	Y direction (Row)	
Excluding right most column	-	1. Increment the cursor to the right by one column.
Right most column	Excluding lower most row	1. Move the cursor to left most column of next lower row.
	Lower most row	1. Clear upper most row. 2. Shift all rows up by one to make lower most row clear. 3. Move the cursor to left most column of lower most row.

When "Horizontal scroll mode" is selected.

Current cursor position		Operations
X direction (Column)	Y direction (Row)	
Excluding right most column	-	1. Increment the cursor to the right by one column.
Right most column	-	1. Shift only the current row left by one column. 2. Keep executing this operation (Scroll ON mode). Note: The cursor does not move.

Note: Scroll ON mode is cancelled if any of the following commands are executed: "Back Space", "Line Feed", "Home Position", "Display Clear", "Carriage Return", "Cursor Set", "Over-write mode", "Vertical scroll mode", "Horizontal scroll mode", "Insert character", "Delete character", "Insert line" and "Delete line".

### 13.3.4 Line Feed

Code: 0Ah

Please refer to "11 Display Area-End of Line Behavior" before reading.

Function: The cursor moves to next lower line. The details of operation are as follows:

When "Over-write mode" is selected.

Current cursor position		Operations
X direction (Column)	Y direction (Row)	
-	Excluding lower most row	1. Move the cursor to the same column of next lower row.
-	Lower most row	1. Move the cursor to the home position (left most column of upper most row).

When "Vertical scroll mode" is selected.

Current cursor position		Operations
X direction (Column)	Y direction (Row)	
-	Excluding lower most row	1. Move the cursor to the same column of next lower row.
-	Lower most row	1. Clear upper most row. 2. Shift all rows up by one to make lower most row clear. Note: The cursor does not move.

When "Horizontal scroll mode" is selected.

Current cursor position		Operations
X direction (Column)	Y direction (Row)	
-	-	No operation

### 13.3.5 Home Position

Code: 0Bh

Function: Cursor moves to the home position. (the left end of top line).

**13.3.6 Display Clear****Code: 0Ch**

Function: Display is cleared and cursor moves to home position.

**13.3.7 Carriage Return****Code: 0Dh**

Function: Cursor moves to left end of same line.

**13.3.8 Underline cursor mode****Code: 13h**

Function: Cursor is displayed as underline.

**13.3.9 Cursor off mode****Code: 14h**

Function: Cursor display is OFF.

**13.3.10 Block cursor mode****Code: 15h**Function: Cursor is displayed as a block, blinking.  
Blinking speed can be varied by "Blink Speed Control" command.**13.3.11 Underline cursor blink mode****Code: 16h**Function: Cursor is displayed as underline, blinking.  
Blinking speed can be varied by "Blink Speed Control" command.**13.3.12 Cursor set****Code: 1Fh 24h xL 00h yL 00h**

xL: Cursor position x Lower byte (1 char /unit)

yL: Cursor position y Lower byte (1 line /unit)

Definable area:  $0 (00h) \leq xL \leq 19 (13h)$   
 $0 (00h) \leq yL \leq 1 (01h)$ 

Function: The cursor moves to the specified X, Y position. If the specified X, Y position (X, Y, either or both) is outside the definable area, the command is ignored, and the cursor remains in the same position.

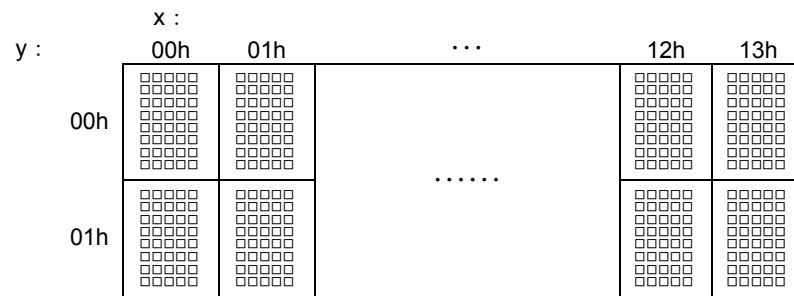

### 13.3.13 Initialize display

**Code:** 1Bh 40h

Function: Clear display and return settings to initial state.  
Software settings return to power-on state.  
Jumper settings are not re-loaded

### 13.3.14 RAM user font

**Code:** 1Bh 25h n

Function: Enable or disable for RAM user font.

n = 01h, 31h: Enable (If RAM user font is not defined for a character code, built-in character is displayed)

n = 00h, 30h: Disable (RAM user font already defined are not affected)

Initial value: n = 00h

Characters already displayed are not affected.

In case of user font enable (n=01h, 31h), RAM user font is used for character codes defined using "Define RAM user font" command regardless of the state of various other settings.

### 13.3.15 Define RAM user font

**Code:** 1Bh 26h a c1 c2 [x1 d1...d(a\*x1)]...[xk d1...d(a\*xk)]

a: Select character type  
 c1: Start character code  
 c2: End character code  
 x: Number of dot for X direction  
 d: Defined data

Definable area: a = 1 (01h)  
 $32 (20h) \leq c1 \leq c2 \leq 255 (FFh)$   
 x = 5 (05h)  
 $0 (00h) \leq d \leq 255 (FFh)$   
 $k = c2 - c1 + 1$

Function: Define user font into RAM.

A maximum of 16 characters may be defined.

After the first 16 are defined, any additional user font characters required must replace one already defined.

To display RAM user font characters, execution of "Define RAM user font" and "RAM user font" command is required. If a RAM user font character that is currently being displayed is re-defined, the currently-displayed character also changes to the new RAM user font character.

< RAM User font data format> 5x8 dot assignment

P1	P2	P3	P4	P5
P6	P7	P8	P9	P10
P11	P12	P13	P14	P15
P16	P17	P18	P19	P20
P21	P22	P23	P24	P25
P26	P27	P28	P29	P30
P31	P32	P33	P34	P35
P36	P37	P38	P39	P40

	B7(MSB)	B6	B5	B4	B3	B2	B1	B0(LSB)
1st byte	P8	P7	P6	P5	P4	P3	P2	P1
2nd byte	P16	P15	P14	P13	P12	P11	P10	P9
3rd byte	P24	P23	P22	P21	P20	P19	P18	P17
4th byte	P32	P31	P30	P29	P28	P27	P26	P25
5th byte	P40	P39	P38	P37	P36	P35	P34	P33



### 13.3.16 Delete RAM user font

**Code:** 1Bh 3Fh a c

a: Select character

c: Character code to delete

Definable area: a = 1 (01h)  
 $32 (20h) \leq c \leq 255 (FFh)$

Function: Delete defined RAM user font character.

The built-in character is displayed after this command is executed.

If the RAM user font character is currently being displayed, the display changes to built-in character (according to the current settings for "Specify international font set" and "Specify character code type" command).

This command is ignored if character code for RAM user font is not defined.

### 13.3.17 Character blink mode OFF

**Code:** 1Bh 41h

Function: Cancel character blink mode.

Blinking stops for characters written after this command is executed.

Characters already displayed are not affected.

### 13.3.18 Character blink mode ON

**Code:** 1Bh 42h

Function: Specifies character blink mode.

Blinking starts for characters written after this command is executed.

Characters already displayed are not affected.

Blinking speed can be varied by "Blink speed control" command.

### 13.3.19 Specify quick write mode

**Code:** 1Bh 45h

Function: Specifies quick write mode.

Quick data write with minimum BUSY time will be provided by this mode because data acceptance is given priority over refreshing of the screen.

Note: Within this mode, continuous high speed data write may cause display to flicker.

Blinking speed may deviate from set speed.

**The figure in 13.3.21 Specify flickerless write mode shows the difference between Flickerless Mode and Quick Write Mode.**

### 13.3.20 Specify International font set

**Code:** 1Bh 52h n

Definable area: 0 (00h) ≤ n ≤ 13 (0Dh)

Default: n = 0 (00h)

Function: Select international font set.

Does not affect characters already displayed.

Note: Refer to 10 Font Table Configuration at page 14.

n	Font set
00h	America
01h	France
02h	Germany
03h	England
04h	Denmark 1
05h	Sweden
06h	Italy
07h	Spain1
08h	Japan
09h	Norway
0Ah	Denmark2
0Bh	Spain2
0Ch	Latin America
0Dh	Korea

### 13.3.21 Specify flickerless write mode

**Code:** 1Bh 53h

Function: Specifies flickerless write mode.

Within flickerless mode, although BUSY might become longer, flicker-less high-speed continuous data write can be achieved since refreshing of screen is given priority over data acceptance.

**Note:** The following figure shows the difference between Flickerless Mode and Quick Write Mode. Refer to 13.3.19 Specify quick write mode.

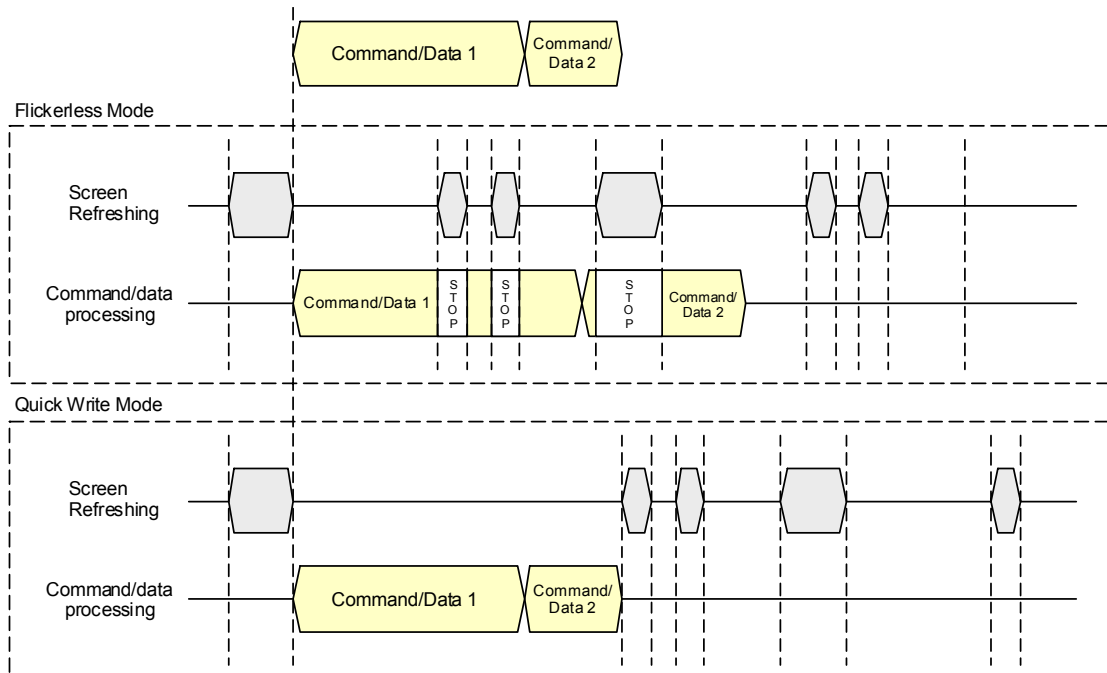

### 13.3.22 Blink speed control

**Code:** 1Bh 54h s

s: Blinking speed

Definable area: 0 (00h)  $\leq$  s  $\leq$  255 (FFh)  
 00h, FFh : 128×13.5ms (Typ.)  
 FEh, FDh : 127×13.5ms (Typ.)  
 ⋮  
 ⋮  
 02h, 01h : 1×13.5ms (Typ.)

Default: s = 40h (32 X 13.5ms)

Function: Specifies blinking speed for block cursor, underline cursor blink, and character blink.



### 13.3.23 Underline display mode ON

**Code:** 1Bh 55h

Function: Specifies underline display mode.

Characters written after this command are displayed with underline. Characters already displayed are not affected.

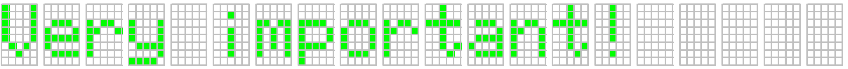
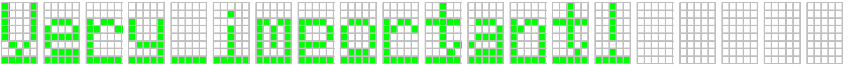
Note: The underline changes an impression of characters on a display. Please refer to the following sample pictures.

5×8 font without underline	
5×8 font with underline	
5×7 font with underline	

### 13.3.24 Underline display mode OFF

**Code:** 1Bh 57h

Function: Cancel underline display mode.

Characters written after this command are displayed with no underline.

Characters already displayed are not affected.

### 13.3.25 Insert character

**Code:** 1Bh 58h F3h

Function: Characters from cursor position to right end of same line move to the right by one character. The right-most character is discarded. One-character blank (space) is set at cursor position. Cursor does not move.

Command is ignored if there is insufficient space in the x and/or y direction for one character at the current cursor position.

**13.3.26 Delete character****Code: 1Bh 58h F4h**

Function: Character at cursor position is deleted, and display from there to right end of same line moves to the left by one character. One-character blank (space) is set at right end of same line. Cursor does not move.

Command is ignored if there is insufficient space in the x and/or y direction for one character at the current cursor position.

**13.3.27 Insert line****Code: 1Bh 58h F5h**

Function: Display contents for the line of the current cursor position, and all lower lines, are shifted down by one line. The line of the current cursor position is blanked (space), and cursor position is set to left end of same line. Display contents in the bottom line are discarded.

Command is ignored if there is insufficient space in the x and/or y direction for one character at the current cursor position.

**13.3.28 Delete line****Code: 1Bh 58h F6h**

Function: The line of the current cursor position is deleted, and the below display is moved up by one line. Cursor position does not change. Bottom line is blanked (space).

Command is ignored if there is insufficient space in the x and/or y direction for one character at the current cursor position.

**13.3.29 Reset****Code: 1Bh 58h FFh**

Function: Transition to state immediately after power-on.

Jumper settings are re-loaded; baud rate (for asynchronous serial), and test mode setting.

**13.3.30 Specify character code type****Code: 1Bh 74h n**

Definable area: n = 0(00h), 1(01h), 2(02h), 3(03h), 4(04h),  
5(05h), 16(10h), 17(11h), 18(12h),  
19(13h), 255(FFh)

Default: n = 0

Function: Selects font code  
Characters already displayed are not affected.

Note: Refer to 10 Font Table Configuration at page 14.

n	Font code type
00h	PC437(USA – Euro std)
01h	Katakana – Japanese
02h	PC850 (Multilingual)
03h	PC860 (Portuguese)
04h	PC863 (Canadian-French)
05h	PC865 (Nordic)
10h	WPC1252
11h	PC866 (Cyrillic #2)
12h	PC852 (Latin 2)
13h	PC858
FFh	FROM User font table

**13.3.31 Over-write mode****Code:** 1Fh 01h

Function: Overwrite or replace an existing character. After replacing the character at right most column of lower most row, move the cursor to the home position.

Note: For further information of this command, please refer to “13.3.1 Character display”, “13.3.2 Back Space”, “13.3.3 Horizontal Tab” and “13.3.4 Line Feed”.

**13.3.32 Vertical scroll mode****Code:** 1Fh 02h

Function: Overwrite or replace an existing character. After replacing the character at right most column of lower most row, shift all rows up by one to make lower most row clear.

Note: For further information of this command, please refer to “13.3.1 Character display”, “13.3.2 Back Space”, “13.3.3 Horizontal Tab” and “13.3.4 Line Feed”.

**13.3.33 Horizontal scroll mode****Code:** 1Fh 03h

Function: Overwrite or replace an existing character. After replacing the character at right most column of any row, shift only the current row left by one column to make a space for the next character.

Note: For further information of this command, please refer to “13.3.1 Character display”, “13.3.2 Back Space”, “13.3.3 Horizontal Tab” and “13.3.4 Line Feed”.

**13.3.34 Horizontal scroll speed****Code:** 1Fh 73h n

Definable area:  $0 (00h) \leq n \leq 31 (1Fh)$

Default:  $n = 0 (00h)$

Note: Next command is not executed until scrolling action is finished.

If n=0 is specified, scrolling is appeared by character n	Speed
00h	Instantaneous
01h – 1Fh	$n \times 13.5ms$ (Typ.)

**13.3.35 Brightness level setting****Code:** 1Fh 58h n

n : Brightness level setting

Definable area:  $1 (01h) \leq n \leq 8 (08h)$ ,  $49 (31h) \leq n \leq 56 (38h)$

Default:  $n = 4 (04h)$

Function: Specify display brightness level.

n	Brightness level
01h or 31h	25 %
02h or 32h	50 %
03h or 33h	75 %
04h or 34h	100 %
05h or 35h	125 %
06h or 36h	150 %
07h or 37h	175 %
08h or 38h	200 %

**13.3.36 Wait****Code:** 1Fh 28h 61h 01h t

t: Wait time

Definable area: 0 (00h)  $\leq$  t  $\leq$  255 (FFh)

Function: Wait for the specified period of time. Command and data processing is suspended.

Wait time = t X approx. 0.5sec

**13.3.37 Display blink****Code:** 1Fh 28h 61h 11h p t1 t2 c

p: Blink pattern

t1: Normal display time

t2: Blank display time

c: Number of repetition

Definable area: 0  $\leq$  p  $\leq$  1

p=0: A display is not affected.

p=1: Repeat blink display with normal and blank display

1 (01h)  $\leq$  t1  $\leq$  255 (FFh)1 (01h)  $\leq$  t2  $\leq$  255 (FFh)0 (00h)  $\leq$  c  $\leq$  255 (FFh)

Function: Blink display action

Blink pattern specified by "p".

Time specified by "t1", "t2", and repeat Blink display

A : t1 X 13.5 ms (Typ.) Normal display

B : t2 X 13.5 ms (Typ.) Blank display

This command does not affect the display memory.

If c=0 is specified, blinking continues during subsequent command/data processing, until c=1 – 255 or Initialize command is specified.

If c=1 – 255 is specified, blink display is repeated 1 – 255 times while command/data execution is stopped. After display blinking is ended, normal display and command/data execution is resumed.

During display blinking, Block cursor, Underline cursor blink and Character blink stops.

After blink action, blinking speed for Block cursor, Underline cursor blink and Character blink change to t1 and t2 as set in blink action command.

**13.3.38 Screen saver****Code: 1Fh 28h 61h 40h p**

p: Screen saver mode

Definable area:  $0 (00h) \leq p \leq 3 (03h), 48 (30h) \leq p \leq 51 (33h)$ 

p=00h or 30h: Power OFF (display OFF, Power save mode)

p=01h or 31h: Power ON (display ON)

p=02h or 32h: All dots OFF

p=03h or 33h: All dots ON

Function: Control power ON or OFF, and start screen saver mode.

p=00h, 01h, 30h, 31h: Control power ON or OFF. This is applied until this command is re-specified

p=02h, 03h, 32h, 33h: Start screen saver mode. When next command or data is inputted, screen saver is cancelled, and previous display condition is resumed.

All dots ON is at gray-shade level 8 (100%), regardless of the setting before Screen saver action.

**13.3.39 User set up mode start****Code: 1Fh 28h 65h 01h 49h 4Eh**

Definable area: d1 = 49h (Character "I")

d2 = 4Eh (Character "N")

Function: Start user set up mode.

**This command is only valid in Direct Command mode.**

Display screen is cleared and normal commands stop being accepted.

**13.3.40 User set up mode end****Code: 1Fh 28h 65h 02h 4Fh 55h 54h**

Definable area: d1 = 4Fh (Character "O")

d2 = 55h (Character "U")

d3 = 54h (Character "T")

Function: End user set up mode, and software reset of display is executed.

**This command is only valid in user setup mode.**

After this command is executed, software reset is executed, the receiving buffer is cleared, and all settings and display are reset to a power-on condition.

Jumper settings are re-loaded; baud rate (for asynchronous serial), and test mode setting.

### 13.3.41 Define FROM user font

**Code:** 1Fh 28h 65h 14h P(20h-1) P(20h-2)...P(FFh-5)

P: Definition data

Definable area:  $0 (00h) \leq P \leq 255 (FFh)$   
 (20h-1)...P(20h-5).....P(FFh-5) 5 Bytes / font x 224 characters (1120 bytes)

Function: Define the 1 byte user font to the user font table in FROM.

All 224 characters should be defined at once; it is not possible to only define some part of the FROM user font address space. Contents of FROM user font table are not defined when shipped.

**This command is only valid in user setup mode.**

Data defined by this command is retained even if power is turned off.

Display power is switched OFF during processing of this command.

The display screen is cleared and display power is turned on again after this command is executed.

To display FROM user font characters, "Specify character code type" command (n=FFh) must be executed.

**Please follow the procedures to define and display FROM user font characters.**

- |   |  |
|---|--|
| (1) "User set up mode start" command      | Code: 1Fh 28h 65h 01h 49h 4Eh                      |
| (2) "Define FROM user font" command       | Code: 1Fh 28h 65h 14h P(20h-1) P(20h-2)...P(FFh-5) |
| (3) "User set up mode end" command        | Code: 1Fh 28h 65h 02h 4Fh 55h 54h                  |
| (4) "Specify character code type" command | Code: 1Bh 74h FFh                                  |

<FROM User font data format> 5x8 dot assignment

P1	P2	P3	P4	P5
P6	P7	P8	P9	P10
P11	P12	P13	P14	P15
P16	P17	P18	P19	P20
P21	P22	P23	P24	P25
P26	P27	P28	P29	P30
P31	P32	P33	P34	P35
P36	P37	P38	P39	P40

	B7(MSB)	B6	B5	B4	B3	B2	B1	B0(LSB)
P(XXh-1)	P8	P7	P6	P5	P4	P3	P2	P1
P(XXh-2)	P16	P15	P14	P13	P12	P11	P10	P9
P(XXh-3)	P24	P23	P22	P21	P20	P19	P18	P17
P(XXh-4)	P32	P31	P30	P29	P28	P27	P26	P25
P(XXh-5)	P40	P39	P38	P37	P36	P35	P34	P33



### 13.3.42 Read Status information

**Code:** 1Fh 28h 65h 40h a [ b c d e ]

Definable area: a =2 (02h), 32 (20h), 48 (30h), 128 (80h)  
 a= 02h : Firmware version information (b, c, d, e are not used)  
 a= 20h : Memory checksum information  
 $0000h \leq ( b + c \times 100h ) \leq FFFFh$  : Start address  
 $0000h \leq ( d + e \times 100h ) \leq FFFFh$  : Data length  
 a= 30h : Product type information (b, c, d, e are not used)  
 a= 80h : User font information (c, d, e are not used)  
 $20h \leq b \leq FFh$  : Character code

Function: Respond with the requested display status information.  
 The following data are sent from Asynchronous serial interface  
**This command is only valid in Serial OUT mode.**

Send data	Hex	Number of data
1: Header	28h	1byte
2: Identifier 1	65h	1byte
3: Identifier 2	40h	1byte
4: Data	00h~FFh	a = 02h : 4 bytes a = 20h : 4 bytes a = 30h : 11 bytes a = 80h : 5 bytes

### 13.3.43 Display Status information

**Code:** 1Fh 28h 65h 41h a

Definable area: a =2 (02h), 32 (20h), 33 (21h)  
 a= 02h : Firmware version  
 a= 20h : Firmware checksum  
 a= 30h : User font table checksum  
 [P(20h-1)...P(FFh-5)]

Function: Display on home position the requested status information.  
**This command is only valid in user setup mode.**

### 13.3.44 Serial OUT mode start

**Code:** 1Fh 28h 65h 83h d1 d2

Definable area: d1 = 49h (Character "I")  
 d2 = 4Eh (Character "N")

Function: Switch SBUSY to Serial OUT and start "Serial OUT mode".  
**This command is only valid when Asynchronous serial interface is selected and mode is Direct Command mode.**

Display screen is cleared and normal commands stop being accepted.  
 Wait at least 5ms after sending 4Eh ("N") before sending next data.  
 During Serial OUT mode, do not use SBUSY for communication flow control.

### 13.3.45 Serial OUT mode end

**Code:** 1Fh 28h 65h 84h d1 d2 d3

Definable area: d1 = 4Fh (Character "O")  
 d2 = 55h (Character "U")  
 d3 = 54h (Character "T")

Function: Switch Serial OUT to SBUSY and start "Direct Command mode".

**This command is only valid in Serial OUT mode.**

After "Serial OUT mode end" command is executed, SBUSY=0 (READY) until receipt of next data.

Wait at least 5ms after sending 54h ("T") before sending next data.

### 13.3.46 Select / Deselect 5×8 Matrix font

**Code:** 1Fh 28h 67h 04h d

d: Select / Deselect 5×8 Matrix font

Definable area:  $128 (80h) \leq d \leq 129 (81h)$   
 d = 80h : Deselect 5×8 Matrix font  
 d = 81h : Select 5×8 Matrix font

Default: d = 81h (Select 5×8 Matrix font)

Function: Select / Deselect 5×8 Matrix font

**Selecting 5×8 Matrix font gives descender to only these five characters: 'g' (67h), 'j' (6Ah), 'p' (70h), 'q' (71h) and 'y' (79h).**

**Both 5×8 font and 5×7 font give the same style fonts to the other characters.**

d=81h: The five characters are displayed in 5×8 font after this command.

Characters already displayed are not affected.

For details of each pattern, refer to font spec. DS-1519-0002-xx.

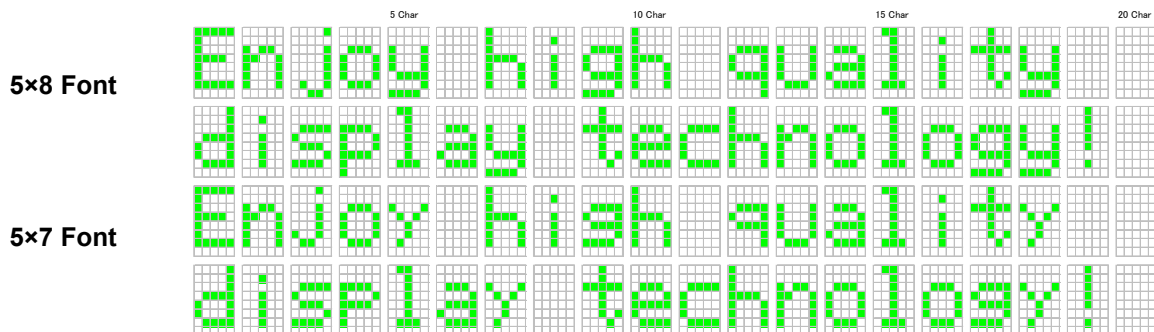

### 13.3.47 Select/Deselect Alternative Magnified Font

**Code:** 1Fh 28h 67h 06h s

s: Select/Deselect Alternative Magnified Font

Definable area: 0 (00h) ≤ s ≤ 1 (01h)

s = 00h : Normal font

s = 01h : Alternative Magnified font

Default: s = 00h

Function: Select Alternative Magnified font to improve legibility for Font magnified display.

This command is valid for characters written after this command execution; it does not affect characters that are already displayed.

Alternative Magnified font is only used when magnification is x=2X, y=2X. At all other times, normal font is used regardless of this setting.

Applicable characters are only for International font set "America" (n=00h). For all other fonts, normal font is used regardless of this setting.

When FROM user font table ("Specify character code type" command) is selected, user font characters have priority, regardless of this setting.

Note: Refer to the DS-1519-0002-xx CU-Y Series VFD character fonts specification.

In case of character "1"

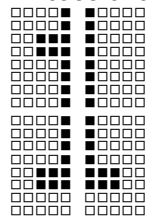

Normal font

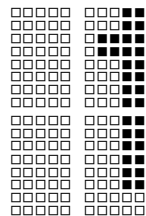

Alternative Magnified font

### 13.3.48 Font Magnification

**Code:** 1Fh 28h 67h 40h x y

x: Specify the size of magnification X

y: Specify the size of magnification Y

Definable area:  $1 (01h) \leq x \leq 2 (02h)$

$1 (01h) \leq y \leq 2 (02h)$

Default: x = 01h

y = 01h

Function: Magnify the character by x times on the right, y times downward.

This command is valid for characters written after this command execution; it does not affect characters that are already displayed.

x=2, y=1 is not supported (command will be ignored).

1x1 magnification  
(default)

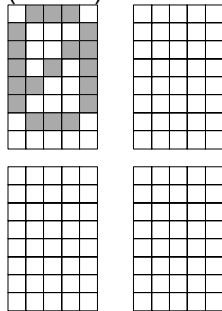

1x2 magnification

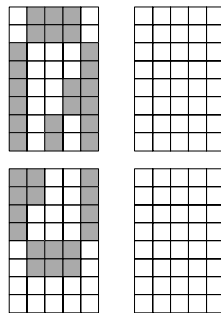

2x2 magnification

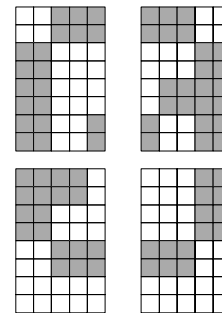

### 13.3.49 Individual Character Brightness Level Setting

**Code:** 1Fh 28h 67h 50h d1 d2 d3

d1: Gray-shade level

d2: Dummy data

d3: Dummy data

Definable area: 1 (01h) ≤ d1 ≤ 8 (08h), 49 (31h) ≤ d1 ≤ 54 (38h)

D1	Level
01h or 31h	Level 1 (0%)
02h or 32h	Level 2 (14%)
03h or 33h	Level 3 (29%)
04h or 34h	Level 4 (43%)
05h or 35h	Level 5 (57%)
06h or 36h	Level 6 (71%)
07h or 37h	Level 7 (86%)
08h or 38h	Level 8 (100%)

0 (00h) ≤ d2 ≤ 255 (FFh)

0 (00h) ≤ d3 ≤ 255 (FFh)

Default: d1 = 8 (08h)

Function: Specify gray-shade level of characters.

This command is valid for characters written after this command execution; it does not affect characters that are already displayed.

Note: This individual character brightness is a relative value of all over display brightness. If the display brightness level and the individual matrix brightness level are 200% (2,000 cd/m<sup>2</sup>) and Level 5 (57%) respectively, the individual character brightness is 2,000 cd/m<sup>2</sup> × 57% = 1,140 cd/m<sup>2</sup>. In order to set all over the display brightness, please refer to the command "13.3.35 Brightness level setting".

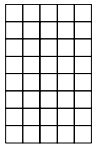
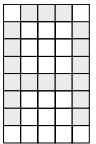
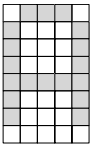
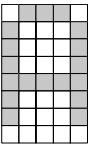
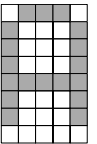
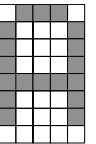
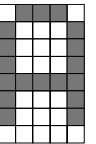
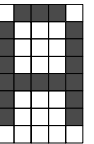
Level 1 (0%)	Level 2 (14%)	Level 3 (29%)	Level 4 (43%)	Level 5 (57%)	Level 6 (71%)	Level 7 (86%)	Level 8 (100%)
							

## 14 Pin Configuration

### 14.1 Parallel interface connector (Fourteen through-holes / CN1)

Pin No.	Signal name	Function	Direction	Pin No.	Signal name	Function	Direction
1	GND	Ground	-	8	D1	Data input	Input
2	VCC	Power supply	-	9	D2	Data input	Input
3	PBUSY	Display busy	Output	10	D3	Data input	Input
4	/RESET	Reset	Input	11	D4	Data input	Input
5	/WR	Data write	Input	12	D5	Data input	Input
6	NC	Non connection	-	13	D6	Data input	Input
7	D0	Data input (LSB)	Input	14	D7	Data input (MSB)	Input

### 14.2 Serial interface connector (Six through-holes / CN3)

Pin No.	Signal name	Function	Direction
1	VCC	Power supply	-
2	SIN	Data receive	Input
3	GND	Ground	-
4	SBUSY	Display busy	Output
5	NC	Non connection	-
6	/RESET	Reset	Input

## 15 Firmware Version Notation

The firmware version is shown in the following position.

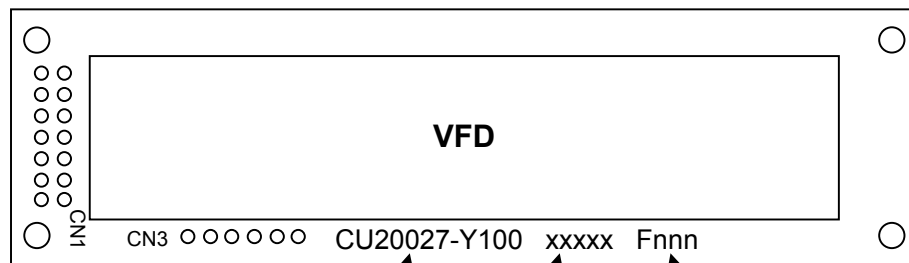

Part Number    Date Code    Firmware Version

16 Physical Dimensions

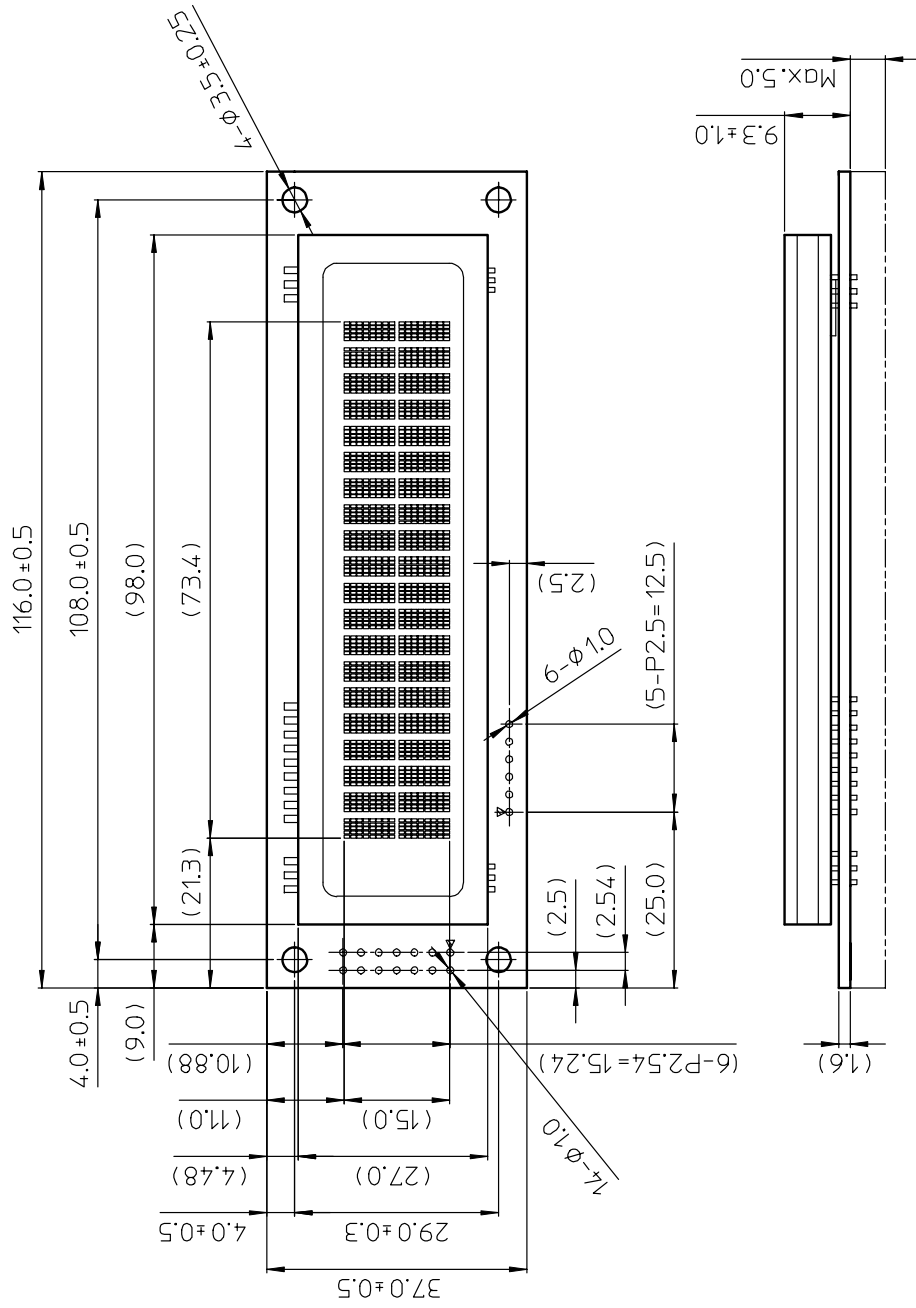

( ) : Reference only  
Unit : mm

## Notice for the Cautious Handling VFD Modules

### Handling and Usage Precautions:

Please carefully follow the appropriate product application notes for proper usage, safety handling, and operation standards for maximum performance.

#### [VFD tubes are made of glass]

- Because the edges of the VFD glass-envelop are not smooth, it is necessary to handle carefully to avoid injuries to your hands
- Please avoid breaking the VFD glass-envelop to prevent injury from sharp glass particles.
- The tip of the exhaust pipe is fragile so avoid shock from impact.
- It is recommended to allow sufficient open space surrounding the exhaust pipe to avoid possible damage.
- Please design the PCB for the VFD-module within 0.3 mm warping tolerance to avoid any forces that may damage the display due to PCB distortion causing a breakdown of the electrical circuit leading to VFD failure.

#### [High voltage]

- Avoid touching conductive electrical parts, because the VFD-module uses high voltage exceeding 30~100 volts.
- Even when electric power is turned off, it may take more than one minute for the electrical current to discharge.

#### [Cable connection]

- Do not unplug the power and/or data cables of VFD-modules during operating condition because unrecoverable damage may result.
- Sending input signals to the VFD-module during a power off condition sometimes causes I/O port damage.
- It is recommended to use a 30 cm or shorter signal cable to prevent functional failures.

#### [Electrostatic charge]

- VFD-modules needs electrostatic free packaging and protection from electrostatic charges during handling and usage.

#### [Structure]

- During operation, VFD and VFD-modules generate heat. Please consider sufficient heat radiation dissipation using heat sink solutions.
- We prefer to use UL grade materials or components in conjunction with VFD-modules.
- Wrap and twist motion causes stress and may break VFDs & VFD modules. Please adhere to allowances within 0.3mm at the point of attachment.

#### [Power]

- Apply regulated power to the VFD-module within specified voltages to protect from failures.
- Because some VFD-modules may consume in rush current equal to twice the typical current at power-on timing, we recommend using a sufficient power capability and quick starting of the power regulator.
- VFD-module needs a specified voltage at the point of connection. Please use an adequate power cable to avoid a decrease in voltage. We also recommend inserting a power fuse for extra protection.

#### [Operating consideration]

- Illuminating phosphor will decrease in brightness during extended operation. If a fixed pattern illuminates for an extended period,( several hours), the phosphor efficiency will decrease compared to the non operating phosphor causing a non uniform brightness among pixels. Please consider programming the display patterns to use all phosphor segments evenly. Scrolling may be a consideration for a period of time to refresh the phosphor condition and improve even illumination to the pixels.
- We recommend using a signal cable 30cm or less to avoid some possible disturbances to the signal.

#### [Storage and operating environment]

- Please use VFD-modules under the recommended specified environmental conditions. Salty, sulfur and dusty environments may damage the VFD-module even during storage.

#### [Discard]

- Some VFDs contain a small amount of cadmium in the phosphor and lead in the solder. When discarding VFDs or VFD-modules, please adhere to governmental related laws or regulations.

#### [Others]

- Although the VFD-module is designed to be protected from electrical noise, please plan your circuitry to exclude as much noise as possible.
- Do not reconstruct or repair the VFD-module without our authorization. We cannot assure the quality or reliability of unauthorized reconstructed VFD-modules.

### Notice:

- We do not authorize the use of any patents that may be inherent in these specifications.
- Neither whole nor partial copying of these specifications are permitted without our approval.  
If necessary , please ask for assistance from our sales consultant.
- This product is not designed for military, aerospace, medical or other life-critical applications. If you choose to use this product for these applications, please ask us for prior consultation or we cannot take responsibility for problems that may occur.



**Revision Note**

SPEC number	Date	Revision
DS-1571-0001-00	Jan.29, 2009	Initial Issue