

THIS IS A CONTROLLED DOCUMENT.

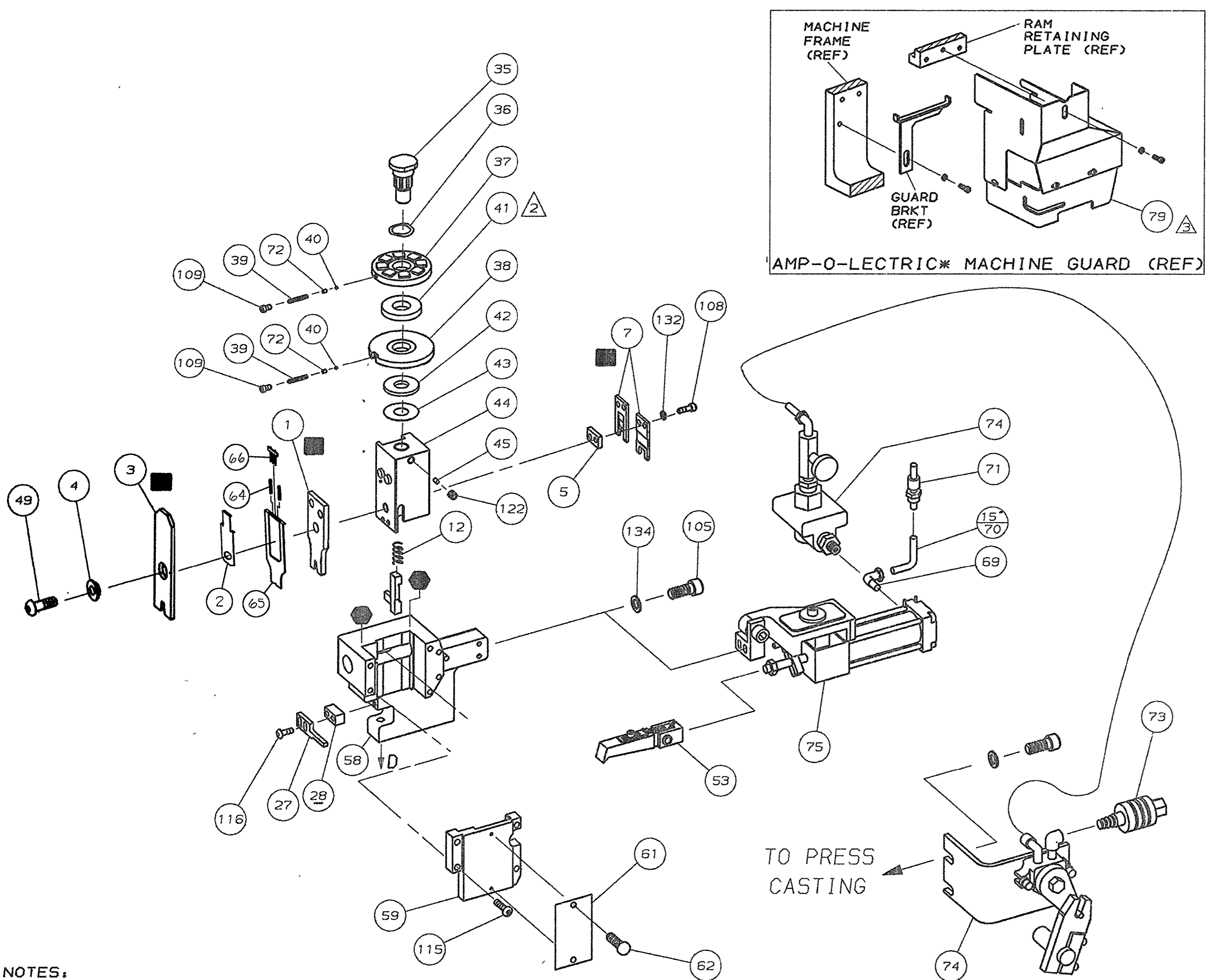

- NOTES:**
1. ONLY THE ITEMS WITH QUANTITIES SPECIFIED ON PARTS LIST ARE USED ON THIS APPLICATOR.
 - 2 USED IN PLACE OF ITEM 38 WHEN INSULATION CRIMP IS NOT USED.
 - 3 GUARD MUST BE IN PLACE WHEN OPERATING APPLICATOR IN AMP-O-LECTRIC MACHINE.
 - 4 QUANTITY IN INCHES.
 - 5 SEE DWGS FOR COMPONENTS.

- KEY:**
- RECOMMENDED SPARE PARTS.
 - GREASE LIGHTLY.

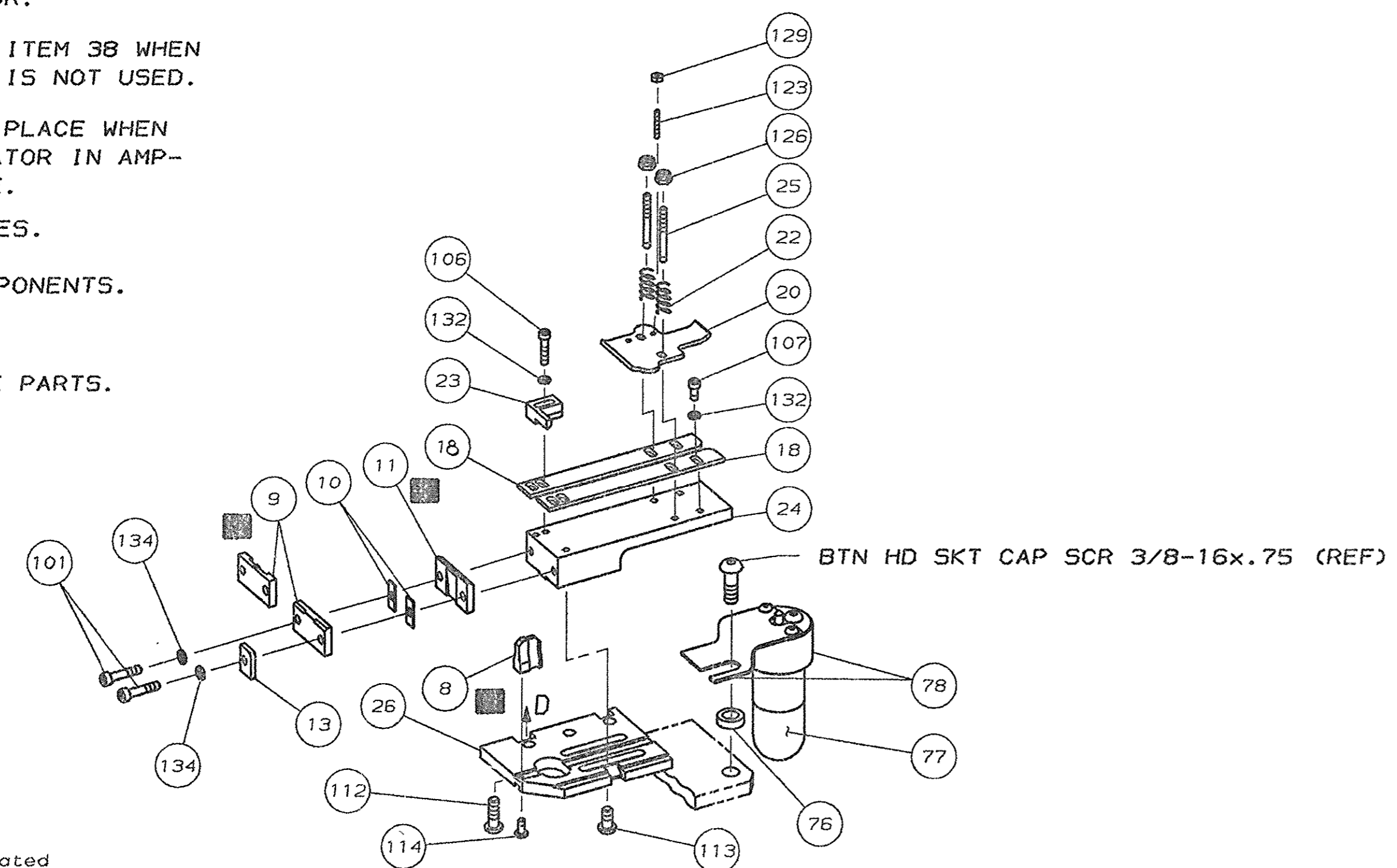

QTY	PART NO	DESCRIPTION	ITEM NO
			145
			144
			143
			142
			141
			140
			139
			138
			137
			136
			135
			134
			133
			132
			131
			130
			129
			128
			127
			126
			125
			124
			123
			122
			121
			120
			119
			118
			117
			116
			115
			114
			113
			112
			111
			110
			109
			108
			107
			106
			105
			104
			103
			102
			101
			79
			78
			77
			76
			75
			74
			73
			72
			71
			70
			69
			68
			67
			66
			65
			64
			63
			62
			61
			60
			59
			58
			57
			56
			55
			54
			53
			52
			51
			50
			49
			48
			47
			46
			45
			44
			43
			42
			41
			40
			39
			38
			37
			36
			35
			34
			33
			32
			31
			30
			29
			28
			27
			26
			25
			24
			23
			22
			21
			20
			19
			18
			17
			16
			15
			14
			13
			12
			11
			10
			9
			8
			7
			6
			5
			4
			3
			2
			1

QTY	PART NO	DESCRIPTION	ITEM NO
			64
			63
			62
			61
			60
			59
			58
			57
			56
			55
			54
			53
			52
			51
			50
			49
			48
			47
			46
			45
			44
			43
			42
			41
			40
			39
			38
			37
			36
			35
			34
			33
			32
			31
			30
			29
			28
			27
			26
			25
			24
			23
			22
			21
			20
			19
			18
			17
			16
			15
			14
			13
			12
			11
			10
			9
			8
			7
			6
			5
			4
			3
			2
			1

REMARKS	NO	REV
TO APPLY TERMINAL		
APPL USED ON MACHINE PART NO	MACH SERIAL NO	DISTRIBUTION
CUSTOMER NAME	APPL SERIAL NO	ORIGINAL
ADDRESS	PURCHASE ORDER	CUSTOMER COPY
CITY	ENG APP	FIELD ENG COPY

CRIMPING DATA				APPLICATOR WILL APPLY
PAD LTR	CRIMP HEIGHT	WIRE SIZE	WIRE STRIP LENGTH	925688
A	.060	1.0 mm ² (17)		
B	.063	.75 mm ² (18)		
C	NOT USED			
D	NOT USED			
CRIMP	SIZE	TYPE	FEED	APPL INST
WIRE	.110	F	.760	A1 8040
INSUL	.300	F		
WIRE RANGE	75-1.0 mm ²	INSULATION RANGE	7mm (275 Dia)	MACHINE NO
REMARKS				565435-5
AMP-O-LECTRIC AIR FEED				
CUSTOMER WIRE REQUIRED FOR APPLICATOR SET-UP & QUALIFICATION				

REV	DATE	DESCRIPTION	BY	CHKD	APP'D
F	0150-1134-01				
E	0150-9329-99				
D	0150-7328-96				
C	REACT. 0150-7103-96				
B	ORIS. 0150-6782-96				
A	ECN R 7330				
G	0150-1227-01				

* Trademark of AMP Incorporated