

REVISIONS					
REV	ECO	DESCRIPTION	DATE	BY	APPR
B1	-	RELEASED DRAWING	JAN-18-2014	ARROW	TOMMY
B2	-	Update drawing	Jun-21-18	Flan	Tommy

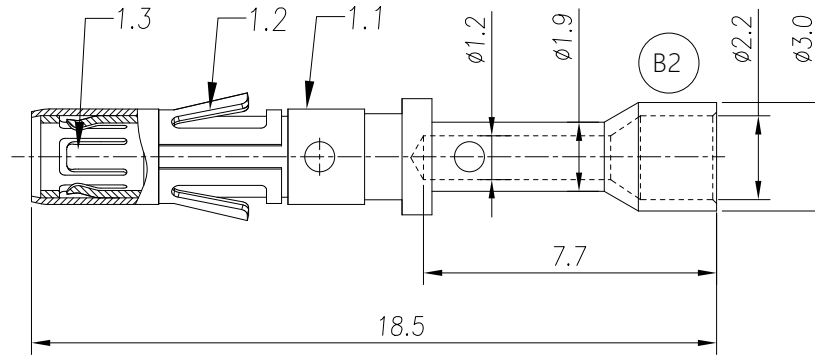

- NOTES: (UNLESS OTHERWISE SPECIFIED)
- MATERIAL:
 - CONTACT BODY: COPPER ALLOY.
 - POSITIONING CLIP: COPPER ALLOY.
 - CROWN CONTACT: COPPER ALLOY.
 - SPECIFICATIONS:
 - CURRENT RATING: 13A(MAX).
 - TERMINATION TYPE: CRIMPING.
 - WIRE RANGE: 22~20AWG.
 - SUITABLE SOCKET TYPE: MP20M23xx.
 - RoHS COMPLIANT.
 - ALL DIMENSIONS ARE FOR REFERENCE USE ONLY.

P/N	CONTACT PLATING(MATING AREA)
MS20M23T	TIN PLATING OVER NICKEL.
MS20M23S	SILVER PLATING OVER NICKEL.
MS20M23F	GOLD FLASH PLATING OVER NICKEL.
MS20M23G5	5 μ "GOLD PLATING OVER NICKEL.
MS20M23G10	10 μ "GOLD PLATING OVER NICKEL.
MS20M23G15	15 μ "GOLD PLATING OVER NICKEL.
MS20M23G30	30 μ "GOLD PLATING OVER NICKEL.

QUANTITY	PART NUMBER	DESCRIPTION	ITEM
MATERIALS LIST			
<small>UNLESS OTHERWISE SPECIFIED</small> 1) All dimensions are in metric(mm). 2) Tolerances are as follows: 1 PL DEC ± 0.30 2 PL DEC ± 0.15 3 PL DEC ± 0.08 3) Note reference =		SIGNATURES DRAWN: Flan CHECKED: Tod ENGINEER: APPROVAL: Tommy DATE: Jun-21-18	Amphenol Sine Systems - www.amphenol-sine.com 44724 Morley Drive Clinton Township, MI 48036
<small>MATERIAL SPECIFICATIONS:</small> PROCESS SPECIFICATIONS: NEXT ASSY:		<small>CUSTOMER:</small> THIS DRAWING IS SUPPLIED FOR INFORMATION ONLY. DESIGN FEATURES, SPECIFICATIONS AND PERFORMANCE DATA SHOWN HEREON ARE THE PROPERTY OF THE AMPHENOL CORPORATION. NO RIGHTS OF REPRODUCTION ARE IMPLIED. ALL DIMENSIONS ARE SUBJECT TO NORMAL MANUFACTURING VARIATIONS.	<small>ECO-MATE, SOCKET CONTACT MACHINE, 22-20AWG, SIZE 16</small> SIZE: B TYPE: C- DWG NO: MS20M23xx REVISION: B2 SCALE: NONE SHEET 1 OF 1

TITLE: ECO-MATE SOCKET CONTACT MACHINE, 22-20AWG, SIZE 16
 DWG NO: MS20M23xx
 REV: B2
 SH: 1
 OF: 1