

# Customer Information Sheet

DRAWING No.: Z2170-00 TO Z2177-00, Z2179-00

IF IN DOUBT - ASK

©

NOT TO SCALE

THIRD ANGLE PROJECTION

ALL DIMENSIONS IN mm

Z10002-00  
TOP TOOL

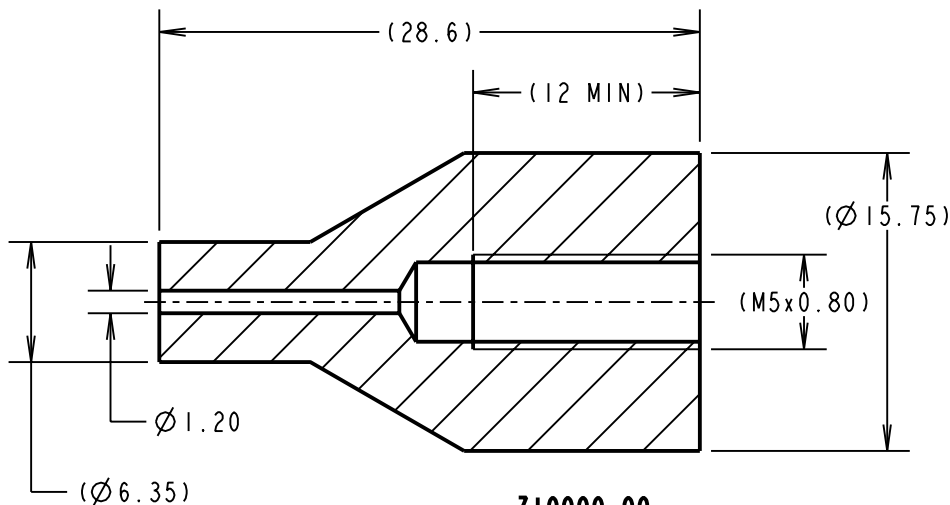
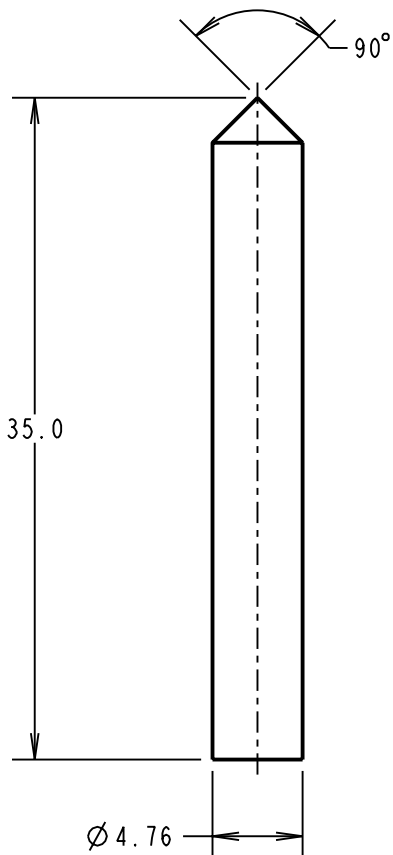

Z10000-00  
BOTTOM TOOL PART  
MACHINED BLANK

Z10002-00  
(TOP TOOL)

SEE TABLE

PCB

Z10000-00  
(BOTTOM TOOL)

OPERATION DIAGRAM

FOR USE WITH THESE PART NUMBERS:

H2170-01	H2170-05	H2171-01	H2171-05	H2172-01	H2172-05
H2173-01	H2173-05	H2174-01	H2174-05	H2175-01	H2175-05
H2176-01	H2176-05	H2177-05	H2179-01	H2179-05	

NOTES:

- MUST BE USED WITH A BENCH PRESS OR OTHER FIXED TOOLING, TO ENSURE EVEN PRESSURE IS APPLIED TO THE HEAD OF THE TERMINAL.
- TOP AND BOTTOM TOOLS ARE PACKED IN A BAG AS A KIT.

SB	2	19.04.11	11243
NAME	ISS.	DATE	C/NOTE
APPROVED:		S.BENNETT	
CHECKED:		S.FLOWER	
DRAWN:		MARK G PLESTED	
CUSTOMER REF.:			
ASSEMBLY DRG:			

**HARWIN**

HARWIN USA  
TEL: 603 893 5376  
FAX: 603 893 5396  
mis@harwin.com

HARWIN Europe (UK)  
TEL: 023 9231 4545  
FAX: 023 9231 4590  
mis@harwin.co.uk

HARWIN Asia  
TEL: +65 6 779 4909  
FAX: +65 6 779 3868  
mis@harwin.com.sg

THIS DRAWING AND ANY INFORMATION OR DESCRIPTIVE MATTER SET OUT HEREON ARE CONFIDENTIAL AND COPYRIGHT PROPERTY OF THE HARWIN GROUP AND MUST NOT BE DISCLOSED, LOANED, COPIED OR USED FOR MANUFACTURING, TENDERING OR FOR ANY OTHER PURPOSE WITHOUT THEIR WRITTEN PERMISSION.

TOLERANCES

X. = ±1mm  
X.X = ±0.25mm  
X.XX = ±0.10mm  
X.XXX = ±0.01mm

ANGLES = ±5°

UNLESS STATED

MATERIAL:

SILVER STEEL

FINISH: CLEAN

S/AREA:

mm<sup>2</sup>

TITLE:

TOP AND BOTTOM TOOL SET

DRAWING NUMBER: Z2170-00 TO Z2177-00, Z2179-00

SHT  
2 OF 2