

PART NO.	ENG. NO.	DIM. "D" DIA.	INSULATION CRIMP PER
02-09-8103	1973-A(P901)	.091±.003/(2.31±0.08)	SECTION "A-A"-1
02-09-8104	1973-A(P901)L		
02-09-8107	1973-1A(105)	.094±.003/(2.39±0.08)	SECTION "A-A"-1
02-09-8108	1973-2A(P901)		
02-09-8109	1973-2A(P901)L	.091±.003/(2.31±0.08)	SECTION "A-A"-2
	-		
	-		
	-		

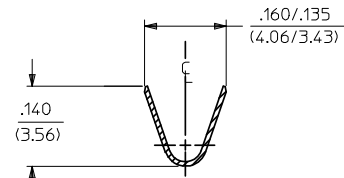
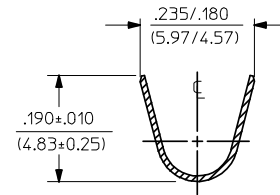
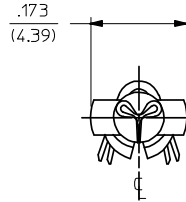

**SECTION "A-A"-2**  
SPECIAL DOUBLE WIRE  
CRIMP FOR 1973-2 VERSION

**SECTION "A-A"-1**  
STANDARD VERSION FOR  
1973 & 1973-1 VERSIONS

**LEGEND**

1973-\*A(\*\*\*\*)\*

VERSION: BLANK=ORIGINAL, 1=MODIFIED PIN DIA., 2=LARGER INSUL. CRIMP

FORM: BLANK=CHAIN, L=LOOSE

P=PREPLATE, BLANK=POSTPLATE

FINISH CODE

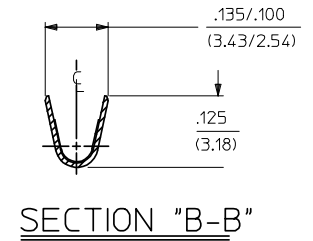
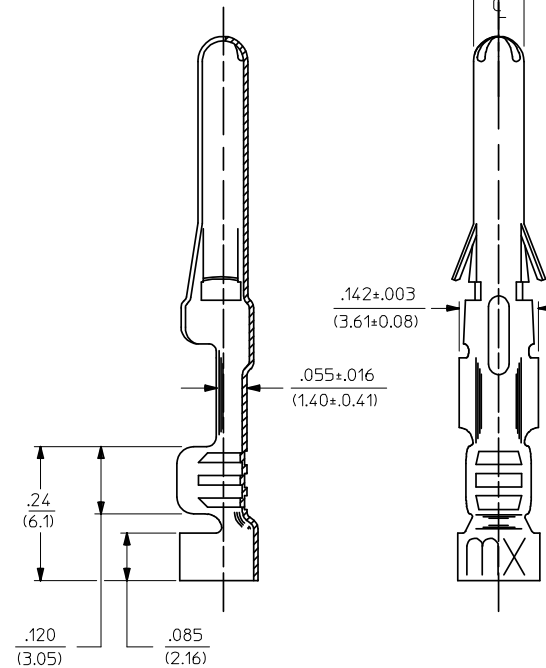
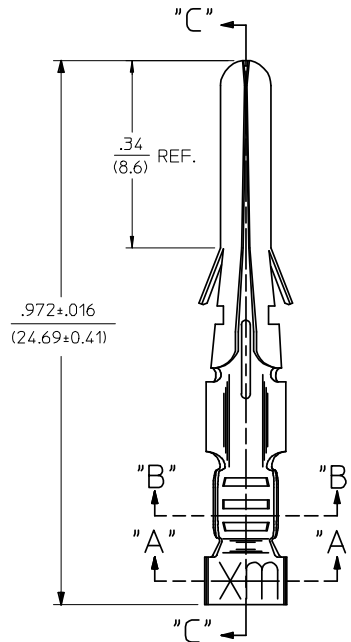

**SECTION "C-C"**

**NOTES:**

- MATERIAL: CARTRIDGR BRASS ALLOY, .010/(0.25) THICK.
- FINISHES:  
105 TIN PLATE .000300/(0.00762) MIN. OVER .000100/(0.00254) MIN. COPPER OVERALL.  
901 HOT TIN DIP .000020/(0.00051) MIN.  
\* THE PRIMARY SHIPPING CARTON WILL BE LABELED, "COMPLIANT TO RoHS DIRECTIVE 2002/95/EC AND ANNEX II OF DIRECTIVE 2000/53/EC", AND CARTONS WITHOUT THIS LABEL MAY CONTAIN PRODUCT WITH TIN-LEAD.
- PACKAGING INFORMATION: NOT AVAILABLE
- TERMINALS FOR USE WITH .093/(2.36) SERIES HOUSINGS. 1973 & 1973-1 VERSIONS WILL ACCEPT 18 THRU 22 AWG WIRE. 1973-2 VERSION IS FOR USE WITH 14 THRU 18 AWG WIRE AND DOUBLE CRIMPS OF ONE 16 AND ONE 18 AWG OR TWO 18 AWG WIRES.
- INSERTION FORCE: 3.5 LBS. MAX. WHEN TERMINAL IS INSERTED INTO .124/(3.15) DIA. CORE HOLE.
- CONTACT RETENTION: 20 LBS. MIN.
- LOAT: TERMINAL MAY ROTATE IN HOUSING, BUT SHOULD NOT SPIN FREELY WHEN WIRE IS ROLLED BETWEEN FINGERS.

REVISE NOTE 2 EC NO: UCP2009-0059 DRWN:GAVRILL 2008/07/08 CHKD:JBELL 2008/07/10 APPR:FSM/TH 2008/07/10	DESCRIPTION	QUALITY SYMBOLS	GENERAL TOLERANCES (UNLESS SPECIFIED)	DIMENSION STYLE	SCALE	DESIGN UNITS	THIRD ANGLE PROJECTION													
		$\nabla=0$ $\nabla=0$	<table border="1"> <tr> <th></th> <th>mm</th> <th>INCH</th> </tr> <tr> <td>4 PLACES</td> <td>±---</td> <td>±---</td> </tr> <tr> <td>3 PLACES</td> <td>±---</td> <td>±.010</td> </tr> <tr> <td>2 PLACES</td> <td>±0.25</td> <td>±.014</td> </tr> <tr> <td>1 PLACE</td> <td>±0.35</td> <td>±</td> </tr> </table>		mm	INCH	4 PLACES	±---	±---	3 PLACES	±---	±.010	2 PLACES	±0.25	±.014	1 PLACE	±0.35	±	IN/MM	6:1
	mm	INCH																		
4 PLACES	±---	±---																		
3 PLACES	±---	±.010																		
2 PLACES	±0.25	±.014																		
1 PLACE	±0.35	±																		
D1	REV		DRAFT WHERE APPLICABLE MUST REMAIN WITHIN DIMENSIONS	DRAWN BY DATE GWC 1992/06/17	CHECKED BY DATE RW 1992/06/17	TITLE CRIMP TERMINAL, MALE, GROUND PIN, .093 DIA., FOR VARIOUS WIRE SIZES														
				APPROVED BY DATE GWF 1992/06/17	MATERIAL NO. SEE CHART		MOLEX INCORPORATED													
					DOCUMENT NO.	SD-1973-*	SHEET NO. 1 OF 1													
					THIS DRAWING CONTAINS INFORMATION THAT IS PROPRIETARY TO MOLEX INCORPORATED AND SHOULD NOT BE USED WITHOUT WRITTEN PERMISSION															