

Verpackt im Gurt in Anlehnung an DIN IEC 60286-3  
 tape on reel packaging according to DIN IEC 60286-3  
 Verpackungseinheit: 280 Stück  
 packaging unit: 280 pcs

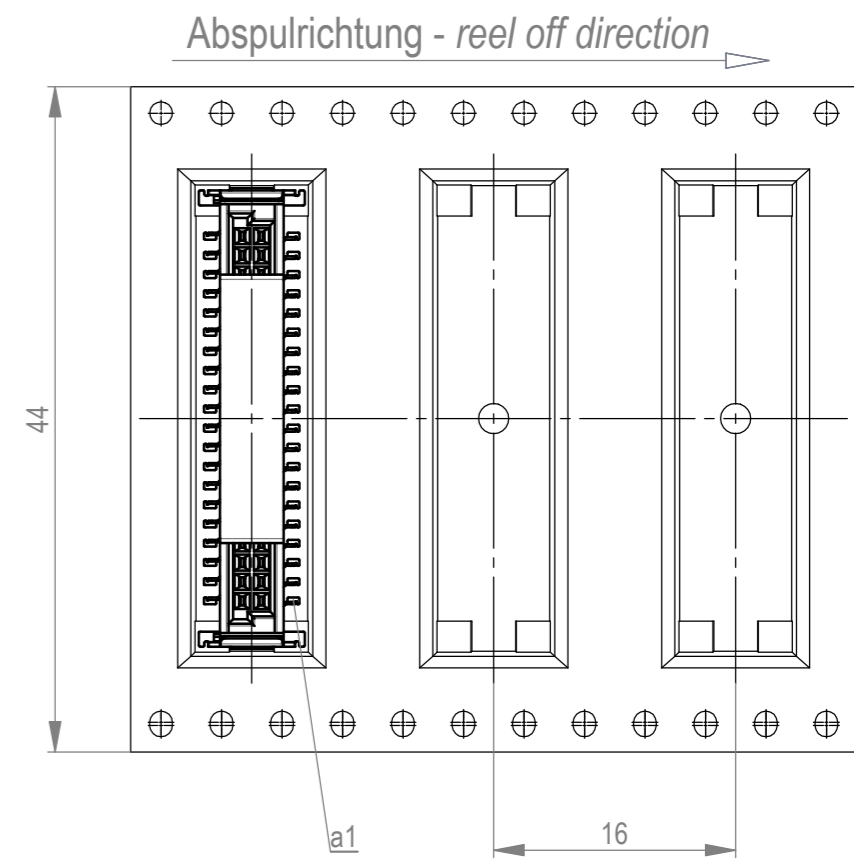

Leiterplatten-Layout Vorschlag für SMT  
 PCB-Layout Proposal for SMT

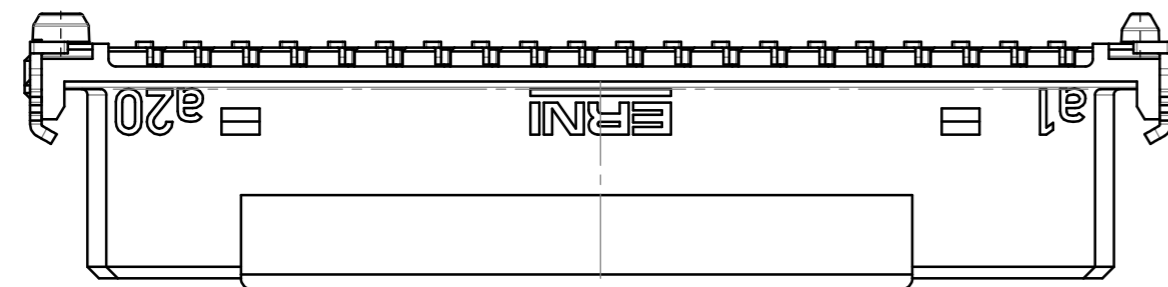
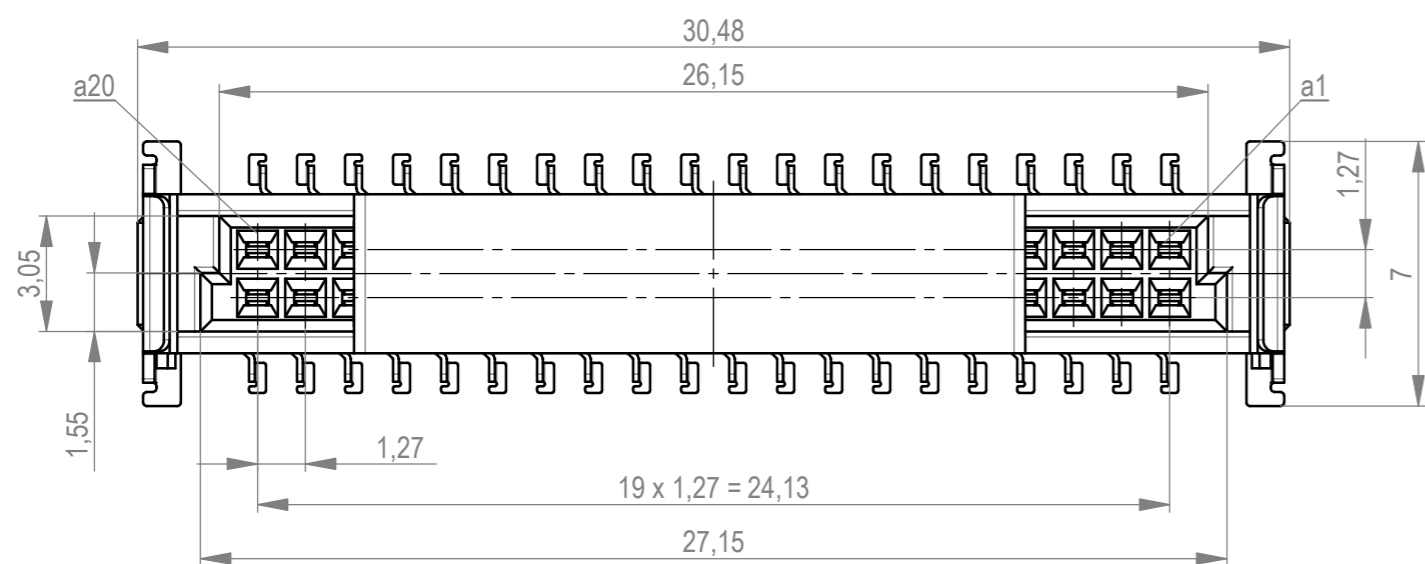
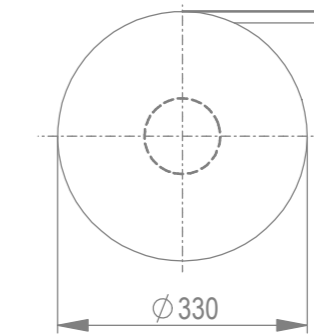
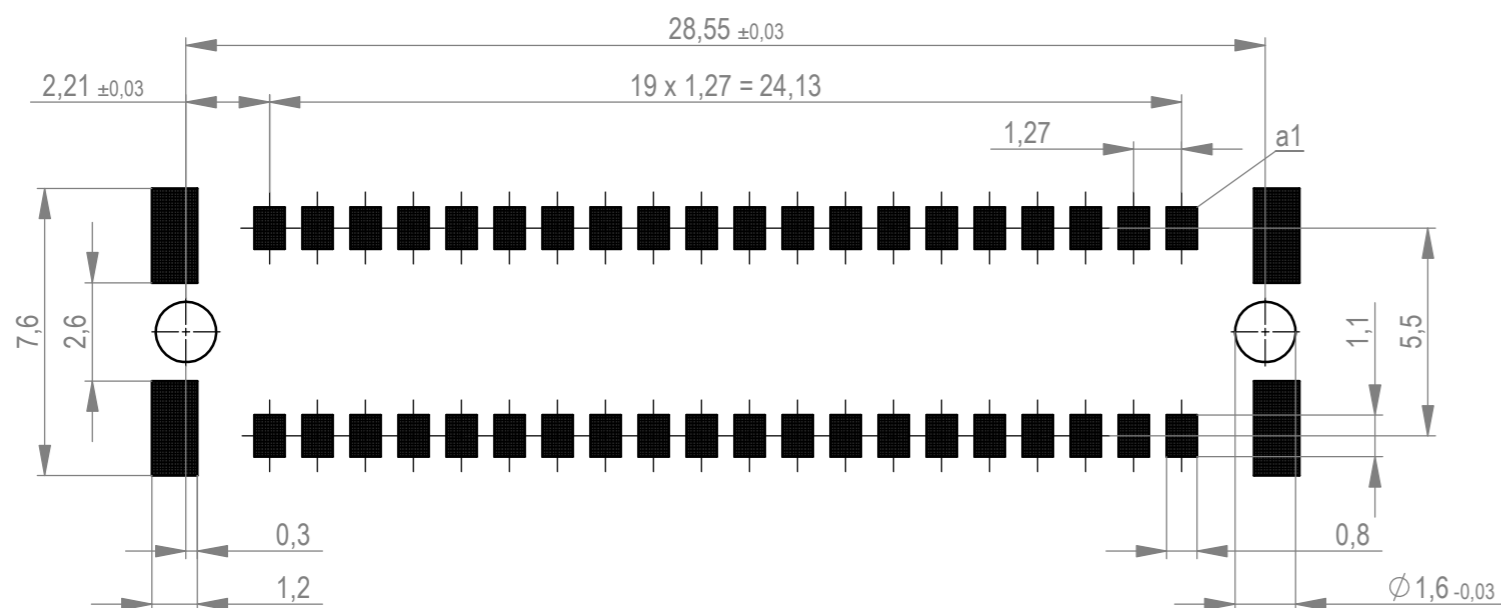

Anforderungsstufe 1  
 performance level 1

Kontaktbereich vergoldet  
 mating area gold plating

Anschlussbereich verzinkt 4-6 µm  
 terminal area 4-6 µm tin plating

Koplanarität der Anschlüsse ≤ 0,1 mm  
 coplanarity area of termination ≤ 0,1 mm

BA 7-13 - 8mm Bauhöhe  
 type7-13 - low profile

Die deutsche Version dieser Zeichnung dient nur zur Erläuterung der Handlung. Bei Abweichungen vom englischen Original gilt das englische Original. This drawing has been created for convenience only and may deviate from the english original. In case of any deviation the English version shall prevail.

Dimension no.	Tolerances ISO 8015	Scale 5:1 Material	
Customer drawing: All rights reserved. Only for information. To ensure that this is the latest version of this drawing, please contact one of the ERNI companies before using.	Subject to modification without prior notice. Drawing will not be updated.	<b>Federl. SMC-B 40-SMD-BA7-13</b> <b>Female SMC-B 40-SMD-type7-13</b>  <b>204632</b>	
c Index	18.06.2021 Date	 ERNI International AG Zürichstrasse 72 8306 Brüttisellen - Zürich Switzerland	I A2  Class SMCB