

⚠ Safety Precautions

- Important Notes on exporting this product or equipment containing this product;
If the end-user or application of this product is related to military affairs or weapons, its export may be controlled by "Foreign Exchange and Foreign Trade Control Law" of Japan where export license will be required before product can be exported from Japan.
- This product is designed and manufactured for use in General Purpose Industrial Equipment and it is not intended to be used in equipment or system that may cause personal injury or death.
- All servicing such as installation, wiring, operation, maintenance and etc., should be performed by qualified personnel only.
- Tighten mounting screws with an adequate torque by taking into consideration strength of the screws and the characteristics of material to which the product will be mounted. Over tightening can damage the screw and/or material; under tightening can result in loosening.
- Install safety equipment to prevent serious accidents or loss that is expected in case of failure of this product.
- Consult us before using this product under such special conditions and environments as nuclear energy control, aerospace, transportation, medical equipment, various safety equipments or equipments which require a lesser air contamination.
- We have been making the best effort to ensure the highest quality of our products, however, some applications with exceptionally large external noise disturbance and static electricity, or failure in input power, wiring and components may result in unexpected action. It is highly recommended that you make a fail-safe design and secure the safety in the operative range.
- If the motor shaft is not electrically grounded, it may cause an electrolytic corrosion to the bearing, depending on the condition of the machine and its mounting environment, and may result in the bearing noise. Checking and verification by customer is required.
- Failure of this product depending on its content may generate smoke of about one cigarette. Take this into consideration when the application of the machine is clean room related.
- Please be careful when using the product in an environment with high concentrations of sulfur or sulfuric gases, as sulfuration can lead to disconnection from the chip resistor or a poor contact connection.
- Do not input a supply voltage which significantly exceeds the rated range to the power supply of this product. Failure to heed this caution may lead to damage of the internal parts, causing smoke and/or fire and other troubles.
- The user is responsible for matching between machine and components in terms of configuration, dimensions, life expectancy, characteristics, when installing the machine or changing specification of the machine. The user is also responsible for complying with applicable laws and regulations.
- Manufacturer's warranty will be invalid if the product has been used outside its stated specifications.
- Component parts are subject to minor change to improve performance.
- Read and observe the instruction manual to ensure correct use of the product.

Repair Consult to the dealer from whom you have purchased this product for details of repair work.
When the product is incorporated to the machine you have purchased, consult to the machine manufacturer or its dealer.

URL Electronic data of this product (Instruction Manual, CAD data) can be downloaded from the following web site;
industrial.panasonic.com/ac/e/

● Contact to : _____

**Panasonic Industry Co., Ltd.,
Industrial Device Business Division**
1-1 Morofuku 7-chome, Daito, Osaka 574-0044, Japan
©Panasonic Industry Co., Ltd.2022
The contents of this catalog apply to the products as of April 2022.

Compact AC Geared Motor

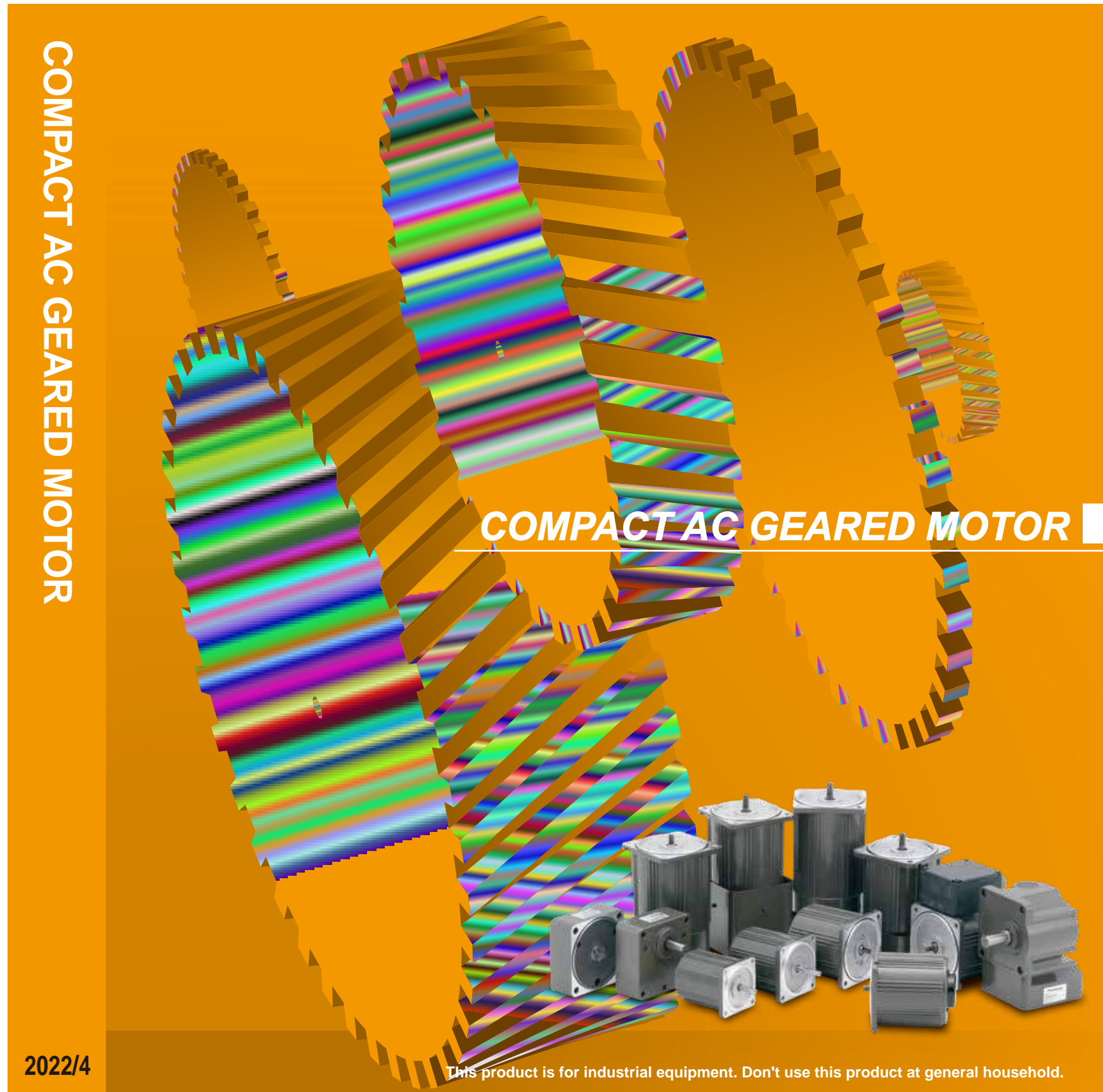

Discontinued products

Speed Controller

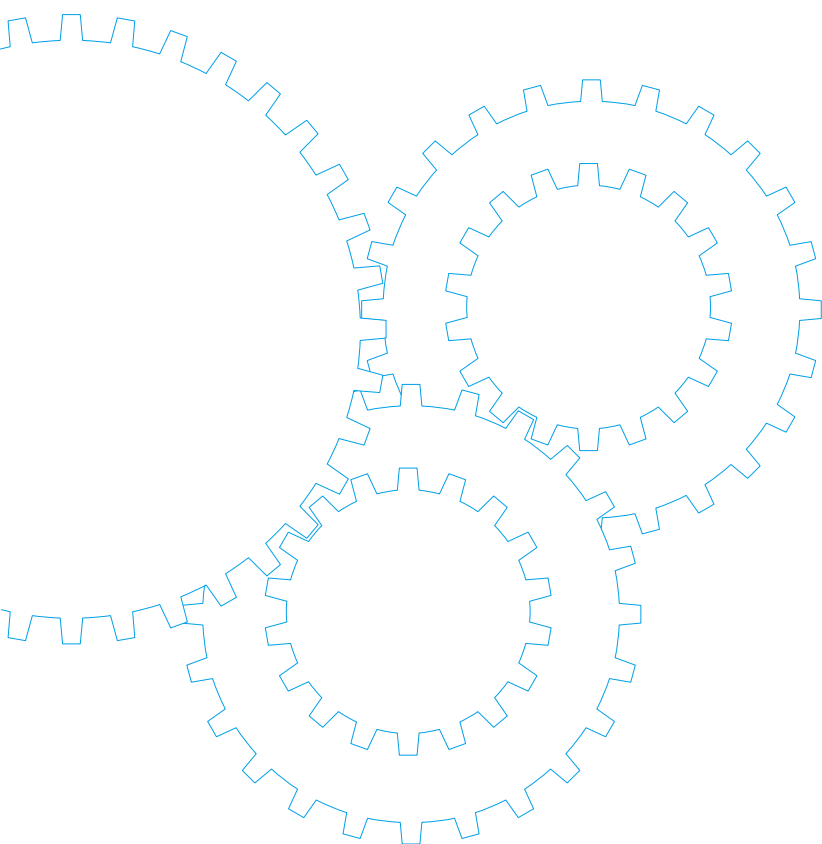

Contents

- Speed Controller Overview E- 2
- Types E- 3
- Product information for each model E- 4

Speed Controller Overview

Orders are no longer accepted later than the end of March 2021.

Overview of Speed Controllers

- These controllers vary speed of compact geared motors.

Product designation

- Separate type speed controller

• EX type

DV **11** **31**
Voltage Code

- 11 : Single-phase 100 V
- 12 : Single-phase 200 V

● Speed controller

Code	Type	Compatible motor output	
		Single-phase 100 V	Single-phase 200 V
31	EX	3 W to 10 W	6 W to 20 W
32		15 W to 40 W	—
34		60 W to 90 W	25 W to 90 W

Speed controller

Orders are no longer accepted later than the end of March 2021.

• Possible combination of speed controller and motor

	Size	Output (W)	Motor			Voltage (V)	Speed controller EX type	
			Certified	Pinion shaft type	Round shaft type			
Variable speed induction motor	60 mm sq. (2.36 inch sq.)	3	----	M61X3GV4L	M61X3SV4LS	100	DV1131	
			6	----	M61X6GV4L	M61X6SV4LS	100	DV1131
		6	----	M61X6GV4Y	M61X6SV4YS	200	DV1231	
	70 mm sq. (2.76 inch sq.)	10	----	M71X10GV4L	M71X10SV4LS	100	DV1131	
			----	M71X10GV4Y	M71X10SV4YS	200	DV1231	
		15	----	M71X15GV4L	M71X15SV4LS	100	DV1132	
			----	M71X15GV4Y	M71X15SV4YS	200	DV1231	
	80 mm sq. (3.15 inch sq.)	15	----	M81X15GV4L	M81X15SV4LS	100	DV1132	
			----	M81X15GV4Y	M81X15SV4YS	200	DV1231	
		25	----	M81X25GV4L	M81X25SV4LS	100	DV1132	
			----	M81X25GV4Y	M81X25SV4YS	200	DV1234	
		40	----	M91X40GV4L	M91X40SV4LS	100	DV1132	
----			M91X40GV4Y	M91X40SV4YS	200	DV1234		
90 mm sq. (3.54 inch sq.)	60	----	M91Z60GV4L	M91Z60SV4LS	100	DV1134		
		----	M91Z60GV4Y	M91Z60SV4YS	200	DV1234		
	90	----	M91Z90GV4L	M91Z90SV4LS	100	DV1134		
		----	M91Z90GV4Y	M91Z90SV4YS	200	DV1234		
	Variable speed reversible motor	60 mm sq. (2.36 inch sq.)	4	----	M6RX4GV4L	M6RX4SV4LS	100	DV1131
				6	----	M6RX6GV4L	M6RX6SV4LS	100
6			----	M6RX6GV4Y	M6RX6SV4YS	200	DV1231	
70 mm sq. (2.76 inch sq.)		10	----	M7RX10GV4L	M7RX10SV4LS	100	DV1131	
			----	M7RX10GV4Y	M7RX10SV4YS	200	DV1231	
		15	----	M7RX15GV4L	M7RX15SV4LS	100	DV1132	
			----	M7RX15GV4Y	M7RX15SV4YS	200	DV1231	
80 mm sq. (3.15 inch sq.)		20	----	M8RX20GV4L	M8RX20SV4LS	100	DV1132	
			----	M8RX20GV4Y	M8RX20SV4YS	200	DV1231	
		25	----	M8RX25GV4L	M8RX25SV4LS	100	DV1132	
			----	M8RX25GV4Y	M8RX25SV4YS	200	DV1234	
		40	----	M9RX40GV4L	M9RX40SV4LS	100	DV1132	
	----		M9RX40GV4Y	M9RX40SV4YS	200	DV1234		
90 mm sq. (3.54 inch sq.)	60	----	M9RZ60GV4L	M9RZ60SV4LS	100	DV1134		
		----	M9RZ60GV4Y	M9RZ60SV4YS	200	DV1234		
	90	----	M9RZ90GV4L	M9RZ90SV4LS	100	DV1134		
		----	M9RZ90GV4Y	M9RZ90SV4YS	200	DV1234		
	Variable speed motor with electromagnetic brake	60 mm sq. (2.36 inch sq.)	6	----	M6RX6GBV4L	----	100	DV1131
				----	M6RX6GBV4Y	----	200	DV1231
70 mm sq. (2.76 inch sq.)		15	----	M7RX15GBV4L	----	100	DV1132	
			----	M7RX15GBV4Y	----	200	DV1231	
80 mm sq. (3.15 inch sq.)		25	----	M8RX25GBV4L	----	100	DV1132	
			----	M8RX25GBV4Y	----	200	DV1234	
90 mm sq. (3.54 inch sq.)	40	----	M9RX40GBV4L	----	100	DV1132		
		----	M9RX40GBV4Y	----	200	DV1234		

* When using a speed controller operative under a wide range of supply voltage (MGSD), the mating motor should be selected according to the voltage of the power supply to be used.

* For combination of C&B (variable speed induction motor) motor and speed controller please refer to the page B-351.



EX type

• Features

<EX type>

- Soft-start/soft-down
Time can be adjusted up to 5 seconds.
Excellent soft-start/soft-down linearity.
- Selectable response
High-stable and high-response can be selected with the internal changeover switch to meet the characteristic of the application.
(Factory setting: high-response)
- Excellent instantaneous stop capability
- Parallel operation
Two or more motors can be controlled from a single control knob.
- Can link with various control systems
Can control motor(s) in conjunction with different controlling systems such as PLC (Programmable Logic Controller). The voltage signal can also be used as control signal.

• Outline drawing

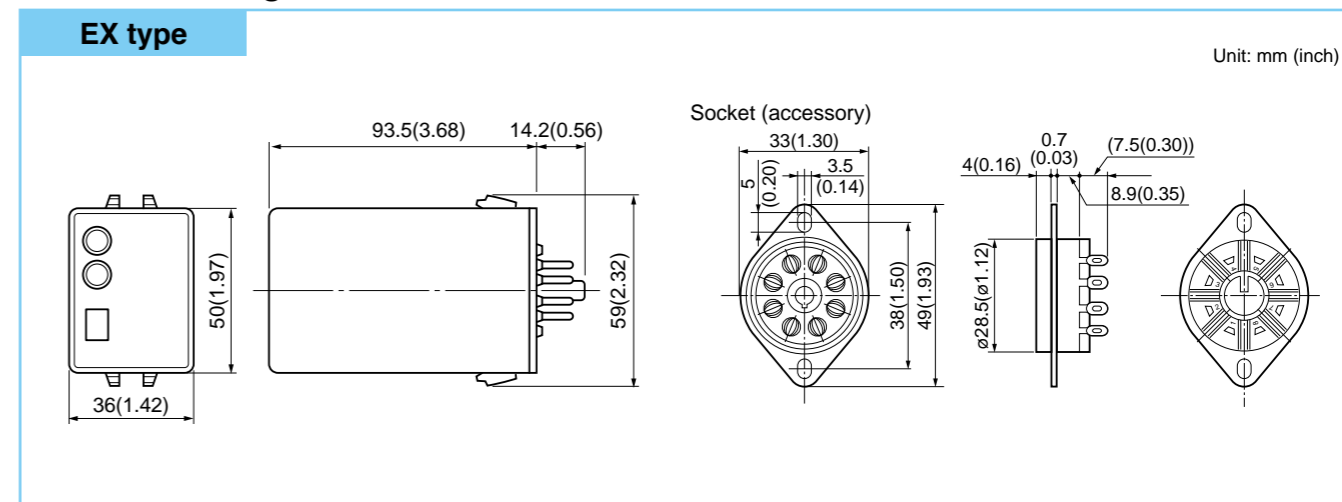

• Setting of Speed

In the case of the MGSD type, the built-in speed reference is used to set the speed. In the case of the EX type, the external speed reference is used to set the speed. The figure below shows an example of the relation between the position of the speed setting knob and the speed of the motor. (Note that there is an approx. 10% fluctuation due to variations in the voltage generation of the circuit and tachogenerator.)

• EX type

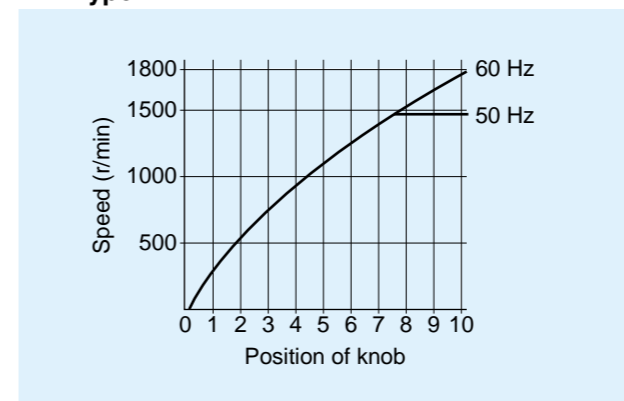

• Standard specification (EX type)

Characteristic	Part No.	EX type				
		DV1131	DV1132	DV1134	DV1231	DV1234
Rated voltage		Single-phase 100 VAC			Single-phase 200 VAC	
Operating voltage range		±10 % (at rated voltage)				
Power frequency		50 Hz/60 Hz				
Rated current		0.4 A	1 A	2.0 A	0.3 A	1 A
Compatible motor output *1		3 W to 10 W	15 W to 40 W	60 W to 90 W	6 W to 20 W	25 W to 90 W
Operation change		High-response			High-stability	
Speed control range		90 r/min to 1400 r/min / 90 r/min to 1700 r/min		50 r/min to 1400 r/min / 50 r/min to 1700 r/min		
Speed variation		5 % or more			3 % or less	
Speed setting		From external controller, e.g. external speed changer *3				
Braking*2		Active while electric braking current is flowing.				
Electric braking time		5 sec typ. The braking current will be turned off before the 5-second limit as the motor stops. (Braking current is 2 to 3 times the rated current.)				
Parallel operation		Enabled				
Soft-start/soft-down capability		Available (typically up to 5 sec (0 to max. speed))				
Operating temperature range		-10 °C to 50 °C				
Storage temperature		-20 °C to 60 °C				

*1 Applicable to Panasonic compact speed variable geared motors. Select motors with applicable output.

*2 Electric braking has no mechanical brake holding mechanism.

To provide brake holding, use our C&B motor or variable speed motor containing electromagnetic brake.
When braking a load having excessively high inertia, durability and life expectancy of motor shaft and gear should be taken into consideration. Use the motor within the allowable inertia.

*3 EX type is supplied with the external speed changer.

7 Wiring diagram (for unidirectional rotation)

- The thick continuous lines represent main circuit. Use conductor of size 0.75 mm² or larger for the main line.
- The thin continuous lines represent signal circuit. Use conductor of size 0.3 mm² or larger in the signal circuit. When the distance from the tachometer generator (TG) is long, use shielded twisted pair cable.

• Soft-start/down control

Soft-start and soft-down times can be adjusted by a single setting. Use this feature to protect the load from shock caused by sharp speed change at startup and shutdown of the motor.
To disable the soft operation, turn the control fully clockwise.

• Maximum speed control

Use this control to adjust the revolving speed when the external speed changer is set at the top speed. Adjust the speed to 1400 (r/min) or below at 50 Hz; or 1700 (r/min) or below at 60 Hz.

• Operation changeover switch

Select "high-stable" or "high-response":

<High-stable>

- Keeps the rotation speed variation low against variation in load.
- Enables a wide range of speed control.
- Suitable for capability control.
- May fail to maintain constant rotation speed upon sharp load change.

<High-response>

- Enables quick response with low hunting.
- Suitable for positioning application.
- May fail to keep rotation speed variation low against variation in load.
- Not suitable for controlling wide range of speed.

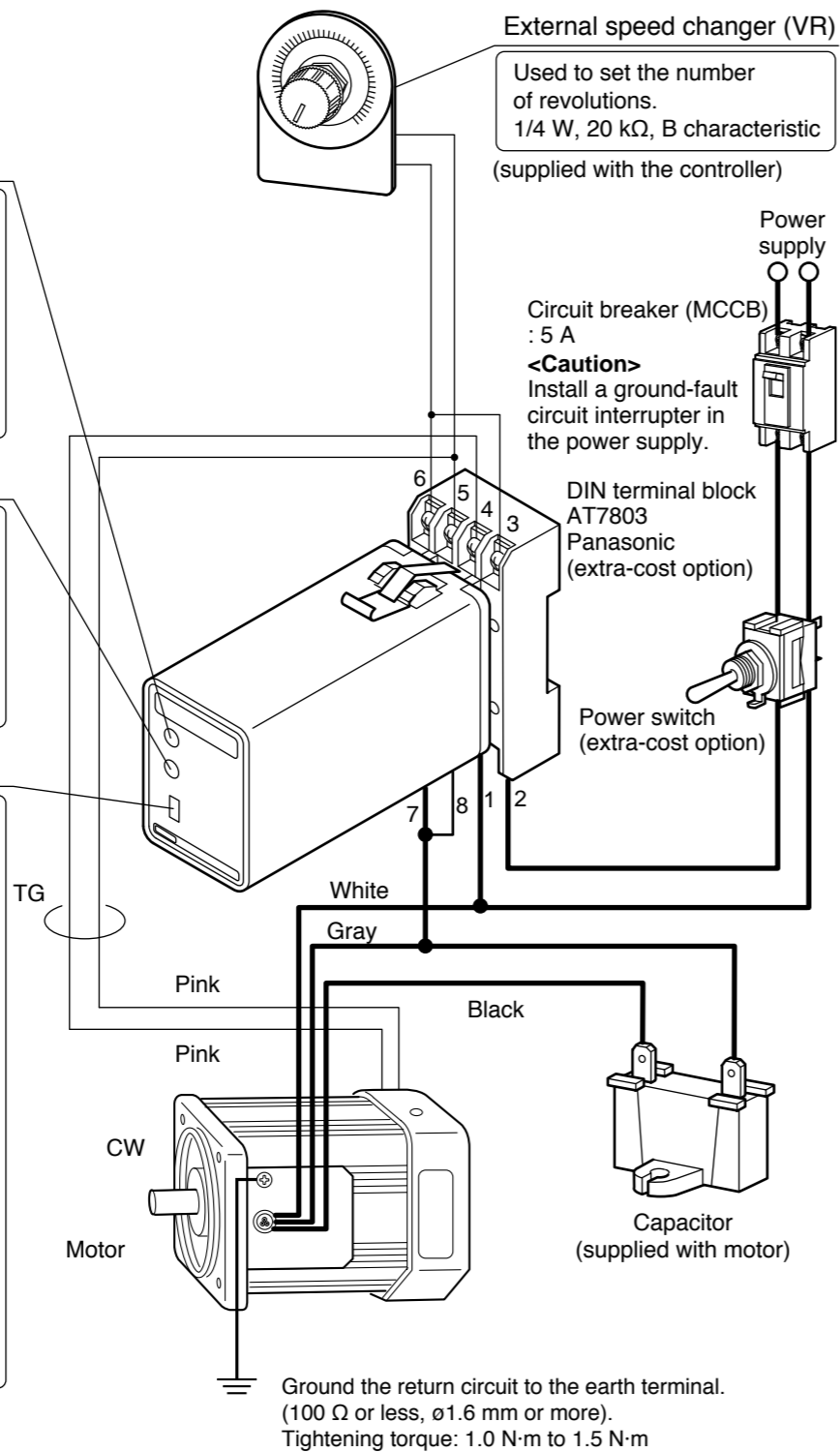

8 Speed change only

Unidirectional rotation

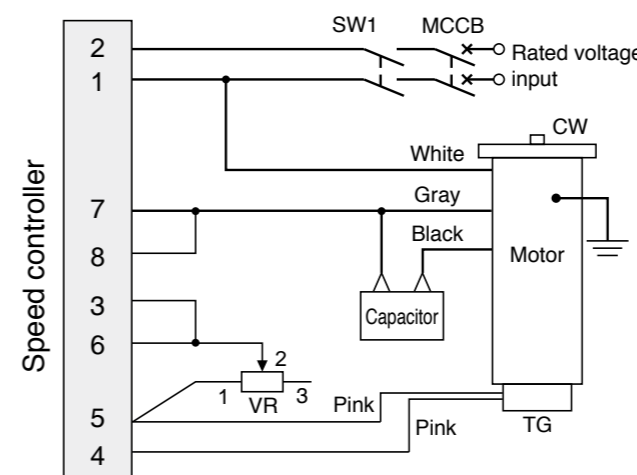

Pin No.

This wiring diagram causes the motor to rotate clockwise when viewed from the motor shaft end.

To run the motor counterclockwise, interchange the connecting point of black and gray leads.

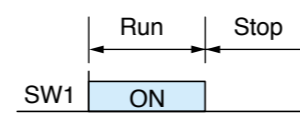

SW1	100 V supply system	5 A or more at 125 VAC
SW2	200 V supply system	5 A or more at 250 VAC
R1+C1	DV0P008A (option)	

Normal/reverse rotation

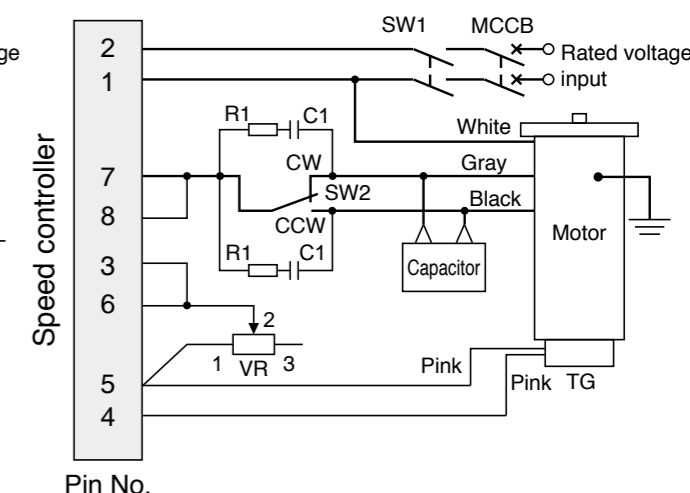

Pin No.

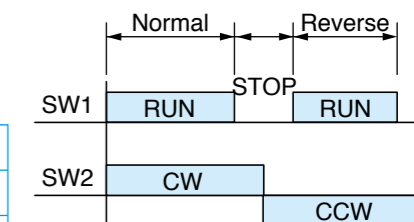

SW1 : Power switch
SW2 : Normal/reverse selector switch

<Precautions>

- To change rotating direction of induction motor:
Provide a motor halt period. Switch over SW2 after complete stop of the motor.
- To change rotating direction of reversible motor:
A motor halt period is not necessary. Switch over SW2 while keeping SW1 turned ON. When configuring SW2 with relay contacts, use a relay having large gap between contacts (e.g. HL relay from Panasonic) to prevent malfunction due to short-circuited capacitor.
- For motors for cooling fan and motors with thermal protector, also refer to page C-20.
- When using independent relay contacts for SW2 to change over normal/reverse, interlock both contacts so that they will not close simultaneously.
- The spark killer consisting of R1 and C1 must be used to protect the relay contacts.

Start/stop control with small signal

- With the external speed changer connected, the motor can be started/stopped with a small signal through SW6 contact while the power switch SW1 (see diagram above) is on. The SW6 provides shorter start-up time than SW1.

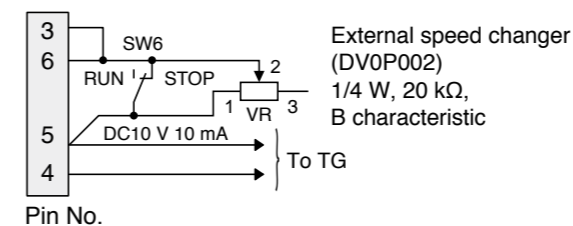

<Precautions>

- Power (SW1) should be turned on at least 0.5 sec before turning on of the start signal (SW6).
- When the motor is not operated for a prolonged time, turn off power switch (SW1).

Operation from maximum speed control

- When no external speed changer is required, the speed can be adjusted from the maximum speed control.

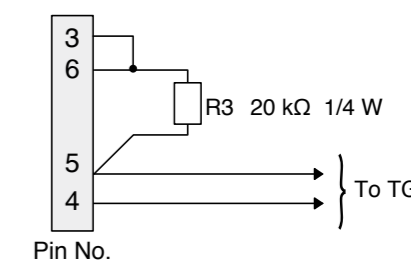

<Precautions>

- Connect a fixed resistor (R3) in place of external speed changer (VR).

9 Unidirectional rotation and electric brake

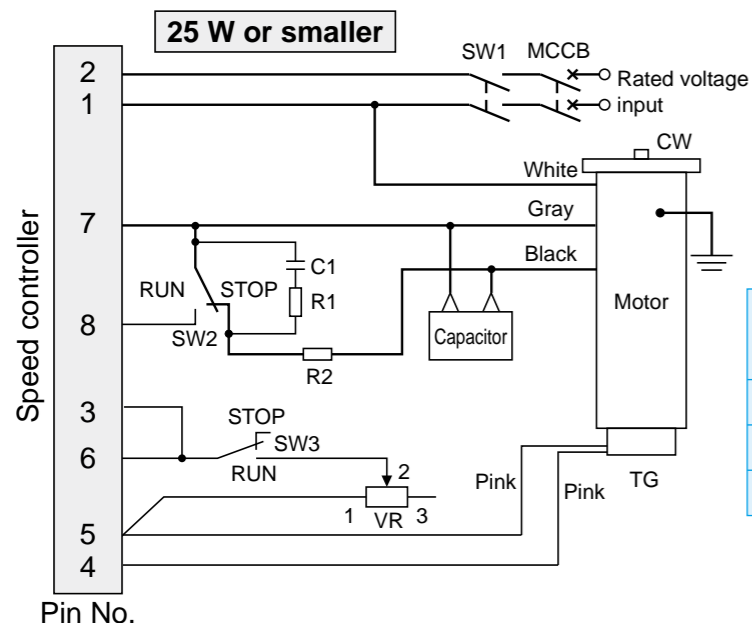

• Connection according to this wiring diagram causes the motor to rotate clockwise when viewed from the motor shaft end. To run the motor counterclockwise, interchange the connecting point of black and gray leads.

SW1	100 V supply system	5 A or more at 125 VAC
SW2	200 V supply system	5 A or more at 250 VAC
SW3	DC10 V 10 mA	
R1+C1	DV0P008A (option)	
R2	DV0P003 (option)	

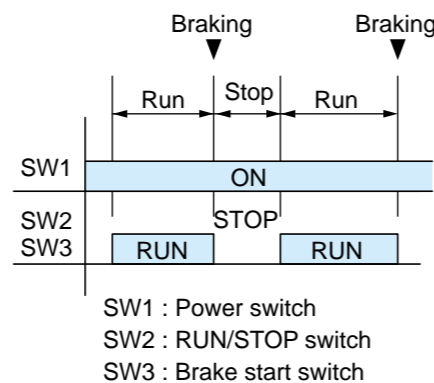
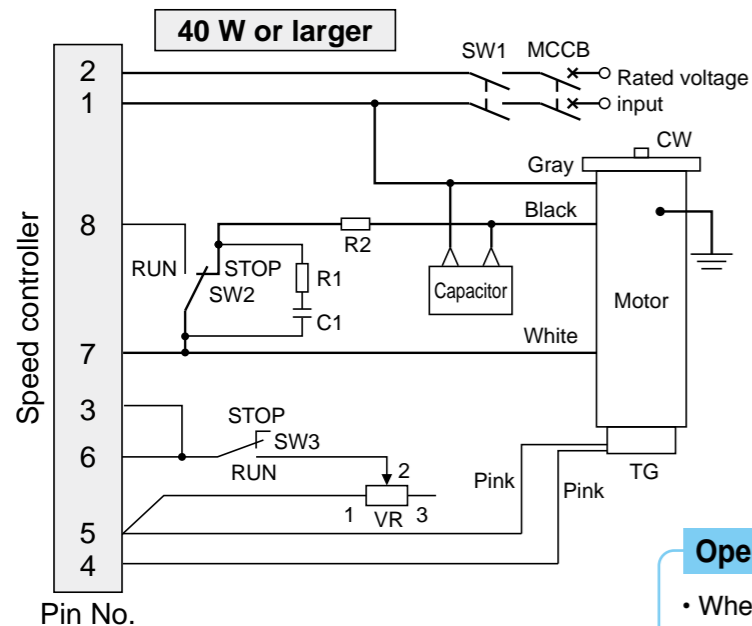

Operation from maximum speed control

• When no external speed changer is required, the speed can be adjusted from the maximum speed control.

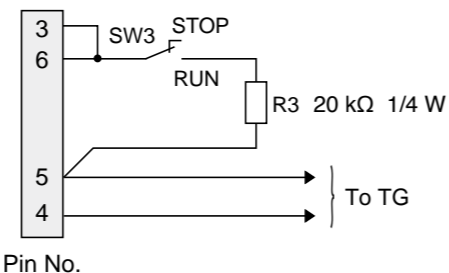

<Precautions>

1. Connect a fixed resistor (R3) in place of external speed changer (VR).

<Precautions>

- When SW2 and SW3 are switched from RUN to STOP, electric braking is applied for approx. 5 sec, or until the motor stops. SW2 and SW3 must be operated simultaneously. Otherwise, abnormal operation occurs (full speed rotation for a short time), causing the motor temperature rises excessively.
- The number of start/stop cycles must be 6 times/min or less.
- When using cooling fan motor or motor with thermal protector, also see page C-20.
- Insert R1 and C1 to protect relay contact.
- R2 restricts discharge current in case of capacitor short circuit during braking.

* Please read your User's manual carefully so that you will understand the operation and safety precautions before attempting to operate the system.

10 Normal/reverse rotation and electric brake

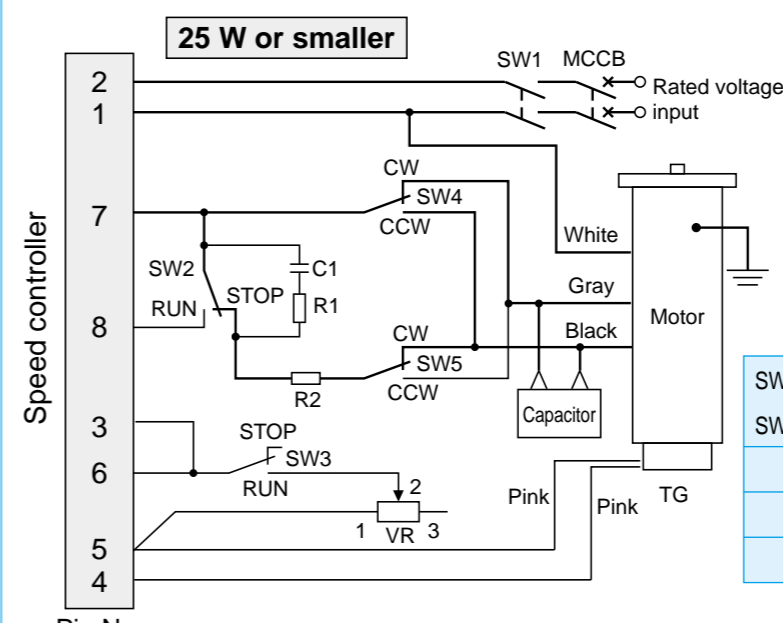

Rotating direction viewed from shaft end	
CW	Clockwise
CCW	Counterclockwise

SW1, SW2	100 V supply system	5 A or more at 125 VAC
SW4, SW5	200 V supply system	5 A or more at 250 VAC
SW3	DC10 V 10 mA	
R1+C1	DV0P008A (option)	
R2	DV0P003 (option)	

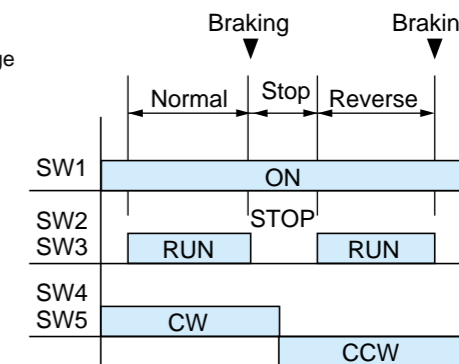
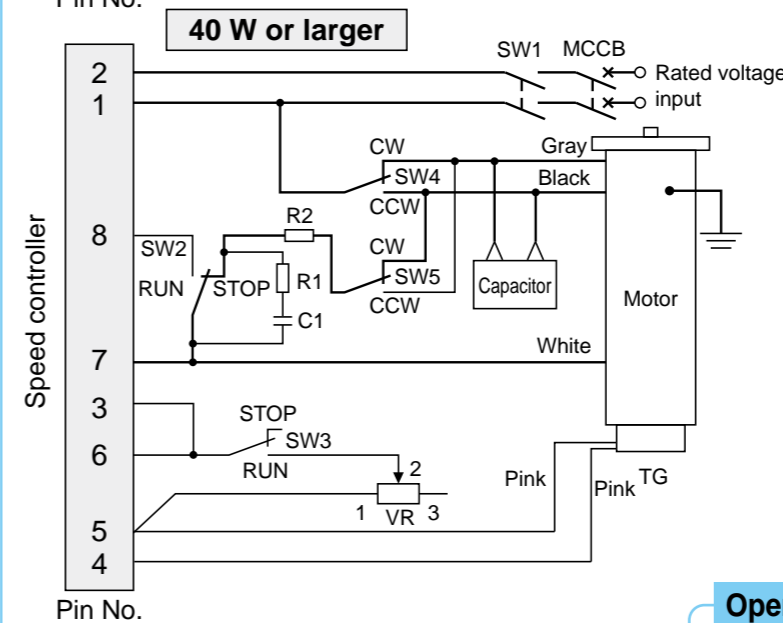

Operation from maximum speed control

• When no external speed changer is required, the speed can be adjusted from the maximum speed control.

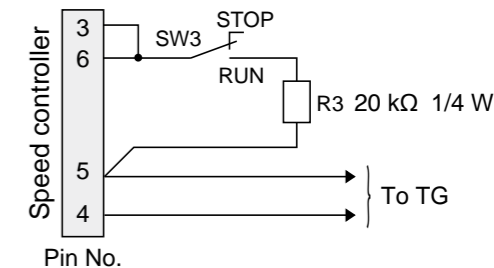

<Precautions>

1. Connect a fixed resistor (R3) in place of external speed changer (VR).

<Precautions>

- When SW2 and SW3 are switched from RUN to STOP, electric braking is applied for approx. 5 sec, or until the motor stops. (Do not operate SW4 and SW5 until the motor stops completely.) SW2 and SW3 must be operated simultaneously. Otherwise, abnormal operation occurs (full speed rotation for a short time), causing the motor temperature rises excessively.
- Do not change the rotating direction (SW4, SW5) while the motor is running.
- The number of start/stop cycles must be 6 times/min or less.
- When using cooling fan motor or motor with thermal protector, also see page C-20.
- Insert R1 and C1 to protect relay contact.
- R2 restricts discharge current in case of capacitor short circuit during braking.

* Please read your User's manual carefully so that you will understand the operation and safety precautions before attempting to operate the system.

11 Multispeed setting application

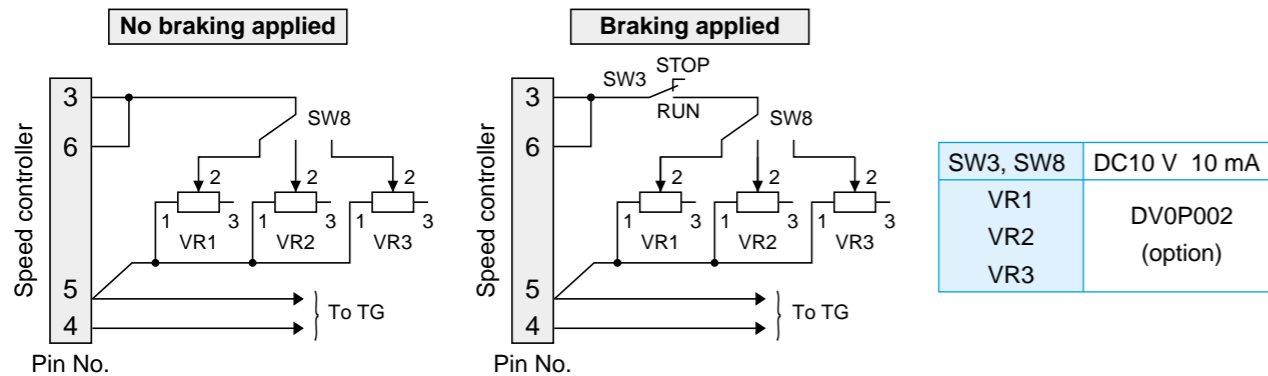

<Precautions>

1. Set external speed changers VR1, VR2 and VR3 to 3 different speeds and select the desired speed from SW8.
2. When activating the brake, simultaneously switch over SW3 and RUN-STOP of other switches.
3. For remaining wirings, refer to the corresponding wiring diagrams.

12 Speed change with analog signal

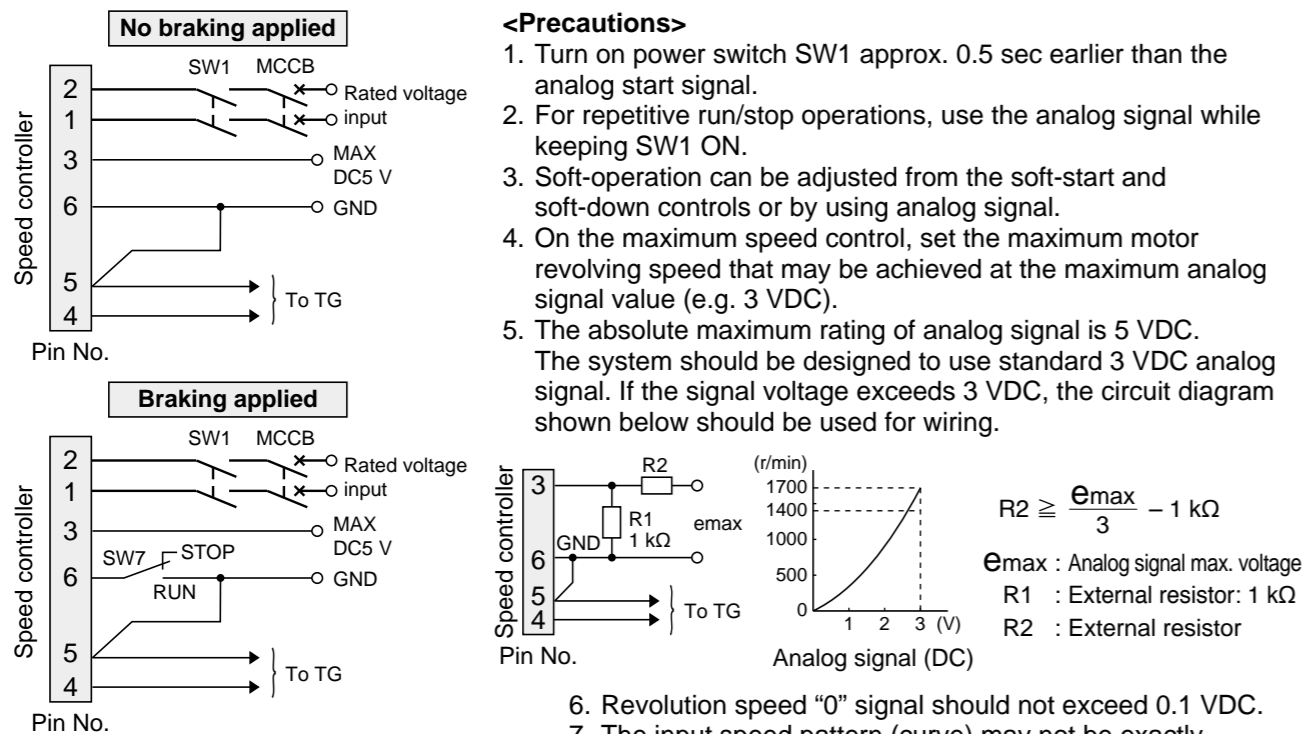

SW1	100 V supply system	5 A or more at 125 VAC
	200 V supply system	5 A or more at 250 VAC
SW7	DC10 V 10 mA	

<Precautions>

1. Turn on power switch SW1 approx. 0.5 sec earlier than the analog start signal.
2. For repetitive run/stop operations, use the analog signal while keeping SW1 ON.
3. Soft-operation can be adjusted from the soft-start and soft-down controls or by using analog signal.
4. On the maximum speed control, set the maximum motor revolving speed that may be achieved at the maximum analog signal value (e.g. 3 VDC).
5. The absolute maximum rating of analog signal is 5 VDC. The system should be designed to use standard 3 VDC analog signal. If the signal voltage exceeds 3 VDC, the circuit diagram shown below should be used for wiring.
6. Revolution speed "0" signal should not exceed 0.1 VDC.
7. The input speed pattern (curve) may not be exactly reflected on the motor speed, due to inertial effect of the load, especially during stop sequence.
8. The percentage ripple of analog voltage signal should be 2 % or less.
9. For other wirings, refer to the corresponding circuit/wiring diagrams.
10. When using the braking feature, motor wiring (pins 1, 7 and 8) should be in accordance with pages C-15 and C-16. To activate braking, switch SW2 and SW7 at the same time. If SW2 is in RUN position while SW7 is in STOP, abnormal operation occurs (full speed rotation for a short time); or if SW7 is in RUN position while SW2 is in STOP, motor temperature rises excessively.

13 Operation through contactless signal

- Small signal relays SW3, SW6 and SW7 can be replaced with transistor.

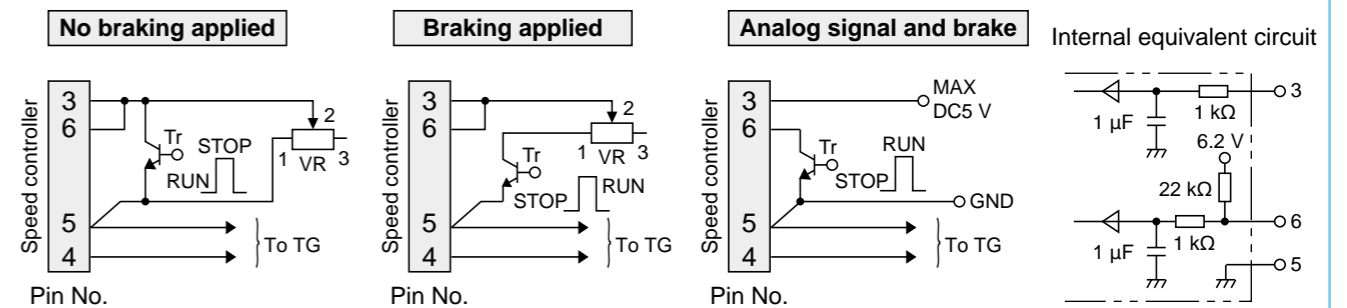

14 Parallel operation through external speed changer

<Precautions>

1. The resistance R_s of the external speed changer VR should be as follows:
 $R_s = 20/N$ (kΩ)
where, N is the number of motors.
2. For synchronous operation or ratio operation, desired revolving speeds must be set from the maximum speed control. Soft-start and soft-down controls and operation changeover switch must be set to the same position.
3. Wirings from the external speed changer VR should be connected to the same pins (No.5 and 6) on the controller.
4. Malfunction may occur as the number of devices operated in parallel increases. To secure correct operation, connect a noise filter to each unit.
5. For other electrical connections, refer to corresponding circuit/wiring diagrams.

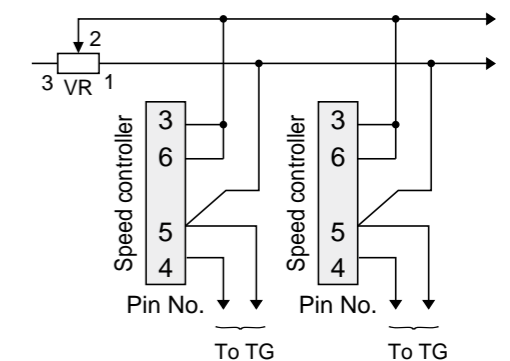

* Please read your User's manual carefully so that you will understand the operation and safety precautions before attempting to operate the system.

* Please read your User's manual carefully so that you will understand the operation and safety precautions before attempting to operate the system.

15 Parallel operation through analog signal

<Precautions>

The input impedance of the controller is approx. 100 kΩ.
The output impedance of the analog signal source should be determined based on the total input impedance of the speed controllers.

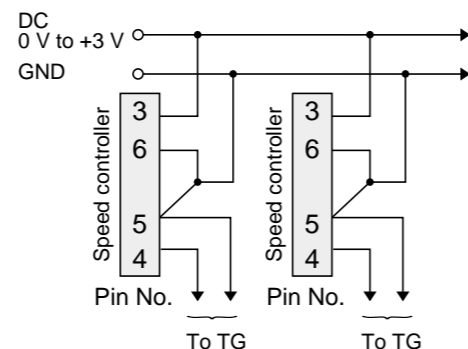

16 Soft-operation

• Soft-start, soft-down

<Precautions>

1. Power switch SW1 should be turned on approx. 0.5 sec before the operation start signal from SW6.
2. When repeating run/stop cycles, turn on/off only SW6 while keeping SW1 turned ON. In this way, the motor can be controlled by using a small signal. To stop operation for a long time, also turn off SW1.
3. Soft-start/soft-down period is the time required for the equipment to start up from stop state to full speed when the external speed changer is set at maximum value.
4. Soft-start/soft-down control, when at the full clockwise position, disables the soft-down function. As the stop signal is input, power supply to the motor is turned off immediately. However, the revolving speed gradually decreases in proportion to the inertia of the load and motor starts free-running stop sequence.
5. Soft-start/soft-down control can set maximum time length of approx. 5 seconds (Typ. at CCW). The setting may be exceeded if the inertia of the load is too large.
6. For other electrical connections, refer to corresponding circuit/wiring diagrams.

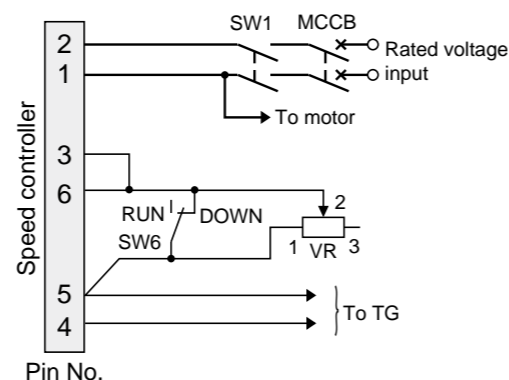

SW1	100 V supply system	5 A or more at 125 VAC
	200 V supply system	5 A or more at 250 VAC
SW6	DC10 V 10 mA	

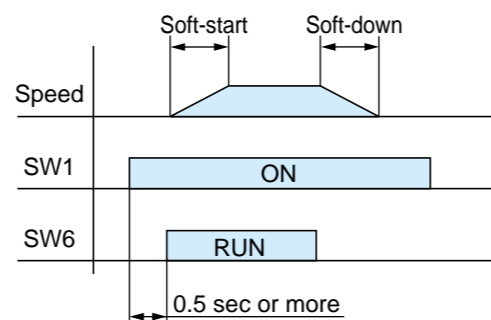

• Soft-start and electric brake

Electrical wirings are the same as for “Unidirectional rotation and electric brake” and “Normal/reverse rotation and electric brake”.
Adjust the soft-start time from the soft-start/down control.
Motor will stop quickly by electric brake despite the volume settings of soft-down operation.

17 Wiring of cooling fan motor and motor with thermal protector

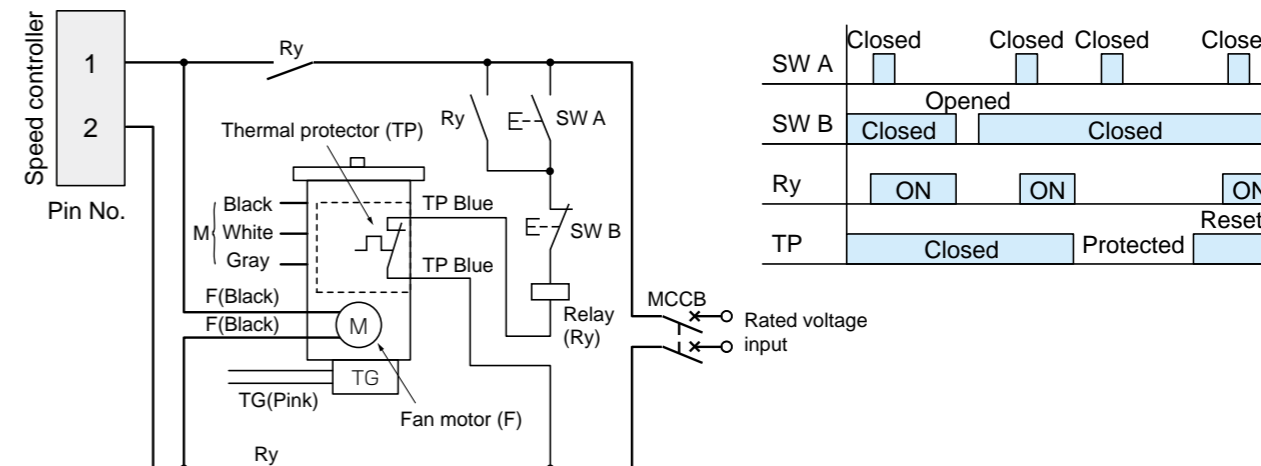

SW A	Momentary N.O. contact	
SW B	Momentary N.C. contact	
Ry	100 V supply system	125 VAC 5 A or more 3a contact
	200 V supply system	250 VAC 5 A or more 3a contact

<Precautions>

1. The thermal protector (TP) is an automatic reset type. To prevent hazards caused by restarting, connect the TP as shown above. Don't connect TP directly to the power supply.
2. Once the TP operates, cooling period is required before the operation can restart.
3. Connect the cooling fan motor (F) across pins 1 and 2 on the power terminal.
4. Motor (M) and tachometer generator (TG) should be connected according to corresponding wiring diagram shown on page C-14 to C-19.

18 Wiring to electromagnetic brake

• Variable speed motor with electromagnetic brake should be wired as shown below.

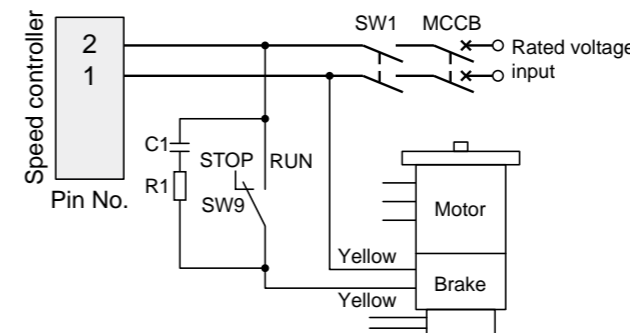

SW1	100 V supply system	5 A or more at 125 VAC
SW9	200 V supply system	5 A or more at 250 VAC
R1+C1	DV0P008A (option)	

<Precautions>

1. SW9 should be switched to RUN or STOP at the same time as the other switches are switched to RUN or STOP.
If the other switches are set to RUN while the brake is energized (SW9 in STOP position), the motor will generate heat.
2. For other wirings, refer to the corresponding circuit/wiring diagrams.
If the application is speed change without using electric braking (page C-14), perform wiring according to “Start/stop control with small signal”.