

# 90022-AS



## SMT SPRING LOADED CONTACT

*Engineered for Success*

Assembly: SMT  
Height: 4.25mm (.167")  
Stroke: 1.4mm (.055")

**ORDER AS:  
90022-AS**

### APPLICATION NOTES:

#### PRODUCT DESCRIPTION:

Preci-Dip Spring Loaded contact SMT termination for reflow soldering. Every Preci-Dip spring contact is Swiss precision machined and assembled for highest quality, performance and long product life.

#### PRODUCT PACKAGING:

This product is sold in bulk or on tape and reel. It can be supplied assembled in an insulator. Let us help you with your custom packaging request.

#### HOW TO USE THIS PRODUCT:

This product is ideal for PCB surface mount applications on .100" grid. With solid one-piece body construction, These spring loaded contacts are typically used in docking stations, recharging stations, module stacking and pluggable SLC requirements.

#### CAN I CUSTOMIZE THIS PRODUCT?

Preci-Dip welcomes custom design requests. Please provide us your spring force and packaging requirements. Call today to discuss your application.

Visit us at [WWW.PRECI-DIP.COM](http://WWW.PRECI-DIP.COM)

Temperature rise [°C]

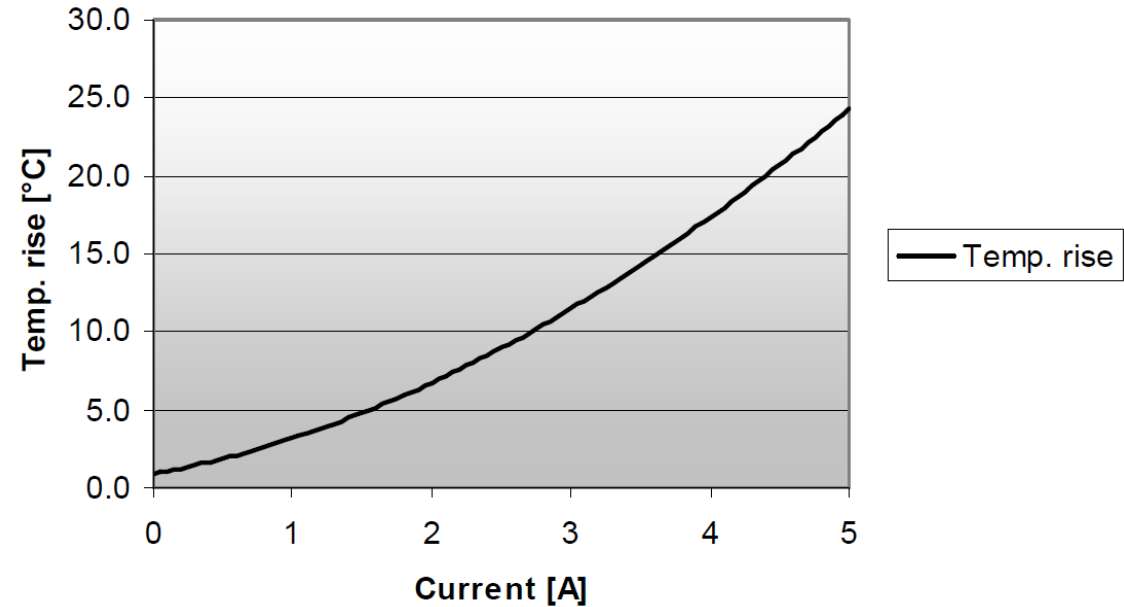

Current: 3A continuous @ 10 ° C rise

Surface Mount  
Base

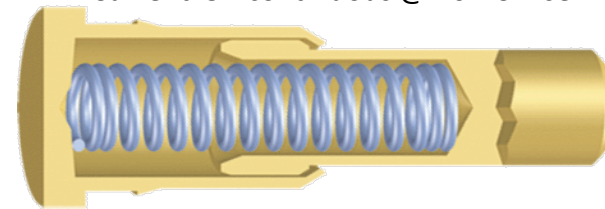

Piston

Spring

#### HOW IT WORKS:

Strong, secure and featuring one piece solid body construction, there are no capped components at the bottom of this spring contact. No seams for solder to wick inside the shell.



preci-dip



# 90022-AS

## SMT SPRING LOADED CONTACT

Visit us at [WWW.PRECI-DIP.COM](http://WWW.PRECI-DIP.COM)



preci-dip

### SPECIFICATIONS:

#### MATERIAL:

Piston: Brass Alloy, plated 0.5um (20μ") Gold  
Barrel: Brass Alloy, plated 0.5um (20μ") Gold  
Spring: Stainless Steel

#### ELECTRICAL:

Current: 3A continuous @ @ 10 ° C rise. 5A Peak.  
Rated Voltage: 100Vrms 150Vdc  
Contact Resistance: 20mΩ max..

#### ENVIRONMENTAL

Operating Temperature: -55 to 125° C  
Passed Vibration Test Sinusoidal per IEC 512.6d / IEC 68-2-6  
Passed Shock Test per IEC 512.6d / IEC 68-2-27  
No electrical discontinuity greater than 1μs.

#### SPRING CONTACT FEATURES:

- \* Swiss Experience
- \* Swiss Quality
- \* Swiss precision machined components
- \* Seamless shell construction
- \* Press-fit barb on barrel for packaging
- \* Gold plating for corrosion resistance.
- \* Smooth piston travel
- \* High quality, smooth surface finish on tip of piston.
- \* Strong and durable construction
- \* RoHs

This product can be assembled in SIP or STRIP, and provided on Tape and Reel. Please inquire if interested.

080715 Rev 3

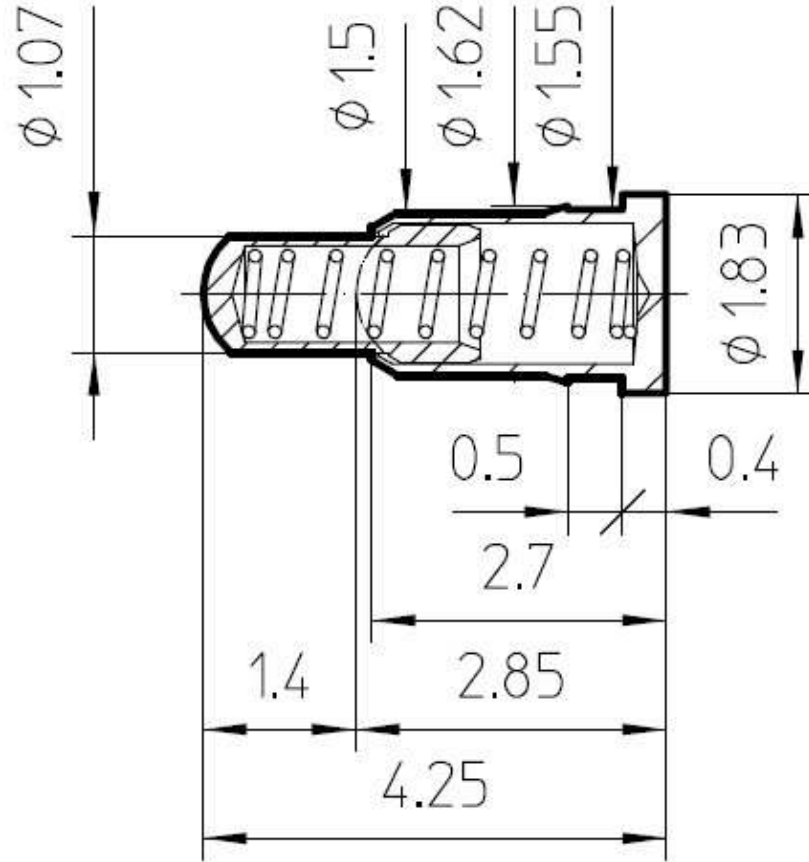

#### MECHANICAL

Durability: Minimum 40,000 cycles.  
Stroke: 1.4mm (.055")  
Working Travel: 4.25-2.9mm  
(.167-.114")  
Force: Initial .25N  
Half-Stroke .6N

#### HOW TO CUSTOMIZE A SPRING CONTACT

##### Specify:

1. Stacking distance between boards
2. Desired piston stroke
3. Desired spring force
4. Desired current rating.
5. Termination style SMT, Solder tail, Wire
6. Desired Cycle life



[WWW.DIGIKEY.COM](http://WWW.DIGIKEY.COM)

