

SERIES 68B Hall Effect Rocker Switch

FEATURES

- Choice of ratiometric analog or PWM outputs
- Sealed to IP67 dynamic - even during actuation
- Rugged industrial design suited for outdoor use
- Provides positive tactile feedback in any environment
- Long operational life
- Redundant output for safety
- Available with 26° detent and 36° latching, friction hold, or spring return (no detent)
- Choices of cable length
- Choices of accent color

APPLICATIONS

- Dash-panel and armrest controls
- Hydraulic fluid flow control
- Engine speed control
- Heavy duty industrial equipment
- Remote control belly boxes



DIMENSIONS in inches, [mm]

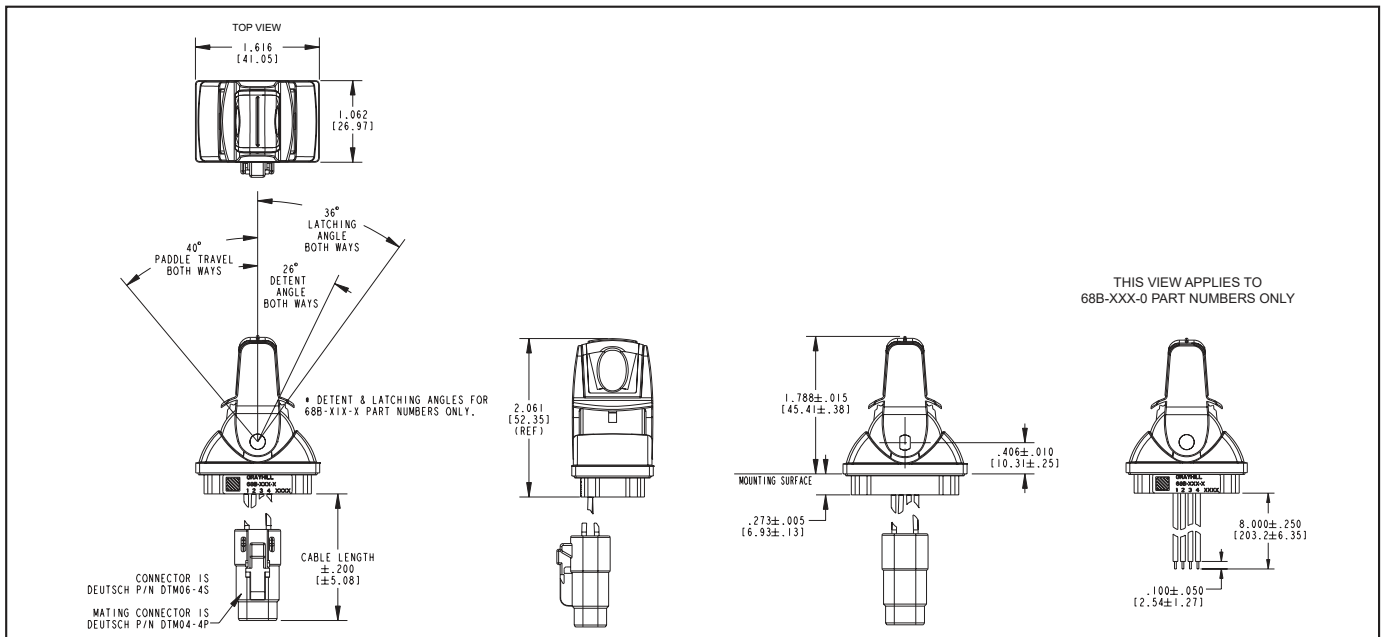

MOUNTING PANEL OPTIONS

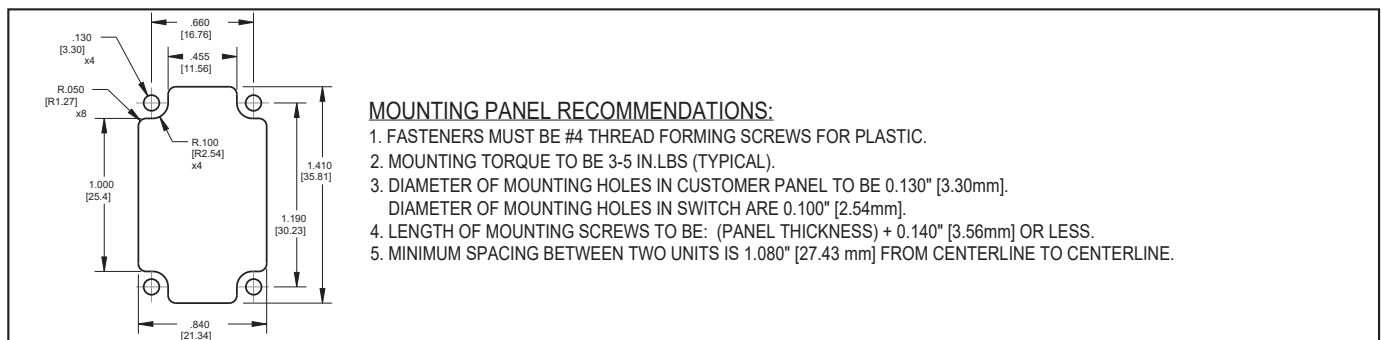

Joysticks

BLOCK DIAGRAM

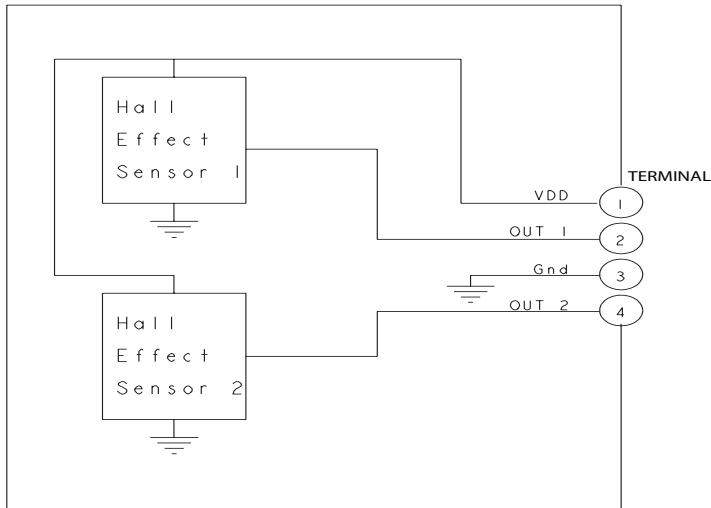

PINOUT AND WIRE COLOR CHART

PINOUT FOR DEUTSCH CONNECTOR
P/N DTM06-4S

PINOUT		
TERMINAL #	FUNCTION	WIRE COLOR
1	VDD, +5V NOMINAL	RED
2	OUTPUT, SENSOR 1	WHITE
3	GROUND	BLACK
4	OUTPUT, SENSOR 2	GREEN

ANALOG OUTPUT WAVEFORM

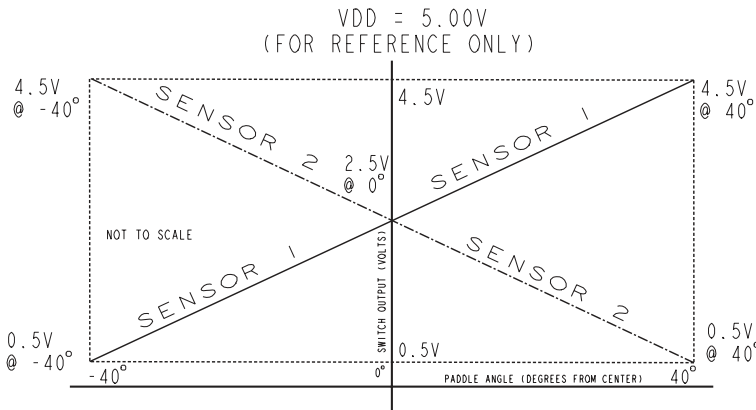

POSITIVE/NEGATIVE DIRECTION REFERENCE

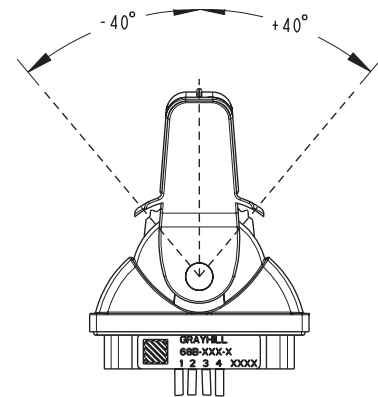

PWM OUTPUT WAVEFORM

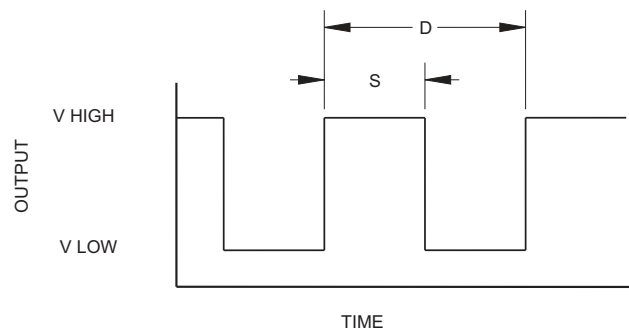
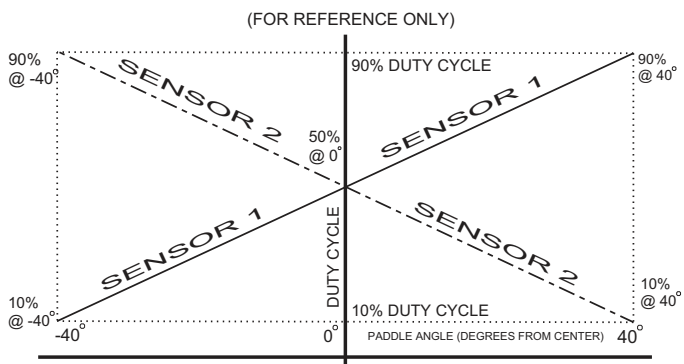

FAILURE INDICATIONS*		
FAILURE MODE	PWM FREQUENCY	DUTY CYCLE
SENSOR ERROR	50% ± 37.5 Hz	85% OR 95%
OVERVOLTAGE	50% ± 37.5 Hz	75%
UNDERVOLTAGE	50% ± 37.5 Hz	100%

* IN CASE OF ERROR THE SENSOR CHANGES THE PWM FREQUENCY TO 50% OF THE NORMAL OPERATING FREQUENCY

DUTY CYCLE DEFINED AS THE RATIO BETWEEN THE HIGH TIME (S) AND THE PERIOD (D) OF THE PWM SIGNAL AS SHOWN IN FIGURE ABOVE.

Joysticks

SPECIFICATIONS

Electrical Specifications

Operating Voltage on Pin 1 (V_{DD}): 5.0V ± 0.5V

Absolute Maximum Voltage* on Pin 1

(V_{DD}): -18 V min, +18 V max (t < 1 h)

Operating Current: 15 mA typ., 20 mA, max.

Analog

Output Voltage is Analog (Ratiometric to Operating Voltage)

Output at Center Position: 50% V_{DD}

Output at Full Travel: 10% V_{DD} or 90%

V_{DD} depending on configuration

Output Voltage Tolerance:

± 3% V_{DD} at full travel

± 5% V_{DD} at center position

Output Current: 1 mA, max.

Recommended Load: 10 K Ohm pull-down resistor.

Sensor Error: When a sensor error occurs, the output goes to < 4% of operating voltage (V_{DD})

*Exceeding the Absolute Maximum Voltage may result in permanent damage to the device. This is a stress rating only and functional operation of the device at those or any other conditions above those indicated in the operation listings of this specification is not implied.

PWM

Time from Power-up to Signal Out: 8mS

Max

PWM Frequency Tolerance: ± 15%

Center Position Duty Cycle: 50 ± 5%

End Position 1 Duty Cycle: 10 ± 3%

End Position 2 Duty Cycle: 90 ± 3%

VOL: 0.5V typ. @ I < 5mA; V_{DD} = 5.00V

VOH: 4.9V typ. @ I < -1.2mA; V_{DD} = 5.00V

Recommended Load: 1.0 K Ohm pull-up resistor.

Physical & Mechanical Ratings

Vibration: Random, meets MIL-STD-810G, Method 514.6, Procedure I

Mechanical Shock: Meets MIL-STD 202, Method 213B Test Condition A

Transit Drop: Meets MIL-STD-810G, Method 516.6, Procedure II

Terminal Strength: 10 lbs. minimum, tested per MIL-STD-202, Method 211A

Push-Out Force: 45 lbs. minimum

Pull-Out Force: 45 lbs. minimum

Paddle Impact: 0.5 lbs. weight dropped 3x from height of 0.3m

Paddle Side-Load: 45 lbs. minimum

Mounting Torque: 3-5 in-lbs (Typical)

Return to Center Life: 2 million cycles minimum**

Detent Life: 200,000 cycles minimum

Latching Life: 200,000 cycles minimum

Friction Hold Life: 200,000 cycles minimum

** One cycle is defined as full travel from the center to the +40° direction, then full travel to the -40° direction, then return to the center

Environmental Ratings

Seal: IP67 as mounted

Altitude: Meets MIL-STD-810G, Method 500.4, Procedure I

Thermal Shock: Meets MIL-STD-810G, Method 503.4, Procedure I

Operating High Temperature: +85°C, Meets IEC 68-2-2, Test Aa

Operating Low Temperature: -40°C, Meets IEC 68-2-1, Test Aa

Storage High Temperature: +100°C, Meets IEC 68-2-2, Method Aa

Storage Low Temperature: -55°C, Meets IEC 68-2-1, Method Aa

Damp Heat Cycle: Meets IEC/EN 60068-2-38 Z/AD

Humidity, 85/85: Meets MIL-STD 202, Method 103B, 500 hours

Solar Radiation: Meets ISO 4892-2, Method A, Cycle 1, 1000 hours

Chemical Resistance: Meets IEC 60068-2-74

Salt Fog: Meets MIL STD 810G

Dielectric: Meets MIL-STD-202G, Method301

Insulation Resistance: Meets MIL-STD-202G, Method 302

Materials and Finishes

Paddle: Thermoplastic with elastomer finger grip

Cable Assembly: 22AWG stranded, tin-coated copper wires in PVC insulation

Connector Body: Thermoplastic

Terminals: Nickel

RoHS Compliant

EMC Ratings

Radiated Immunity: At 3 orientations, meets ISO11452-5 (140 V/M, 10KHz-2MHz), ANSI/ASAE EP455 5.16 (100 V/M, 2-200MHz), ISO 11452-2 (140 V/M, 200MHz-1GHz), and ISO 11452-2 (50 V/M, 1GHz-2.7GHz).

Conducted Immunity: Bulk Current Injection Meets ISO11452-4, SAE J1113-4 (120 mA, 1MHz-400MHz)

Radiated Emissions: Meets CISPR25, Class 3 (150kHz - 54MHz), CISPR 16.2.3, Class B (30-1000 MHz) and ISO13766, level 6db (30MHz - 1GHz)

Conducted Emissions: Meets CISPR 25, Class 5

Electrostatic Discharge: Meets ANSI/ASAE EP455 5.12, Level 1

Power Frequency Magnetic Field: Meets IEC 61000-4-8, 30 A/m

ORDERING INFORMATION

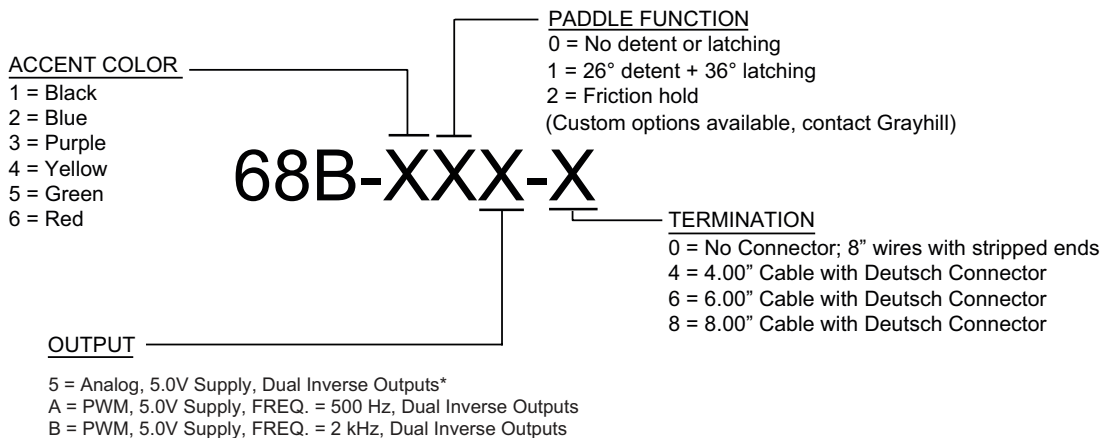

*OUTPUT VOLTAGE IS PROPORTIONAL TO VDD