

REVISIONS					
P	LTN	DESCRIPTION MODIFICATIONS	DATE	OWN	APPR
C		FIRST ISSUE - TE DRW BOARD	29JUN2005	PCS	JDr
D		INTER BOX LOCKING DEVICE MODIFICATION	21DEC2006	PCS	JDr
E		REFERENCE PRONER DELETED	29NOV2010	PCS	JDr
F		TOLERANCE UPDATED FR DIM REF 10 AND 32	29MAY2018	DB	XR

ECHELLE 1000
 SCALE : 1000

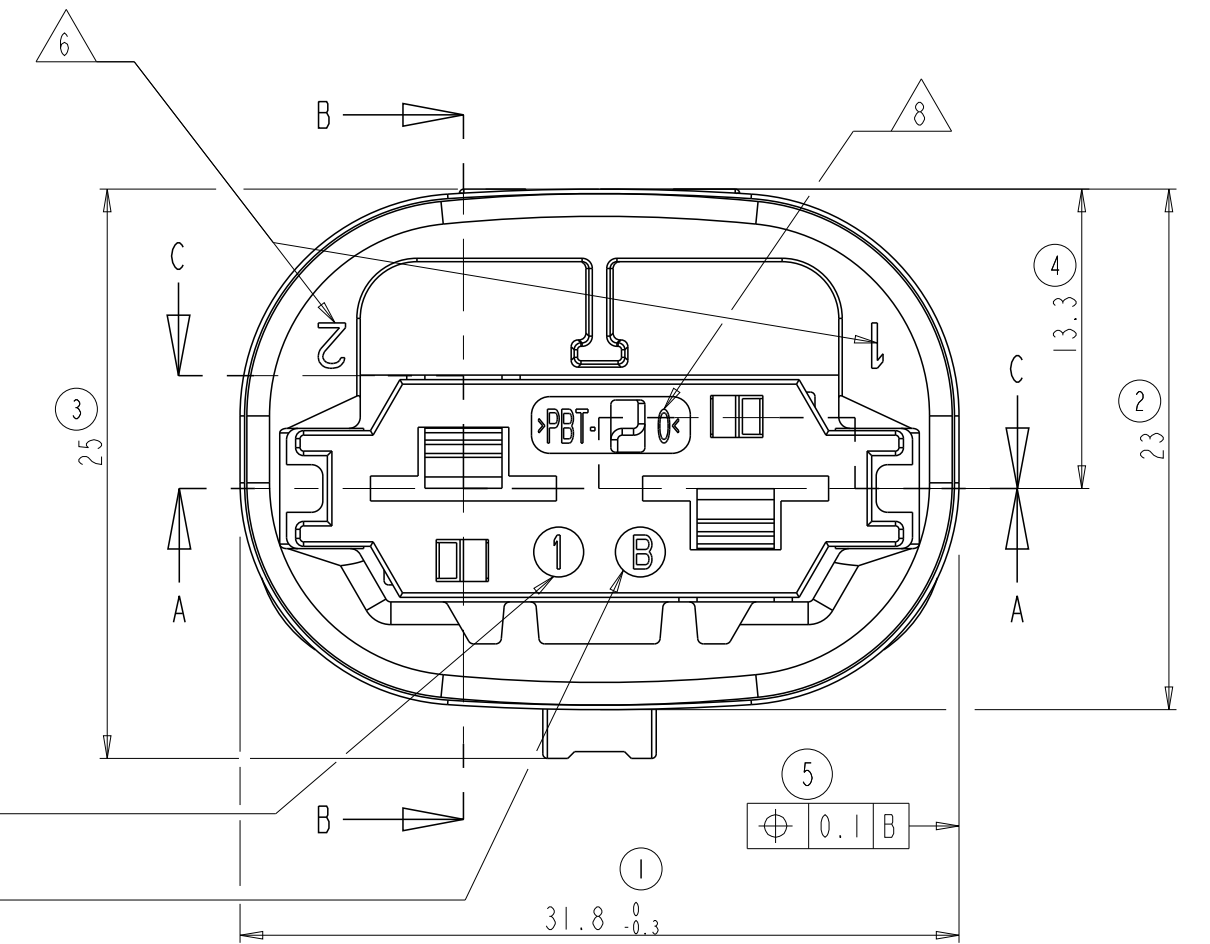
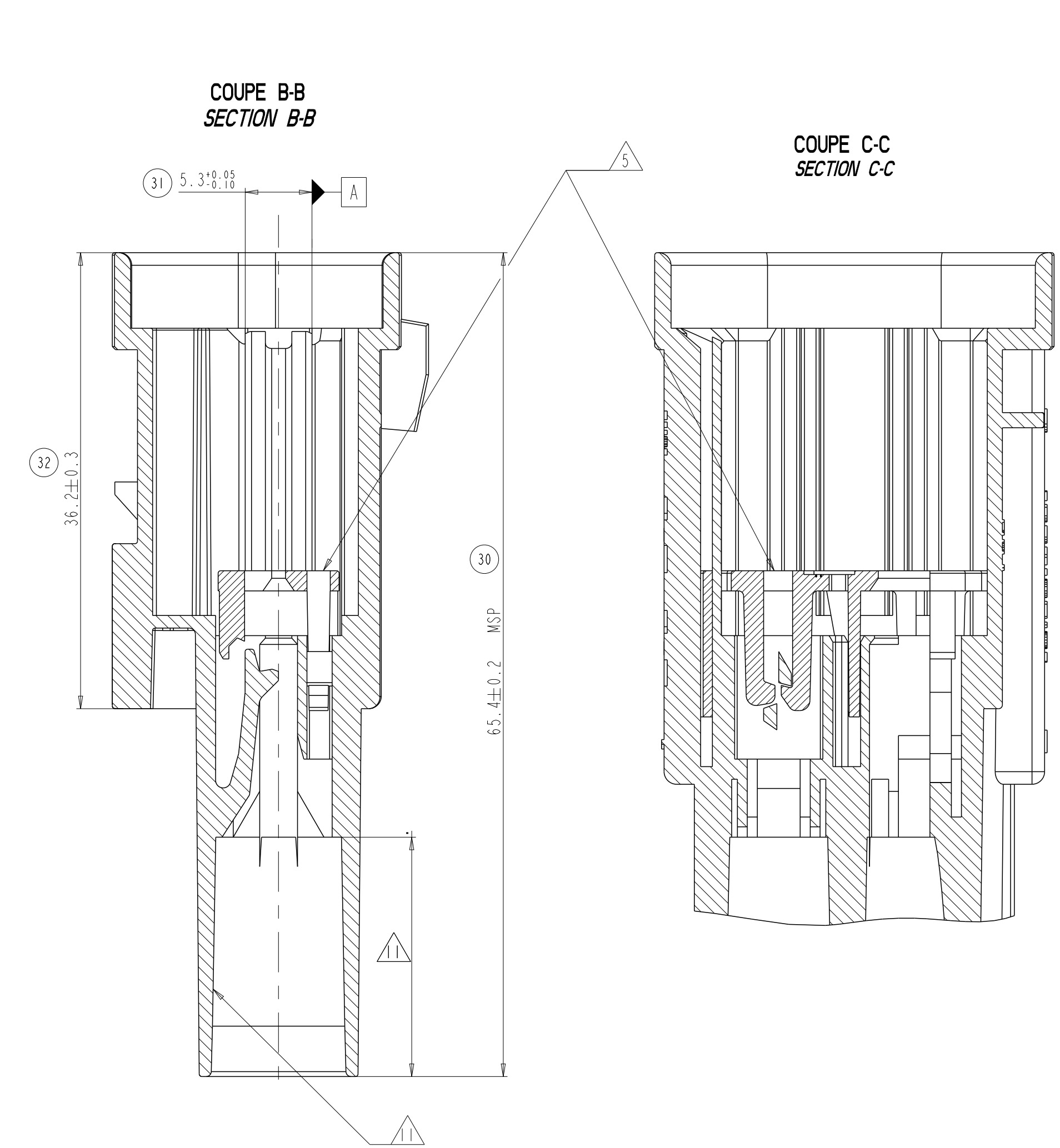
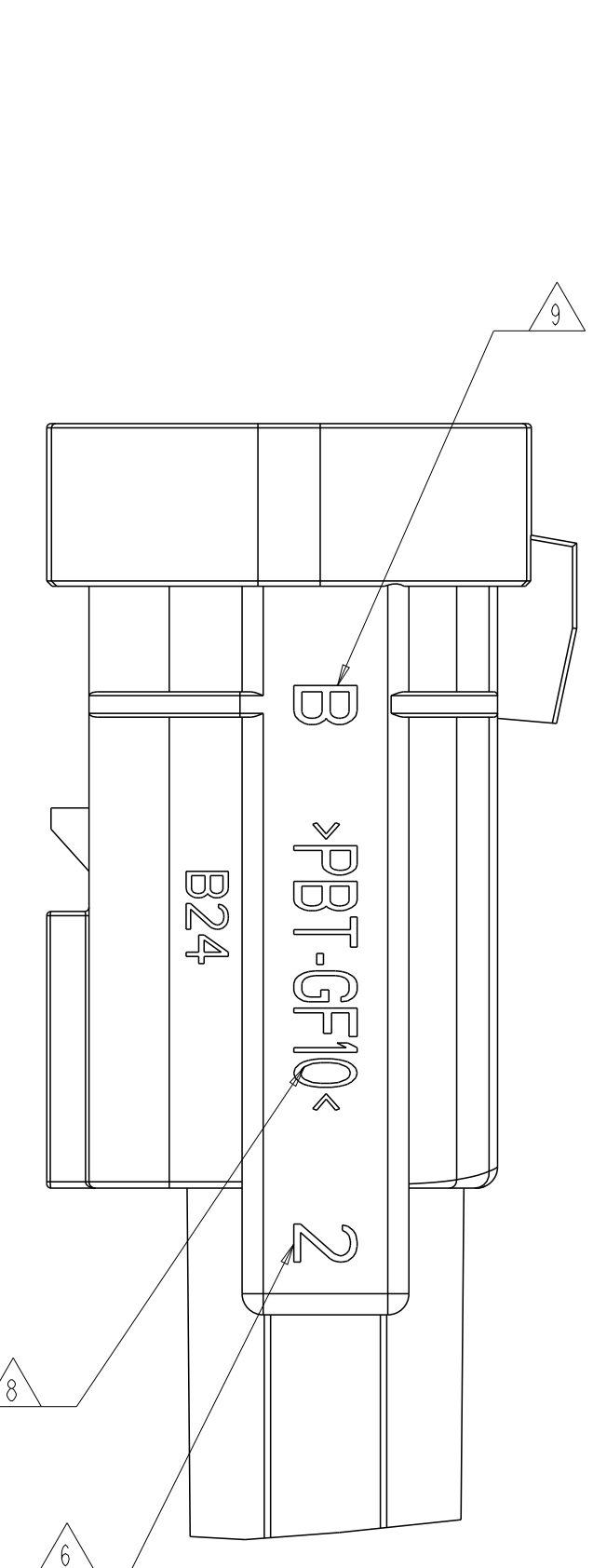
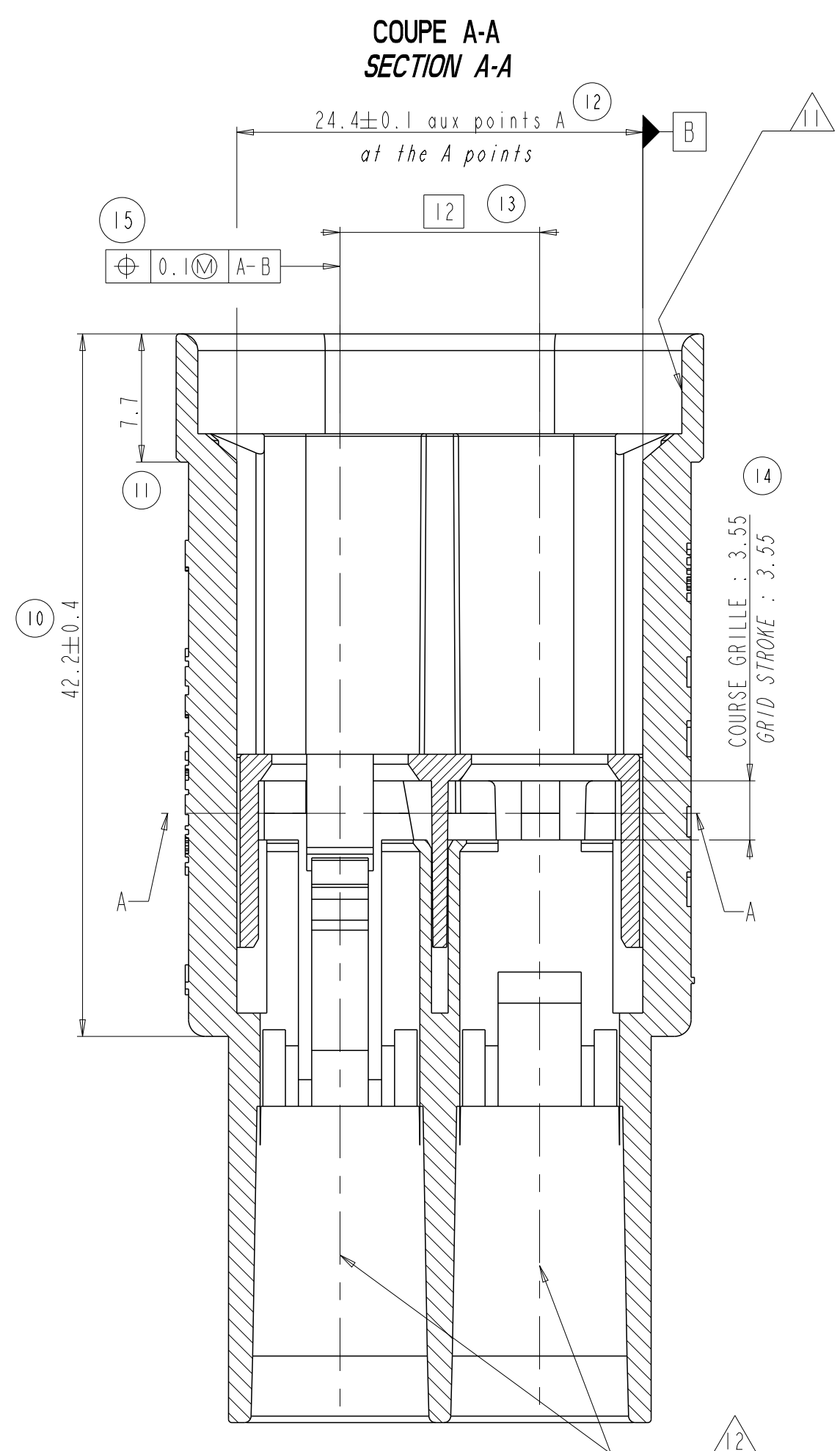
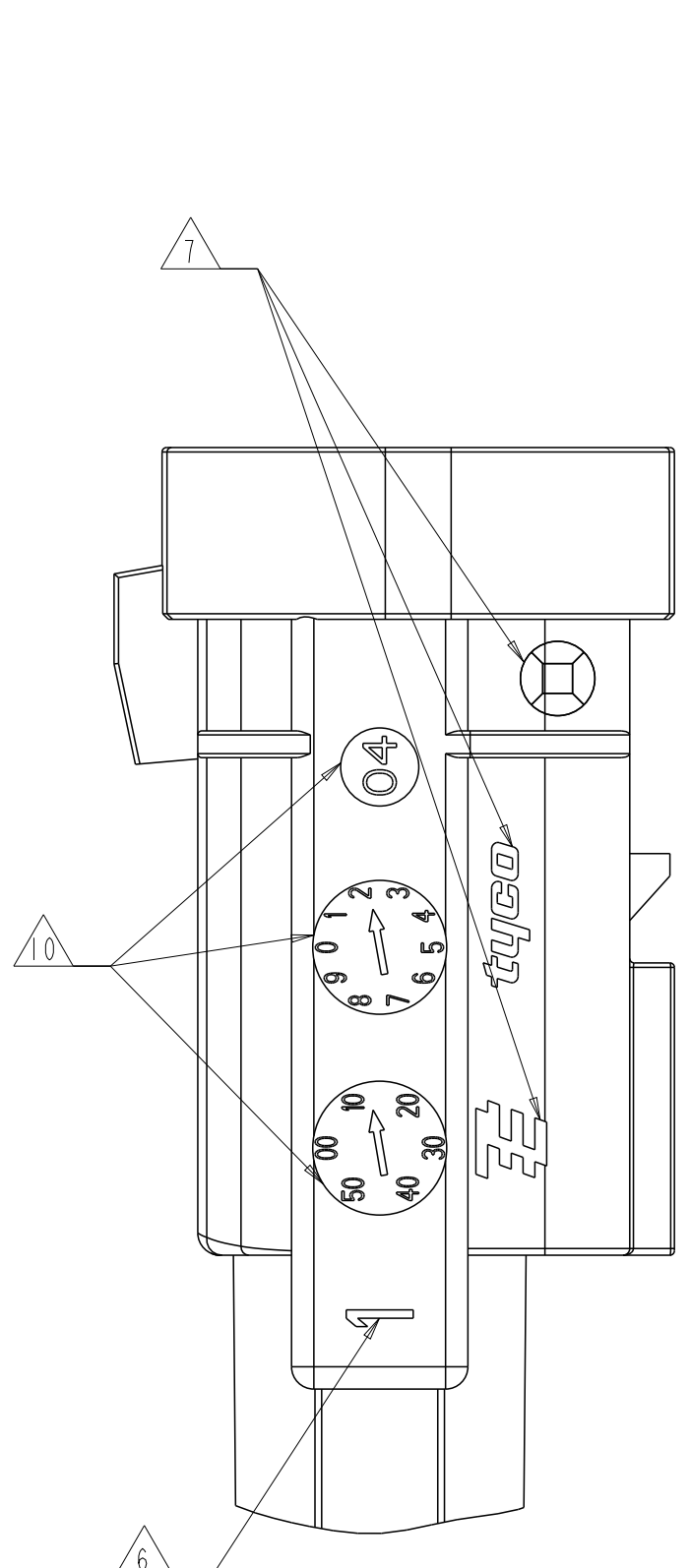

Rep	Qté	DESIGNATION Description	MATIERE Material	COULEUR Color
B	1	GRILLE DE DETECTION (DV) Detection Grid (DV)	PBT GF-10	JAUNE Yellow
A	1	PORTE-LANGUETTE Tab Housing	PBT GF-10	VOIR TABLEAU See table

REFERENCES TE ET CODAGES COULEURS ASSOCIES
TE PART NUMBERS AND ASSOCIATED CODING COLOR

1544334-1	1544334-2	1544334-3
7±0.1 (40)	3.5±0.05 (41)	3.5±0.05 (42)
NOIR / BLACK	BLEU / BLUE	GRIS / GREY

NOTE / NOTA

N° / Nr	DESIGNATION	DESCRIPTION
1	DISPOSITIF D'ACCROCHAGE	INTER-BOX LOCKING DEVICE
2	DEPOUILLES GENERALES COMPRISES DANS LES TOLERANCES	GENERALE SLOPS IN TOLERANCES
3	REPERE No MOULE 3 ET +	MOLD No 3 AND +, MARKING
4	REPERE No EMPREINTE MOULE	MOLD CAVITY No MARKING
5	GRILLE DE DETECTION LIVREE PRE-MONTEE	DETECTION GRID PRE-MOUNTED DELIVERED
6	REPERS ALVEOLES	CAVITIES MARKING
7	LOGO FOURNISSEUR EN RELIEF DE 0.2mm - PRONER SUR MOULE No 1 - TE SUR MOULE No 2 - TE SUR MOULE No 3 ET + SUIVANT I.A. SPEC I-15995-1	SUPPLIER LOGO RAISED, HEIGHT 0.2mm - PRONER ON MOLD No 1 - TE ON MOLD No 2 - TE ON MOLD No 3 AND + ACCORDING SPEC I-15995-1
8	MARQUAGE MATIERE	MATERIAL DESIGNATION MARKING
9	INDICE MAJEUR DE MODIFICATION EN RELIEF DE 0.2mm	MAJOR MODIFICATION CODE RAISED, HEIGHT 0.2mm
10	3 DATEURS : SEMAINES/ANNEES EN RELIEF DE 0.2mm	3 DATE CODE : WEEK/YEAR, RAISED, HEIGHT 0.2mm
11	ZONE D'ETANCHEITE POLIE, SANS BAVURE, MARQUEE OU MANQUEE MATIERE	POLISHED SEAL LOCATION WITHOUT FLASH OR PLASTIC DEFORMATION
12	ALVEOLES PLAN TE N° : 1544995 PLAN PSA STE N° : 9641756399	TE CAVITIES DRAWING N° : 1544995 PSA CAVITIES STE N° : 9641756399
13	CDC CONNECTIQUE PSA : No 9629966099	PSA SPECIFICATION : No 9629966099
14	PLAN D'INTERFACE TE No 1544681 PSA STE No 9638276999	INTERFACE DRAWING TE No 1544681 PSA STE No 9638276999
15	CAHIER DE PRECONISATIONS: TE No 411-15697 PSA STE No 9641781799	INSTRUCTION SHEET: TE No 411-15697 PSA STE No 9641781799

CARACTERISTIQUES MECANQUES PRINCIPALES
MAINES MECHANICAL SPECIFICATIONS

VALEURS RESULTS	
EFFORT D'INSERTION LANGUETTE / ALVEOLE (AVEC JOINT) : F < 35N TAB / CAVITY MATING FORCE (WITH SEAL) : F < 35N	27 N MAXI 27 N MAXI
EFFORT DE FERMETURE DU DV : 20N<F<40N SECONDARY-LOCK CLOSING FORCE : 20N<F<40N	39 N MAXI 39 N MAXI
EFFORT D'ACCROUPEMENT PC/PL : F < 80N REC HOUSING / TAB HOUSING CONNECTION FORCE : F < 80N	73 N MAXI 73 N MAXI

REFERENCES TE POUR CABLEURS
TE PART NUMBERS FOR WIRING MANUFACTURER

COMPONENTS COMPONENTS	REFERENCES PART NUMBERS	MATIERE MATERIAL	COULEUR COLOR
Langulette / Tab 8mm NGI Section 3 à 6 mm ² Wire section 3 to 6 mm ²	1544332-1	Laiton pré-étamé Pre-finned brass	/
Langulette / Tab 8mm NGI Section 7 à 10 mm ² Wire section 7 to 10 mm ²	1544333-1	Laiton pré-étamé Pre-finned brass	/
Joint unifié à sertir Single wire seal Section 3 à 6 mm ² Wire section 3 to 6 mm ²	1544316-1	Silicone 50sh A autolubrifié Silicone 50sh A self-lubricated	VERT Green
Joint unifié à sertir Single wire seal Section 7 à 10 mm ² Wire section 7 to 10 mm ²	1544316-2	Silicone 50sh A autolubrifié Silicone 50sh A self-lubricated	ORANGE Orange
Bouchon Bundle	1544316-3	Silicone 50sh A non-lubrifié Silicone 50sh A no-lubricated	BLANC White

THIS DRAWING IS A CONTROLLED DOCUMENT.
 CE PLAN EST UN DOCUMENT CONTROLÉ PAR AND INCORPORATED.
 ALL EDITIONS OF THIS DRAWING, INCLUDING REVISIONS, REMAIN THE PROPERTY OF AND AND MUST BE KEPT IN THE ORIGINAL FORM.

TE Connectivity

PORTE-LANGUETTES 2V 8mm NGI ETANCHE
 2 WAY SEALED 8mm NGI TAB HOUSING

1544334

00779

14 gr

1.4

3.00

1

F