

THIS DRAWING IS UNPUBLISHED
 RELEASED FOR PUBLICATION
 2015
 © COPYRIGHT 2015 BY TE CONNECTIVITY ALL RIGHTS RESERVED.

LOC	DIST	REVISIONS			
P	LTR	DESCRIPTION	DATE	DWN	APVD
-	-	NC	NEW RELEASE PE E.O. PI7348	26MAR2015	- RDR
-	-	A	REVISED PE E.O. PI9407	20NOV2006	- RDR
-	-	AI	REVISED PER ECO-15-005844	16APR2015	PV DM

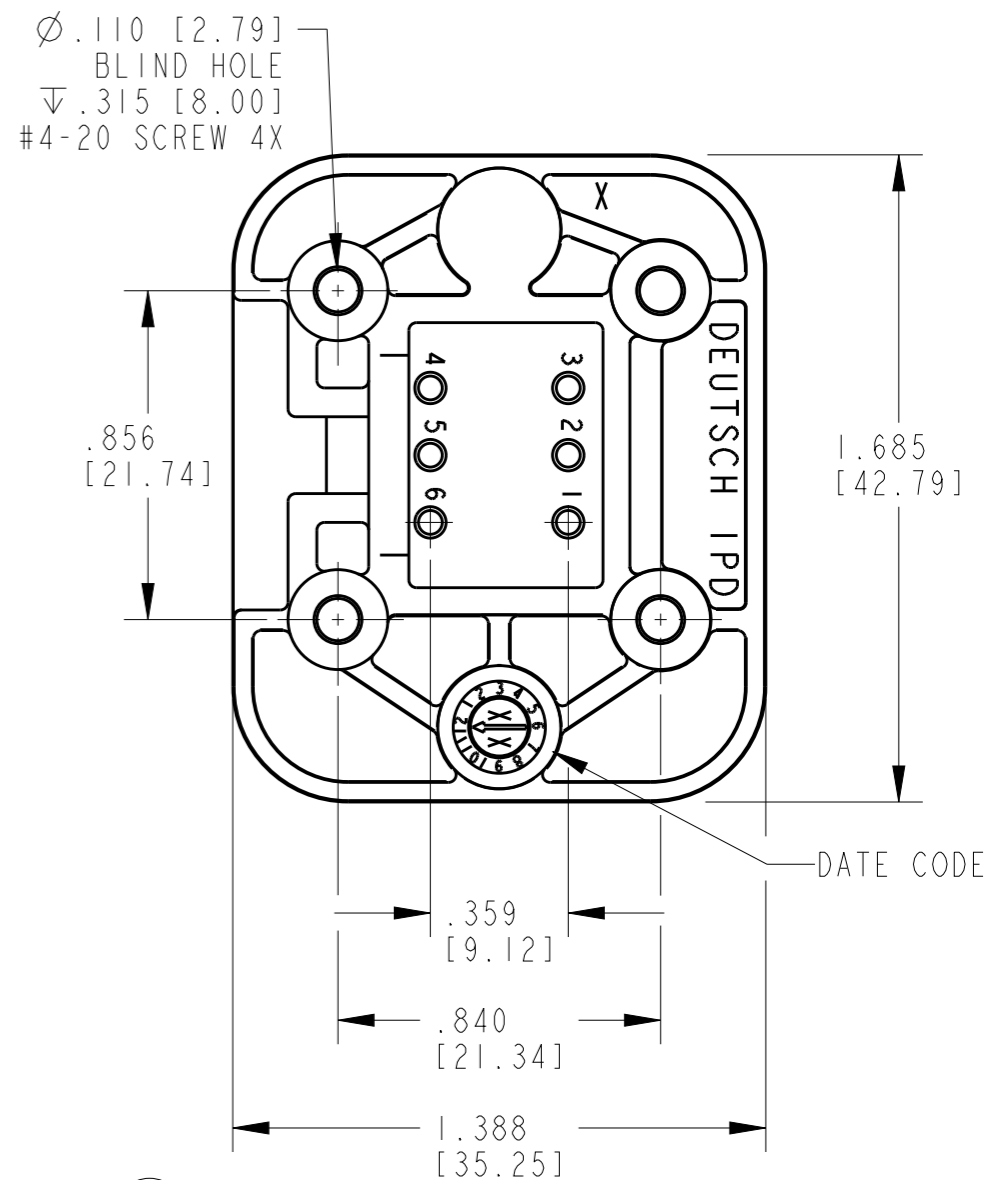
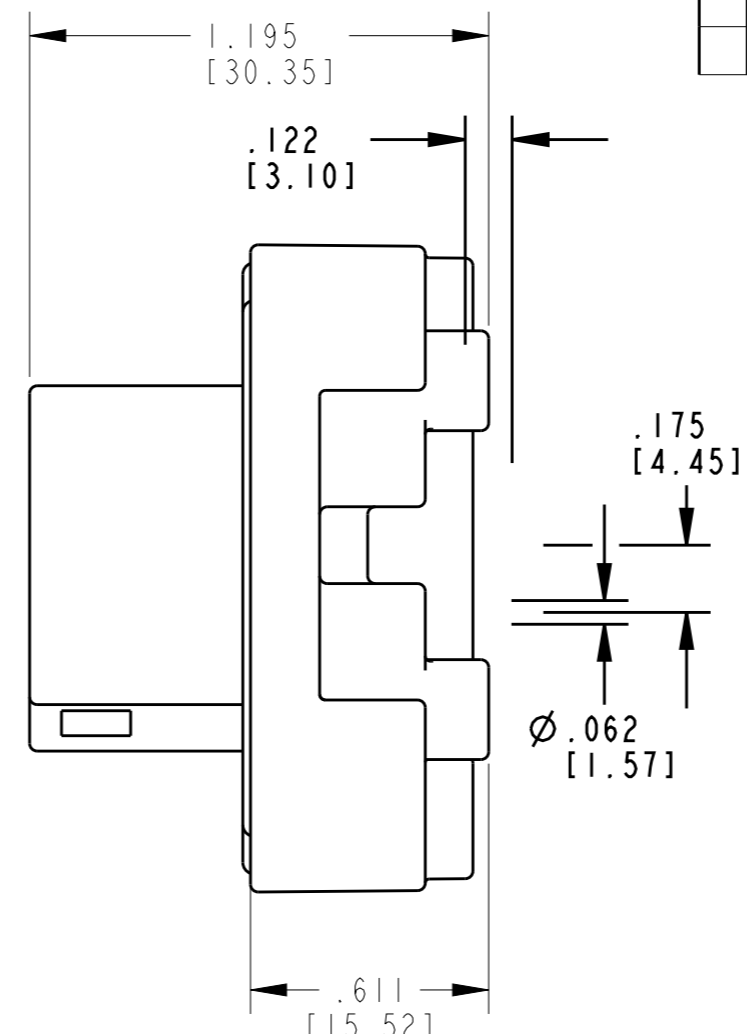
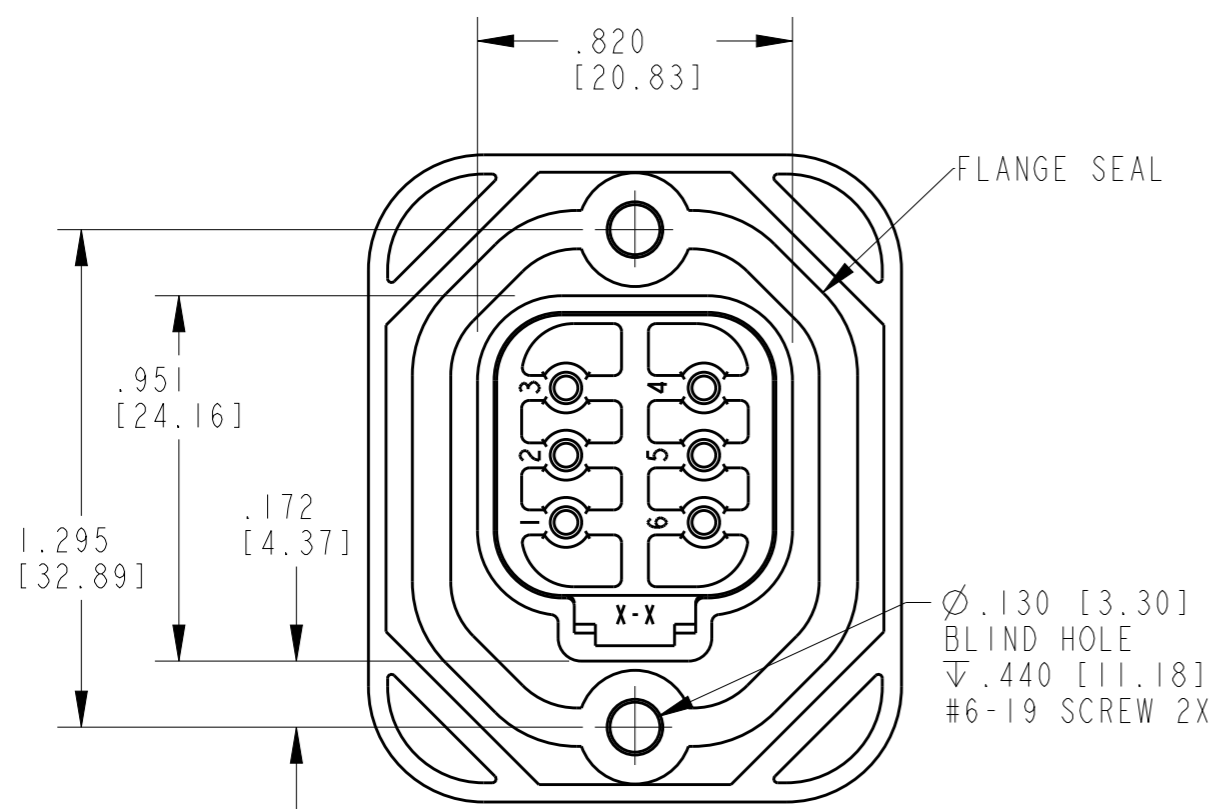

- 6. MOUNTING SCREW TORQUE VALUES ARE AS FOLLOWS:
 #6-19 SCREWS: 13±2.0 IN-LB [1.47±.23 N-M].
 #4-20 SCREWS: 8±2.0 IN-LB [.90±.23 N-M].
 VALUES VALID FOR PLASTITE 48 SCREWS ONLY.
- 5. RECOMMENDED MOUNTING SCREWS (NOT INCLUDED): CAMCAR PLASTITE 48.
- 4. THIS RECEPTACLE MATES WITH DT06-6S-XXXX PLUG (XXXX = ALL MODIFICATIONS.)

- (AI) 3. CONTACT PLATING- MATING SIDE: GOLD; PCB SIDE: TIN
- (AI) 2. MATERIAL:
 SHELL; PA GF-30 (GRAY)
 SEAL: SILICONE (ORANGE - RED).
 PIN CONTACT: COPPER ALLOY

- (AI) 1. DIMENSION TOLERANCE: ±.025 [.64]
 PANEL CUTOUT ±.010 [.25].
 PIN LOCATION: ±.005 [.13]
 MOUNTING HOLE LOCATION: ±.010 [.13]

NOTES:

(AI)	TCPN	ALIAS PART NUMBER
	DT15-6P-G003	DT15-6P-G003

THIS DRAWING IS A CONTROLLED DOCUMENT.		DWN P. BURKE 21SEP2001		TE Connectivity	
DIMENSIONS: INCHES [mm]		CHK B. BYFORD 17NOV2006			
		TOLERANCES UNLESS OTHERWISE SPECIFIED:		NAME PCB MOUNT RECEPTACLE 6 PINS G003 MOD DT SERIES	
		0 PLC ±- 1 PLC ±- 2 PLC ±- 3 PLC ±- 4 PLC ±- ANGLES ±0°30'0"		PRODUCT SPEC 108-151009	
MATERIAL		FINISH		APPLICATION SPEC -	
(AI) 2				SIZE A3	
				CAGE CODE 4AFU8	
				DRAWING NO ©-DT15-6P-G003	
				RESTRICTED TO -	
				WEIGHT 21 g	
				SCALE 2:1	
				SHEET 1 OF 2	
				REV AI	
				Customer Drawing	

THIS DRAWING IS UNPUBLISHED
 RELEASED FOR PUBLICATION 2015
 © COPYRIGHT 2015 BY TE CONNECTIVITY ALL RIGHTS RESERVED.

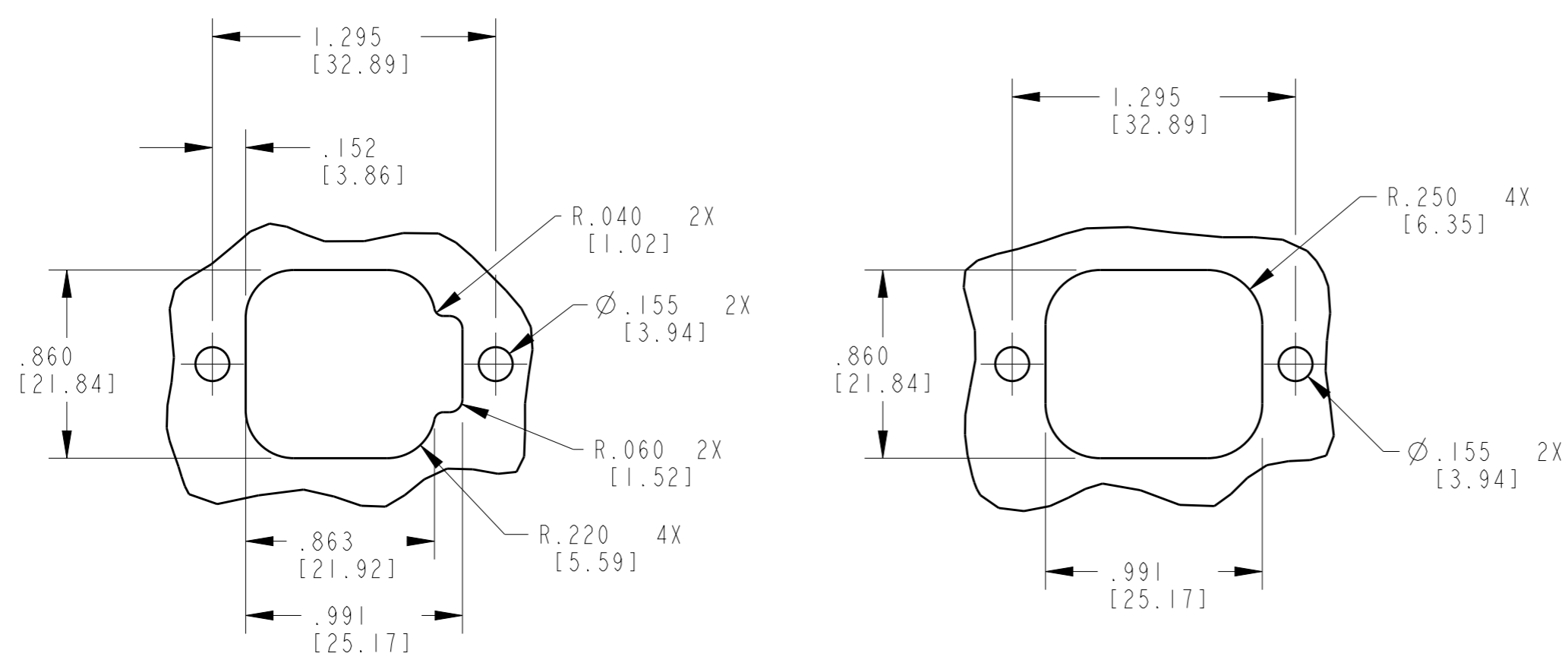

LOC		DIST		REVISIONS			
P	LTR	DESCRIPTION	DATE	DWN	APVD		
-	-	SEE SHEET 1	-	-	-		

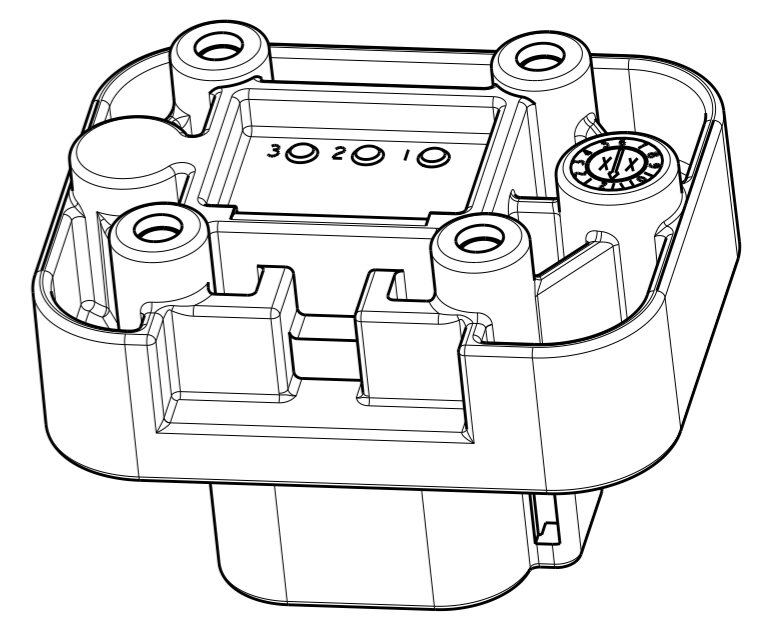

RECOMMENDED PANEL CUTOUTS



3D VIEW

THIS DRAWING IS A CONTROLLED DOCUMENT.		DWN P. BURKE 21SEP2001	 TE Connectivity	
DIMENSIONS: INCHES [mm]		CHK B. BYFORD 17NOV2006		
TOLERANCES UNLESS OTHERWISE SPECIFIED:		APVD S. BEARD 17NOV2006	NAME PCB MOUNT RECEPTACLE 6 PINS G003 MOD DT SERIES	
0 PLC ±- 1 PLC ±- 2 PLC ±- 3 PLC ±- 4 PLC ±- ANGLES ±0° 30' 0"		PRODUCT SPEC 108-151009	RESTRICTED TO	
MATERIAL		APPLICATION SPEC -	SIZE A3	CAGE CODE 4AFU8
FINISH -		WEIGHT 21 g	DRAWING NO G-DT15-6P-G003	
		Customer Drawing	SCALE 2:1	SHEET 2 OF 2
			REV A1	