

THIS DRAWING IS UNPUBLISHED. RELEASED FOR PUBLICATION
 © COPYRIGHT - TE Connectivity ALL RIGHTS RESERVED.

REVISIONS					
P	LTR	DESCRIPTION	DATE	DWN	APVD
B		REVISED PER ECR-19-007233	09MAY2019	BDA	SV

- 1 CONTINUOUS STRIP ON REELS WITH TERMINALS LOCATED ON 10.41±0.08 [.410±.003] CENTERS.
- 2 SLOT ACCEPTS 0.91-1.15mm [#19-#17] AWG COPPER MAGNET WIRE. 2 WIRES OF THE SAME SIZE MAX PER SLOT.
- 3 CONTACT LEAF ACCEPTS 0.81[.032] THICK POKE-IN TAB, (REFERENCE TAB DRAWING 1217324-1).

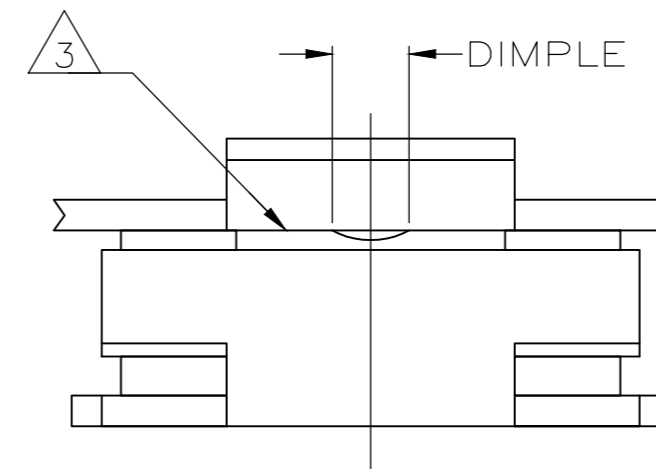
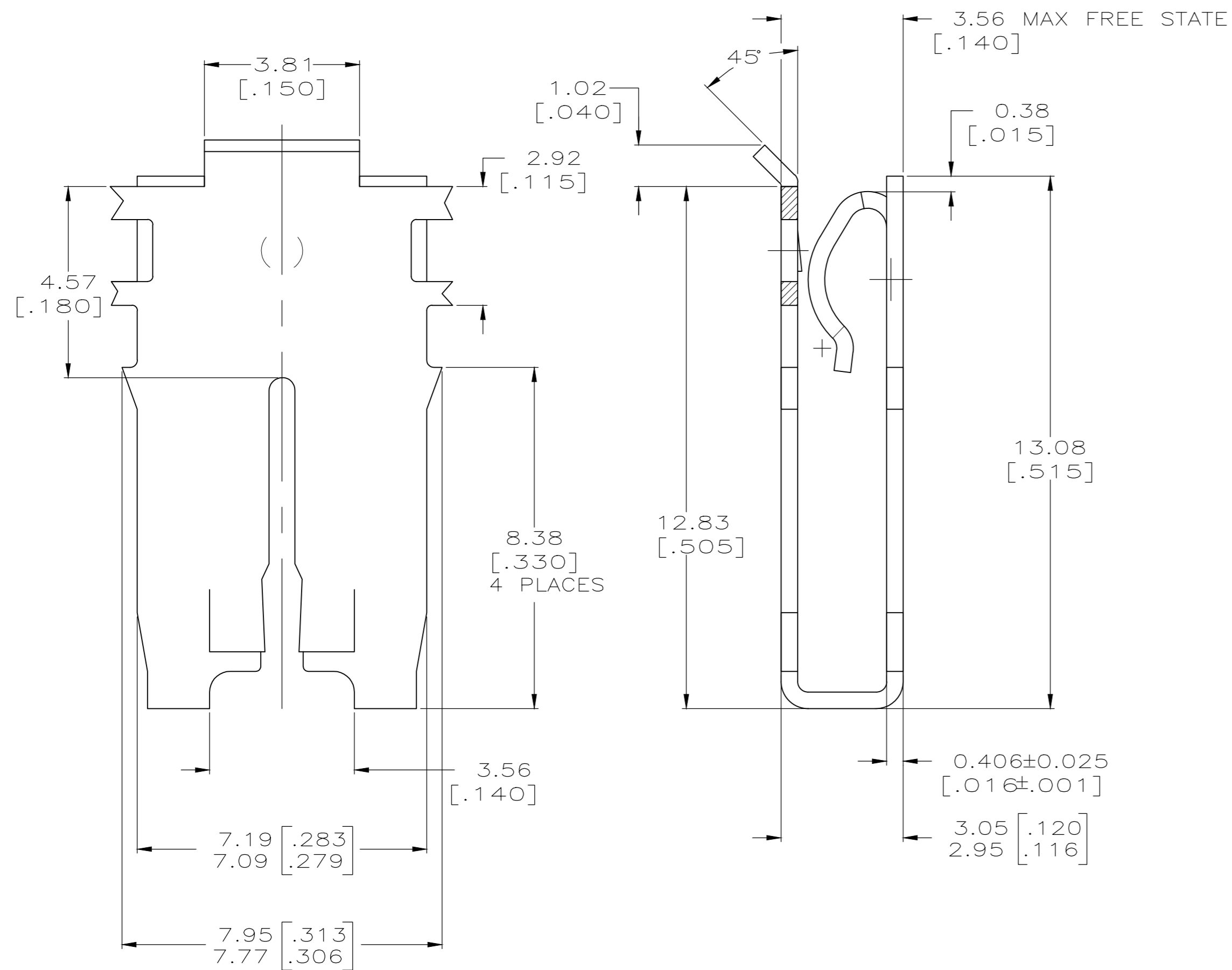

0.25 MAX CUT-OFF TABS [.010]

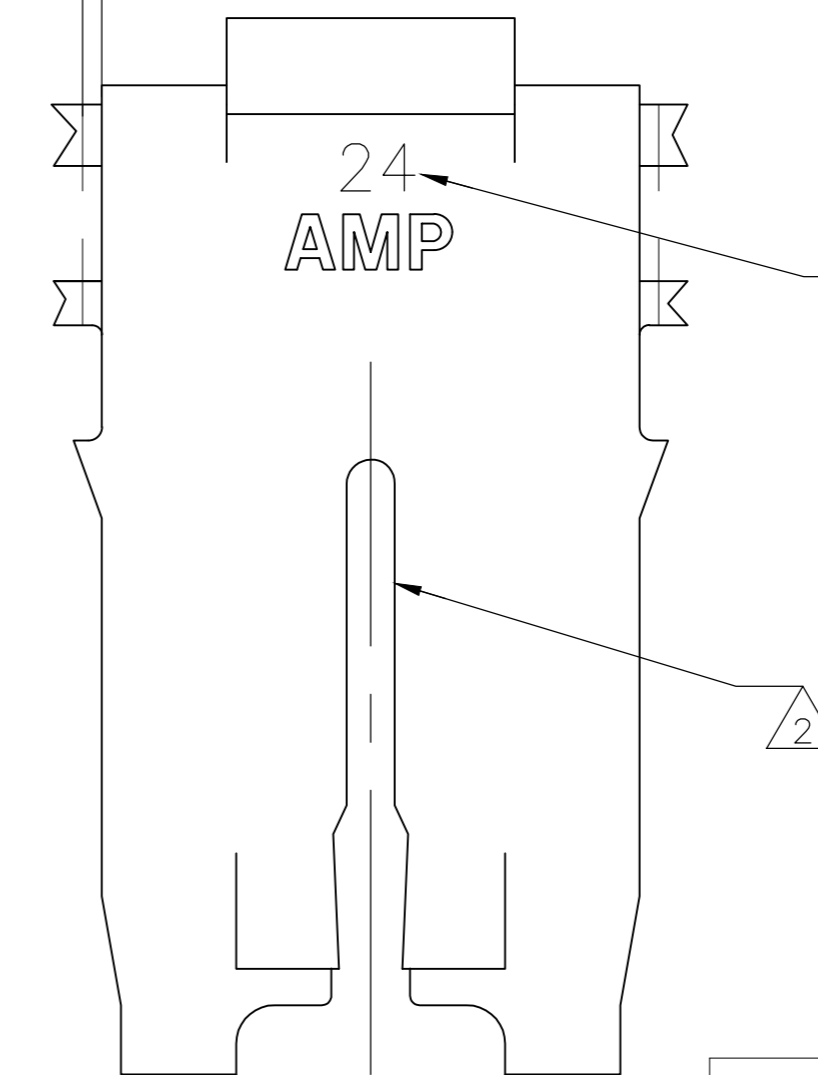

NICKEL	COPPER ALLOY	1217068-2
0.002032[.000080] MIN TIN OVER NICKEL	4M BRASS	1217068-1
FINISH	MATERIAL	PART NUMBER

THIS DRAWING IS A CONTROLLED DOCUMENT.		DWN RAGHAVENDRA 04FEB09		
DIMENSIONS: mm [INCHES]		CHK K. A. RANDOLPH 04FEB09		
TOLERANCES UNLESS OTHERWISE SPECIFIED:		APVD K. A. RANDOLPH 04FEB09	NAME	
0 PLC ± -	1 PLC ± -	PRODUCT SPEC 108-2053	SPECIAL LEAF CONTACT, 500 SERIES, MAG-MATE TM	
2 PLC ± 0.25[.010]	3 PLC ± -	APPLICATION SPEC 114-2066	SIZE A2	CAGE CODE 00779
4 PLC ± -	ANGLES ± -	WEIGHT	DRAWING NO C=1217068	RESTRICTED TO -
MATERIAL -	FINISH -	CUSTOMER DRAWING	SCALE 10:1	SHEET 1 of 1
			REV B	