

P	LTR	DESCRIPTION	DATE	DWN	APVD
	B1	ECO-20-004274	26MAR2021	RK	DR
	C	REVISED PER ECR-23-165796	28FEB2023	LP	DSC

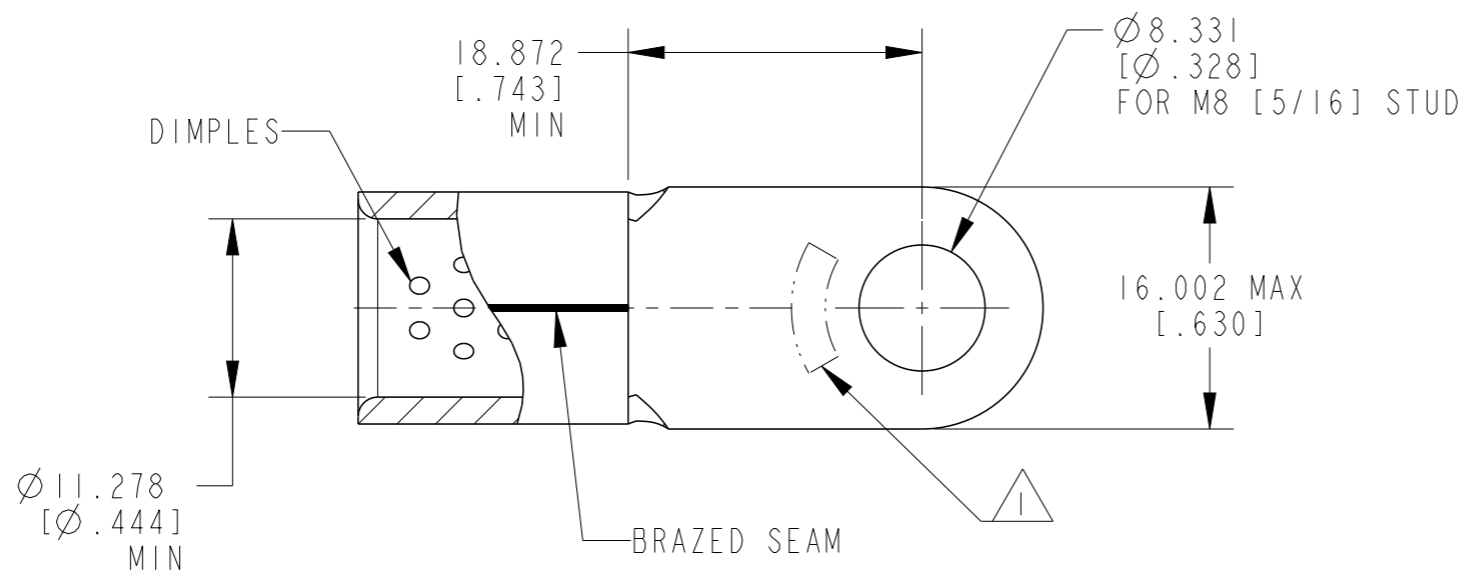

AMP
WIRE RANGE
1/0 AWG
SOLID OR STRANDED

- 1 STAMP: AMP 1/0 W* APPROX AS SHOWN.
- 2 MATERIAL: COPPER PER ASTM B152.
- 3 FINISH: NICKEL PLATE 0.00762[.000300] MIN EXT THK PER SAE AMS-QQ-N-290
- 4. MATERIAL THK: 1.778±0.051[.070±.002]

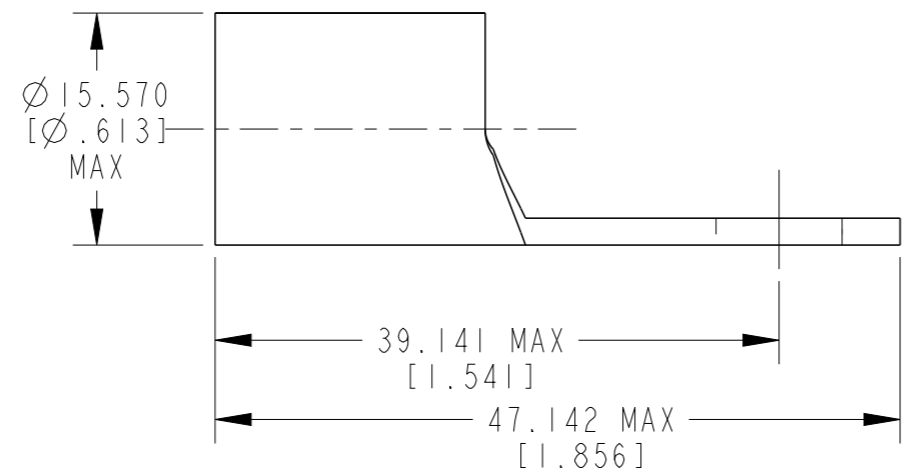

50	LOOSE PIECE	132066-2
QTY	PACKAGE TYPE	PART NUMBER

AMP INCORPORATED CUSTOMER SERVICE SYSTEMS		
FOR ADDITIONAL PRODUCT INFORMATION OR COPIES OF DRAWINGS AND TECHNICAL DOCUMENTS	PRODUCT INFORMATION CENTER 1-800-522-6752	MAX. RECOMMENDED OPERATING TEMPERATURE: 343°C [649°F]
FOR APPLICATION TOOLING INFORMATION	TOOLING ASSISTANCE CENTER 1-800-722-1111	VOLTAGE RATING: NOT APPLICABLE
FOR ORDER ENTRY	1-800-526-5142	WIRE CROSS SECTIONAL AREA RANGE: 42.4-60.6mm ² [83,700-119,500] CIR MILS SOLID OR STRANDED

THIS DRAWING IS A CONTROLLED DOCUMENT.	
DIMENSIONS: mm [INCHES]	TOLERANCES UNLESS OTHERWISE SPECIFIED:
	0 PLC ±-
	1 PLC ±-
	2 PLC ±-
	3 PLC ±0.127 (.005)
	4 PLC ±-
	ANGLES ±-
MATERIAL	FINISH
2	3

DWN	06APR2020
RAGHAVENDRA.K	
CHK	06APR2020
DANIEL.R	
APVD	06APR2020
DANIEL.R	
PRODUCT SPEC	108-32046
APPLICATION SPEC	114-2162
WEIGHT	-
CUSTOMER DRAWING	

TE Connectivity		NAME	
		TERMINAL, RING TONGUE, STRATO-THERM HEAT RESISTANT, WIRE SIZE: 1/0 AWG	
SIZE	CAGE CODE	DRAWING NO	RESTRICTED TO
A3	00779	C-132066	-
SCALE		SHEET	REV
2:1		1 OF 1	C