2CH PWM DC/DC CONTROLLER

NO.EA-086-160126

OUTLINE

The R1282D002A is a CMOS-based 2-channel PWM Step-up (as Channel 1)/Step-down (as Channel 2) DC/DC converter controller.

The R1282D002A consists of an oscillator, a PWM control circuit, a reference voltage unit, an error amplifier, a reference current unit, a protection circuit, and an under voltage lockout (UVLO) circuit. A high efficiency Step-up/Step-down DC/DC converter can be composed of this IC with inductors, diodes, power MOSFETs, resistors, and capacitors. Each output voltage and maximum duty cycle can be adjustable with external resistors, while soft-start time can be adjustable with external capacitors and resistors.

As for a protection circuit, if Maximum duty cycle of either Step-up DC/DC converter side or Step-down DC/DC converter side is continued for a certain time, the R1280D002A latches both external drivers with their off state by its Latch-type protection circuit. Delay time for protection is internally fixed typically at 100ms. To release the protection circuit, restart with power-on (Voltage supplier is equal or less than UVLO detector threshold level).

FEATURES

- Input Voltage Range2.5V to 5.5V
- Built-in Latch-type Protection Function by monitoring duty cycle (Fixed Delay Time Typ. 100ms)
- Oscillator Frequency 700kHz
- High Accuracy Voltage Reference±1.5%
- U.V.L.O. Threshold..... Typ. 2.2V (Hysteresis: Typ. 0.2V)
- Small Packagethin SON-10 (package thickness Max. 0.9mm)

APPLICATIONS

- Constant Voltage Power Source for Portable Equipment.
- Constant Voltage Power Source for LCD and CCD.

BLOCK DIAGRAM

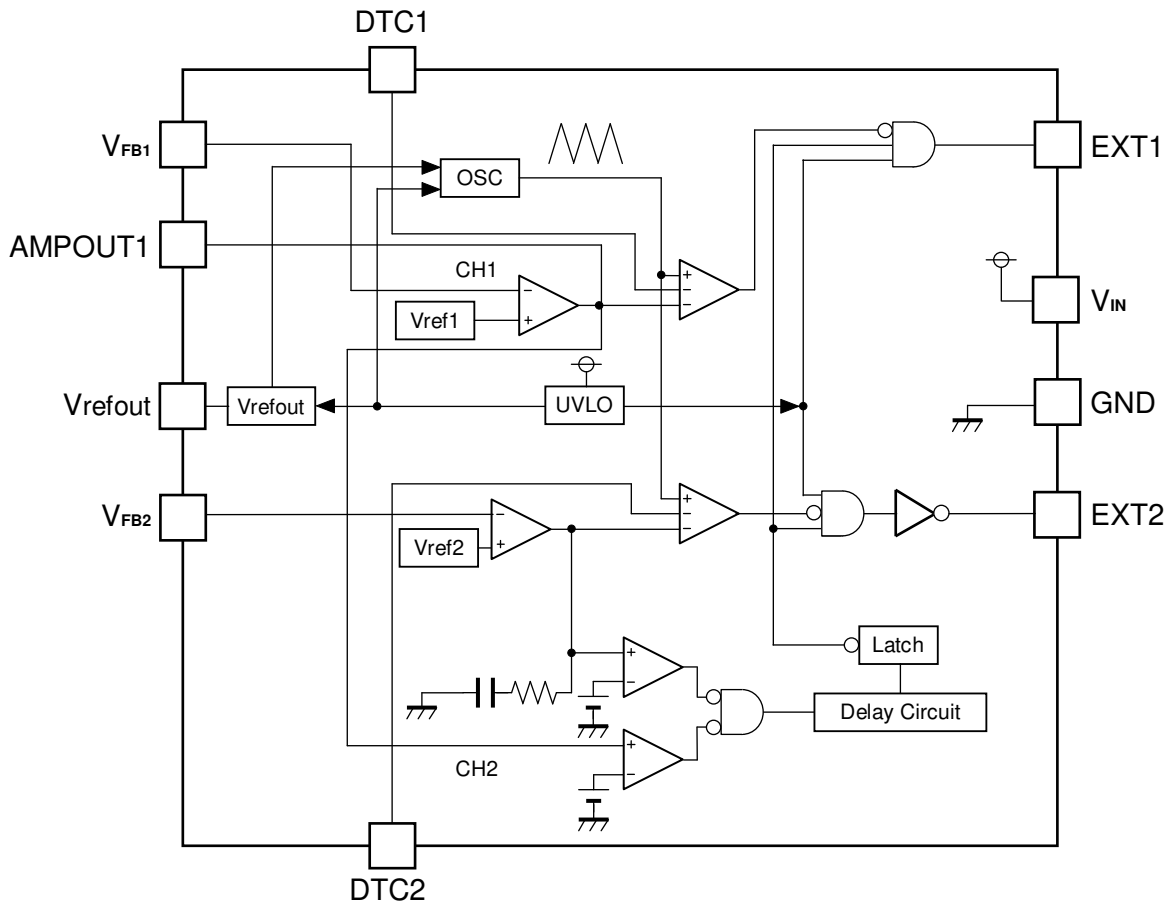

SELECTION GUIDE

The selection can be made with designating the part number as shown below;

Product Name	Package	Quantity per Reel	Pb Free	Halogen Free
R1282D002x-TR-FE	SON-10	3,000 pcs	Yes	Yes

x: Designation of Mask Option
 A version: fosc=700kHz, with External Phase Compensation for Channel 1

PIN CONFIGURATION

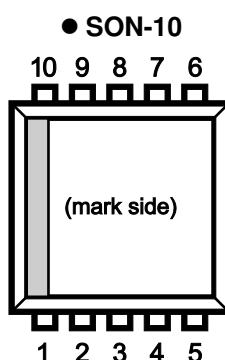

PIN DESCRIPTION

Pin No	Symbol	Description
1	EXT1	External Transistor of Channel 1 Drive Pin (CMOS Output)
2	GND	Ground Pin
3	AMPOUT1	Amplifier Output Pin of Channel 1
4	DTC1	Maximum Duty Cycle of Channel 1 Setting Pin
5	V _{FB1}	Feedback pin of Channel 1
6	V _{FB2}	Feedback pin of Channel 2
7	DTC2	Maximum Duty Cycle of Channel 2 Setting Pin
8	V _{refout}	Reference Output Pin
9	V _{IN}	Voltage Supply Pin of the IC
10	EXT2	External Transistor of Channel 2 Drive Pin (CMOS Output)

ABSOLUTE MAXIMUM RATINGS

Symbol	Item	Rating	Unit
V _{IN}	V _{IN} Pin Voltage	6.5	V
V _{EXT1,2}	V _{EXT1,2} Pin Output Voltage	-0.3~V _{IN} +0.3	V
V _{AMPOUT1}	AMPOUT1 Pin Voltage	-0.3~V _{IN} +0.3	V
V _{DTC1,2}	DTC1,2 Pin Voltage	-0.3~V _{IN} +0.3	V
V _{refout}	V _{REFOUT} Pin Voltage	-0.3~V _{IN} +0.3	V
V _{FB1,2}	V _{FB1} , V _{FB2} Pin Voltage	-0.3~V _{IN} +0.3	V
I _{EXT1,2}	EXT1,2 Pin Output Current	±50	mA
P _D	Power Dissipation	250	mW
T _{opt}	Operating Temperature Range	-40 to +85	°C
T _{stg}	Storage Temperature Range	-55 to +125	°C

ELECTRICAL CHARACTERISTICS

T_{opt}=25°C

Symbol	Item	Conditions	Min.	Typ.	Max.	Unit
V _{IN}	Operating Input Voltage		2.5		5.5	V
V _{REFOUT}	V _{REFOUT} Voltage Tolerance	V _{IN} =3.3V, I _{OUT} =1mA	1.478	1.500	1.522	V
I _{ROUT}	V _{REFOUT} Output Current	V _{IN} =3.3V	20			mA
ΔV _{REFOUT} /ΔV _{IN}	V _{REFOUT} Line Regulation	2.5V ≤ V _{IN} ≤ 5.5V		2	6	mV
ΔV _{REFOUT} /ΔI _{OUT}	V _{REFOUT} Load Regulation	1mA ≤ I _{ROUT} ≤ 10mA V _{IN} =3.3V		6	12	mV
I _{LIM}	V _{REFOUT} Short Current Limit	V _{IN} =3.3V, V _{REFOUT} =0V		25		mA
ΔV _{REFOUT} /ΔT	V _{REFOUT} Voltage Temperature Coefficient	-40°C ≤ T _{opt} ≤ 85°C		±150		ppm/°C
V _{FB1}	V _{FB1} Voltage	V _{IN} =3.3V	0.985	1.000	1.015	V
ΔV _{FB1} /ΔT	V _{FB1} Voltage Temperature Coefficient	-40°C ≤ T _{opt} ≤ 85°C		±150		ppm/°C
ΔV _{FB2} /ΔT	V _{FB2} Voltage Temperature Coefficient	-40°C ≤ T _{opt} ≤ 85°C		±150		ppm/°C
I _{VFB1,2}	V _{FB1,2} Input Current	V _{IN} =5.5V, V _{FB1} or V _{FB2} =0V or 5.5V	-0.1		0.1	μA
f _{OSC}	Oscillator Frequency	EXT1,2 Pins at no load, V _{IN} =3.3V	595	700	805	kHz
I _{DD1}	Supply Current	V _{IN} =5.5V, EXT1,2 pins at no load		1.4	3.0	mA
R _{EXTH1}	EXT1 "H" ON Resistance	V _{IN} =3.3V, I _{EXT} =-20mA		4.0	8.0	Ω
R _{EXTL1}	EXT1 "L" ON Resistance	V _{IN} =3.3V, I _{EXT} =20mA		2.7	5.0	Ω
R _{EXTH2}	EXT2 "H" ON Resistance	V _{IN} =3.3V, I _{EXT} =-20mA		4.0	8.0	Ω
R _{EXTL2}	EXT2 "L" ON Resistance	V _{IN} =3.3V, I _{EXT} =20mA		3.7	8.0	Ω
T _{DLY}	Delay Time for Protection	V _{IN} =3.3V, V _{FB1} =1.1V→0V	60	100	140	ms
V _{UVLOD}	UVLO Detector Threshold		2.10	2.20	2.35	V
V _{UVLO}	UVLO Released Voltage			V _{UVLOD} +0.20	2.48	V
V _{DTC10}	CH1 Duty=0%	V _{IN} =3.3V	0.1	0.2	0.3	V
V _{DTC1100}	CH1 Duty=100%	V _{IN} =3.3V	1.1	1.2	1.3	V
V _{DTC20}	CH2 Duty=0%	V _{IN} =3.3V	0.1	0.2	0.3	V
V _{DTC2100}	CH2 Duty=100%	V _{IN} =3.3V	1.1	1.2	1.3	V
A _{V1}	CH1 Open Loop Gain	V _{IN} =3.3V		110		dB
F _{T1}	CH1 Single Gain Frequency Band	V _{IN} =3.3V, A _{V1} =0dB		1.9		MHz
V _{ICR1}	CH1 Input Voltage Range	V _{IN} =3.3V		0.7 to V _{IN}		V
I _{AMPL}	CH1 Sink Current	V _{IN} =3.3V, V _{AMPOUT1} =1.0V, V _{FB1} =V _{FB1} + 0.1V	70	115		μA
I _{AMPH}	CH1 Source Current	V _{IN} =3.3V, V _{AMPOUT1} =1.0V, V _{FB1} =V _{FB1} - 0.1V		-1.4	-0.7	mA
A _{V2}	CH2 Open Loop Gain	V _{IN} =3.3V		60		dB
F _{T2}	CH2 Single Gain Frequency Band	V _{IN} =3.3V, A _{V2} =0dB		600		kHz
V _{ICR2}	CH2 Input Voltage Range	V _{IN} =3.3V		-0.2 to V _{IN} -1.3		V
V _{FB2}	CH2 Reference Voltage	V _{IN} =3.3V	0.985	1.000	1.015	V

Output Current and Selection of External Components

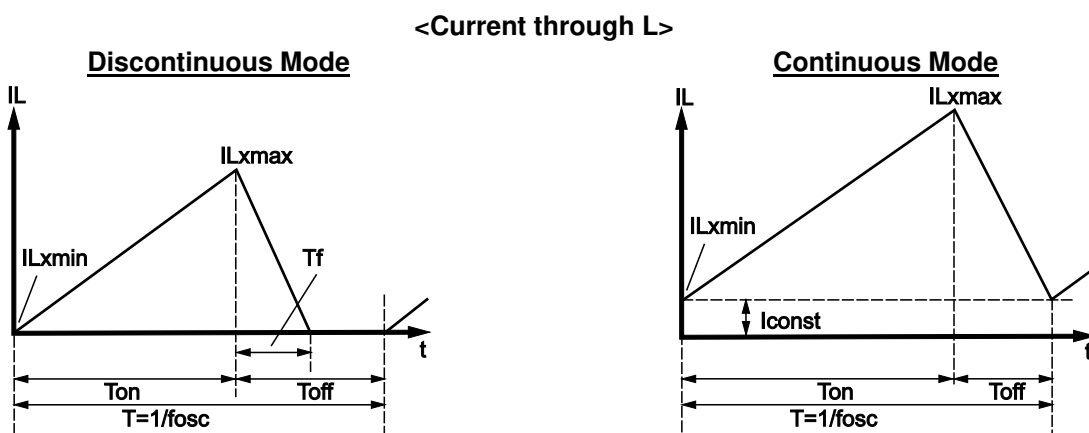
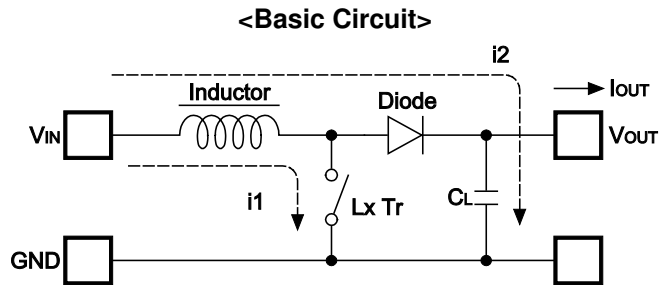

There are two modes, or discontinuous mode and continuous mode for the PWM step-up switching regulator depending on the continuous characteristic of inductor current.

During on time of the transistor, when the voltage added on to the inductor is described as V_{IN} , the current is $V_{IN} \times t/L$.

Therefore, the electric power, P_{ON} , which is supplied with input side, can be described as in next formula.

$$P_{ON} = \int_0^{T_{on}} V_{IN}^2 \times t/L dt \dots\dots\dots \text{Formula 1}$$

With the step-up circuit, electric power is supplied from power source also during off time. In this case, input current is described as $(V_{OUT}-V_{IN}) \times t/L$, therefore electric power, P_{OFF} is described as in next formula.

$$P_{OFF} = \int_0^{T_f} V_{IN} \times (V_{OUT} - V_{IN})t/L dt \dots\dots\dots \text{Formula 2}$$

In this formula, T_f means the time of which the energy saved in the inductance is being emitted. Thus average electric power, P_{AV} is described as in the next formula.

$$P_{AV} = 1/(T_{on} + T_{off}) \times \left\{ \int_0^{T_{on}} V_{IN}^2 \times t/L dt + \int_0^{T_f} V_{IN} \times (V_{OUT} - V_{IN})t/L dt \right\} \dots\dots\dots \text{Formula 3}$$

In PWM control, when $T_f = T_{off}$ is true, the inductor current becomes continuous, then the operation of switching regulator becomes continuous mode.

In the continuous mode, the deviation of the current is equal between on time and off time.

$$V_{IN} \times T_{on} / L = (V_{OUT} - V_{IN}) \times T_{off} / L \dots\dots\dots \text{Formula 4}$$

Further, the electric power, P_{AV} is equal to output electric power, $V_{OUT} \times I_{OUT}$, thus,

$$I_{OUT} = f_{OSC} \times V_{IN}^2 \times T_{on}^2 / \{2 \times L \times (V_{OUT} - V_{IN})\} = V_{IN}^2 \times T_{on} / (2 \times L \times V_{OUT}) \dots\dots\dots \text{Formula 5}$$

When I_{OUT} becomes more than $V_{IN} \times T_{on} \times T_{off} / (2 \times L \times (T_{on} + T_{off}))$, the current flows through the inductor, then the mode becomes continuous. The continuous current through the inductor is described as I_{const} , then,

$$I_{OUT} = f_{OSC} \times V_{IN}^2 \times T_{on}^2 / (2 \times L \times (V_{OUT} - V_{IN})) + V_{IN} \times I_{const} / V_{OUT} \dots\dots\dots \text{Formula 6}$$

In this moment, the peak current, I_{Lxmax} flowing through the inductor and the driver T_r is described as follows:

$$I_{Lxmax} = I_{const} + V_{IN} \times T_{on} / L \dots\dots\dots \text{Formula 7}$$

With the formula 4,6, and I_{Lxmax} is,

$$I_{Lxmax} = V_{OUT} / V_{IN} \times I_{OUT} + V_{IN} \times T_{on} / (2 \times L) \dots\dots\dots \text{Formula 8}$$

Therefore, peak current is more than I_{OUT} . Considering the value of I_{Lxmax} the condition of input and output, and external components should be selected.

In the formula 7, peak current I_{Lxmax} at discontinuous mode can be calculated. Put $I_{const} = 0$ in the formula.

The explanation above is based on the ideal calculation, and the loss caused by L_x switch and external components is not included. The actual maximum output current is between 50% and 80% of the calculation. Especially, when the I_{Lx} is large, or V_{IN} is low, the loss of V_{IN} is generated with the on resistance of the switch. As for V_{OUT} , V_f (as much as 0.3V) of the diode should be considered.

There are also two modes, or discontinuous mode and continuous mode for the PWM step-down switching regulator depending on the continuous characteristic of inductor current.

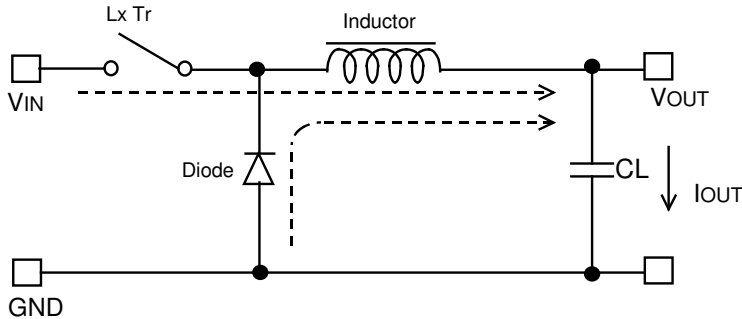

< Current through L >

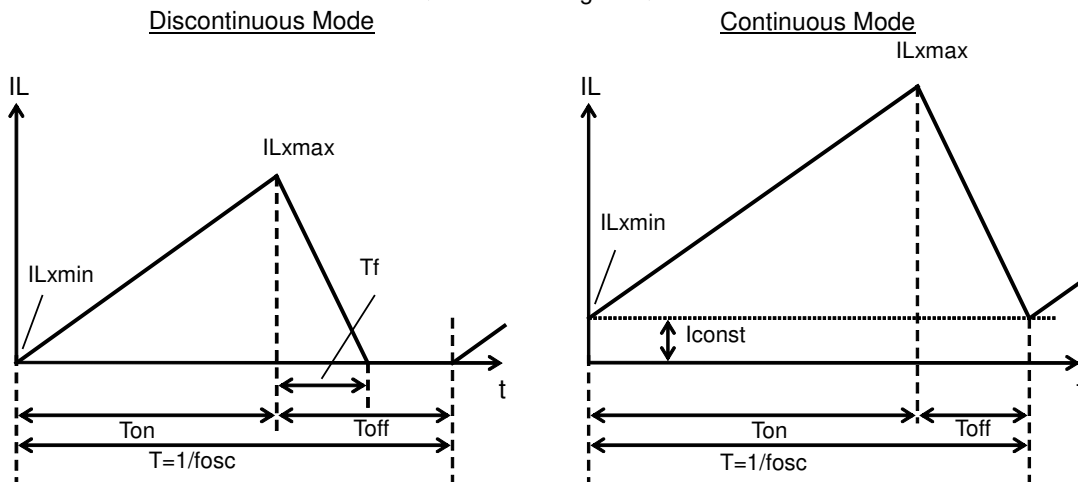

During on time of the transistor, when the voltage added on to the inductor is described as $V_{IN} - V_{OUT}$ the current is $(V_{IN} - V_{OUT}) \times t / L$.

Therefore, the electric power, P, which is supplied from the input side, can be described as in next formula.

$$P = \int_0^{T_{on}} V_{IN} \cdot (V_{IN} - V_{OUT}) \cdot t / L dt \dots\dots\dots \text{Formula 9}$$

Thus average electric power in one cycle, P_{AV} is described as in the next formula.

$$P_{AV} = 1 / (T_{on} + T_{off}) \int_0^{T_{on}} V_{IN} \cdot (V_{IN} - V_{OUT}) \cdot t / L dt = V_{IN} \cdot (V_{IN} - V_{OUT}) \cdot T_{on}^2 / (2 \cdot L \cdot (T_{on} + T_{off})) \dots \text{Formula 10}$$

This electric power P_{AV} equals to output electric power $V_{OUT} \times I_{OUT}$, thus,

$$I_{OUT} = V_{IN} / V_{OUT} \times (V_{IN} - V_{OUT}) \cdot T_{on}^2 / (2 \times L \times (T_{on} + T_{off})) \dots\dots\dots \text{Formula 11}$$

When I_{OUT} increases and the current flows through the inductor continuously, then the mode becomes continuous. In the continuous mode, the deviation of the current equals between T_{on} and T_{off} , therefore,

$$(V_{IN} - V_{OUT}) \times T_{on} / L = V_{OUT} \times T_{off} / L \dots\dots\dots \text{Formula 12}$$

In this moment, the current flowing continuously through L, is assumed as I_{const} , I_{OUT} is described as in the next formula:

$$I_{OUT} = I_{CONST} + V_{OUT} \times T_{off} / (2 \times L) \dots\dots\dots \text{Formula 13}$$

In this moment, the peak current, I_{Lxmax} flowing through the inductor and the driver T_r is described as follows:

$$I_{Lxmax} = I_{OUT} + V_{OUT} \times T_{off} / (2 \times L) \dots\dots\dots \text{Formula 14}$$

With the formula 12,13, I_{Lxmax} is,

$$T_{off} = (1 - V_{OUT} / V_{IN}) / f_{osc} \dots\dots\dots \text{Formula 15}$$

Therefore, peak current is more than I_{OUT} . Considering the value of I_{Lxmax} , the condition of input and output, and external components should be selected.

In the formula 14, peak current I_{Lxmax} at discontinuous mode can be calculated. Put $I_{const}=0$ in the formula.

The explanation above is based on the ideal calculation, and the loss caused by L_x switch and external components is not included.

TEST CIRCUITS

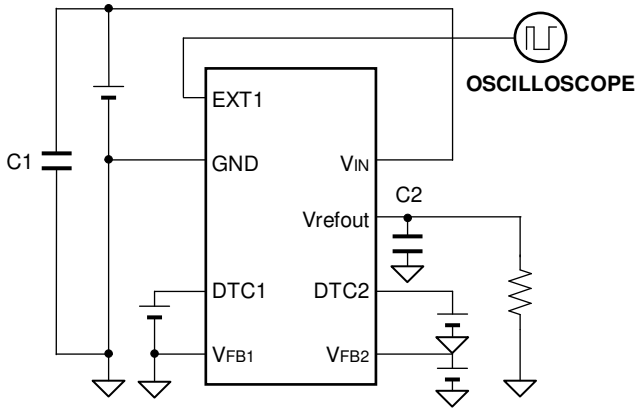

Test Circuit 1

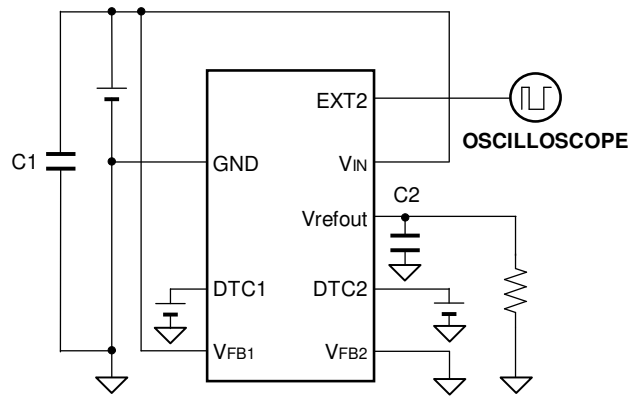

Test Circuit 2

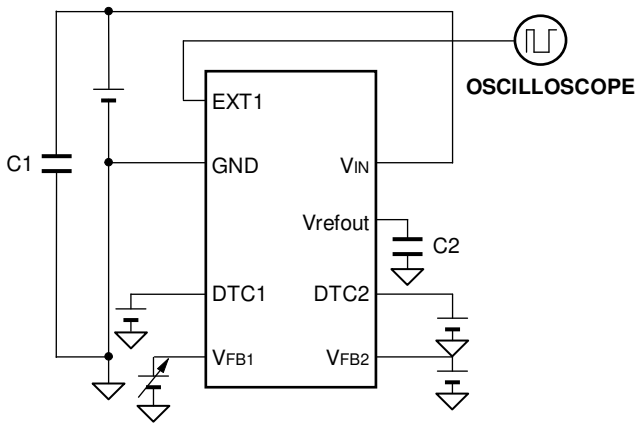

Test Circuit 3

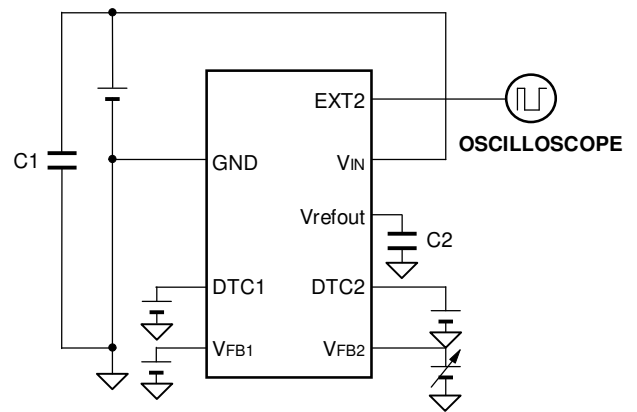

Test Circuit 4

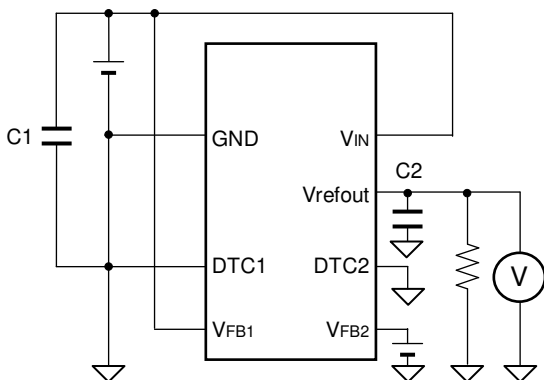

Test Circuit 5

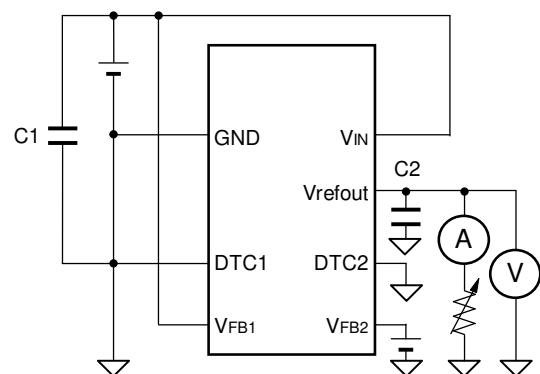

Test Circuit 6

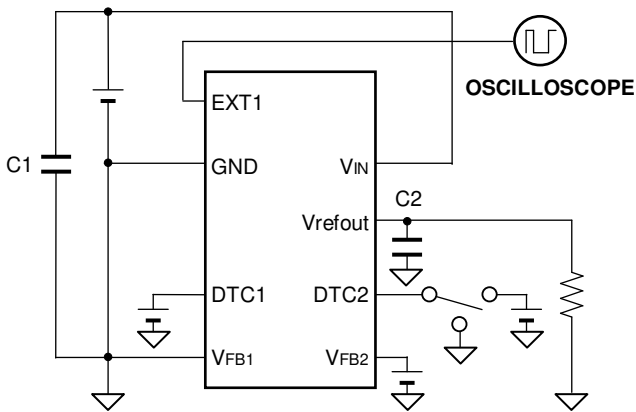

Test Circuit 7

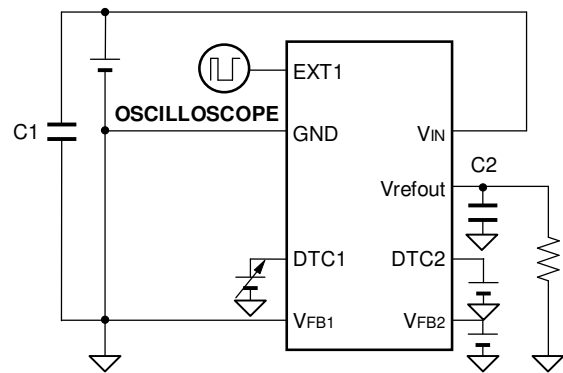

Test Circuit 8

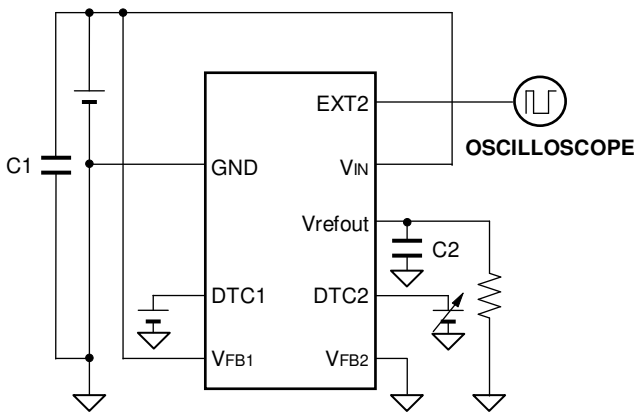

Test Circuit 9

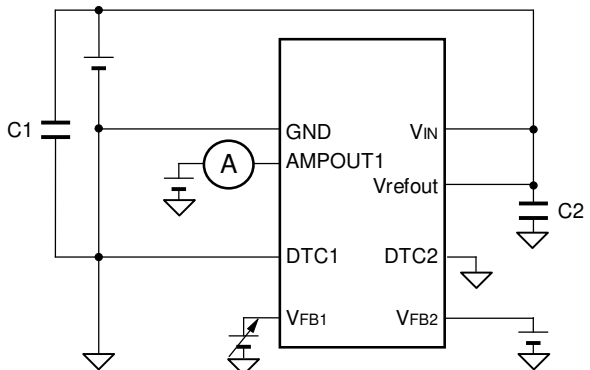

Test Circuit 10

Typical Characteristics shown in the following pages are obtained with test circuits shown above.

- Test Circuit 1,2 : Typical Characteristic 4)
- Test Circuit 3 : Typical Characteristic 5)
- Test Circuit 4 : Typical Characteristic 5)
- Test Circuit 5 : Typical Characteristic 6)
- Test Circuit 6 : Typical Characteristics 7) 8)
- Test Circuit 7 : Typical Characteristic 9)
- Test Circuit 8 : Typical Characteristic 10)
- Test Circuit 9 : Typical Characteristics 10)
- Test Circuit 10 : Typical Characteristics 11) 12)

Note) Capacitors' values of test circuits
 Capacitors: Ceramic Type:
 C1=4.7μF, C2=1.0μF

Efficiency η (%) can be calculated with the next formula:

$$\eta = (V_{OUT1} \times I_{OUT1} + V_{OUT2} \times I_{OUT2}) / (V_{IN} \times I_{IN}) \times 100$$

TYPICAL CHARACTERISTICS

1) Output Voltage vs. Output Current (Topt=25°C)

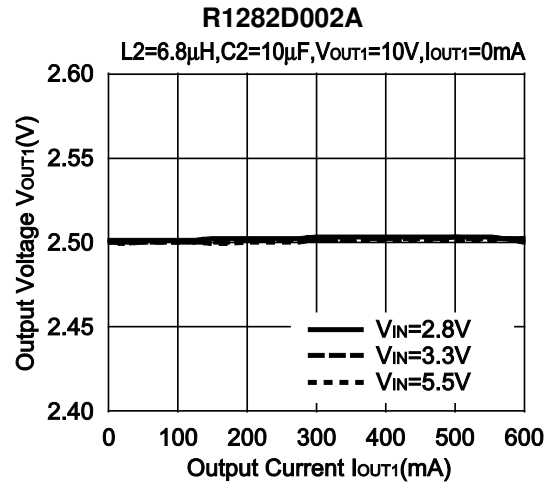
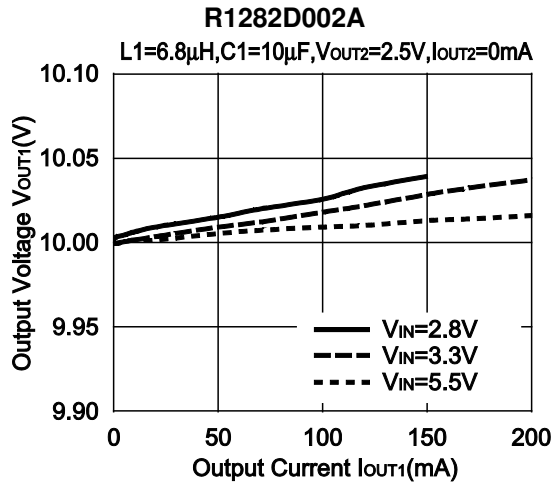

2) Efficiency vs. Output Current (VIN=3.3V, Topt=25°C)

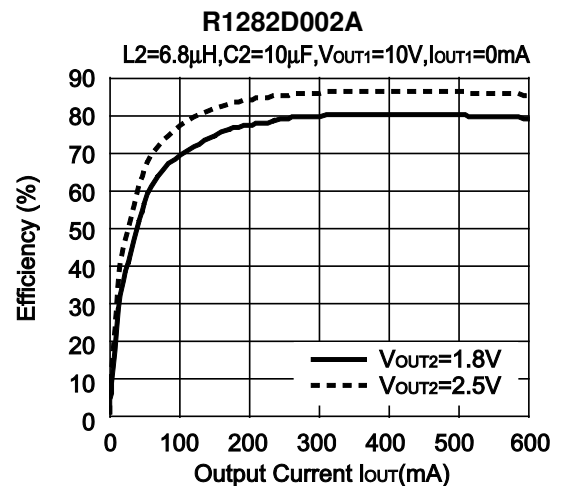
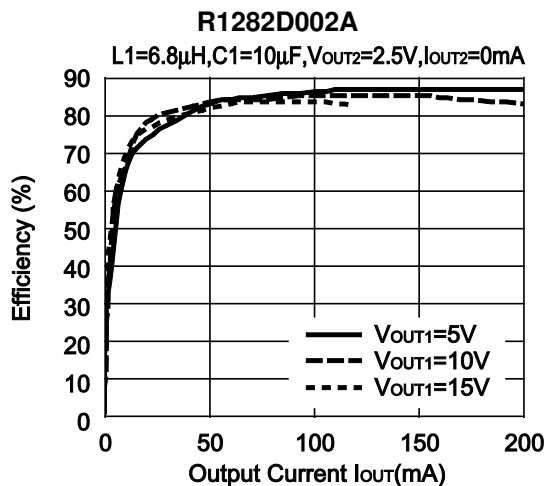

3) Output Voltage vs. Temperature (VIN=3.3V)

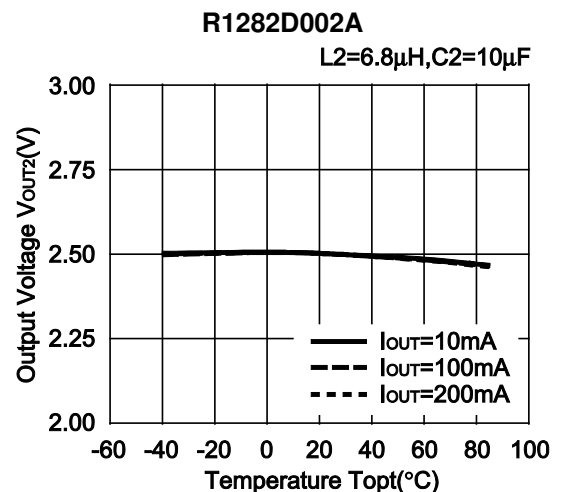
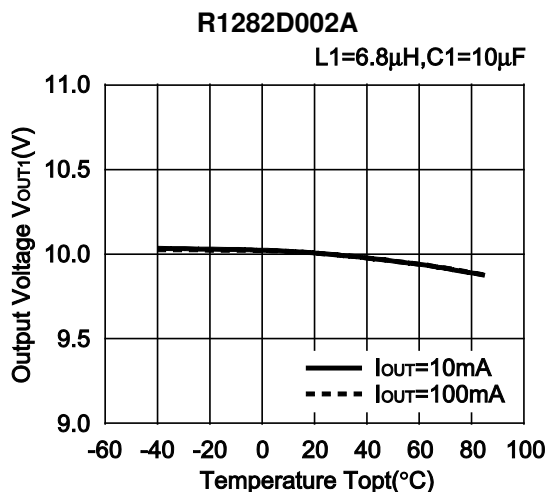

4) Frequency vs. Temperature

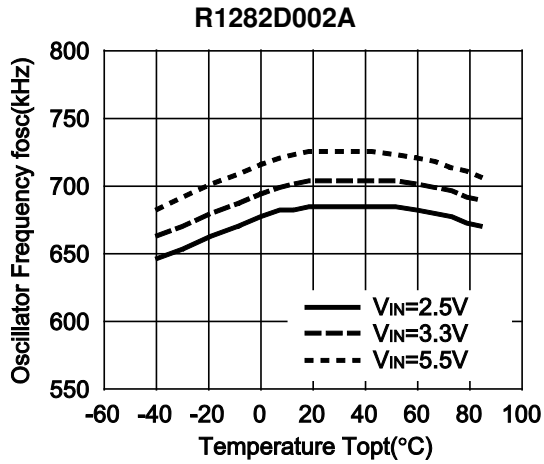

5) Feedback Voltage vs. Temperature (V_{IN}=3.3V)

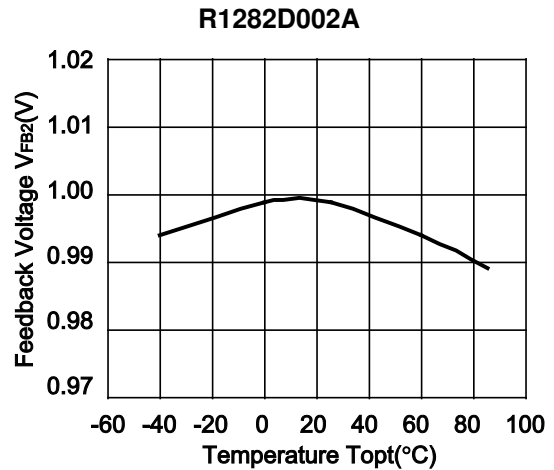
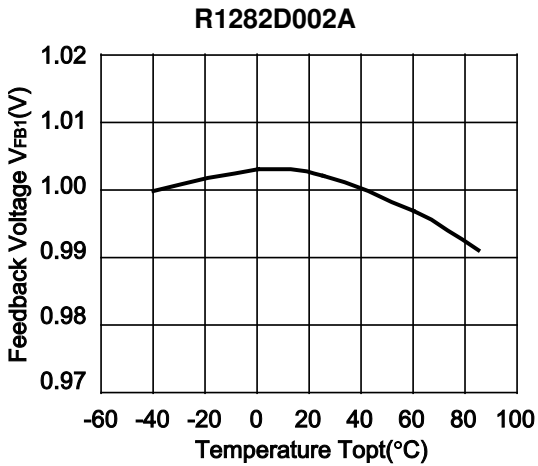

6) V_{refout} Voltage vs. Temperature (V_{IN}=3.3V)

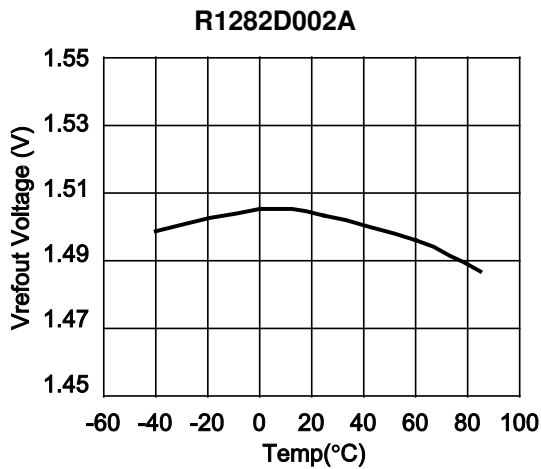

7) V_{refout} Output Voltage vs. Output Current

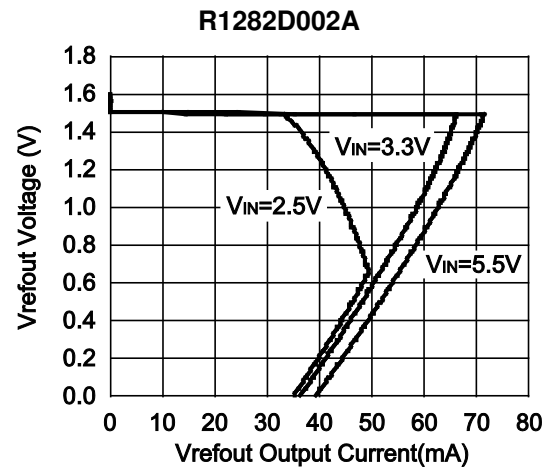

8) Vrefout Output Voltage vs. Output Current
R1282D002A

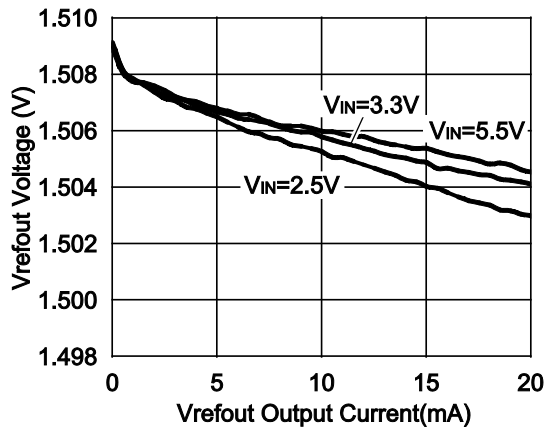

9) Protection Delay Time vs. Temperature (V_{IN}=3.3V)
R1282D002A

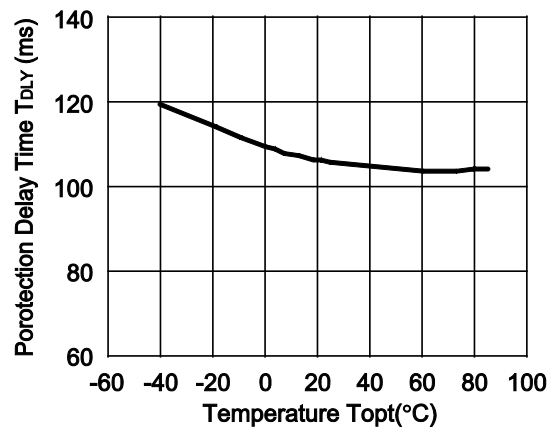

10) Maximum Duty Cycle vs. DTC Voltage (V_{IN}=3.3V)
R1282D002A

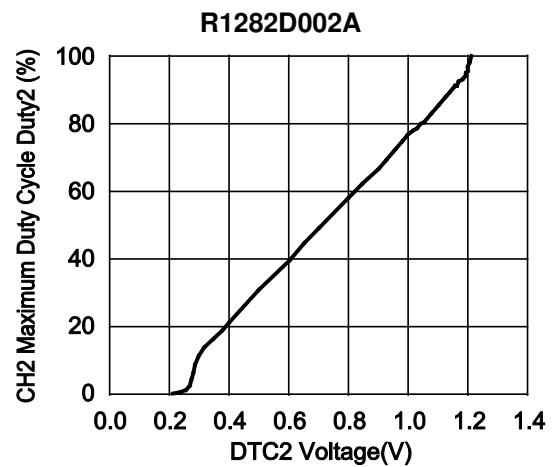
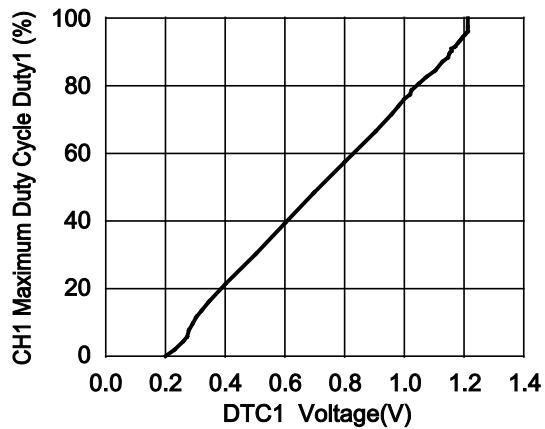

11) Output Sink Current vs. Temperature (V_{IN}=3.3V)
R1282D002A

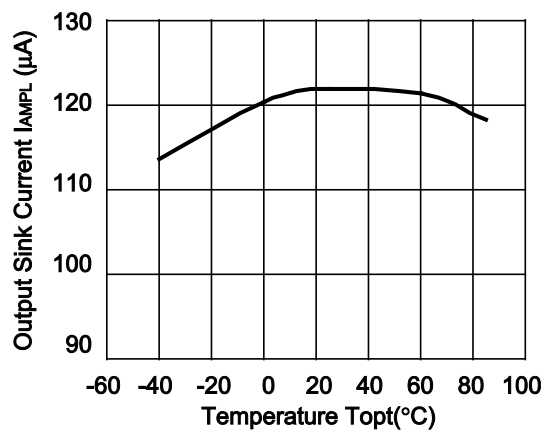

12) Output Source Current vs. Temperature
R1282D002A

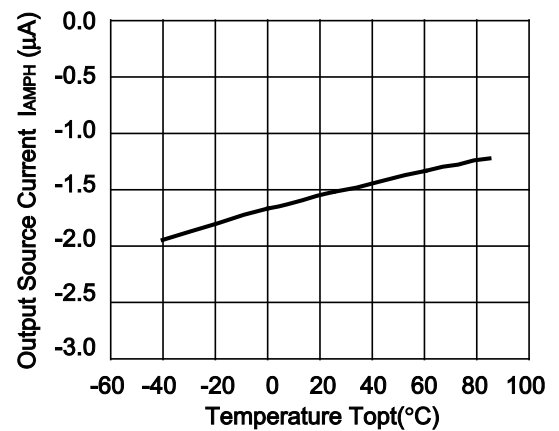

13) Load Transient Response (Step-up Side) $V_{IN}=3.3V$, $L1=6.8\mu H$

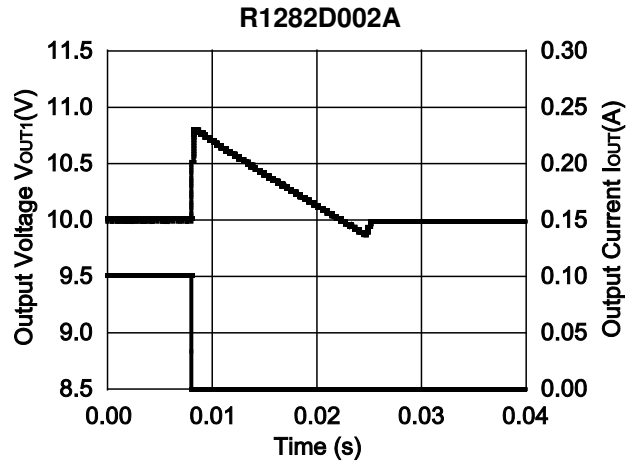
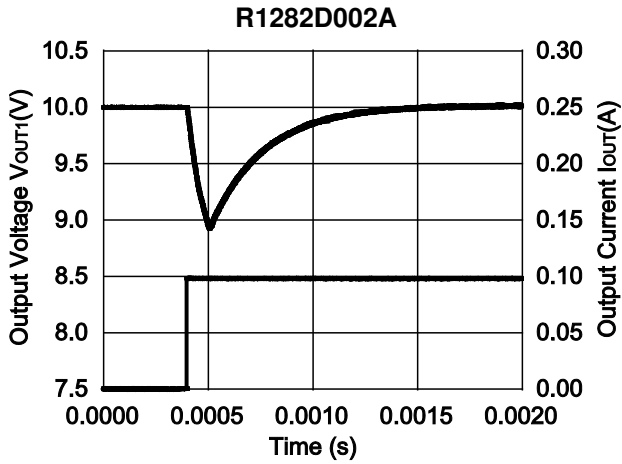

14) Load Transient Response (Step-down Side) $V_{IN}=3.3V$, $L2=6.8\mu H$

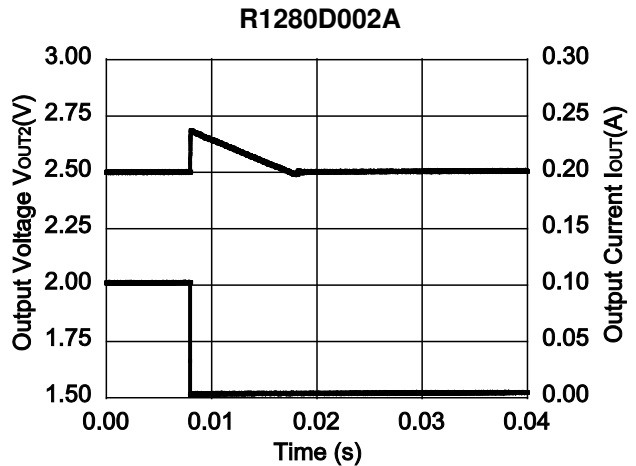
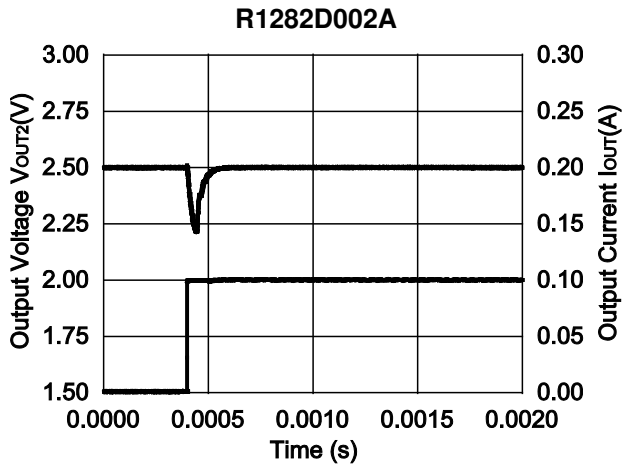

TYPICAL APPLICATION AND TECHNICAL NOTES

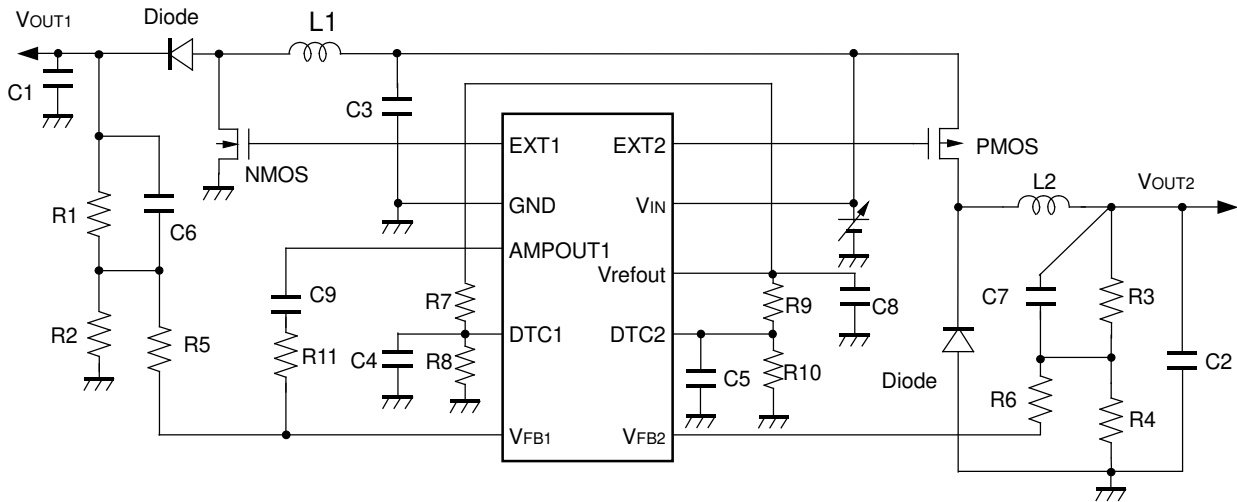

Components examples

Inductor L1,2	6.8 μ H	VLF504012MT	(TDK)
Diode	CRS10I30A	(Toshiba)	
PMOS	Si3443DV	(Siliconix)	
NMOS	IRF7601	(International Rectifier)	

Resistance As setting resistors total value for the output voltage, R1+R2, R3+R4 recommendation value is 100k Ω or less.

R1=47k Ω	R2=5.1k Ω	R3=30k Ω	R4=20k Ω
R5=43k Ω	R6=10k Ω		
R7=R9=22k Ω	R8=R10=43k Ω	R11=220k Ω	

Capacitors Ceramic Type

C1=C2=10 μ F	C3=4.7 μ F	C4=0.22 μ F	C5=0.47 μ F	C6=120pF
C7=50pF	C8=1 μ F	C9=1000pF		

Note) Consider the ratings of external components including voltage tolerance. With the transistor in the circuit above, V_{OUT}=15V is the voltage setting limit.

EXTERNAL COMPONENTS

1. How to set the output voltages

As for step-up side, feedback (V_{FB1}) pin voltage is controlled to maintain 1V, therefore,

$$V_{OUT1}: R1+R2=V_{FB1}: R2$$

Thus, $V_{OUT1}=V_{FB1}\times(R1+R2)/R2$

Output Voltage is adjustable with R1 and R2.

As for Step-down side, Feedback (V_{FB2}) pin voltage follows the next formula,

$$V_{OUT2}: R3+R4=V_{FB2} : R4$$

Thus, $V_{OUT2}=V_{FB2}\times(R3+R4)/R4$

Output Voltage is adjustable with R3 and R4.

2. How to set Soft-Start Time and Maximum Duty Cycle

Soft-start time is adjustable with connecting resistors and a capacitor to DTC pin.

Soft starting time, T_{SS1} and T_{SS2} are adjustable. Soft-start time can be set with the time constant of RC.

Soft-start time can be described as in next formula.

$$T_{SS1}\cong R01\times C4$$

If $R10=0\Omega$, then,

$$T_{SS2}\cong R9\times C5\times\ln((V_{refout}-V_{DTC2})/V_{refout})$$

Maximum Duty Cycle is set with the voltage to DTC1 and DTC2.

Maximum duty cycle is described as follows;

CH1 (Step-up side)

$Maxduty1\cong (R8/(R7+R8) \times V_{refout}-0.2)/(1.2-0.2) \times 100$ (%)

Step-up side maximum duty cycle should be set equal or less than 90%. If the maximum duty cycle is set at high percentage, operation will be unstable.

TECHNICAL NOTES on EXTERNAL COMPONENTS

- External components should be set as close to this IC as possible. Especially, wiring of the capacitor connected to V_{IN} pin should be as short as possible.
- Enforce the ground wire. Large current caused by switching operation flows through GND pin. If the impedance of ground wire is high, internal voltage level of this IC might fluctuate and operation could be unstable.
- Recommended capacitance value of C3 is equal or more than $4.7\mu\text{F}$.
- If the spike noise of V_{OUT1} is too large, the noise is feedback from V_{FB1} pin and operation might be unstable. In that case, use the resistor ranging from $10\text{k}\Omega$ to $50\text{k}\Omega$ as R5 and try to reduce the noise level. In the case of V_{OUT2} , use the resistor as much as $10\text{k}\Omega$ as R6.
- Select an inductor with low D.C. current, large permissible current, and uneasy to cause magnetic saturation. If the inductance value is too small, I_{Lx} might be beyond the absolute maximum rating at the maximum load.
- Select a Schottky diode with fast switching speed and large enough permissible current.
- Recommended capacitance value of C1 and C2 is as much as Ceramic $10\mu\text{F}$. In case that the operation with the system of DC/DC converter would be unstable, add a series resistor less than 0.5Ω to each output capacitor or use tantalum capacitors with appropriate ESR. If you choose too large ESR, ripple noise may be forced to V_{FB1} and V_{FB2} , and unstable operation may result. Use a capacitor with fully large voltage tolerance of the capacitor.
- this IC, for the test efficiency, latch release function is included. By forcing $(V_{IN}-0.3)\text{V}$ or more voltage to DTC1 pin or DTC2 pin, Latch release function works.
- Performance of the power controller with using this IC depends on external components. Each component, layout should not be beyond each absolute maximum rating such as voltage, current, and power dissipation.



1. The products and the product specifications described in this document are subject to change or discontinuation of production without notice for reasons such as improvement. Therefore, before deciding to use the products, please refer to our sales representatives for the latest information thereon.
2. The materials in this document may not be copied or otherwise reproduced in whole or in part without prior written consent of our company.
3. Please be sure to take any necessary formalities under relevant laws or regulations before exporting or otherwise taking out of your country the products or the technical information described herein.
4. The technical information described in this document shows typical characteristics of and example application circuits for the products. The release of such information is not to be construed as a warranty of or a grant of license under our company's or any third party's intellectual property rights or any other rights.
5. The products listed in this document are intended and designed for use as general electronic components in standard applications (office equipment, telecommunication equipment, measuring instruments, consumer electronic products, amusement equipment etc.). Those customers intending to use a product in an application requiring extreme quality and reliability, for example, in a highly specific application where the failure or misoperation of the product could result in human injury or death (aircraft, spacevehicle, nuclear reactor control system, traffic control system, automotive and transportation equipment, combustion equipment, safety devices, life support system etc.) should first contact us.
6. We are making our continuous effort to improve the quality and reliability of our products, but semiconductor products are likely to fail with certain probability. In order to prevent any injury to persons or damages to property resulting from such failure, customers should be careful enough to incorporate safety measures in their design, such as redundancy feature, fire containment feature and fail-safe feature. We do not assume any liability or responsibility for any loss or damage arising from misuse or inappropriate use of the products.
7. Anti-radiation design is not implemented in the products described in this document.
8. The X-ray exposure can influence functions and characteristics of the products. Confirm the product functions and characteristics in the evaluation stage.
9. WLCSP products should be used in light shielded environments. The light exposure can influence functions and characteristics of the products under operation or storage.
10. There can be variation in the marking when different AOI (Automated Optical Inspection) equipment is used. In the case of recognizing the marking characteristic with AOI, please contact our sales or our distributor before attempting to use AOI.
11. Please contact our sales representatives should you have any questions or comments concerning the products or the technical information.



Nisshinbo Micro Devices Inc.

Official website

<https://www.nisshinbo-microdevices.co.jp/en/>

Purchase information

<https://www.nisshinbo-microdevices.co.jp/en/buy/>

